



Shown with optional stand and POP label dispenser (121076, 125578)

Ishida WM-Nano

Tabletop Wrapper with Integrated Color Touchscreen Scale and Printer

Reduce operator fatigue and increase production with the world's first tabletop automatic wrapper. The WM-Nano is the ideal solution for grocers and markets with limited space needing high performance and consistent wrapping.

The generous infeed accommodates a wide range of trays, wraps up to 7.5 pound packs, and uses film 16 to 22 inches wide.

The WM-Nano employs the power and flexibility of the Ishida Uni-7 RP, with color touchscreen, integrated printer, and Wi-Fi to provide wireless data communication all wrapped up in one super tabletop wrapper.

Specifications

Packs Per Minute:

Up to 15 ppm

Wrapping Capacity:

7.5 lb x 0.005 lb or 7.5 lb x 0.01 lb

Capacity (Dual Range):

15 x 0.005 lb/30 x 0.01 lb

Wrapping Size:

Width: 5.0 to 9.0 in
Length: 5.1 to 12.0 in
Height: max 5.0 in
Tray Height: 1.8 in

Rear Display:

Not available

Tray:

PSP, PP, NET

Film Type:

PVC

Power:

200 to 240V 50/60 Hz, 15A

Print Head:

Direct thermal 2.2 in head (56 mm)

Print Speed:

3.2/ 3.9/ 4.7/ 5.9 in/sec
(80/ 100/ 120/ 150 mm/sec)

Label Size:

Width: 1.2 to 2.5 in (30 to 64 mm)
Length: 0.8 to 7.9 in (20 to 200 mm)

Film Size:

16 to 22 in (400 to 560 mm)

Noise:

75 db

Operating Temperature:

41 °F to 95 °F (5 °C to 35 °C)

Humidity:

20% to 85% relative humidity

Dimensions:

(W x L x H)
27.5 x 33.5 x 27.5 in
(700 x 850 x 700 mm)

Weight:

188 lb (85 kg)

Classification:

NTEP CC 07-099

Warranty:

One-year limited
Based on volume of 900 packs per day



Standard Features

- 7-inch color LCD touchscreen with backlight and positive input response
- Adjustable touchscreen viewing angle
- Dual-range weighing (0 to 15 lb x 0.005 lb/ 15 to 30 lb x 0.01 lb)
- Front-load label cassette
- Internal wireless communications, 802.11 b/g
- Ethernet communications
- Up to 99 pages of preset keys
- 77 tactile keys
- 4 MB standard memory expandable to 2 GB
- 30+ selectable fixed bar code formats
- Compatible with third-party communication software, including Invatron's PLUM and ADC's InterScale
- Supports 2020 nutritional data requirements

PART #	MODEL	CAPACITY
120674	WM-Nano, tabletop wrapper with integrated color touchscreen scale and printer	15 x 0.005 lb/30 x 0.01 lb

Please refer to the labels section of this catalog for ordering information and case quantity pricing.

WM-Nano Tray List with Suggested Film Sizes

Tray	Dimensions*	Suggested Film Size**	400 mm	450 mm	500 mm
2	8.3 x 5.8 x 1.0 in		√		
2S	8.3 x 5.8 x 0.5 in		√		
4S	9.3 x 7.3 x 0.5 in		√		
4D, 4H, 4P	9.3 x 7.3 x 1.1 in		√		
8S	10.3 x 8.3 x 0.5 in				√
8D, 8H, 8P	10.3 x 8.3 x 1.0 in				√
9L	12.1 x 9.3 x 0.8 in				√
10S	10.8 x 5.8 x 0.5 in		√		
11P	11.5 x 7.1 x 1.2 in				√
12S	11.3 x 9.3 x 0.5 in				√
16S	12.3 x 7.3 x 0.5 in		√		
20S	8.5 x 6.5 x 0.5 in		√		
26D	13.6 x 8.0 x 1.3 in			√	

*Trays vary by manufacturer. Verify the tray dimensions prior to selecting the film sizes for the Ishida WM-Nano.

**Suggested Film Size is based on 1 -inch product height. Higher product may require larger film. Be mindful that film stretch varies by thickness (gauge), manufacturer and room temperature.

Ishida WM-Nano

Tabletop Wrapper with Integrated Color Touchscreen Scale and Printer

PART #	MODEL/DESCRIPTION	CAPACITY	EST. SHIPPING WEIGHT	PRICE
120674	WM-Nano, tabletop wrapper with integrated color touchscreen scale and printer	0-15 x 0.005 lb/ 15-30 x 0.01 lb	250lb (L x W x H) 40 x 35 x 38in	Consult

Options/Accessories

167774	In-use cover, operator keyboard			Consult
110996	Additional label cassette			Consult
153320	Linerless label cassette			Consult
121076	Stand, stainless steel with leveling legs, 28 x 26 x 27 in (W x D x H)			Consult
125578	Day Glow label dispenser, 25-3/4 x 7-5/8 in aluminum, 20 roll capacity includes the arms that mount the Day Glow dispenser to the stand (PN 121076)			Consult
151761	Day Glow label dispenser spacer, pack of ten			Consult
121077	Plastic washdown cover, short for use with WM-Nano on optional stand			Consult
125417	Plastic washdown cover, tall for use with Day Glow label dispenser			Consult
125832	Power cord, 15A/220V sold per foot			Consult/ft
167454	10mm additional infeed (consult factory for specifications)			Consult
91870	Compact flash card, for CPU board version PK-260A			Consult
174110	SD memory card, 2 GB, for CPU board version PK-260B			Consult

Communication

160259**	ScaleLink Pro 5 software CD, license file required and purchased separately (see page 72)			Consult
152628*	ScaleLink Pro 5 license file, one license required per computer			Consult
78860	Cross cable, Ethernet CAT5, 6 ft			Consult

Manuals and Service Tools

132998 **	Additional user's manual			Consult
154792 **	Service manual			Consult
151363**	Setup manual			Consult
151315	Service key, left door			Consult
151316	Service key, right door			Consult
160906	USB flash memory, 1 GB			Consult

Label Stock

Please refer to labels section of this catalog for ordering information and case quantity pricing

Wrapping Film

181916	400mm x 1,000m (15.75in x 3,280ft) one box of two rolls		28lb	Consult
187821	450mm x 1,000m (17.72in x 3,280ft) one box of two rolls		35lb	Consult
170110	500mm x 1,000m (19.7in x 3,280ft) one box of two rolls		38lb	Consult
203761	550mm x 1,000m (21.7in x 3,280ft) one box of two rolls		42lb	Consult

*Software key is provided after online registration is completed

**Manuals and software programs can be downloaded from the distributor section of www.ricelake.com/retail.

WM-Nano Series Financial Terms and Conditions

Our financial services group reviews open account requests. Upon approval of open account terms, orders may be subject to the following payment terms: 20% down with the order

Ishida WM-Nano

DIMENSIONS			
A	27.6 in (700 mm)	E	14.4 in (365 mm)
B	34.1 in (865 mm)	F	5.9 in (150 mm)
C	25.6 in (649 mm)	G	27.7 in (703 mm)
D	22.5 in (571 mm)		

Top Down

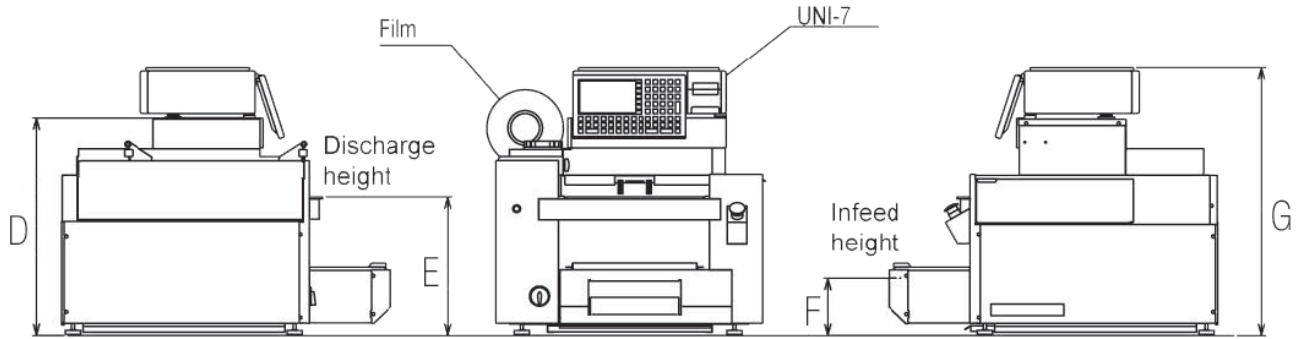
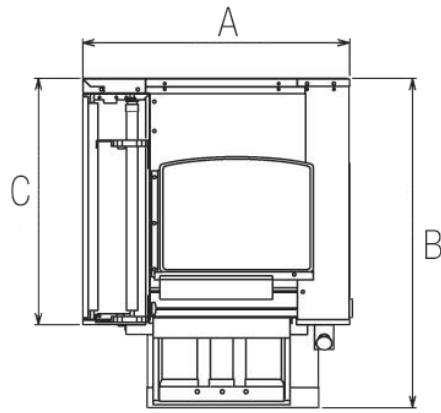

Front