

# HOME HEALTH SCALES

# RL-330HHD RL-330HHL DIAL HOME HEALTH SCALE

The RL-330HHL is a dial home health scale that displays weight in pounds while the RL-330HHD is a dial home health scale that displays weight in pounds and kilograms. The expansive steel base features a large nonslip platform and a nearly eight-inch-diameter dial. Colorful markers can be used for record and goal keeping.

RL-330HHD

## FEATURES

- Durable steel base and platform
- Nonslip mat
- Large dial display
- Units of measure: lb (RL-330HHL); lb, kg (RL-330HHD)
- Colorful markers to track weight values

## SPECIFICATIONS

### Capacity:

RL-330HHL: 330 × 1 lb (150 × 0.5 kg)

RL-330HHD: 330 × 1 lb

### Warranty:

One-year limited

RL-330HHL



## DIAL HOME HEALTH SCALE

MODEL	CAPACITY		PART #
RL-330HHD	330 × 1 lb (150 × 0.5 kg)	lb and kg	113500
RL-330HHL	330 × 1 lb	lb markings only	110592

## SHIPPING WEIGHT

MODEL #	PART #	L (IN)	W (IN)	H (IN)	PACKAGE WGT. (LB)	DIM WGT. (LB)	SHIPPING WGT. (LB)
RL-330HHD	113500	19	13	5	9	9	9
RL-330HHL	110592	19	13	5	9	9	9

## DIMENSIONS

	INCHES	CENTIMETERS		INCHES	CENTIMETERS
<b>A</b>	11.2	28.5	<b>C</b>	2.5	6.4
<b>B</b>	16.9	43.0	<b>D</b>	7.9	20.1
<b>E</b>	0.39	8.3	<i>E: (height includes plastic cover)</i>		

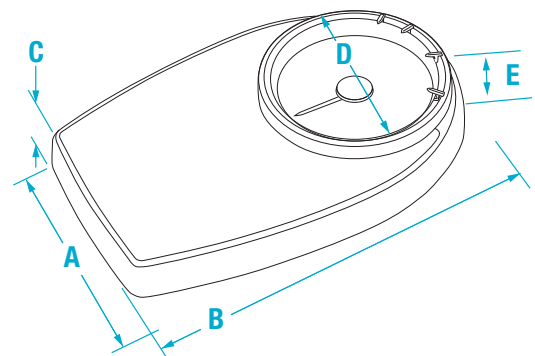

# DHH-10

## DIGITAL HOME HEALTH SCALE

Rice Lake's DHH-10 digital home health scale is designed to efficiently weigh up to 440 pounds (200 kilograms). Users can alternate between pound and kilogram weighing with a simple press of a button. Featuring a bright LCD display and tempered glass weighing surface, the DHH-10 is battery operated and indicates to users when power is low.

### FEATURES

---

- 8 mm tempered safety glass weighing surface
- Low battery indication
- Display lb or kg
- Large LCD display

### SPECIFICATIONS

---

**Capacity:**  
440 × 0.2 lb (200 × 0.1 kg)

**Dimensions:**  
(L × W × H)  
11.8 × 15.4 × 1.0 in

**Battery Type:**  
Two AAA alkaline batteries (included)

**Display:**  
Digit size: 1.75 in

**Warranty:**  
One-year limited

**Approvals:**  
CE Approved







### DIAL HOME HEALTH SCALE

MODEL	CAPACITY	PART #
DHH-10	440 x 0.2lb (200 x 0.1 kg)	201124

### SHIPPING WEIGHT

MODEL #	PART #	L (IN)	W (IN)	H (IN)	PACKAGE WGT. (LB)	DIM WGT. (LB)	SHIPPING WGT. (LB)
DHH-10	201124	17	13	2	6.5	3.0	6.5

### DIMENSIONS

	INCHES	CENTIMETERS
<b>A</b>	15.4	39.0
<b>B</b>	11.8	30.0
<b>C</b>	1.0	2.5

