

Kiosk Safety Swing-away Arm

Self Centering Kiosk Mount



Standard Features

- Protects kiosk from vehicle traffic
- Swings away freely and returns to center position
- Universal mount accommodates a wide variety of kiosks
- Includes mounting pole and base stand
- Adjustable vertical and horizontal mounting

AUTOMATED
TICKETING

Part Number/Price

Part #	Description	Price
109164	Complete kit for pit type scale (10 ft pole, red paint)	Consult
109163	Complete kit for aboveground scale (12 ft pole, red paint)	Consult
105939	Weldment, swing arm, kiosk (red)	Consult
105941	Pole weldment, 10 ft supported/free standing, 4.5 in outer dimension (red paint)	Consult
105940	Pole weldment, 12 ft supported/free standing, 4.5 in outer dimension (red paint)	Consult
110606	Weldment, swing arm 24 × 24 × 16 in side discharge printer kiosk (red paint)	Consult
155435	Weldment, swing arm 30 × 24 × 16 in side discharge printer kiosk (red paint)	Consult
178074	Complete kit for pit type scale (10 ft pole, yellow paint)	Consult
178073	Complete kit for aboveground scale (12 ft pole, yellow paint)	Consult
178077	Pole weldment, 10 ft supported free standing 4.5 in outer dimension (yellow)	Consult
178076	Pole weldment, 12 ft supported free standing 4.5 in outer dimension (yellow)	Consult
178075	Weldment, swing arm kiosk (yellow)	Consult
160403	Mount, swing arm pole for SURVIVOR ATV truck scale	Consult

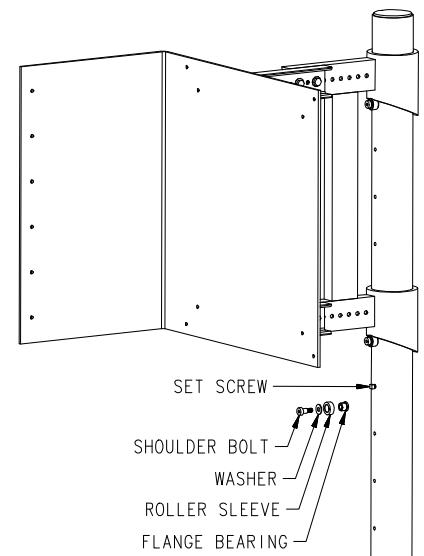
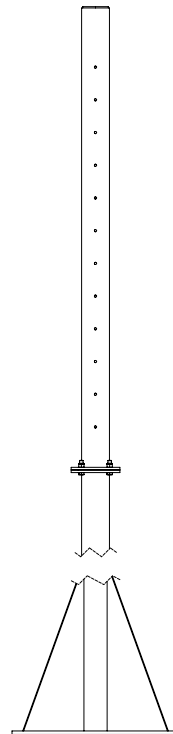
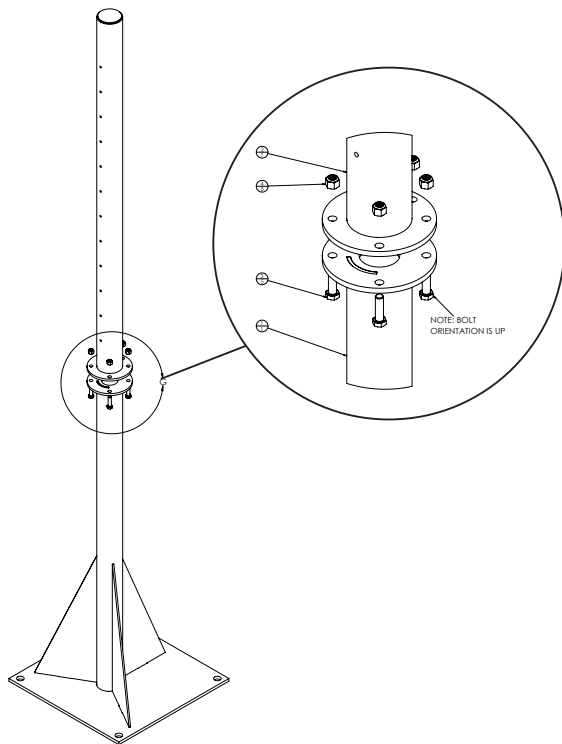

Kiosk Safety Swing-away Arm

Self Centering Kiosk Mount

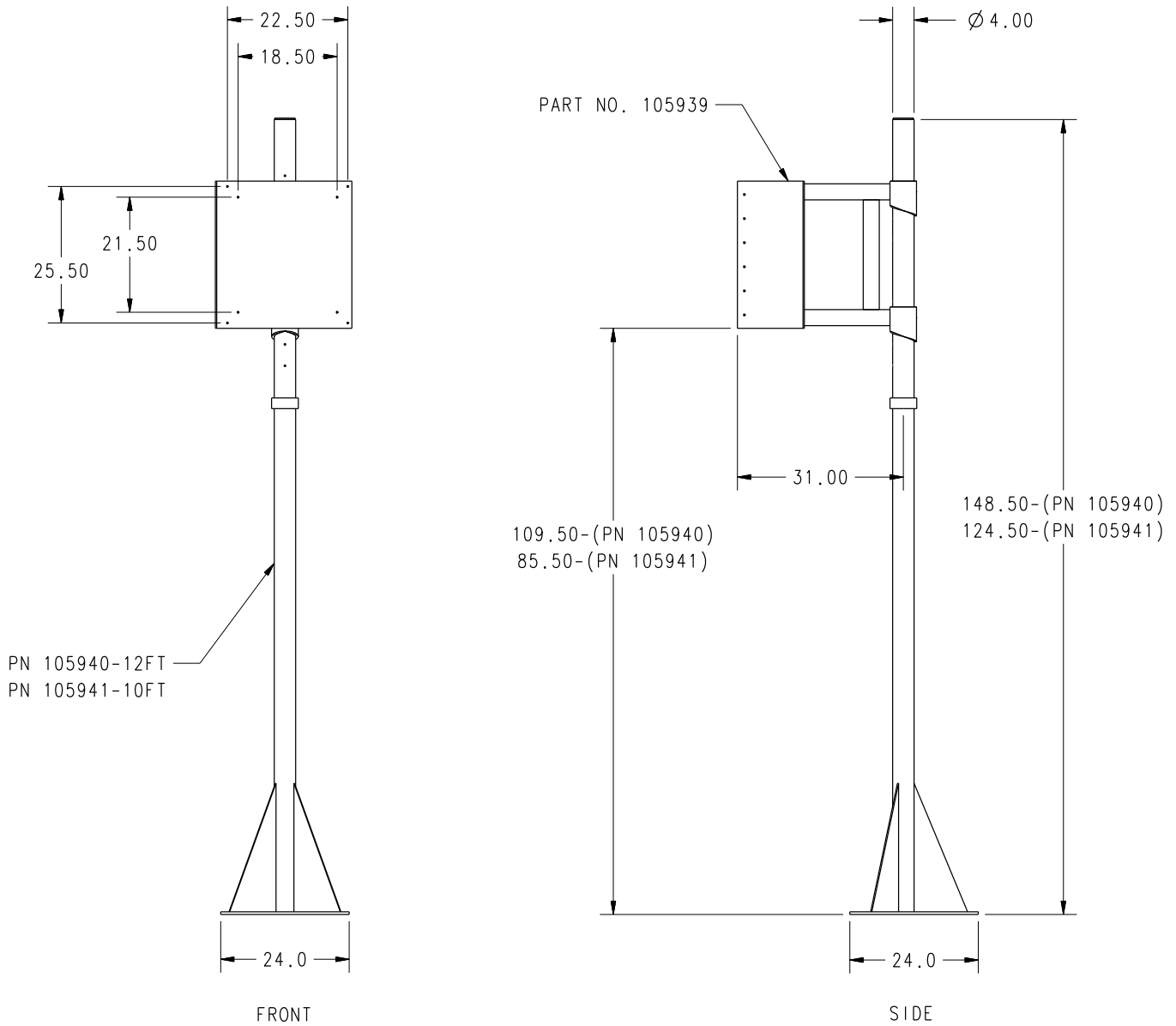

**AUTOMATED
TICKETING**

