

Confidential

Technical manual

Thermal printer unit EU-T432

Issued Date	200 , ,
Issued by	

English

4013753

EPSON

CONFIDENTIALITY AGREEMENT

BY USING THIS DOCUMENT, YOU AGREE TO ABIDE BY THE TERMS OF THIS AGREEMENT. PLEASE RETURN THIS DOCUMENT IMMEDIATELY IF YOU DO NOT AGREE TO THESE TERMS.

- This document contains confidential, proprietary information of Seiko Epson Corporation or its affiliates. You must keep such information confidential. If the user is a business entity or organization, you must limit disclosure to those of your employees, agents and contractors who have a need to know and who are also bound by obligations of confidentiality.
- On the earlier of (a) termination of your relationship with Seiko Epson, or (b) Seiko Epson's request, you must stop using the confidential information. You must then return or destroy the information, as directed by Seiko Epson.
- If a court, arbitrator, government agency or the like orders you to disclose any confidential information, you must immediately notify Seiko Epson. You agree to give Seiko Epson reasonable cooperation and assistance in the negotiation.
- You may use confidential information only for the purpose of operating or servicing the products to which the document relates, unless you obtain the prior written consent of Seiko Epson for some other use.
- Seiko Epson warrants that it has the right to disclose the confidential information. SEIKO EPSON MAKES NO OTHER WARRANTIES CONCERNING THE CONFIDENTIAL INFORMATION OR ANY OTHER INFORMATION ON THE DOCUMENT, INCLUDING (WITHOUT LIMITATION) ANY WARRANTY OF TITLE OR NON-INFRINGEMENT. Seiko Epson has no liability for loss or damage arising from or relating to your use of or reliance on the information on the document.
- You may not reproduce, store or transmit the confidential information in any form or by any means (electronic, mechanical, photocopying, recording, or otherwise) without the prior written permission of Seiko Epson.
- Your obligations under this Agreement are in addition to any other legal obligations. Seiko Epson does not waive any right under this Agreement by failing to exercise it. The laws of Japan apply to this Agreement.

Cautions

- Should any discrepancy exist between the contents of this document and the provisions of the "Master Contract" or "Specifications," the latter shall take precedence over the former.
- We shall not be responsible for any troubles that might occur from the application of this document by customer either to a machine other than this product, or to a drive circuit or other device that is the industrial property of a third party.
- No part of this document may be reproduced, stored in a retrieval system, or transmitted in any form or by any means, electronic, mechanical, photocopying, recording, or otherwise, without the prior written permission of Seiko Epson Corporation.
- The contents of this document are subject to change without notice. Please contact us for the latest information.
- While every precaution has been taken in the preparation of this document, Seiko Epson Corporation assumes no responsibility for errors or omissions.
- Neither is any liability assumed for damages resulting from the use of the information contained herein.
- Neither Seiko Epson Corporation nor its affiliates shall be liable to the purchaser of this product or third parties for damages, losses, costs, or expenses incurred by the purchases or third parties as a result of: accident, misuse, or abuse of this product or unauthorized modifications, repairs, or alterations to this product, or (excluding the U. S.) failure to strictly comply with Seiko Epson Corporation's operating and maintenance instructions.
- Seiko Epson Corporation shall not be liable against any damages or problems arising from the use of any options or any consumable products other than those designated as Original EPSON Products or EPSON Approved Products by Seiko Epson Corporation.

Trademarks

EPSON® is a registered trademark of Seiko Epson Corporation.

General Notice: Other product and company names used herein are for identification purposes only and may be trademarks of their respective companies.

Points That Must Be Observed To Assure Product Safety

To assure the safe operation of this product, carefully observe the specifications as well as the notes provided below.

Seiko Epson Corporation will not bear any responsibility for any damage or injuries arising from use of this product that is not in accordance with the specifications and the notes provided below.

Notes on Head Control

- ❑ The conditions setting forth the maximum time power can be applied (and the maximum voltage that can be applied) to electronic components such as the head, motor, and magnets must be observed.

If the maximum time power can be applied (or the maximum voltage that can be applied) is exceeded, the components mentioned above could overheat and start a fire or begin to smoke.

- ❑ Always include protective circuitry governing the length of time power is applied and the amount of current that is applied when designing the drive and control circuits for the head, motor, magnets, etc.

If protective circuitry is not included, misoperation of the printer control circuits could cause the components mentioned above to overheat and begin to smoke or burn.

Notes on Handling

- ❑ The case must be designed so that movable parts, such as gears, are not exposed.

Touching moving parts could cause a laceration or other injury.

About This Manual

This manual consists of the following chapters.

Chapter 1 Features and Specifications	This chapter contains features and general specifications for the EU-T432.
Chapter 2 Operation Principle	This chapter contains the outline and principles of mechanisms.
Chapter 3 Handling	This chapter contains precautions on handling, paper loading and unloading and removing jammed paper.
Chapter 4 Maintenance	This chapter contains information on cleaning, inspection, lubrication, and tools.
Chapter 5 Repair	This chapter contains repair levels, repair procedures, and troubleshooting.
Chapter 6 Assembly and Disassembly	This chapter contains assembly and disassembly for the units and modules of the EU-T432.
Appendix	The appendix contains the exploded and adhesive diagrams of the EU-T432.

Symbols

Notes in this manual are identified by their level of importance, as defined below.



CAUTION:

Observe cautions to avoid minor injury to yourself, damage to your equipment, or loss of data.



Note:

Notes have important information and useful tips on the operation of your equipment.

Contents

About This Manual v
Symbols v

Chapter 1 Features and Specifications

Features 1-1
System Configuration and Module Names 1-2
Specifications 1-3
 Module Combinations and Specifications: 1-4

Chapter 2 Operation Principles

Outline of Mechanism 2-1
Paper Roll Supply Module 2-1
 Paper Holding Section 2-2
 Paper Load-absorbing Mechanism 2-2
 Paper NE Detector 2-2
Printer Module 2-3
 Drive Force Transmission Mechanism 2-3
 Paper Feed Mechanism 2-4
 Printing Mechanism 2-6
 Paper Guide Mechanism 2-8
 Detector Mechanism 2-8
 Autocutter Mechanism 2-11
Cut Sheet Presenter Module 2-15
 Paper Carrying Operation (With a Loop) 2-15
 Paper Carrying Operation (Without a Loop) 2-17
 Detector Mechanism 2-17
Control Circuit Board Module 2-18
 DIP Switches 2-18
 Memory Switches 2-20

Chapter 3 Handling

Precautions 3-1
 Transport Precautions 3-1
 Carrying Precautions 3-1
 Installation Precautions 3-2
 Handling Precautions 3-2
 Storage Precautions 3-4
Opening and Closing Modules, Unit and Part 3-4
 Paper Roll Supply Module 3-4
 Platen Unit 3-4
 Cut Sheet Presenter Module 3-5
 Paper guide, upper 3-5
Loading and Removing Paper roll 3-6
 Loading a Paper roll 3-6
 Removing Paper 3-9
Removing Jammed Paper 3-9
 Removing Jammed Paper From the Cut Sheet Presenter Module 3-9
 Removing Jammed Paper From the Printer Module 3-10
Paper NE Detector Setting 3-10
Self Test 3-12
 Performing the Self Test 3-12
 Self Test End 3-12
Errors 3-13

LED Display	3-13
POWER LED (Power Supply Error): Green	3-13
PAPER LED (Paper-End Error): Red	3-13
ERROR LED (Error): Red	3-13

Chapter 4 Maintenance

Cleaning	4-1
Thermal Head Cleaning	4-1
Removing Stains (Except for the Thermal Head)	4-2
Removing Dirt and Dust	4-2
Removing Foreign Matter When the Cutter Locks	4-2
Inspection	4-3
Daily Checks	4-3
Periodic Checks	4-3
Lubrication	4-4
Lubricant	4-4
Lubrication Standards	4-4
Lubrication Point	4-4
Lubricant List	4-5
Tools	4-5

Chapter 5 Repair

Repair Levels	5-1
Repair Procedure	5-1
Troubleshooting	5-2

Chapter 6 Assembly and Disassembly

Small Parts Abbreviation	6-1
Disassembly	6-2
Assembly	6-2
Installation of the Printer Module	6-3
Pre-assembly A: Paper guide, straight, back unit	6-3
Pre-assembly B: Frame, platen, straight unit, B	6-4
Pre-assembly C: Cutter motor assembly	6-7
Pre-assembly D: Cutter, cover sub-unit	6-8
Pre-assembly E: Cutter unit, B	6-11
Pre-assembly F: Black mark detector sub-assembly (option)	6-13
Main Assembly A: Motor, paper feed, receipt, B and Platen detector ..	6-14
Main Assembly B: Paper guide, straight, front and Paper guide, straight, back unit	6-16
Main Assembly C: Frame, platen, straight unit	6-18
Main Assembly D: Thermal print head assembly	6-20
Main Assembly E: Plate, pressure spring	6-21
Main Assembly F: Fixing plate, the Gear, reduction and Gear, idler ..	6-23
Main Assembly G: Cutter unit	6-24
Assembly H: Arranging the lead wires	6-25
Main Assembly I: Cable, printer and Cable, head	6-26
Assembly J: Black mark detector Adjustment	6-27
Main Assembly K: Cover, cable	6-28
Main Assembly L: Cover, gear	6-29

Installation of the Other Modules 6-30

- Pre-assembly A: Frame, paper supply assembly 6-30
- Pre-assembly B: Roll paper holder unit 6-34
- Pre-assembly C: Roll paper supply module 6-39
- Pre-assembly D: Presenter table assembly 6-40
- Pre-assembly E: Presenter frame, right assembly 6-41
- Pre-assembly F: Presenter frame, left assembly 6-42
- Pre-assembly G: Paper guide assembly 6-43
- Pre-assembly H: Cutting sheet presenter module 6-44
- Main Assembly A: Printer module 6-49
- Main Assembly B: Cut sheet presenter module 6-52
- Main Assembly C: Roll paper supply module 6-53
- Main Assembly D: Control circuit board and Cover, circuit boards
upper/ lower 6-54
- Main Assembly E: Roll paper shaft assembly 6-57

Appendix

EU-T432 Exploded Diagram 1

Printer Module Exploded Diagram 2

Cut Sheet Presenter Module Exploded Diagram 3

Roll Paper Supply Module Exploded Diagram 4

EU-T432 Lubrication Diagram 5

Printer Module Lubrication Diagram 6

Cut Sheet Presenter Module Lubrication Diagram 7

Roll Paper Supply Module Adhesive Diagram 8

Chapter 1

Features and Specifications

Features

The EU-T432 is designed to be used for kiosks and cash dispensers. The features of the EU-T432 are as follows:

- ❑ High speed receipt issuing: 150 mm/s {5.9"/s} maximum
- ❑ High reliability: 300,000 receipt issue
- ❑ Length of receipt: 228.4 mm {9"} maximum
(When the EU-T432 is equipped with an optional loop guide: 600 mm {23.6"})
- ❑ Available for large paper roll core dimensions:
203 mm {8"} diameter maximum
- ❑ Supports ESC/POS[®] equivalent commands
- ❑ Able to print bar codes (fence and ladder) and graphics
- ❑ Options available for all models:
 - Japanese Kanji model: Supports JIS Level 1 and 2
 - Simple Chinese model: Supports GB50007-85
 - Traditional Chinese model: Supports BIG5 Level 1 and 2
 - Korean model: Supports C-6501C
- ❑ Driver and status monitor are available.

System Configuration and Module Names

The whole systems is called the “EU-T432.” The EU-T432 consists of four modules and the configuration of the modules are shown below:

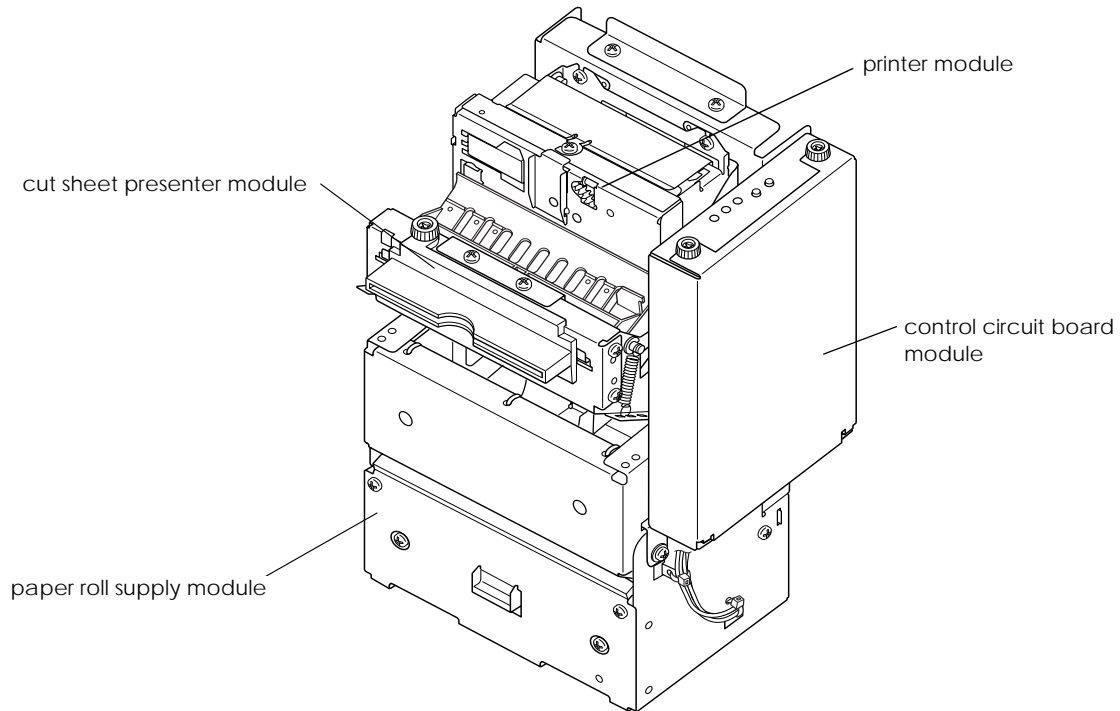

Figure 1-1 EU-T432 appearance

Specifications

The basic specifications of the EU-T432 are shown below. Refer to the specifications for the EU-T432 issued by Seiko Epson Corporation for more details.

Table 1.1 Specifications

Item		Specification
Paper roll	Outside diameter	152.4 mm {6"} (When equipped with an optional part: 203 mm {8"})
	Paper width	79.5 ± 0.5 mm {3.13 ± 0.02"}
Paper carrying speed		150 mm/s {5.9"/s} maximum
Paper length to be presented	Issuing the cut sheet (Receipt printing)	When the cut sheet is looped: 76.2 to 228.6 mm {3 to 9"} When equipped with an optional loop guide: 76.2 to 600 mm {3 to 23.6"} When the cut sheet is not looped: 76.2 to 3000 mm {3 to 118.1"}
Print speed		150 mm/s {5.9"/s} maximum
Print width		72 mm {2.84"} maximum (recommended)
Reliability	Receipt printing	300,000 times
	Printer	Mechanism: 15,000,000 lines Thermal head: 100 km {62.14 miles}, 100 million pulses
Paper roll	Specified thermal paper	Original paper No.: P350 KSP Original paper No.: TF50KS-E NIPPON PAPER INDUSTRIES CO.,LTD Original paper No.: PD160R OJI PAPER MFG.CO., LTD Original paper No.: TF11KS-ET NIPPON PAPER INDUSTRIES CO.,LTD Original paper No.: TF51KS-X1 NIPPON PAPER INDUSTRIES CO.,LTD Original paper No.: PD200N OJI PAPER MFG.CO., LTD Original paper No.: AFP234 MITSUBISHI PAPER MILLS CO., LTD A different paper type may give a different print quality.
	Paper thickness	60 to 150 μm If the paper thickness is more than 120 μm, the paper loop must not be used.

Table 1.1 Specifications

Item		Specification
Environmental condition	Operating temperature	0 to 50°C
	Operating humidity	10 to 80% RH

Print quality is guaranteed.

Operation is guaranteed.

Module Combinations and Specifications:

Table 1-2 Module Combinations and Specifications

Item		6 inch type	8 inch type
Combination of each module	Paper roll module	Yes	Yes
	Printer module	Yes	Yes
	Control board module	Yes	Yes
	Cut sheet presenter module	Yes	Yes
	Paper supply spacer	—	Yes
Mass		Approximately 3.8 kg {8.38 lb}	Approximately 3.9 kg {8.60 lb}
External dimensions (W × D × H): mm		194.7 × 170.6 × 300 {7.7 × 6.7 × 11.8"}	194.7 × 170.6 × 350 {7.7 × 6.7 × 13.8"}

Chapter 2

Operation Principles

Outline of Mechanism

The EU-T432 consists of four modules: the paper roll supply module, the printer module, the cut sheet presenter module, and the control circuit board module.

Paper Roll Supply Module

The paper roll supply module holds a large diameter paper roll and guides the paper to the printer module. This module consists of the paper holding part, the paper load-absorbing mechanism, and the paper near-end detector. The appearance of this module is shown below.

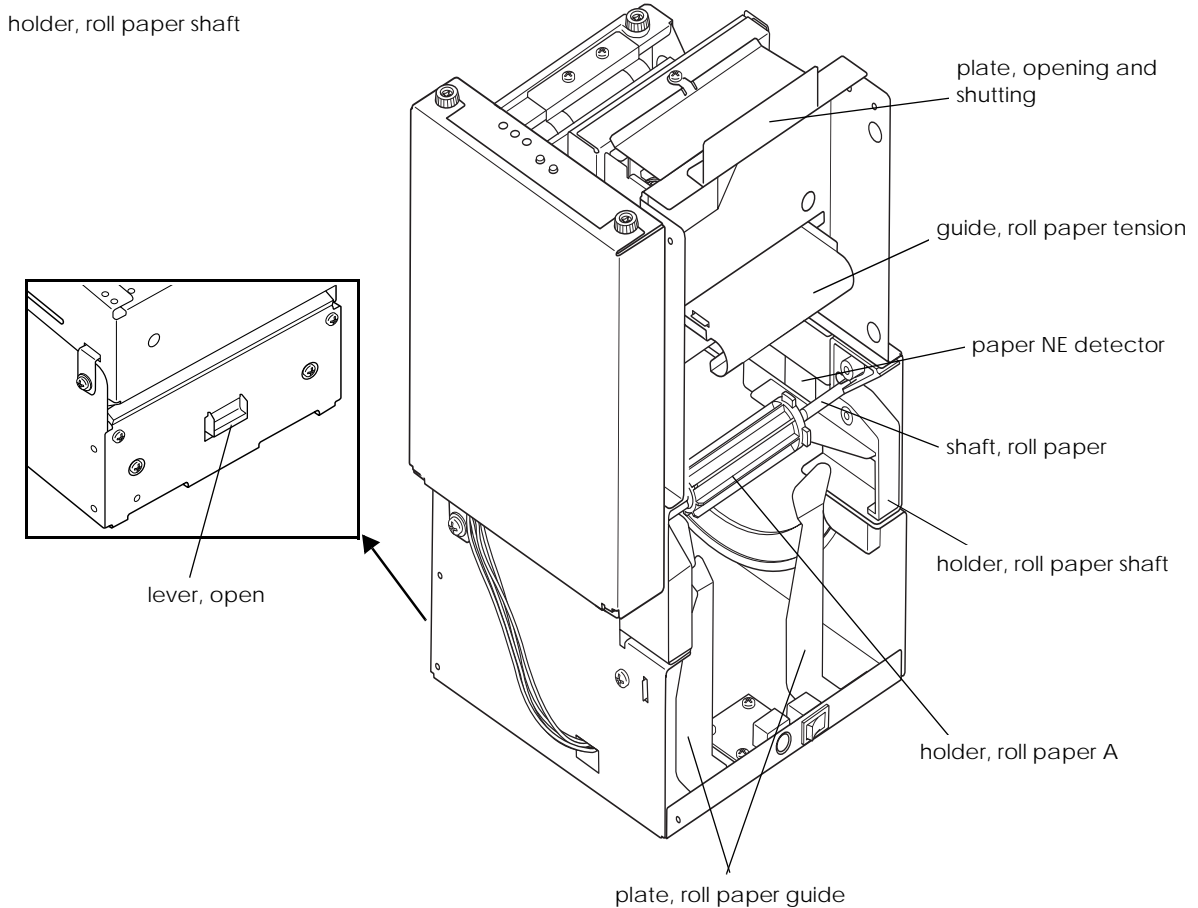

Figure 2-1 Paper roll supply module appearance

Paper Holding Section

The paper roll holding mechanism is a shaft support type. The paper roll holding section consists of the removable **shaft, roll paper**, the **holder, roll paper A** (for the inner diameter of the paper core: 25.4 mm {1 inch}) that fits the size of the paper roll core used, the **holder, roll paper shaft** that supports the **shaft, roll paper** and the **plate, roll paper guide** that holds the sides of the paper roll.

The paper holding section turns on a fixed screw section so that the paper holding section can be opened and closed. The paper holding section can be opened by pulling down the **plate, opening and shutting** while holding down the **lever, open**. When closing the paper holding section, pull up the **plate, opening and shutting** causing the **lever, open** to be locked automatically; then the paper holding section is closed securely.



Note:

*If the paper inner core dimension differs from the **holder, roll paper A** due to the paper thickness, you can replace it with an optional holder, a **holder, roll paper B** (for the inner diameter of the paper core: 50.8 mm {2 inch}) or a **holder, paper roll C** (for the inner diameter of the paper core: 76.2 mm {3 inch}).*

Paper Load-absorbing Mechanism

The paper load-absorbing mechanism consists of the **guide, roll paper tension** that receives the paper tension. Using the paper tensile force generated when feeding the paper, this mechanism oscillates the **guide, roll paper tension** and reduces the paper feeding load due to inertia of the paper roll.

Paper NE Detector

The **paper NE detector** has two kind of detections, the primary NE detection and the secondary NE detection. The primary NE detection can detect the amount remaining on the paper roll using a reflecting photo sensor. After the primary NE detection, the secondary detection can be used to return the status when the paper is fed to the length specified by the memory switch setting. (See SW No. 2, 3 in Table 2-10 on page 2-20.)

The **paper NE detector** is mounted on the **frame** and is secured with a screw. The position of the **paper NE detector** can be altered to adjust the setting for the amount remaining on the paper roll.

Printer Module

The printer module has a printing mechanism with the paper feeding and a cutting mechanism to cut the paper.

The printer consists of the following six mechanisms: the drive force transmission mechanism, the paper feed mechanism, the printing mechanism, the paper guide mechanism, the detector mechanism, and the autocutter mechanism.

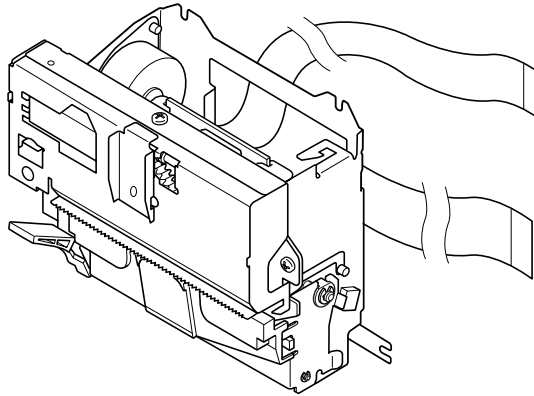

Figure 2-2 Printer module appearance

Drive Force Transmission Mechanism

This mechanism consists of the motor, paper feed, receipt, B (fixed to pinion), the gear, reduction, the gear, idler, and the gear, platen. The printer uses a stepping motor, the rotation force of which is reduced in sequence by the gear, reduction and the gear, idler before being transmitted to the gear, platen. (The arrows in the figure below indicate the direction of the gear rotation.) The gear, platen is mounted to the frame platen unit and separates from the gear, idler when the platen is open.

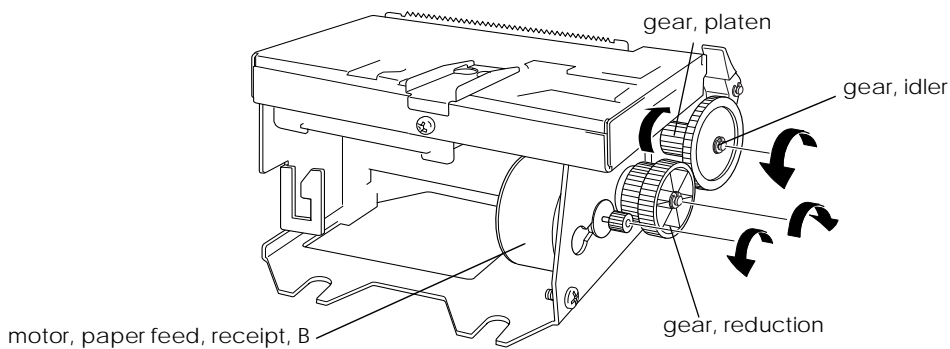

Figure 2-3 Drive force transmission mechanism

This printer uses a 4-phase bi-polar stepping motor driven by 24 V voltage controlled 2-2 phase excitation. The maximum drive frequency of 2-2 phase excitation is 1200 pps. [pps: pulses per second]

Paper Feed Mechanism

This mechanism consists of the paper feed mechanism and the platen-open mechanism.

Paper feed mechanism

The paper feed mechanism consists of the **platen** (paper feed roller) and the **thermal head**. When the **motor, paper feed, receipt, B** rotates counterclockwise as viewed from the shaft, the gear train transmits the motion to the **platen** which rotates in direction **A**.

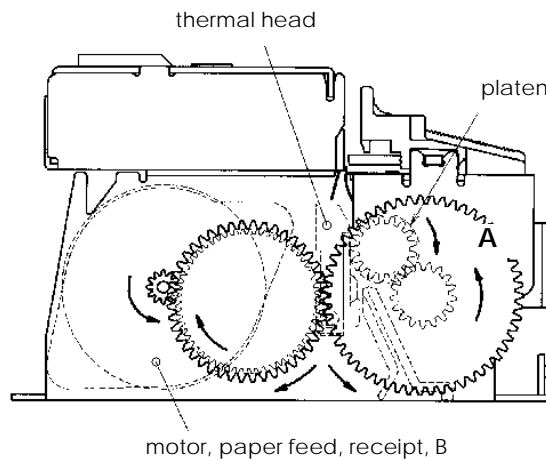

Figure 2-4 Paper feed mechanism

Paper feed operation during printing

The **platen** presses the thermal paper against the **thermal head** with a constant force. When the **platen** rotates in direction **A**, the thermal paper advances in direction **B**.

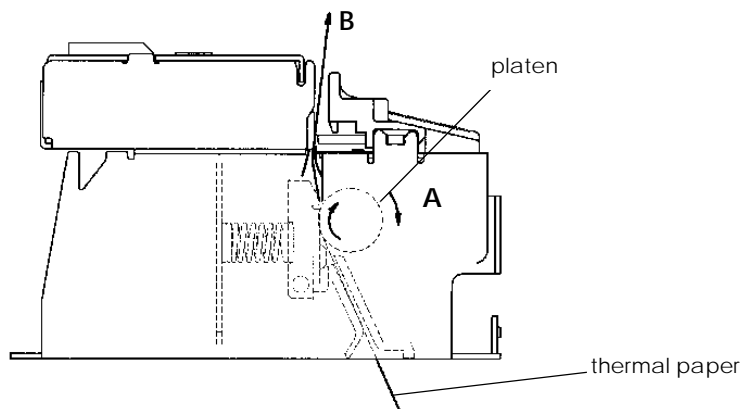

Figure 2-5 Paper feed operation during printing

Platen-open mechanism

The platen-open mechanism is used for the following purposes:

- Paper loading when using the printer with the curved path type. (Excluding when using semi-autoloading mode.)
- Removing a paper jam when the paper jam has occurred
- The thermal head and the platen cleaning

The mechanism consists of the frame, platen, the lever, platen, the shaft, platen, the spring, lever, the lock lever, the spring, lock lever, and the pushplate, platen, B.

In the frame, platen, the platen is mounted. The lever, platen is operated by hand to open the frame platen unit. The shaft, platen connects the lever, platen and the frame, platen to the frame, base in a manner which allows them to rotate. The spring, lever pulls the lever, platen in the opposite direction of arrow A when the platen is open. The lock lever is located on the gear train side of the frame, platen and locks the frame platen unit to the frame, base. The spring, lock lever (inside the lock lever) pushes the lock lever back. The pushplate, platen, B is secured on top of the frame, platen and covers the fixed blade.

When the frame platen unit is closed, the platen is in the print-ready position where the gear, platen and the gear, idler are engaged and the power can be transmitted readily. Also, the lock lever is locked at a part of the frame, base to prevent the gears from disengaging.

To open the platen, turn the lever, platen in the direction of arrow A as shown in Figure 2-6. Simultaneously, the lock lever is released and the frame platen unit is opened. To close the platen, turn the lever, platen in the opposite direction of arrow A until the lever stops.

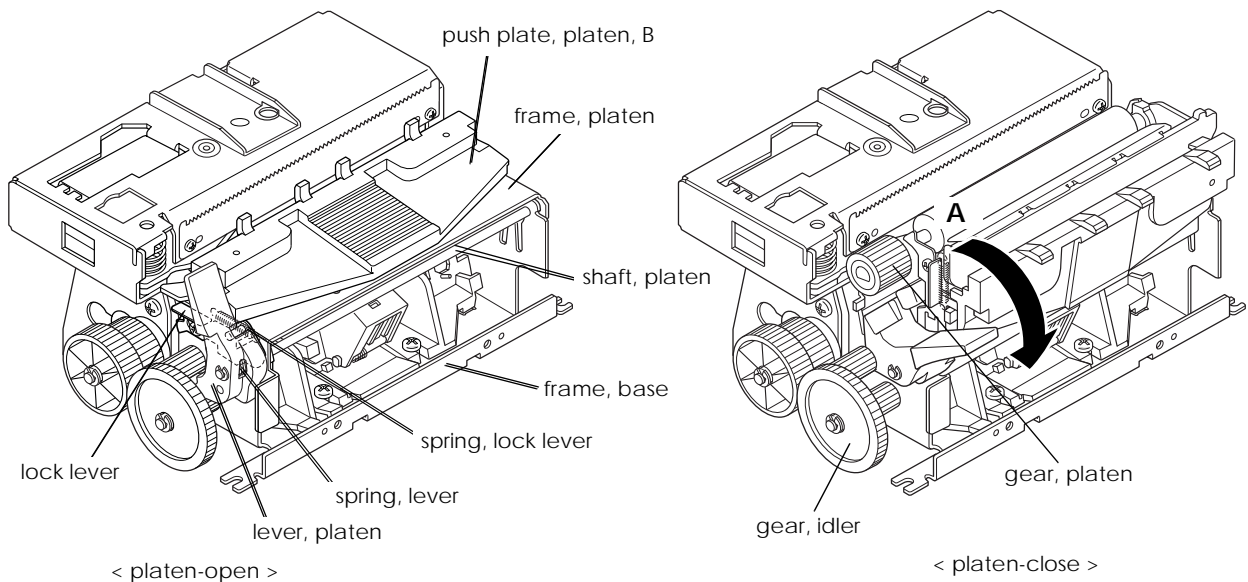

*The cover, gear is removed in these figures.

Figure 2-6 Platen-open mechanism

Printing Mechanism

This mechanism consists of the **thermal head** which has the head heating elements arranged in a series and has a driver IC for controlling voltage to the head heating elements, the **platen** which is also used for the paper feed mechanism as well as this mechanism (the **thermal head** is also used for both mechanisms), and the **spring, press head**. The **platen** presses the thermal paper wrapped around the **platen** against the head heating elements pressed by the **spring, press head**. When the elements are activated, the paper is heated at the designated points, resulting in the printing action.

Printing operation principles

The cross-sections of the **thermal head** and the thermal paper are shown below. Printing is performed in the following steps:

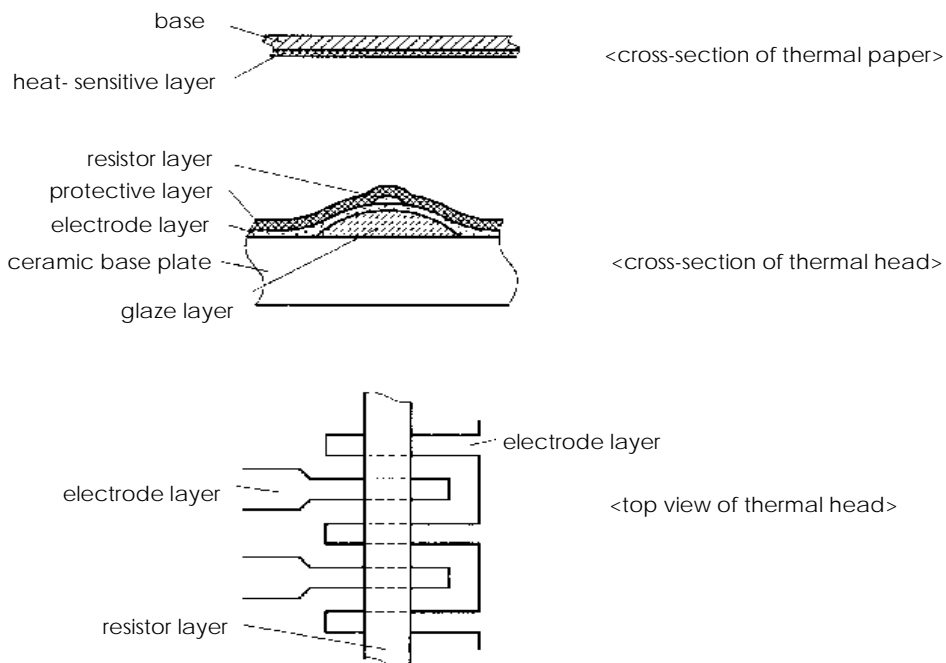

Figure 2-7 Cross-section of thermal head and thermal paper

1. Drive pulses are sent to the designated dot electrodes in accordance with the print signal.
2. Since the resistor layers are formed at the top of each electrode inside of the **thermal head**, the resistor layers are heated up when the drive pulses are sent to the electrodes.
3. The thermal energy of the heated resistors is transferred via the protective layer of the **thermal head** to the surface of the thermal paper, and the heat-sensitive layer of the paper changes color, thus forming the printed character.

Data input and printing

The thermal head consists of the head heating elements, the head driver, which controls or drives the head heating elements, and the thermistor, which detects the temperature of the thermal head. The serial print data input from Data In (DI1) is synchronized to the CLOCK (CLK) input, and temporarily placed in the SHIFT REGISTER. Using the LATCH (/LAT) signal timing, these data are then stored in the LATCH REGISTER. Activated by the STROBE signals (/STR1, /STR2), the stored print data is used to control the gate ON condition for the head heating element drive pulse.

This printer is equipped with two strobes, and can print using a maximum of four divisions. The drive pulse width is controlled by the control circuit board module.

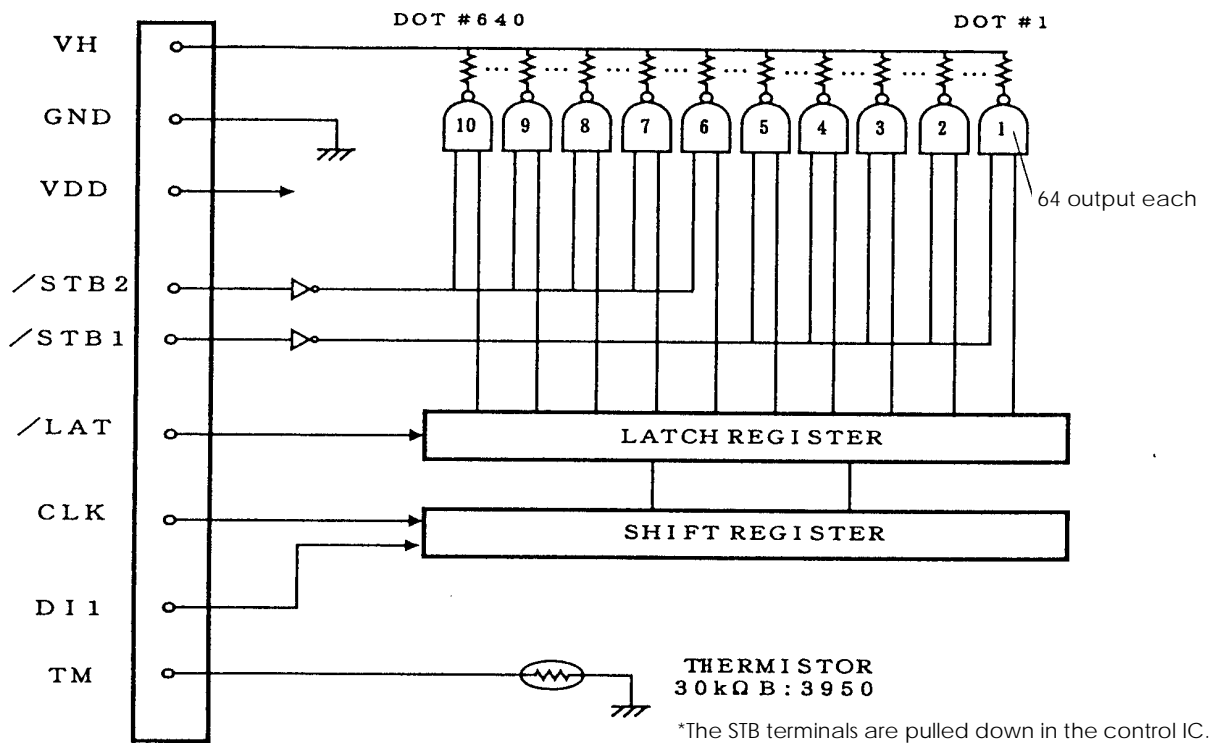

Figure 2-8 Thermal head block diagram

Table 2-3 Strobe and Dot Number

STROBE No.	Dot No.	Dots/STROBE
1	1 to 320	320
2	321 to 640	320

Paper Guide Mechanism

This mechanism consists of the paper guide mechanism. The paper path consists of the paper guide, straight, front and the paper guide, straight, back. The paper path is shown below.

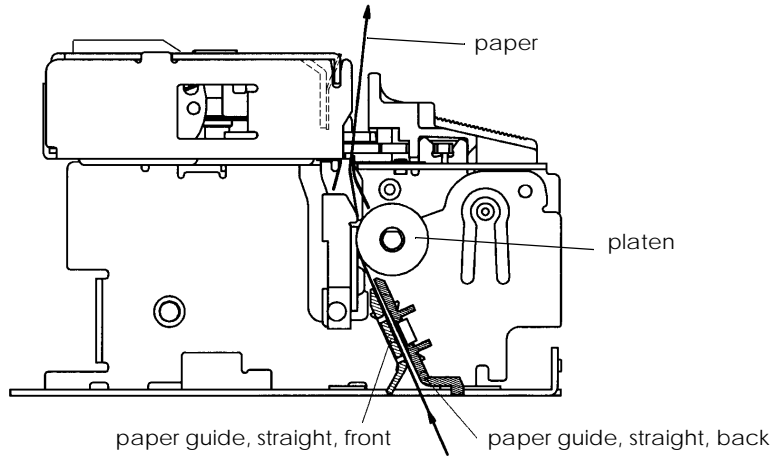

Figure 2-9 Paper path

Detector Mechanism

This mechanism consists of the paper-end mechanism, the platen-open detector mechanism, the head temperature detector mechanism, and the black mark detector mechanism.

Paper-end detector mechanism

The paper-end detector mechanism is located inside the paper guide mechanism to detect the end of the thermal paper and the paper insertion state in the semi-autoloading mode. This mechanism consists of the transparent photo sensor, the lever, paper detector which presses against the thermal paper and the spring, paper detector which pulls the lever, paper detector.

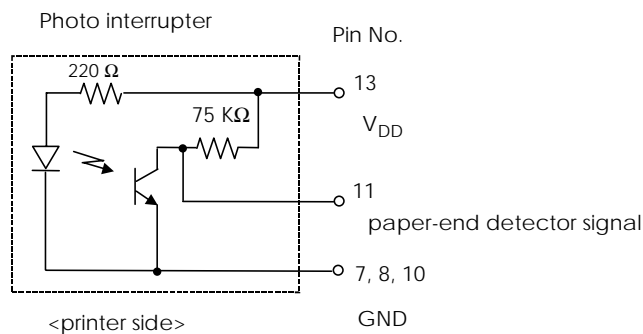

Figure 2-10 Paper -end detector circuit

The transparent photo sensor is in a high state (HI) when the paper is present, and in a low state (LOW) when the paper is not present because the lever, paper detector blocks light to the sensor. When the end of the thermal paper passes through the paper guide, the lever, paper detector operates as shown in Figure 2-11. At this time, the output level from the transparent photo sensor varies as shown in Figure 2-12, then the absence of paper is detected. When the semi-autoloading function is used, the insertion of paper changes the status from “no paper” to “paper.” Since the output level changes from LOW to HI, the status changes to “paper”; then the semi-autoloading function is initiated.

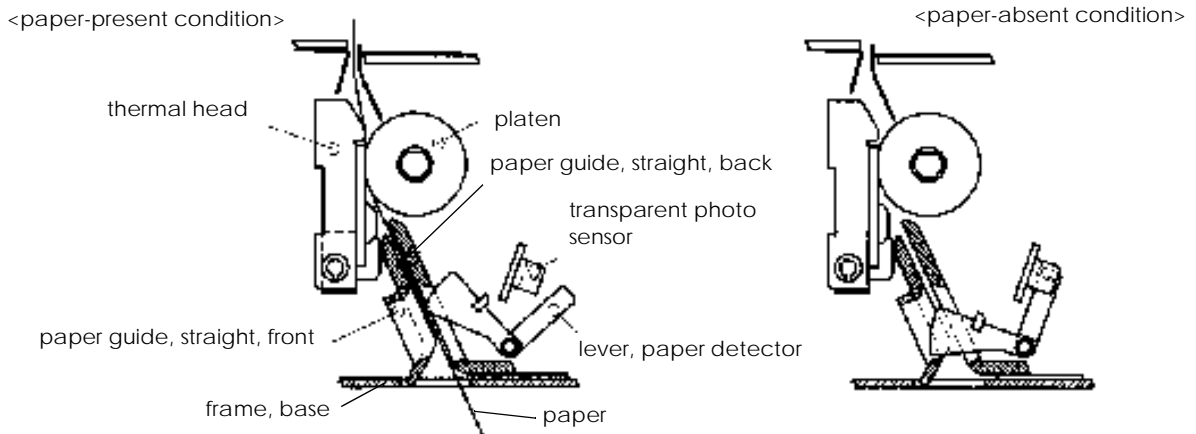

Figure 2-11 Paper-end detector mechanism

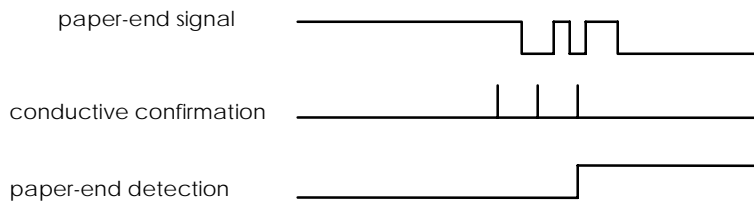

Figure 2-12 Paper-end detector operation

Platen-open detector mechanism

The platen-open detector mechanism has a **microswitch** which detects whether the **platen** is open (printing impossible because the **thermal head** is away from the **platen**) or closed (printing possible). The **microswitch** can be OFF only when the frame, **platen** is perfectly closed, and at all other times is ON.

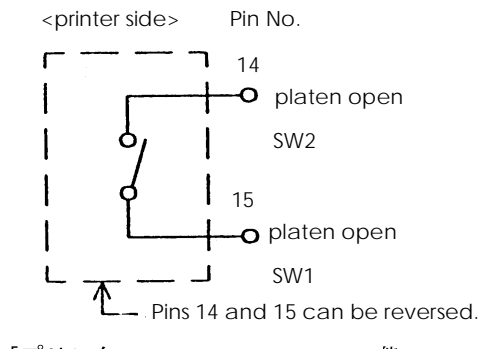

Figure 2-13 Platen-open detector circuit

Head temperature detector mechanism

The thermal head has a **thermistor** to detect the temperature of the **thermal head**.

Black mark detector mechanism

The black mark mechanism is a device which can be attached inside the paper guide mechanism to determine the printing position when using pre-printed thermal paper. This mechanism uses the reflective photo sensor.

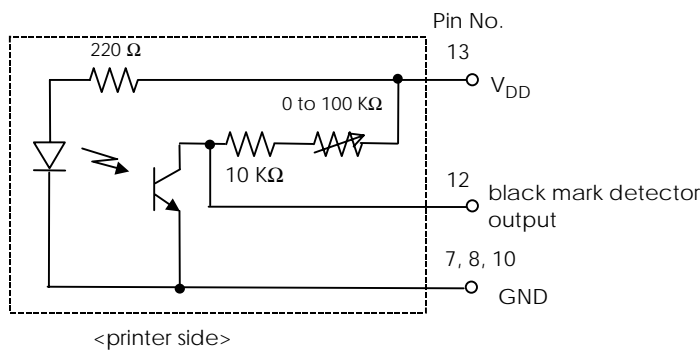

Figure 2-14 Black mark detector circuit

Black marks are detected through changes in output level from the reflective photo sensor. The changes in reflectivity between the pre-printed black marks and blank areas of the thermal paper cause the amount of light returning to the sensor to vary; then the sensor output level is also varied as shown in Figure 2-15. These variations are used to detect the black mark. Since the relationship between the black mark and the print position can be specified in the printer set up, detecting the black mark permits the correct positioning of the paper.

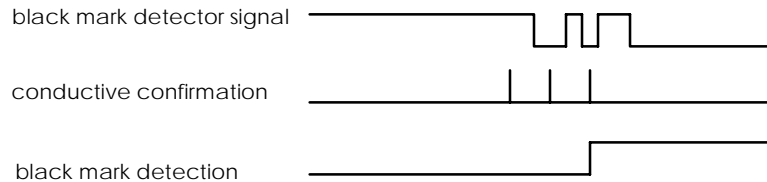

Figure 2-15 Black mark detecting operation

Autocutter Mechanism

This mechanism consists of the fixed blade mechanism, the movable cutter blade mechanism and the emergency cutter mechanism.

The basic principle of the autocutter mechanism is an application of the scissors principle, where the paper is cut by two crossing blades. A configuration which allows the two blades to separate has been adopted so that the fixed blade separates from the movable cutter blade, full when the platen is open.

Fixed blade mechanism

This mechanism is mounted on the frame platen unit. This configuration consists of the fixed blade which cuts the paper directly, the spring, fixed blade which stabilizes the vertical positioning of the fixed blade, and the cover, fixed blade which covers the fixed blade and is a paper guide as well as makes the operation to open the platen safe.

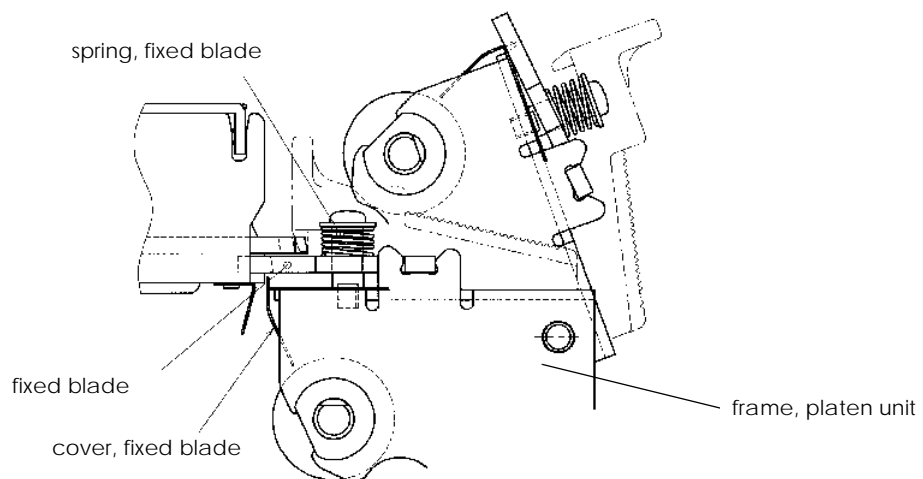

Figure 2-16 Fixed blade mechanism

Movable cutter blade mechanism

This mechanism is mounted on the frame, base.

The drive force transmission mechanism is on the cover, cutter side. The motor, cutter is a DC brush motor on the gear, cutter motor. It supplies the power and is attached on the cover, cutter with screws. The gear, reduction A/C and the gear, cutter worm are supported by the shaft, reduction A/C, and the gear, cutter drive is attached with push nuts to the shaft, cutter drive gear fixed on the cover, cutter.

After being transmitted through the gear, reduction A/C and the gear, cutter worm, the power is transmitted to the gear, cutter drive. The gear, reduction A/C is pushed against the gear, cutter worm by the spring, cutter clutch and the washer, Clutch, forming a one-way clutch which is used to cut off the transmission of power when the transmitted load exceeds a prescribed level during paper cutting.

The rotational movement of the gear, cutter drive is transmitted to the back and forth movement of the movable cutter blade by being engaged with the shaft, movable cutter blade drive with the oval hole of the movable blade on the frame, cutter. Also, the microswitch attached to the cover, cutter is connected to the gear, cutter drive, enabling it to detect the position of the movable cutter blade. The lead wires of the motor, cutter and the microswitch are bound together and connect to the circuit board.

The shaft, movable cutter blade is on the frame, cutter side. The receiver, movable cutter blade, the spacer, movable cutter blade, the spring, movable cutter blade and the washer, movable cutter blade spring are mounted on the shaft, movable cutter blade in a group with a push nut.

When putting the cover, cutter and the frame, cutter together, engage the shaft, movable cutter blade drive with the oval hole of the movable cutter blade, and secure the cover, cutter and the frame, cutter with screws.

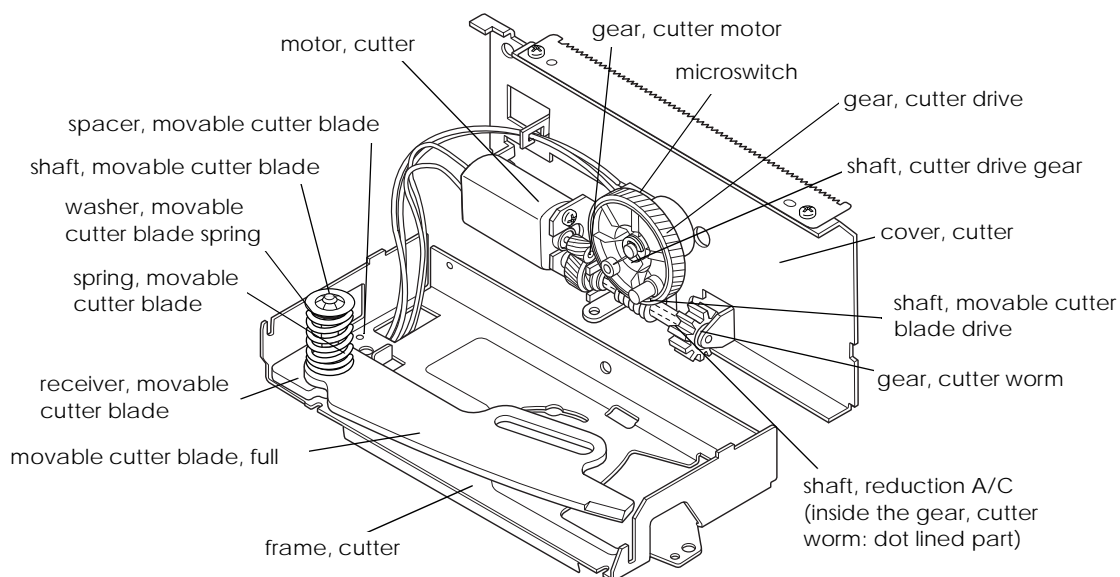

Figure 2-17 Movable cutter blade mechanism

Autocutting operation

The autocutter will operate when the frame platen unit is closed and a paper is loaded. (The frame platen unit can be closed when the **movable cutter blade, full** is in the standby position. The autocutting operation is performed in the following steps:

1. Drive the motor, cutter in the forward rotation.
2. The microswitch is switched from OFF (open) to ON (closed) while the motor, cutter continues to rotate in the forward rotation. The **movable cutter blade, full** intersects with the **fixed cutter blade** and cuts the paper from the right to the left, toward the first column.
3. After cutting the paper, the **movable cutter blade, full** starts to return to the home position.
4. As the **movable cutter blade, full** approaches the home position, the microswitch is switched from ON (closed) to OFF (open); then the motor, cutter stops rotating and the brake is applied.

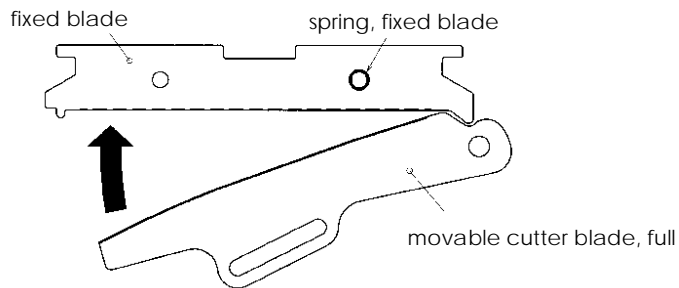

Figure 2-18 Auto cutting operation

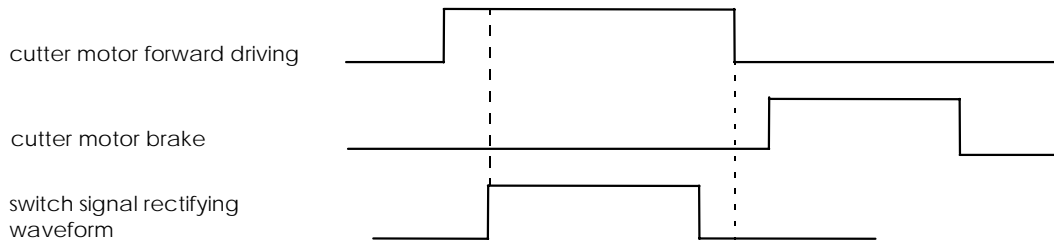

Figure 2-19 Auto cutting control example

 **Note:**

If the movable cutter blade, full cannot be returned to the home position because of foreign matter locking the blade when powered by the motor, rotate the knob on the gear, cutter worm with a tool such as a ball-point pen or tweezers to move the movable cutter blade, full to the home position. The window on the cover, cutter can be used to check if the movable cutter blade, full has returned to the home position.

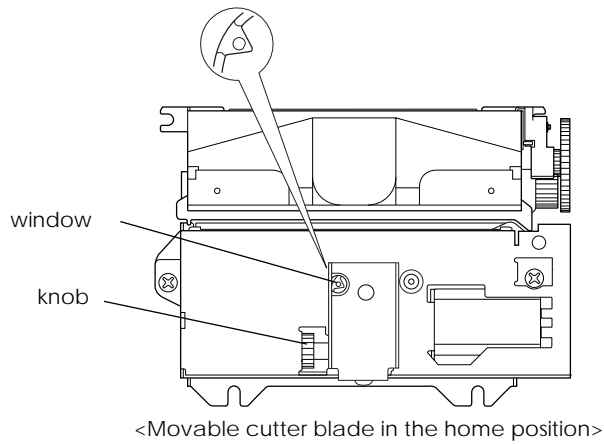

Figure 2-20 Home position check

Cut Sheet Presenter Module

The cut sheet presenter module has a mechanism to feed the paper printed and cut by the printer module to the paper exit.

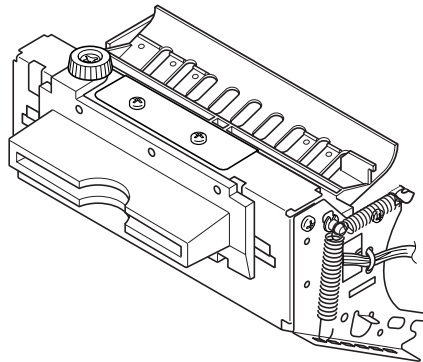

Figure 2-21 Appearance of cut sheet presenter module

Paper Feeding Operation (With a Loop)

A paper feeding operation is performed at the same time with the start of the paper feeding of the printer module. The motor, cutting paper feed rotates in the clockwise direction as seen from the shaft direction, and the roller, presenter rotates in the clockwise direction via the gears. The roller, cutting paper hold is pressed to the roller, presenter by a spring.

The paper sent from the printer module is fed along the paper guiding part, and fed between the roller, presenter and the roller, cutting paper hold. When the tip of the paper reaches the detection position of the paper presence sensor, the motor, cutting paper feed stops temporarily.

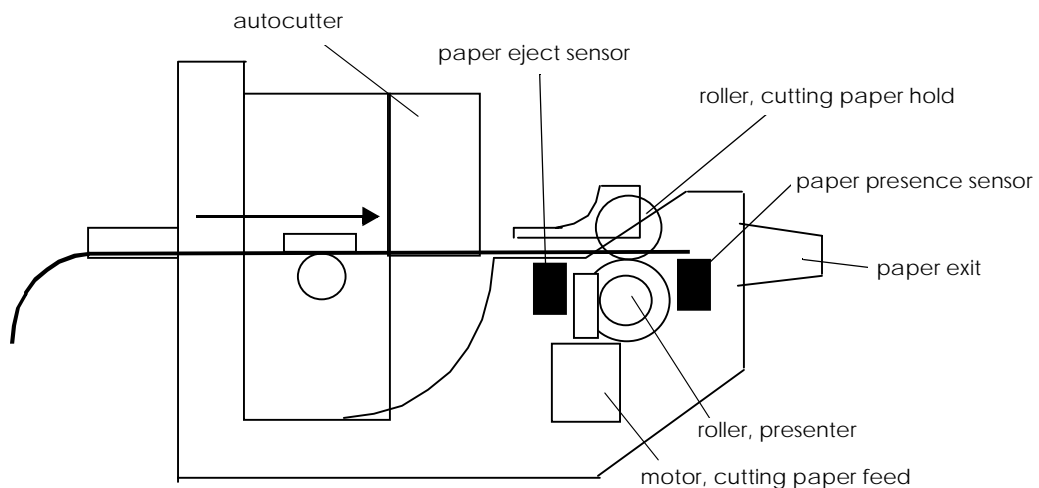

Figure 2-22 Start of the cut sheet feeding

While the tip of the paper sent from the printer module is in the standby state between the roller, presenter and the roller, cutting paper hold, the paper is continuously fed from the printer module. The paper pushes up the paper guide, upper and temporarily forms a loop.

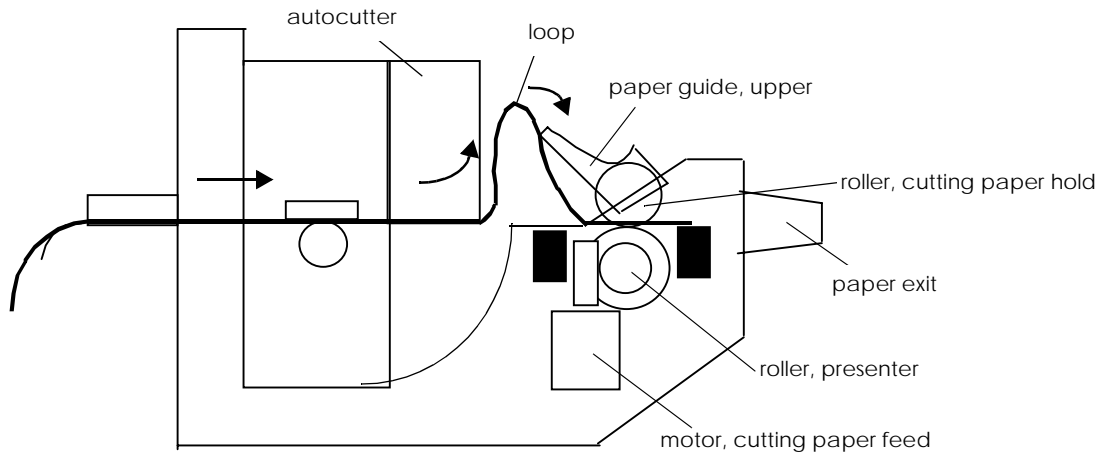

Figure 2-23 Cut Sheet with Loop

When the paper feed from the printer module is finished, the cutter on the printer module cuts the paper; then the motor, cutting paper feed resumes rotating and the cut sheet is fed from the roller, presenter to the paper exit.

When the paper eject sensor detects the end of the cut sheet, the motor, cutting paper feed stops. With the cut sheet between the roller, presenter and the roller, cutting paper hold, a series of operations is completed and the cut sheet is ejected from the paper exit.

A paper presence sensor can detect whether or not the cut paper is removed.

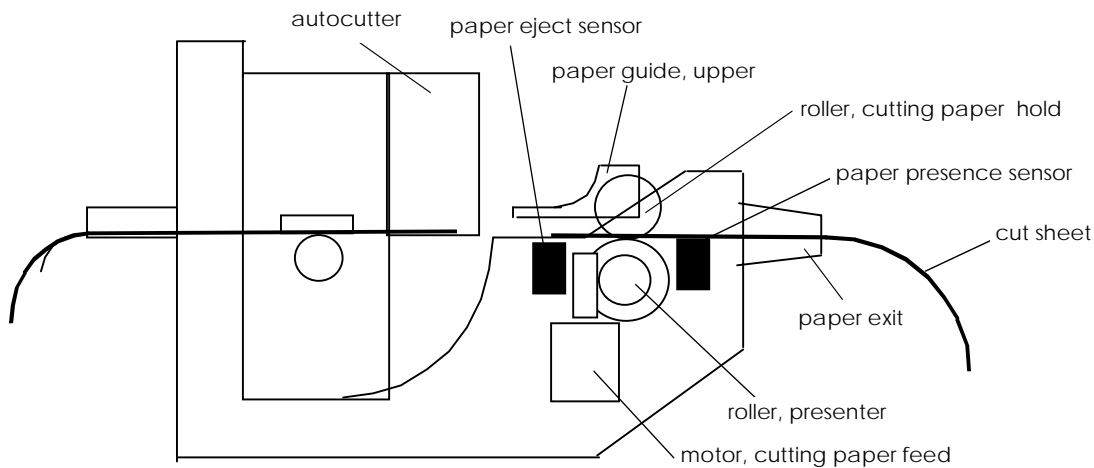

Figure 2-24 End of the Cut Sheet Feeding Operation

Paper Feeding Operation (Without a Loop)

The cut sheet presenter module can feed paper without forming a loop.

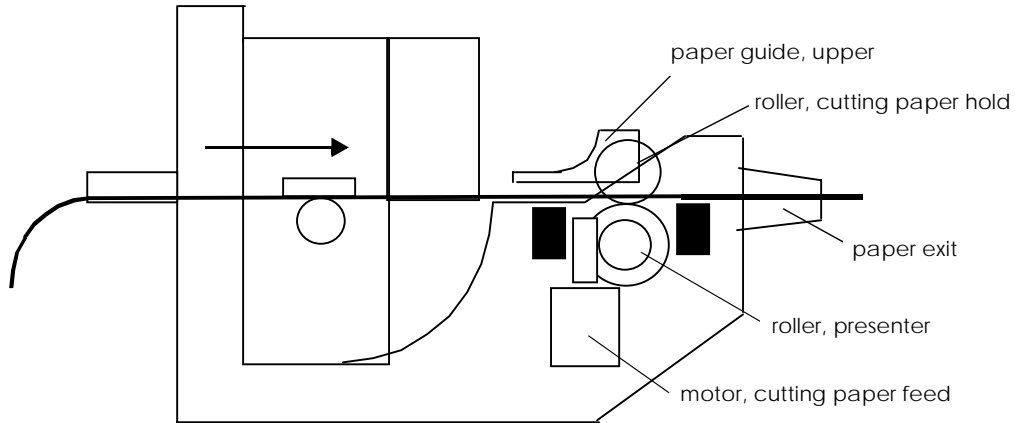

Figure 2-25 Cut Sheet Operation without Loop



Note:

During paper feeding operations without a loop, do not pull out the paper.

Detector Mechanism

The detector mechanism consists of the presenter open sensor, the paper eject sensor, and the cut sheet presence sensor.

Presenter open sensor

This sensor detects whether the cut sheet presenter module is open or not.

Paper eject sensor

This sensor detects the paper presence in the paper feeding route.

Cut sheet presence sensor

This sensor detects whether or not the cut sheet has been removed.

Control Circuit Board Module

The control circuit board module controls all functions of each module and has the interface connectors and the power supply terminals. Each function can be set by using the DIP switches and the memory switches.

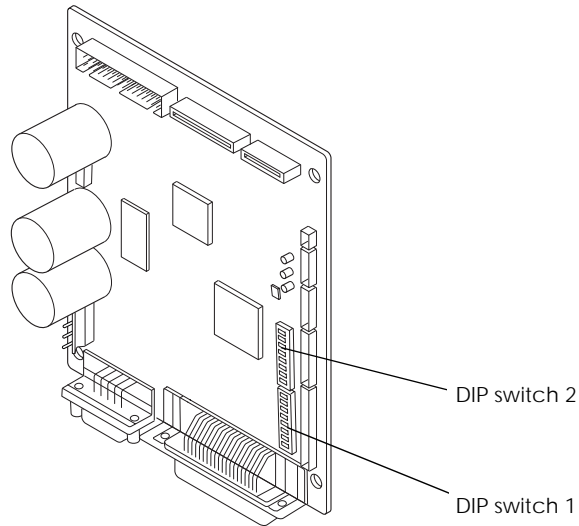

Figure 2-26 Appearance of the control circuit board module

DIP Switches

The circuit board has two DIP switches (DSW 1/2). Each setting is as follows:

DIP Switch 1

Table 2-1 DSW 1

SW No.	Function	ON	OFF	Default Setting
1	Black mark detecotor	Enabled	Disabled	OFF
2	Interface selection	Refer to Table 2-2		
3				
4	Serial interface handshaking	XON/XOFF	DTR/DSR or CTS/RTS	OFF*
5	Serial interface parity check	Yes	No	
6	Serial interface parity selection	Even	Odd	
7	Serial interface baud rate selection	Refer to Table 2-3		
8				

*: Effective only when the serial interface is selected.

Table 2-2 Interface Selection

Interface	Switch No. 2	Switch No.3
Parallel interface (IEEE1284)	OFF	OFF
Serial interface (RS232)	OFF	ON
Optional interface	ON	ON or OFF

Table 2-3 Baud Rate Selection

Transmission speed (bps)	Switch No.7	Switch No.8
4800	ON	ON
9600	OFF	ON
19200	ON	OFF
38400	OFF	OFF

bps: bits per second

DIP Switch 2

Table 2-4 DSW 2

SW No.	Function	ON	OFF	Default setting
1	Model type selection	Refer to Table 2-5		ON
2				OFF
3	Print density selection	Refer to Table 2-6		
4				
5	Operation mode selection	Refer to Table 2-7		OFF (*1)
6	Factory use			
7	I/F pin 6 reset signal-1	Enabled	Disabled	OFF (*2)
8	I/F pin 6 reset signal-2	Enabled	Disabled	

(*1): Fixed to OFF

(*2): Effective only when the serial interface is selected.

Table 2-5 Model Type Selection

Model	Switch No.1	Switch No.2
79.5 mm {3.15"} paper-width model: 576 dots)	ON	OFF

Table 2-6 Print Density Selection

Level	Print Density	Switch No.3	Switch No.4
1	Slightly light	ON	ON
2	Normal	OFF	OFF
3	Slightly dark	ON	OFF
4	Dark	OFF	ON

Table 2-7 Operation Mode Selection

Operation mode	Switch No.5
Hexadecimal dump	ON
Normal	OFF

Notes:

- Changes in DIP switch settings (excluding switches 2-7 and 2-8 ,interface reset signals) are recognized only when the printer power is turned on or when the printer is reset by using the interface.
- If you turn on DIP SWs 2-7 and 2-8 while the printer power is turned on, the printer may be reset, depending on the signal state. DIP switches should not be changed while the printer power is on.

Memory Switches

Other settings except DIP switches 1 and 2 are set by the memory switches. (The settings are changed with a **GS (E** command, and also can be changed by using the MEMSW.exe included with EPSON Advanced Windows Drivers.) The settings of the memory switches are as follows:

Table 2-8 Memory Switch 1

SW No.	Function	ON (1)	OFF (0)	Default setting
1	Reserved	—	Fixed to OFF	OFF(0)
2				
3	BUSY condition	Receive buffer full	Receive buffer full or offline	OFF(0)
4	Receive error	Ignored	Prints "?"	OFF(0) (*1)
5	Auto line feed	Always enabled	Always disabled	OFF(0) (*2)
6 to 8	Reserved	—	Fixed to OFF	OFF(0)

(*1): Effective only in the serial interface model.

(*2): Effective only in the parallel interface model.

Table 2-9 Memory Switches 2 to 5

SW No.	Function	ON (1)	OFF (0)	Default setting
1 to 8	Reserved	—	Fixed to OFF	OFF(0)

Table 2-10 Memory Switches 6

SW No.	Function	ON	OFF	Default setting
1 to 2	Reserved	—	Fixed to OFF	OFF(0)
3	Print speed control	Speed has priority over power consumption	Power consumption has priority over print speed	OFF (0) (*1)
4	Auto eject if the paper out is detected	Disabled	Enabled	OFF (0) (*2)
5	Reserved	—	Fixed to OFF	OFF (0)
6	Selection of type of thermal paper	Excellent preservation paper (thick type)	Normal	OFF (0) (*3)
7	Reserved	—	Fixed to OFF	OFF (0)
8	Selection of the operation of GS FF	Disabled	Enabled	OFF (0)

(*1): This setting is used for selecting the following modes:

<Power consumption has priority over print speed>

In this mode, the printer operates with power consumption as low as possible.

<Print speed has priority over power consumption>

In this mode, the printer prints at the maximum speed.

If the printer power is supplied with a power source that is less than 100 W, do not turn on the print speed mode.

(*2): This setting specifies the printer's operation if a paper out is detected during printing and feeding.

Enabled: Ejects paper automatically

Disabled: Does not eject paper (from the presenter)

(*3): The print energy is applied according to the table below.

The values in the table below are relative ones, assuming that the print energy for normal paper with normal density is 100 %.

Table 2-10-1 Print Density Selection

Memory SW6-6	ON	OFF
Slightly light	100%	85%
Normal	115%	100%
Slightly dark	130%	115%
Dark	145%	130%

Table 2-11 Memory Switch 7

SW No.	Function	ON (1)	OFF (0)	Default setting
1	Reserved	—	Fixed to OFF	OFF(0)
2 and 3	Setting for the secondary paper near-end position	Refer to Table 2-12		OFF(0) (*1)
4	Operation after cutting	Ejects fully	Clamps	OFF(0) (*2)
5	Paper initializing operation when the power is turned on	Always cuts	Detects paper's tip	
6 to 8	Reserved	—	Fixed to OFF	OFF(0)

- (*1):
- Effective only for the model type with the paper roll supply module
 - This setting lets the printer tell the paper near-end by sending the secondary paper near-end status when the specified length of paper is fed after the primary paper near-end sensor in the paper roll supply module detects the paper near-end.
 - If the paper near-end sensor 2 is installed in the printer, the detecting result of the paper near-end sensor 2 becomes the secondary near-end status. (The setting of memory switches 7-2 and 7-3 are ignored.)
- (*2): Effective only when using with the cut sheet presenter module.

Table 2-12 Setting for Paper Near-end Detecting Position

Paper length (for the time between detecting the primary paper near-end with the near-end sensor and sending the status of the secondary paper near-end)	Memory SW No.7-2	Memory SW No.7-3
Approximately 5 m {196.85"}	OFF	OFF
Approximately 10 m {393.70"}	ON	OFF
Approximately 20 m {787.40"}	OFF	ON
Approximately 30 m {1181.10"}	ON	ON

Table 2-13 Memory Switch 8

SW No.	Function	ON (1)	OFF (0)	Default setting
1 to 2	Print control mode	Refer to 2-14		OFF(0)
3	Backward paper feeding	Enabled	Disabled	OFF(0) (*1)
4	Autocutter installation	Not installed	Installed	OFF(0)
5	Specific offline operation	Discards receive data	Keeps receive data	OFF(0) (*2)
6	Backward paper feeding amount	88 steps	108 steps	OFF(0)
7	Test print when the paper is loaded	Enabled	Disabled	
8	Reserved	—	Fixed to OFF	

(*1): Do not set SW 3 to ON in the following condition:

- The partial cutter is used when the cut sheet presenter module is not used.

When backward paper feeding is enabled, the following process is executed.

- After cutting the paper with a **GS V** command, backward paper feeding is executed (when the Black mark detector is disabled).
- The print starting position adjustment with a **GS (F** command can be set to the backward direction relative to the cutting position. In this case, the maximum backward correction value is 14 mm {0.55"} (112 step × 0.125 mm {0.005"} per step).

(*2): Specific offline means the following states.

- Error state except an automatic recovery error state
- Platen open
- Cut sheet presenter module or cover open
- Paper empty

If this switch is turned on, the printer clears the receive buffer when the offline status shown above occurs. Then the printer executes any real-time command (**DLE ENQ**, **DLE EOT**) if it is there, and discards all other data. When the receive buffer is cleared, if this switch is turned on, three bytes of data, 37H, 24H, and 00H, are transmitted.

Table 2-13 Print Control Mode Selection

Default for the print control mode	SW 1	SW 2
Non-divided energizing mode	OFF	OFF
Two-part energizing mode	ON	OFF
Four-part energizing mode	×	ON

x: can be either setting

Chapter 3

Handling

Precautions

Transport Precautions

- ❑ When shipping the printer, use antistatic packing materials.
- ❑ Remove the paper roll when transporting the EU-T432.
- ❑ Make sure to close the paper roll supply module, the platen unit of the printer module, and the cut sheet presenter module when transporting.

Carrying Precautions

- ❑ Hold the paper roll supply module and the handle (a part with a green sticker on it) on the paper roll supply module when carrying the printer as shown below. When this product is equipped with an optional loop guide, you can hold the loop guide to carry it.



Note:

Do not hold parts other than those mentioned above; otherwise you can cause damage or deformation of parts that will affect the operation of the printer.

- ❑ When you put this unit on a place such as a desk, be sure to put it on a flat place; otherwise, a malfunction may occur because of deformation of parts.

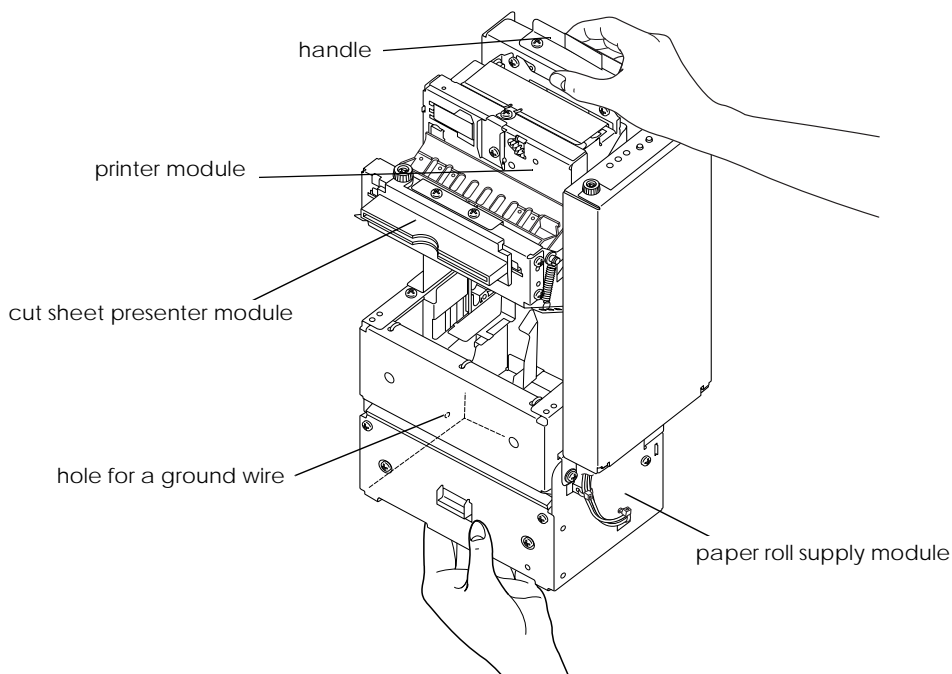

Figure 3-1 Correct way of holding the EU-T432

Installation Precautions

- ❑ When installing the unit, firmly secure four mounting parts at the bottom of the paper roll supply module to the system side with screws.
- ❑ Make sure to ground the unit by using the hole for a ground wire on the side of the frame. (See Figure 3-1 for the position.)



Note:

If the system side where the unit is installed is not flat, that could cause deformation of parts and malfunction. (It is recommended the difference in level is 0.3 mm {0.012"} or less.)

Handling Precautions

Paper roll supply module

- ❑ Do not apply excessive pressure to the **paper roll supply module** when opening or closing it; otherwise, the unit may not open and close properly because of deformation of parts.
- ❑ Do not touch the light emission or receiving surfaces of the **paper NE detector**; otherwise you may cause damage from dirt or static electricity.

Printer module



CAUTION:

Since the thermal head area and the motor surface can be hot during and right after printing, never touch them with your bare hands; allow about 15 minutes for them to cool.

- ❑ Since the EU-T432 contains permanent magnets (in the motor) as well as electromagnets, they should not be used in an environment with excessive dirt, dust, or metallic dust.
- ❑ Never print without paper installed or with the head away from the **platen**, because the life of the **thermal head** may be shortened.
- ❑ Never pull out the paper (forward or backward) with the head down (against the **platen**).
- ❑ Do not turn off the power during operations, especially during a cutting operation; otherwise the cutter blade could be exposed, leaving the **platen unit** difficult to open.
- ❑ Since the head heating elements and the driver IC are very delicate, avoid touching them with any metal objects such as tweezers or screwdrivers.
- ❑ Open the **platen unit** only when required.
- ❑ Never touch the surface of the head heating elements or the driver IC because dirt may stick to them, affecting the head heating elements or causing damage from static electricity.
- ❑ Before handling the **thermal head**, use proper body grounding procedures to avoid damage from static electricity.

- ❑ Make sure no dust collects on the thermal paper.
- ❑ Since the printer uses a line thermal print head, condensation must be avoided. If condensation occurs, do not turn on the printer until it has disappeared.
- ❑ Do not apply excessive pressure to the lever, platen when opening or closing the platen unit with the lever.

Cut sheet presenter module

CAUTION:

Since the paper feed motor surface will be hot after printing for a long period of time, never touch them with your bare hands; allow about 15 minutes for them to cool.

- ❑ Since the EU-T432 contains permanent magnets as well as electromagnets in the motor, they should not be used in an environment with excessive dirt, dust and metallic dust.
- ❑ Operate the cut sheet presenter module only when required. Do not apply excessive pressure when operating the cut sheet presenter module.
- ❑ Do not turn off the power during operations because that could cause a paper jam.

Control circuit board module

The serial interface is secured with inch-type hexagonal lock screws. If you need to use millimeter-type screws, replace the inch-type screws with the millimeter-type screws enclosed in the box.

Paper roll

- ❑ Use only the recommended thermal paper because thermal paper contains a high ion content such as Na, K and Cl may damage the head heating elements.
- ❑ Avoid heat, humidity, sunlight and solvents, regardless of whether or not the paper has been used. (Thermal paper gradually darkens at about 70°C {158°F}.)
- ❑ Remove the installed paper roll when the unit is not used for a long time in a high temperature or high humidity condition; otherwise the thermal sensitive materials contained in the thermal paper may stick to the thermal head area, affecting the printing quality.
- ❑ Label sheets are not available for the EU-T432.

Storage Precautions

- ❑ Do not store the printer in environments with excessive dust, high temperature, high humidity, or in direct sunlight.
- ❑ Before storing the EU-T432 for an extended time, remove the paper and wipe off dirt and dust; then clean parts such as the **platen** and the **thermal head** of the printer module with alcohol. After the alcohol evaporates, close each module and store the unit.



Note:

If you leave the printer with the paper installed, discoloration of the paper and stickiness between the paper and the platen may occur. In this case, replace the paper.

- ❑ Storing the printer for an extended period with the **platen** closed could cause the platen rubber to deform and result in defective printing. If the platen rubber is deformed, it can be restored to its proper shape by feeding paper through the printer. Just feed paper through the printer until the **platen** works properly; then resume printing.

Opening and Closing Modules, Unit and Part

Follow the steps below to open and close modules, unit, and part you want. See Figure 3-2 on page 3-5.



Note:

- ❑ *Do not apply excessive pressure to any operational part; otherwise its function may be damaged because of deformation or damage of the part.*
- ❑ *Apply pressure to each operational part only in the specified direction; otherwise its function may be damaged because of damage or deformation of the part.*

Paper Roll Supply Module



Note:

When opening or closing the paper roll supply module, make sure to secure the bottom of the module.

1. While holding down the **frame open lever** to unlock the paper roll supply module, pull the **plate, opening and shutting** or the optional **loop guide** to the near side (in the direction of arrow A) and turn the paper roll supply module to open it.
2. To close the module, push it back in the opposite direction of arrow A until it stops. At this time, make sure that the **frame open lever** is securely engaged with the fixing part. (Make sure the module is not open when it is pulled in the direction of arrow A.)

Platen Unit

1. To open the unit, hold down the lever, **platen** (green lever) of the printer module.
2. To close the unit, turn the lever, **platen** upward.

Cut Sheet Presenter Module

1. Put your fingers on the top and bottom of the cut sheet presenter module; then pull the module up at an angle (in the direction of arrow B) to slide it.
2. Pull the module until the mounting dowels on both sides of the module are disengaged; then turn the module downward and open it.
3. To close the module, lift up the bottom of the paper exit and slide it back to the original position. At this time, make sure that the mounting dowels (on both sides) are securely engaged with the mounting parts on the cut sheet presenter module.

Paper guide, upper

To open the paper guide, upper, lift up the knob on the right edge of the paper guide.

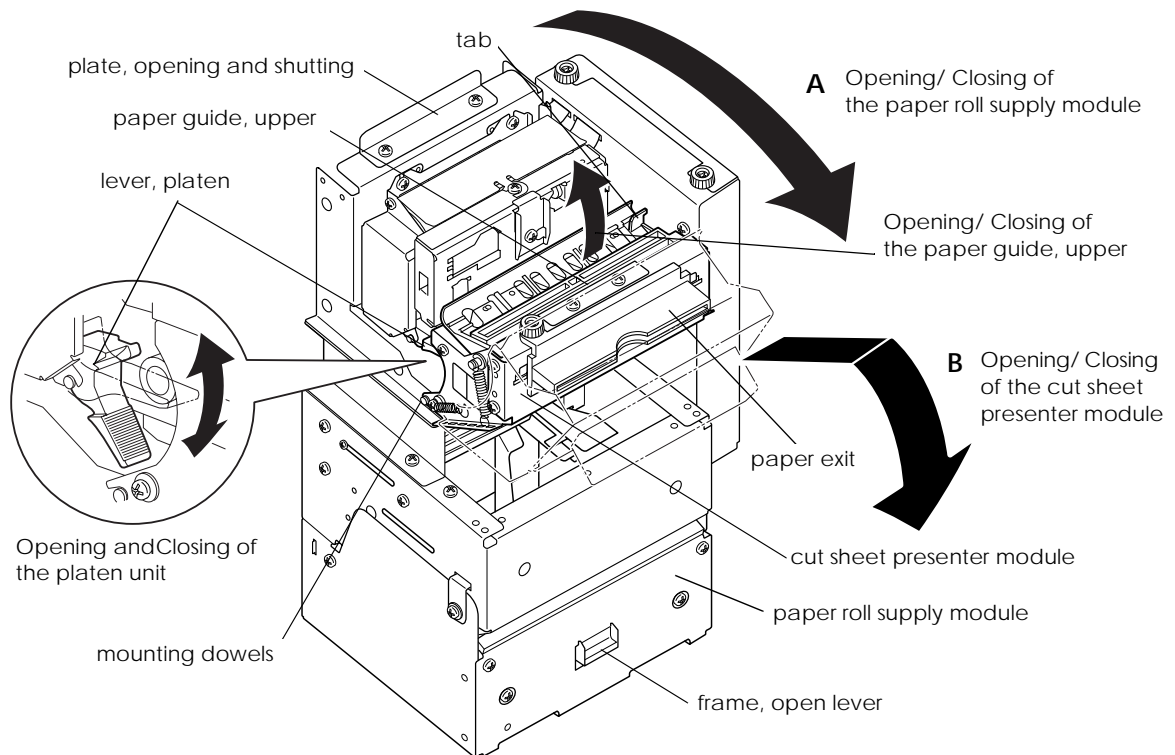

Figure 3-2 Opening/closing units and module

Loading and Removing a Paper roll

Loading a Paper roll

Follow the steps below to load or remove the paper roll. See Figure 3-3 on page 3-7.



Note:

Use only the paper specified in the EU-T432 specifications issued by Seiko Epson Corporation.

Loading paper for the paper roll supply module

1. Open the paper roll supply module. (See “Opening and Closing Modules and Other Parts” on page 3-4.)
2. Remove the shaft, roll paper holder from the roll paper holder. (Since there are two springs on the right and left sides of the shaft to keep it from being accidentally removed, pull the shaft toward the groove on the paper holder to remove it.)
3. Attach a holder, roll paper which meets the inside diameter of the paper core to the shaft, roll paper; then secure it with a C-ring.



Note:

At the default setting, the holder, roll paper A (for the 25.4 mm {1"} inner diameter paper core) is attached to the paper roll supply module. Since other holders are available as optional parts, use the holder, roll paper that meets your paper core size. The holder, roll paper B is for a 50.8 mm {2"} inner diameter paper core, and the holder, paper roll C is for a 76.2 mm {3"} inner diameter paper core.

4. Load the paper roll to the holder, roll paper until it stops against the flange of the holder.
5. Facing the printing surface upwards, install the holder, roll paper to the roll paper holder. After installing, make sure that the paper roll is secured by the two springs on both sides.



Note:

Make sure that the paper roll is loaded with the printing surface facing upwards.

6. Turn the paper roll supply module back to its original position until it is locked by the frame open lever with a click sound. Then turn it back so that the plate, paper guide is not deformed.

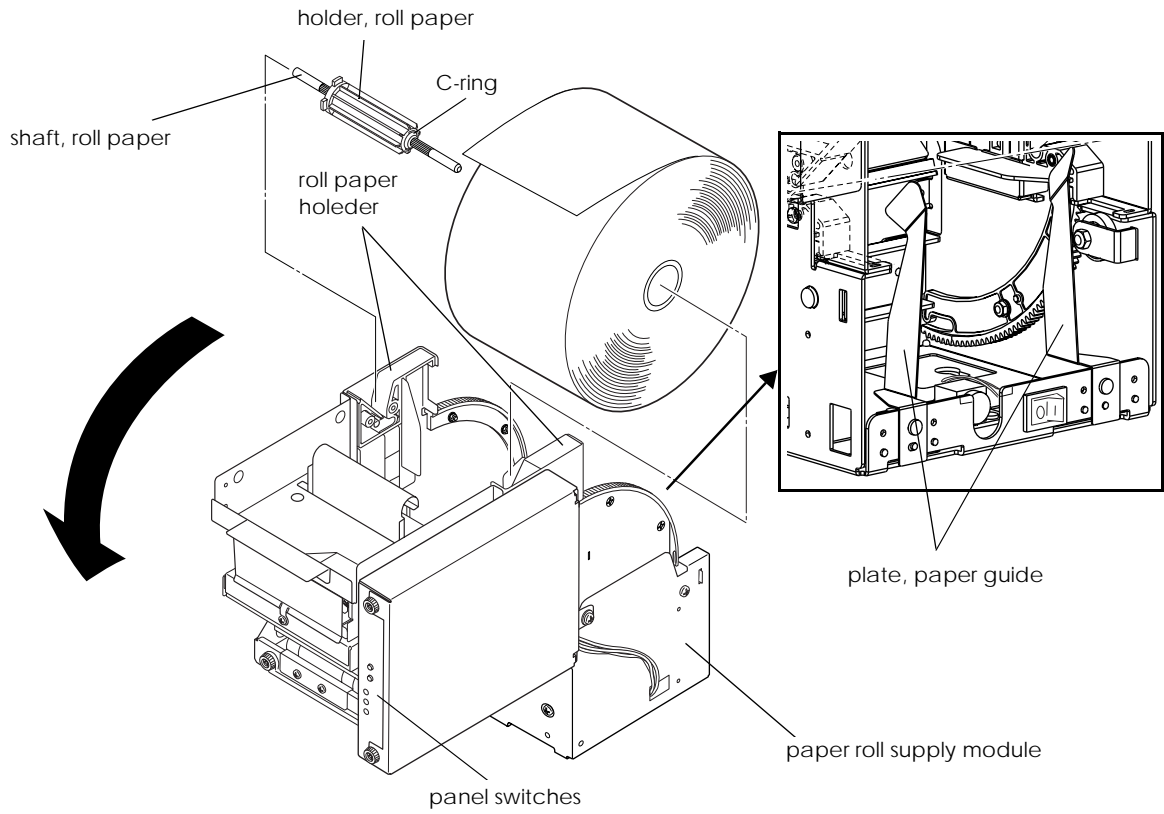

Figure 3-3 Loading and removing the paper roll

Loading paper for printer module

Follow the steps below to load the paper for the printer module from the paper roll supply module.

1. Cut the edge of the paper as shown below.

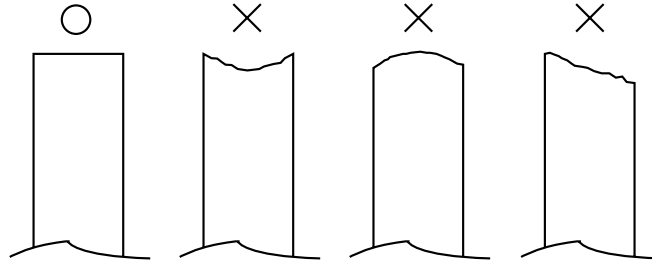

Figure 3-4 Shape of paper edge

2. Pull out a certain amount of paper.
3. After inserting the paper edge straight into the paper slot of the printer module so that the paper is along the upper side of the **plate**, **paper guide**, push the paper with your hand.
4. When the paper is detected by the **paper-end detector** of the printer module, it is fed automatically in the semi-autoloading mode.
5. When the semi-autoloading is finished, the extra paper is cut automatically.
6. Remove the extra paper from the **paper exit**.



Note:

- *Performing operations other than above can cause improper paper feeding and jamming.*
- *Make sure that the paper is not wrinkled or torn.*
- *To avoid paper jams, do not fold the edge of the paper.*
- *Paper curled in the opposite direction to the paper entrance may be difficult to insert.*
- *If the paper is not inserted at a right angle, paper jams or paper folding may occur. In this case, open the **platen unit** and load the paper properly after removing the jammed paper.*

Removing Paper

Follow one of procedures below to remove the paper roll.

Removing paper using BACK and FEED buttons

You can remove the paper using the BACK and FEED buttons. If you push the FEED button while holding down the BACK button, the paper will be fed backwards. After the paper is ejected, the paper roll can be removed using the same steps in “Manual paper removing.”

Removing paper using command

While the printer is online, you can also remove the paper using a FS (z command. If you use the FS (z command, the paper will be fed backward until it is detached from the platen. After the paper is ejected, the paper roll can be removed using the same steps as in “Manual paper removing.”

Manual paper removing

1. Turn the lever, platen to open the platen unit.
2. Pull out the paper from the paper slot of the printer module.
3. Open the paper roll supply module.
4. Pull the paper upward and remove it from the paper roll supply module.
5. Remove the paper core from the holder, paper roll.

Removing Jammed Paper

Follow the steps below to remove jammed paper from each module. (See “Opening and Closing Modules and Other Parts” on page 3-4 when opening modules, if necessary.)

CAUTION:

Since the thermal head area and the paper feed motor surface of the printer module and the paper feed motor surface of the cut sheet presenter module will be hot right after printing, never touch them with your bare hands; allow about 15 minutes for them to cool.

Note:

- Never pull the paper out with the platen unit down.
- When using tools such as tweezers to remove paper pieces, avoid touching the head heating elements or the elements of each paper detector with them.

Removing Jammed Paper From the Cut Sheet Presenter Module

Open the cut sheet presenter module, and lift the paper guide, upper; then remove the jammed paper.

Removing Jammed Paper From the Printer Module

1. Open the cut sheet presenter module.
2. Turn the lever, platen to open the platen unit and remove the jammed paper.

Paper NE Detector Setting

This detector is mounted on the paper roll supply module. By adjusting the position of the detector, the detector can detect the amount remaining on the paper roll at the setting value. At the default setting, the amount remaining is set to be about 5 m {196.85"} when the paper tip is detected, and when using paper which has 25.4 mm {1"} inner diameter of the core, 33.4 mm {1.3"} outer diameter of the core, and the 65 µm paper thickness. When you want to change the setting, follow the steps below.

1. If the paper is loaded, open the paper roll supply module and remove the paper roll. (See "Removing Paper" on page 3-9.)
2. Loosen the screw, NE detector so that the paper NE detector can be moved in the direction of arrow in the illustration on next page.
3. Tighten the paper NE detector with the screw, NE detector at the position you want for the paper NE detector.

The hole numbers for the paper NE detector fixing hole and the paper roll diameters detected by the paper NE detector are as follows:

Table 3-1 Setting of the Paper NE Detector

	Hole No. 1	Hole No. 2	Hole No. 3	Hole No. 4	Hole No. 5	Hole No. 6	Hole No. 7	Hole No. 8	Hole No. 9
Detected paper diameter (for 6 inch types)	40 mm {1.56"}	50 mm {1.97"}	60 mm {2.36"}	70 mm {2.76"}	80 mm {3.15"}	90 mm {3.54"}	100 mm {3.94"}	110 mm {4.33"}	—
Detected paper diameter (for 8 inch types)	40 mm {1.56"}	50 mm {1.97"}	60 mm {2.36"}	70 mm {2.76"}	80 mm {3.15"}	90 mm {3.54"}	100 mm {3.94"}	110 mm {4.33"}	120 mm {4.72"}



Note:

- ❑ Because the amount remaining on the paper roll will vary with the paper types (thickness), make sure to check before setting.
- ❑ Do not touch the light emission or receiving surfaces of the paper NE detector with your hands or any objects since you may cause damage from dirt or static electricity.

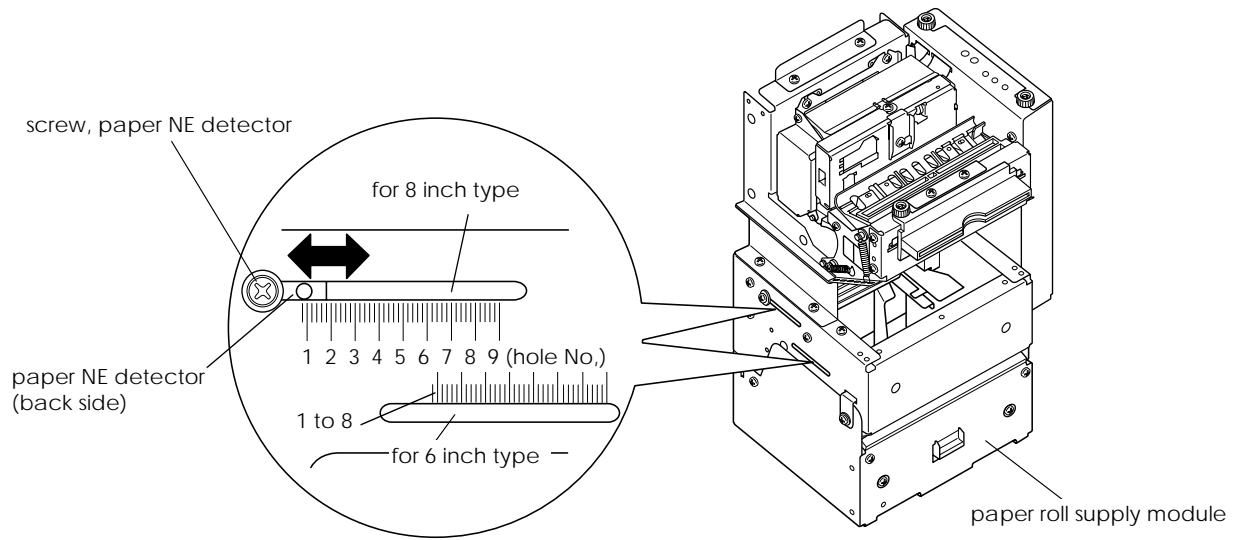

Figure 3-5 Setting of the paper NE detector

Self Test

The EU-T432 has self test functions. Follow the steps below to perform the self tests.

Performing the Self Test

1. With the paper loaded, turn on the power while holding down the FEED button on the panel switch. (If the power is already on, turn it off first before performing the self test with the paper loaded.)

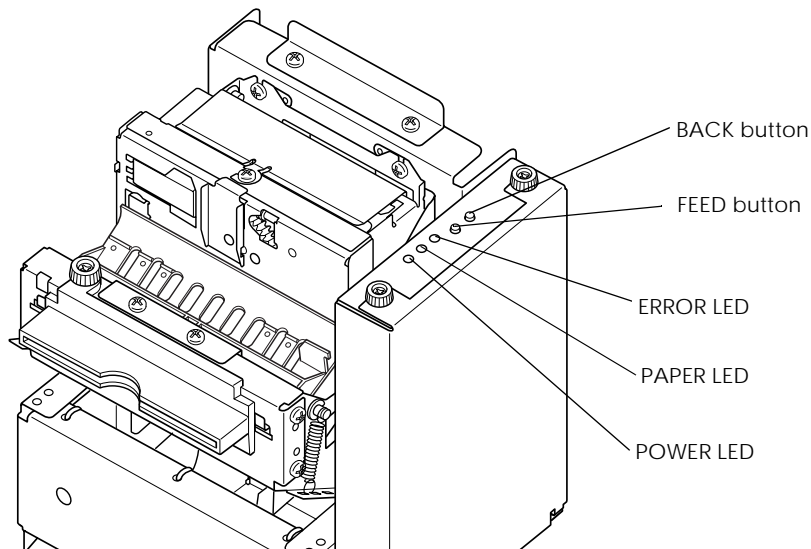

Figure 3-6 Performing the self test

2. The current printer status is printed.
3. When the printing is complete, the message, “If you want to continue **SELF-TEST printing, please press FEED button,**” is printed; then the PAPER OUT LED starts to flash.
4. Press the paper feed button again while the PAPER OUT LED is flashing; then the printing (for the test pattern printing) is resumed.

Self Test End

After a number of lines are printed, the message *****completed***** is printed at the end of the self test; then the unit enters the normal operational mode, with all settings initialized.



Note:

During the self test, check each LED on the circuit board. If an error occurs during the self test, see the following section and “Troubleshooting” in Chapter 5 for details.

Errors

LED Display

The LED indications indicate the following: the POWER LED for power supply error, the PAPER LED for paper-out error and the ERROR LED for various kind of errors. For the LED position, see Figure 3-6 “Performing the self test,” and for recovery from errors, see “Troubleshooting” in Chapter 5.

POWER LED (Power Supply Error): Green

When the POWER LED is lit, the power is supplied. The LED indicates the following:

Table 4-4 POWER LED Error

Error type	LED flashing pattern	Cause
Power supply error	Not lit	The power supply connector is unplugged.
		The fuse (F1) is blown out.

PAPER LED (Paper-End Error): Red

When the PAPER LED is not lit, the paper roll has enough paper on it. The LED indicates the following:

Table 4-5 PAPER LED Error

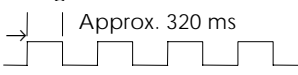
Error type	LED flashing pattern	Cause
Paper-end error	Lit	<ul style="list-style-type: none"> The paper roll is near its end or no paper is loaded. A paper jam has occurred around the detector. Detector failure has occurred. The connector of the detector is unplugged.
Waiting for self test printing to be continued or macro execution ready state	Flashing 	Self test printing is in the ready state during self test.

ERROR LED (Error): Red

ERROR LED has three error types: the automatic recovery error, the possible recovery error, and the recovery impossible error. The LED indicates the following:

Automatic recovery error

Table 4-6 Automatic recovery error

Error type	LED flashing pattern	Cause
Print head high temperature error		The head temperature has reached 75°C or more.

 **Note:**

The high temperature error of the print head is not an abnormality. When the head cools down to 70°C or less, the unit recovers automatically.

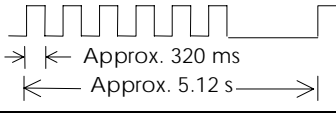
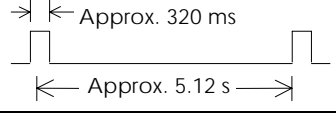
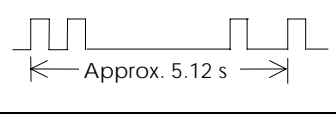
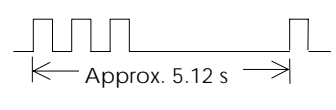

Possible recovery error

Table 4-7 Possible Recovery Error

Error type	LED flashing pattern	Cause
Platen open error		Platen unit is open during printing.
Autocutter error		Autocutter malfunction
Black mark sensor detection error		No black mark is detected even after a certain amount of paper with black mark is fed.
Presenter error		A paper jam has been detected in the cut sheet presenter module.

Recovery impossible error

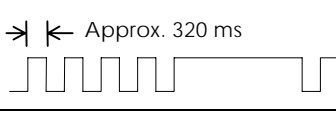
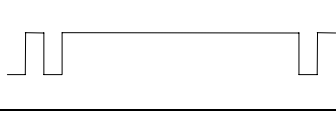
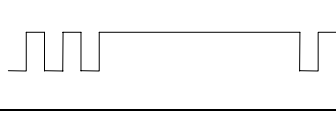
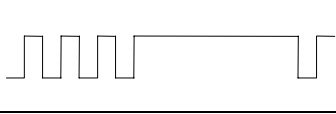
Table 4-8 Recovery impossible error

Error type	LED flashing pattern	Cause
CPU execution error		The CPU has executed an incorrect address.
R/W error in memory or G/A		After R/W checking, the printer does not work correctly.
High voltage error		The power supply voltage is extremely high.
Low voltage error		The power supply voltage is extremely low.
PCB connection error		The printer is not connected or the head wiring is disconnected.



Note:

When any error shown above occurs, turn off the power as soon as possible.

Chapter 4

Maintenance

To keep the printer in peak working condition, extend its life for a long term, and prevent operational failures, follow the maintenance procedures below.

Cleaning

CAUTION:

- Never clean the **thermal head** with solvents other than the specified ones, since other solvents could damage the **thermal head** or cause the malfunction of parts.
- Since the head area and each motor surface can become hot right after printing, allow about 15 minutes for them to cool.

Thermal Head Cleaning

The head heating elements of the printer module will collect dust after printing for a long period of time because of heat sensitive materials contained in the paper, that could affect printing quality. Therefore, cleaning the thermal head using the steps below is recommended. (See “Opening and Closing Modules and Other Parts” on page 3-4 for opening the module and the platen unit if necessary.)

1. Turn off the power.
2. Open the cut sheet presenter module.
3. Open the platen unit using the lever, platen, and remove the paper.
4. Wipe off the dust on the head heating elements using a cotton swab dampened with alcohol solvent, such as ethanol, or IPA.

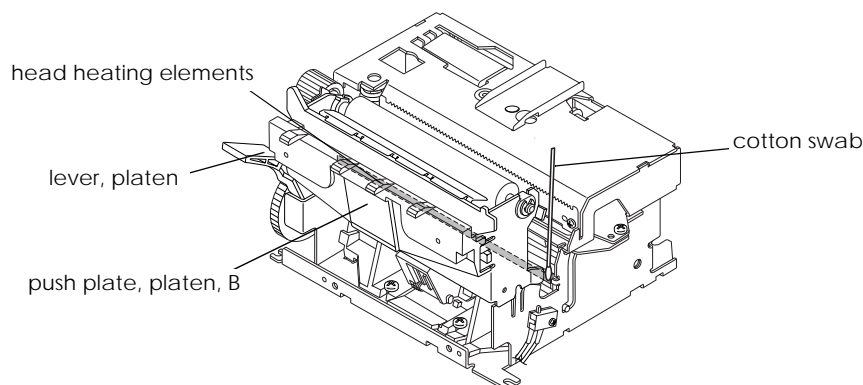

Figure 4-1 Thermal head cleaning

5. After the alcohol evaporates completely, turn the lever, platen or push the push plate, platen B to close the platen unit.

Removing Stains (Except for the Thermal Head)

The areas where the paper is fed will be stained or collect dust after printing for a long time because of paper dust and heat sensitive materials contained in the paper. Especially, if paper feed rollers, the platen, or the paper detectors are not clean, a malfunction in paper feeding or paper detection may occur. In this case, wipe off the stains with alcohol.

CAUTION:

Never use thinner, benzine, trichloroethylene, or ketone group solvents, since they could damage rubber and plastic parts or cause them to deteriorate.

Removing Dirt and Dust

Use an electronic vacuum cleaner to remove dirt and dust. After cleaning, check the lubrication point and lubricate when necessary.



Note:

When opening the units and cleaning them, be sure not to damage parts and paper detectors, disconnect wires, or unplug connectors.

Removing Foreign Matter When the Cutter Locks

Follow the procedures below to remove foreign matter when the cutter of the printer module locks.

After rotating the **motor** in reverse so that the **movable cutter blade, full** returns to the home position, shut off the current to the **motor**; then remove any foreign matter. (See Figure 2-20 on page 14 in Chapter 2 for checking the home position.)

If the **movable cutter blade, full** fails to return to the home position even after executing the above procedure, follow the steps below.

1. Shut off the current to the **motor**.
2. Rotate the knob on the **gear, cutter worm** with a tool, such as tweezers, so that the **movable cutter blade, full** returns to the home position; then remove the foreign matter.

Inspection

The maintenance and inspection procedures for the printer fall into two categories. One is “Daily checks” for the printer user, and the other is “Periodic checks” for someone with more technical knowledge. Maintenance and inspection procedures should be carried out by properly qualified personnel.

Daily Checks

Make sure the printer is used properly and kept in good repair. If there are any problems, correct them using procedures in the table below. The items to be checked are as follows:

Table 4-1 Daily Checks

Check item	Standard	Procedure
Setup status	No cables or connectors are disconnected.	Connect the cables or connectors properly.
	Paper roll is loaded properly.	Load the paper properly.
	No units or modules such as the paper roll supply module, the platen unit, the cut sheet presenter module, the cover, circuit board are open.	Close the units or the modules.
Paper chips or foreign matter inside the product	No paper chips or foreign matter is inside the product	Remove paper chips or foreign matter.
Paper state	Specified paper is used.	Replace with the specified paper
	No discolored or torn paper is used.	Replace with a new paper roll.

Periodic Checks

Every six months, check the items listed in the table below. If there are any problems, correct them using procedures in the table below.

Table 4-2 Periodic Checks

Check item	Standard	Procedure
Dust, fuzz, or dirt sticking to various parts	No dirt or dust is on any parts or collected in the paper path.	Remove dust, fuzz, or dirt with a vacuum cleaner.
	No paper chips or foreign matter is in the areas such as around the thermal head heating elements, the cutter, gears, detectors, and inside the paper path.	<ul style="list-style-type: none"> • Wipe off dirt and dust with alcohol. • Remove foreign matter or paper chips. • Wipe the platen surface with alcohol when paper chips have accumulated.
Lubrication status	Lubrication is satisfactory.	Lubricate the lubrication points if required.
Operating status	<ul style="list-style-type: none"> • Printing, paper feeding and issuing operations perform properly. • No abnormal sound • All other functions perform properly and parts are not deformed or worn. 	See “Troubleshooting” on page 5-2.

Lubrication

Lubrication is particularly important in keeping the printer operating properly as long as possible. Therefore, lubricate at prescribed intervals, using the correct lubricants.

Lubricant

The performance and durability of the printer are greatly affected by the lubricant applied. Therefore, pay careful attention to lubricant specifications, especially for the low temperature characteristics. The lubricants for the printer are chosen based on technical information analysis and tests on various lubricants by EPSON. The lubricants are available in 40 cc (gr.) plastic containers (the minimum supply unit). Both G-36 and G-15 are used on this printer.

Lubrication Standards

Lubricate the printer in the following situations:

- Lubricant is wiped off during cleaning.
- Lubricant is wiped off when disassembly or assembly is performed.

When lubricating parts during assembly of the printer, clean parts before lubricating them. Refer to the next section and “Lubrication Diagram” at the end of this manual for the lubricants and the lubrication points.

Lubrication Point

The lubrication points are as follows:

Table 4-2 Lubrication Point

Module	Number	Lubrication point	Lubrication type	Amount of lubricant
Printer module	1	Two points where the screw on the lock lever is secured	G-15	1 mm-diameter lubricant
	2 to 7	The seven points where the gears on the autocutter are engaged with other parts.	G-36	Appropriate quantity
	8	The oval hole on the movable cutter blade (Two points)	G-15	1 mm-diameter lubricant
	9	The two points where the cutter frame contact the fixed blade .	G-15	1 mm-diameter lubricant
	10	The two points where the shaft of the movable cutter blade rotates.	G-15	Appropriate quantity
	11	The dowels where the platen unit rotates.	G-36	Until the dowels are covered.
	12	The points where the frame assembly contacts the lock lever assembly .	G-15	1 mm-diameter lubricant
fixing plate, printer	13	Two points where the cut sheet presenter module turns	G-36	Appropriate quantity
Cut sheet presenter module	14	The gear on the paper feed motor	G-36	Appropriate quantity

Note: The lubrication point numbers in the table are the same as those in the lubrication diagrams at the end of this manual.

Lubricant List*Table 4-3 Lubricant List*

Type	Name	Quantity	Commercial availability
Grease	G-15	40 gr	Epson exclusive product
Grease	G-36	40 gr	

Tools*Table 4-4 Tool List*

Tool name	Commercial availability
Brush #1	Yes
Cleaning brush	Yes
Crosshead screwdriver #0, 1 and 2	Yes
ET holder No. 1.5, 2, 2.5, 3, 3.5 and 4	Yes
Tweezers	Yes
Diagonal cutting nippers	Yes
Pliers	Yes
Electric solder iron	Yes
Wrist band	Yes

Table 4-5 Measuring Equipment List

Name	Standard
Multimeter	DC voltage: 400 V max. Resistance: measurable
Oscilloscope	500 MHz with storage

Chapter 5

Repair

Repairs are divided into two levels (A and B) in consideration of the degree of difficulty of repair. The person who repairs the printer should perform the proper repair procedures, depending on the individual technical knowledge and skills.

Repair Levels

- Level A:** Requires general knowledge of the printer's operation principles and structure but does not require specialized experience.
- Level B:** Requires a certain degree of knowledge of the printer's operating principles and structure as well as skills and experience using special tools for disassembly and assembly of the printer.

Repair Procedure

When problems occur, check the condition of the printer and locate the cause of the problem as outlined in "Troubleshooting Table." Then repair the unit properly. The table consists of the following five sections.

- Phenomenon** Find the type of problem in this column.
- Condition** Check the condition of malfunction by referring to this column.
- Cause** Locate the cause of the problem by referring to this column. Also, the repair level is indicated for each cause; use this indication to determine the method of repair.
- Where/ how to check** The mechanisms that may cause problems as well as checkpoints are listed in this column. Check the unit as outlined in this column to locate the malfunctioning section.
- Procedure** Repair malfunctioning sections as indicated in this column. If the same problem or phenomenon reoccurs after the specified repair is performed, check other items in the "Cause" column and repair the unit again.

Troubleshooting

Use troubleshooting procedures in the table below when problems occur.

Table 5-1 Troubleshooting

Phenomenon	Condition	Cause	Level	Where/how to check	Procedure
No performance	Power (24 V) is not supplied	Power connector is disconnected.	A	See if the power connector is connected properly.	Connect the power connector again.
	POWER LED is not lit.	Fuse (F1) is blown.	B	Check with a tester if the fuse (F1) on the control circuit board is conductive.	<ul style="list-style-type: none"> •Replace the blown fuse. •Replace the control circuit board if there is no recovery after the fuse replacement.
PAPER LED is lit.	Paper out error	(1) Paper is not loaded in the printer.	A	Check if the paper is loaded.	Load the paper in the printer.
		(2) Only a small amount remaining on the paper roll (paper NE detected)	A	Check the amount of the paper remaining in the paper supply module.	Replace the paper roll if only a small amount of the paper remaining is left.
PAPER LED is not lit even when the paper is out.	Paper detector failure	(1) Paper chips or foreign matter is jammed around the paper detector.	A	Check whether paper chips or foreign matter is jammed around the paper detector.	Remove the paper chips or foreign matter if there is any.
		(2) Paper chips or foreign matter is jammed around the paper NE detector.	A	Check whether paper chips or foreign matter is jammed around the paper NE detector.	Remove the paper chips or foreign matter if there is any.
PAPER LED is lit even when the paper is not out.	Paper detector failure	(1) Paper NE connector is disconnected.	A	Check if the paper NE detector is connected properly.	Connect the connector properly if it is disconnected.
		(2) Paper NE detector is damaged.	B	Check the paper NE detector function with an oscilloscope.	Replace the paper NE detector if it is damaged.
		(3) Paper detector is disconnected.	A	Check if the paper detector is connected properly.	Connect the connector properly if it is disconnected.
		(4) Printer detector is damaged.	B	Check the paper detector function with an oscilloscope.	Replace the paper detector if it is damaged.
		(5) Printer FFC is disconnected.	A	Check if the printer FFC is connected properly.	Connect the FFC if it is disconnected.

Table 5-1 Troubleshooting

Phenomenon	Condition	Cause	Level	Where/how to check	Procedure
PAPER LED is flashing.	Self test standby state	Self test is in the standby state	A	Check if the self test printing is completed.	Press paper feeding SW on the control circuit board to complete the self test when not completed.
ERROR LED is flashing. (For the LED flashing patterns, see "Error LED" on page 3-12.)	Print head high temperature error	The head temperature has reached at 75°C or more.	A	–	– (When the head is cooled down to 70°C or less, the unit will recover automatically.)
ERROR LED is flashing (For the LED flashing patterns, see "Error LED" on page 3-12.)	Platen open error	The platen is open.	A	Check if the platen is not open.	Close the platen when it is open.
	Platen open is not detected.	The platen open detector is damaged.	B	Check the platen open detector function with an oscilloscope.	Replace the detector if it is damaged.
	Autocutter error	(1)Paper chips or foreign matter is inside the autocutter and has locked it.	B	Check whether paper chips or foreign matter is jammed inside the autocutter.	After turning off the power, remove paper chips or foreign matter; then turn on the power.
		(2)The internal function of the autocutter is damaged.	B	Check the power supply voltage.	Replace the autocutter if the power supply voltage is normal.
	Black mark detection error	(1)No black mark is printed.	A	Check if the paper is printed with a black mark.	Replace with the black mark printed paper.
		(2)The wrong side of the paper is used.	A	Check if the correct side of the paper is used.	Replace with the paper with the black mark on the correct side.
		(3)The black mark detector is damaged.	B	Check the black mark detector function with an oscilloscope.	Replace the detector if it is damaged.
		(4)Paper chips or foreign matter is jammed around the black mark detector.	A	Check whether paper chips or foreign matter is jammed around the black mark detector.	Remove the paper chips or foreign matter if there is any.

Table 5-1 Troubleshooting

Phenomenon	Condition	Cause	Level	Where/how to check	Procedure
Printing operation does not work.	Nothing is printed.	(1) The head FFC connection failure	A	Check whether the head FFC is connected properly.	Connect the head FFC properly.
		(2)The head FFC signal line is broken.	A	See or check with an oscilloscope whether there is damage or break of the head FFC.	Replace the head FFC if it is broken.
		(3)Head input pulse failure	B	Check with an oscilloscope whether the input pulse is within the specified range.	If the input pulse is abnormal, replace the control circuit module.
		(4)Head failure (Dr.IC, etc.)	B		If the input pulse is normal, replace the thermal head.
	Dots are missing continuously.	(1)Foreign matter is attached to the head heating elements	A	See if anything is wrong with the head heating elements	Clean the head heating elements if foreign matter attached.
		(2)The head heating elements are damaged.	A		Replace the thermal elements
		(3)Head failure (Dr.IC, etc.)	B	Check with an oscilloscope if the input pulse is within the specified range.	If the input pulse is normal, replace the thermal head.
	Dots are missing occasionally.	(1)Foreign matter is on the surface of the platen.	A	Check the surface of the platen with an oscilloscope or a magnifier.	Clean the surface of the platen if foreign matter is attached to it.
		(2)The platen surface is deformed.	A		Replace the platen if there is any damage on the platen surface.

Table 5-1 Troubleshooting

Phenomenon	Condition	Cause	Level	Where/how to check	Procedure
Printing is faint.	All printing color is faint.	Printing density setting is set to light. (The color sensitivity difference depending on the paper)	B	<ul style="list-style-type: none"> •Check the printing density setting of the control circuit module. •Check if the specified paper is used. 	Change the setting of the printing density to darken.
	All or some part of printing is faint.	(1)Dirt or foreign matter attaches to the head heating elements.	A	See or check the head heating elements with a magnifier.	Clean the head heating elements if foreign matter is attached to the elements.
		(2)Thermal sensitivity has deteriorated due to paper deterioration	A	Check whether the paper has deteriorated.	Replace the deteriorated paper.
		(3)Thermal head heating elements are defective.	B	Check the surface of the thermal head with a magnifier.	Replace the thermal head.
	Printing is partly faint.	Damage or deformation of the platen surface	A	See or check with a magnifier the platen surface.	Replace the platen if the platen surface is damaged or deformed.
Abnormal or incorrect printing	Abnormal or incorrect printing	(1)Thermal head input pulse failure	B	Check with an oscilloscope if the input pulse is within the specified range.	If the input pulse is abnormal, replace the control circuit board.
		(2)Thermal head failure (Dr.IC, etc.)	B		If input pulse is normal, replace the thermal head.
Paper cannot be inserted.	Paper cannot be inserted into the printer module.	(1)Paper chips or foreign matter is in the paper guide of the printer module.	A	Check whether paper chips or foreign matter is inside the paper guide.	Remove paper chips or foreign matter if there is any.
		(2)Paper detector on the paper guide of the printer module is defective.	B	Check if the detector operates properly.	<ul style="list-style-type: none"> •Remove paper chip or foreign matter if there is any. •Replace the detector if it is damaged.
		(3)The shape of the paper edge is not like the specified one.	A	Check if the paper edge is cut properly.	Cut the paper edge properly.

Table 5-1 Troubleshooting

Phenomenon	Condition	Cause	Level	Where/how to check	Procedure
Paper is not fed.	Paper is not fed smoothly.	(1)The paper roll supply module does not oscillate properly.	B	Check if the paper is pulled out smoothly. (The paper tension loading should be less than the rating value.)	<ul style="list-style-type: none"> •Load the paper properly. •Replace the paper roll supply module if the oscillation loading of the paper supply module is excessive.
		(2) The paper size is not correct.	A	Check the paper diameter, width, and thickness.	Use the specified paper.
	Paper is not fed.	(1)Abnormal input signal or paper feed motor failure	B	Check the power supply voltage, input signal, and operation of each paper feed motor.	<ul style="list-style-type: none"> •Replace the control circuit board module if there is any problem with the power supply voltage, input signal. •Replace the motor if there is any problem with the motor operation.
		(2)The paper feed connector is disconnected.	A	Check if each paper feed motor is connected properly.	Connect the connector properly.
		(3)Power transmission parts (gears) are damaged, or foreign matter is caught between gears.	B	<ul style="list-style-type: none"> •Check the power transmission state of each gears. •Check if no foreign matter is caught between gears. 	<ul style="list-style-type: none"> •Replace damaged gears. •Remove foreign matter if there is any.
Paper feeding pitch is defective.	The character spacing is not uniform.	(1)The paper roll supply module does not oscillate properly.	B	Check if the paper is pulled out smoothly. (The paper tension loading should be less than the rating value.)	<ul style="list-style-type: none"> •Load the paper properly. •Replace the paper roll supply module if the oscillation load of the paper supply module is excessive.
		(2)Power transmission parts (gears) are damaged, or foreign matter is caught between gears.	B	<ul style="list-style-type: none"> •Check the power transmission state of each gear. •Check if no foreign matter is caught between gears. 	<ul style="list-style-type: none"> •Remove foreign matter if there is any. •Replace damaged gears .

Table 5-1 Troubleshooting

Phenomenon	Condition	Cause	Level	Where/how to check	Procedure
Paper feeding pitch is defective.	The character spacing is not uniform.	(3)Abnormal input signal or paper feed motor failure	B	Check the power supply voltage, input signal, and operation of each paper feed motor.	<ul style="list-style-type: none"> •Replace the control circuit board module if there is any problem with the power supply voltage, input signal. •Replace the motor if there is any problem with the motor operation.
		(4)Paper feed slip due to the platen wear and paper powder	B	Check the friction force of the platen surface.	<ul style="list-style-type: none"> •Clean the platen if paper powder accumulates on it. •Replace the platen if it is worn out.
Paper cannot be cut.	Paper is not cut automatically.	(1)Foreign matter inside the autocutter	A	Check whether foreign matter is inside the autocutter.	Remove foreign matter if there is any.
		(2)Abnormal input signal or inner mechanism damage of the autocutter	B	Check the power supply voltage, input signal, and operation of the cutter motor.	<ul style="list-style-type: none"> •Replace the control circuit board module if there is any problem with the power supply voltage, input signal. •Replace the motor if there is any problem with the autocutting operation.
Platen unit can not open/ close.	Platen unit does not open.	The cutter blade is not in the home position.	B	Check if the cutter blade is in the home position.	Turn the knob to return the cutter blade to the home position.
	Platen unit does not close.	Foreign matter inside the printer.	A	Check whether foreign matter is inside the printer.	Remove foreign matter if there is any.

*Chapter 6***Assembly and Disassembly****Small Parts Abbreviation**

All small parts are represented by the abbreviations listed below

Table 6-1 Small Parts Abbreviations

記号	部品名称
R.E	Retaining ring E-type
C-ring	Crescent ring
C.B. (M2 × 2.5)	Cross-recessed binding head machine screw, 2 × 2.5, F/Zn
C.B. (M2 × 3)	Cross-recessed binding head machine screw, 2 × 3, F/Zn
C.B. (M2.3 × 3)	Cross-recessed binding head machine screw, 2.3 × 3, F/Zn
C.B. (M2.5 × 4)	Cross-recessed binding head machine screw, 2.5 × 4, F/Zn
C.B. (M3 × 4)	Cross-recessed binding head machine screw, 3 × 4, F/Zn
C.B. (M3 × 6)	Cross-recessed binding head machine screw, 3 × 6, F/Zn
C.B. (M3 × 8)	Cross-recessed binding head machine screw, 3 × 8, F/Zn
C.B. (M4 × 16)	Cross-recessed binding head machine screw, 4 × 16, F/Zn
C.B.B-tite (M2 × 6)	Cross-recessed binding head B-tite self tapping screw, 2 × 6, F/Zn
C.B.P-tite (M3 × 8)	Cross-recessed binding head P-tite self tapping screw, 3 × 8, F/Zn
C.B.S-tite (M2.5 × 4)	Cross-recessed binding head S-tite self tapping screw, 2.5 × 4, F/Zn
C.B.S-tite (M3 × 5)	Cross-recessed binding head S-tite self tapping screw, 3 × 5, F/Zn
C.B.S-tite (M3 × 12)	Cross-recessed binding head S-tite self tapping screw, 3 × 12, F/Zn
C.C.P-tite (M2.5 × 6)	Cross-recessed cup head P-tite self tapping screw, 2.5 × 6, F/Zn
C.F. (M3 × 8)	Cross-recessed flat head screw, 3 × 8, F/Zn
C.P-tite F screw (M2 × 3)	Cross-recessed 3P-tite self tapping screw F, 2 × 3, F/Ni
C.P (P2)	Cross-recessed pan head screw, 3 × 6, F/Zn
C.P (S-P1) (M1.6 × 5)	Cross-recessed pan head screw with S.W.+P.W.1, 1.6 × 5, F/Zn
C.P. (M2 × 2)	Cross-recessed pan head screw-3, 2 × 2, F/Ni
C.P. (M2 × 6)	Cross-recessed pan head machine screw, 2 × 6, F/Zn
H. nut (3)	Hexagonal nut double chamfered, 3, F/Zn
H. nut (4)	Hexagonal nut double chamfered, 4, F/Zn
P. washer (4.3 × 0.8 × 8)	Plain washer (4.3 × 0.8 × 8)
P. washer (3 × 0.5 × 7)	Plain washer (3 × 0.5 × 7)
P. washer (3.7 × 0.5 × 8)	Plain washer (3.7 × 0.5 × 8)
Conical S. washer-1L, 4	Conical spring washer, Class 1, light load, 4, S/Na
S. washer-2, 4	Spring washer No.2, 4, F/Zn

Disassembly

- ❑ For disassembly, follow the assembly procedures described in “Assembly” in reverse sequence.
- ❑ Disassembly of the modules beyond the level show in the exploded diagrams at the end of this manual may result in damage to the modules and their functions.

Assembly

- ❑ The assembly process is divided into pre-assembly and main assembly. First perform the pre-assembly; then proceed to the main assembly after the components have been assembled into units.
- ❑ Perform assembly while referring to the component shapes and mounting positions shown in the exploded diagrams at the end of this manual.
- ❑ The ★ symbols in the “Reassembly step” indicate places where checks are required. Make sure to follow the instructions given in these places.
- ❑ Circled numbers in the “Reassembly step” indicate that lubrication is required during the reassembly of that component and that such lubrication will be difficult unless performed during reassembly.
- ❑ Refer to “Lubrication” in Chapter 4 for lubrication details on the printer module and other modules. Also, see the lubrication diagrams at the end of this manual for the places to lubricate.

In this assembly section, assembly steps are described as the following sequence:

- ❑ Installation of the printer module (Pre-assembly A to F and Main Assembly A to L {page 3 to 29})
- ❑ Installation of the other modules (Pre-assembly A to H and Main Assembly A to E {page 30 to 57})

The Main assembly A to E in the other modules’ assembly is the assembly for the all pre-assembled modules including the printer module.

Installation of the Printer Module

Pre-assembly A: Paper guide, straight, back unit

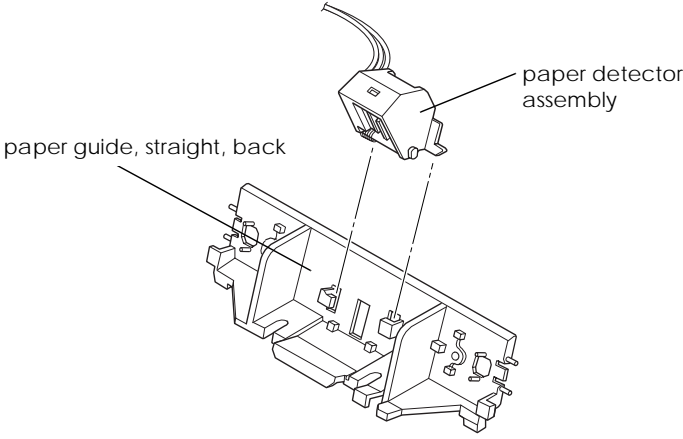
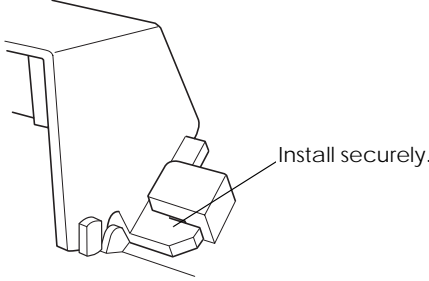
Reassembly step	Part name	Assembly procedure
1	Paper detector assembly	
2	Paper guide, straight, back	<input type="checkbox"/> Slide the paper detector assembly onto the paper guide, straight, back .
★		 <p data-bbox="694 705 981 750">paper guide, straight, back</p> <p data-bbox="1212 638 1380 694">paper detector assembly</p> <p data-bbox="662 1052 758 1086"><Check></p> <input type="checkbox"/> Make sure that the paper detector assembly is installed securely, as shown below.  <p data-bbox="1149 1299 1308 1332">Install securely.</p>

Pre-assembly B: Frame, platen, straight unit, B

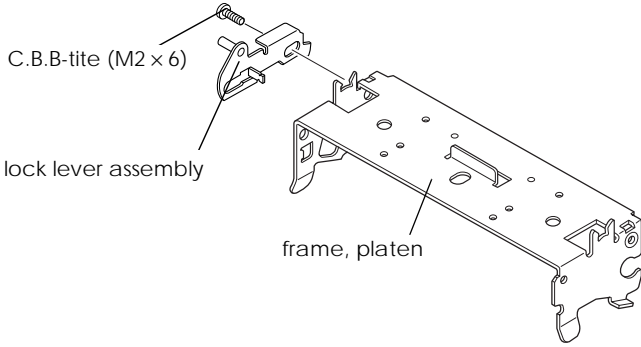
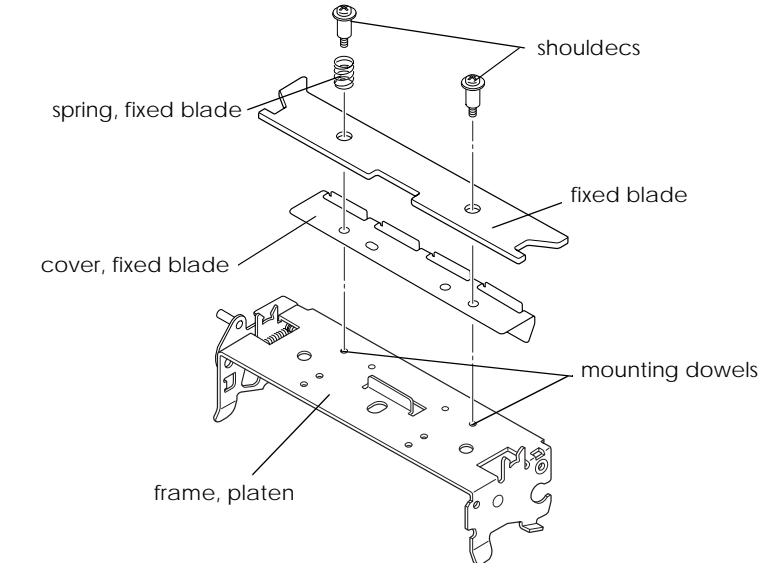
Reassembly step	Part name	Assembly procedure
1	Frame, platen	
2	Lock lever assembly C.B.B-tite (M2 x 6) × 1	<input type="checkbox"/> Install the lock lever assembly on the frame, platen , and secure it with a screw.
★		 <p>C.B.B-tite (M2 x 6)</p> <p>lock lever assembly</p> <p>frame, platen</p> <p><Check></p> <input type="checkbox"/> Tightening torque: 294 to 343 mN•m {3.0 to 3.5 kg•cm} <input type="checkbox"/> Make sure that the screw does not skew during tightening.
3	Cover, fixed blade	
4	Fixed blade	<input type="checkbox"/> Install the cover, fixed blade and the fixed blade on the frame, platen ; then secure them with shouldecs .
5	Spring, fixed blade Shouldec (2 x 6 x 2) × 2	At this time, install the spring, fixed blade on one of the shouldecs , as shown below.
★		 <p>shouldecs</p> <p>spring, fixed blade</p> <p>fixed blade</p> <p>cover, fixed blade</p> <p>mounting dowels</p> <p>frame, platen</p> <p><Check></p> <input type="checkbox"/> Tightening torque: 177 to 226 mN•m {1.8 to 2.3 kg•cm} <input type="checkbox"/> Make sure to install the fixed blade right-side-up. <input type="checkbox"/> Make sure that the dowels on the frame, platen fit securely into the holes on the cover, fixed blade . <input type="checkbox"/> Make sure to install the spring, fixed blade in the correct position.

Pre-assembly B

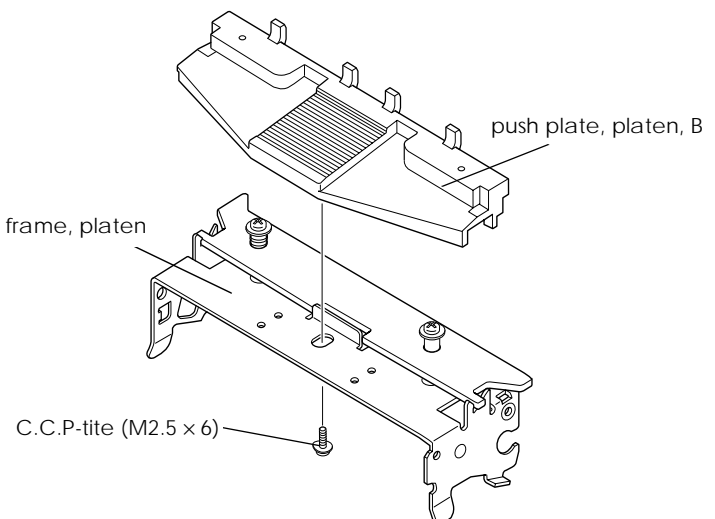
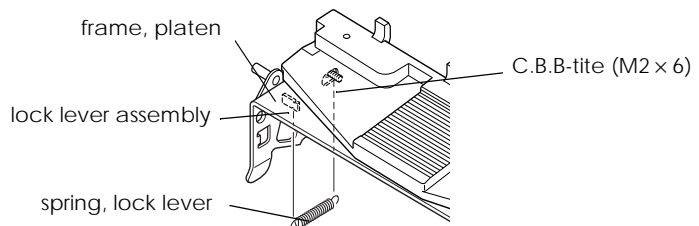
Reassembly step	Part name	Assembly procedure
6	Push plate, platen, B C.C.P-tite (M2.5 x 6) × 1	<p><input type="checkbox"/> Install the push plate, platen, B to the frame, platen and secure it with a screw.</p>  <p>The diagram illustrates the assembly of the push plate, platen, B onto the frame, platen. A C.C.P-tite (M2.5 x 6) screw is used to secure the push plate to the frame. Labels include: push plate, platen, B; frame, platen; and C.C.P-tite (M2.5 x 6).</p>
★		<p><Check></p>
7	Spring, lock lever	<p><input type="checkbox"/> Tightening torque: 490 to 539 mN•m {5.0 to 5.5 kg•cm}</p> <p><input type="checkbox"/> Hook the ends of the spring, lock lever onto the lock lever assembly and C.B.B-tite (M2 x 6) from the inside of the frame, platen.</p>  <p>The diagram illustrates the assembly of the spring, lock lever onto the lock lever assembly and C.B.B-tite (M2 x 6) from the inside of the frame, platen. Labels include: frame, platen; lock lever assembly; spring, lock lever; and C.B.B-tite (M2 x 6).</p> <p>★</p> <p><Check></p> <p><input type="checkbox"/> Make sure that the spring, lock lever is hooked securely.</p>

Pre-assembly B

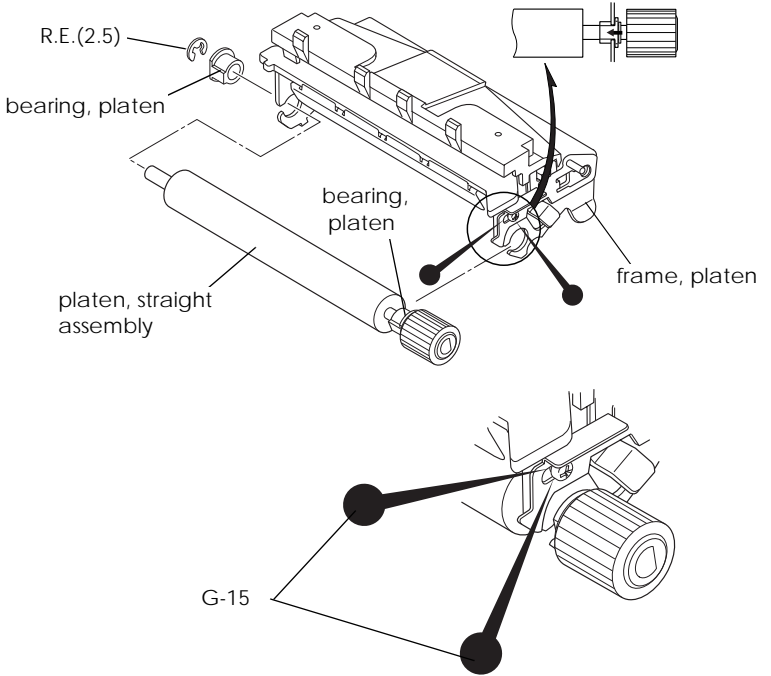
Reassembly step	Part name	Assembly procedure
8	Platen, straight assembly	
9	Bearing, platen R.E. (2.5) × 1	<ul style="list-style-type: none"> ❑ After installing the platen, straight assembly to the frame, platen, install the bearing, platen from the outside of the frame, platen; then secure it with an R.E. ❑ Lubricate with G-15 two points where the screw on the lock lever assembly is secured.
⑩		

Pre-assembly C: Cutter motor assembly

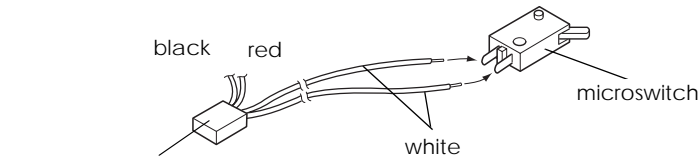
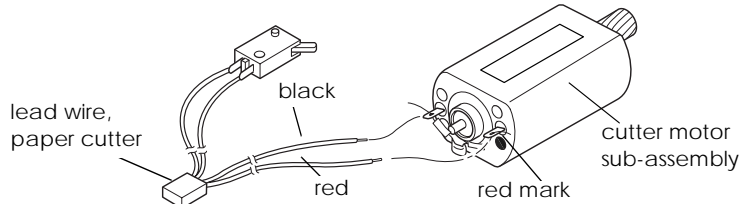
Reassembly step	Part name	Assembly procedure
1	Microswitch	
2	Lead wire, paper cutter	<p><input type="checkbox"/> Solder the white lead wire of the lead wire, paper cutter to the microswitch.</p>  <p style="text-align: right;">*No polarity</p>
3	Cutter motor sub-assembly	<p><input type="checkbox"/> Solder the red wire of the lead wire, paper cutter to the red marked terminal side of the cutter motor sub-assembly, and solder the black lead wire to the other terminal.</p> 
★		<p><Check></p> <p><input type="checkbox"/> Make sure to arrange the lead wires properly.</p>

Pre-assembly D: Cutter, cover sub-unit

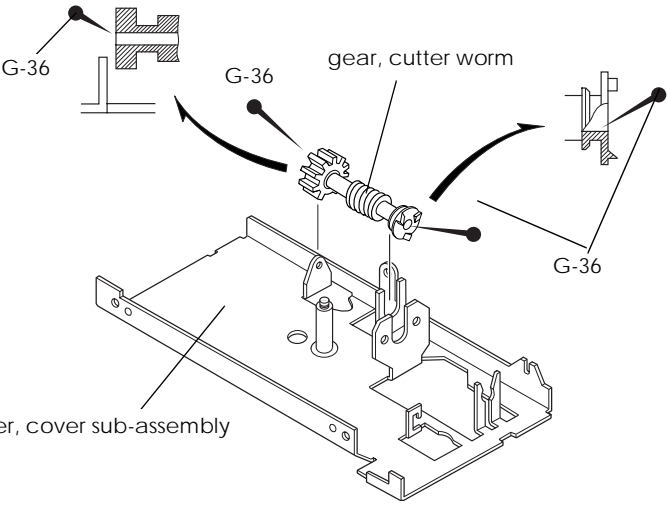
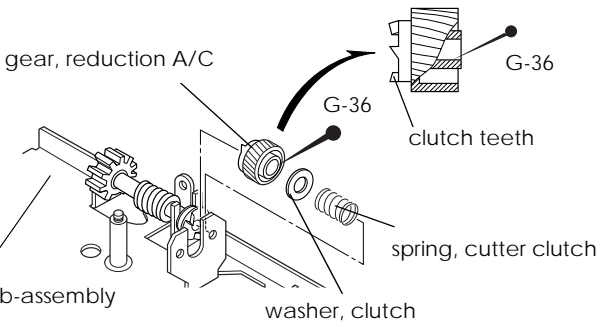
Reassembly step	Part name	Assembly procedure
1	Cutter, cover sub-assembly Gear, cutter worm	<p>☐ Lubricate with G-36 the bore of the gear, cutter worm and the point where the gear, cutter worm comes in contact the cutter, cover sub-assembly; then install it on the cutter, cover sub-assembly.</p>  <p>The diagram illustrates the assembly of the gear, cutter worm onto the cutter, cover sub-assembly. It shows the gear, cutter worm being inserted into the sub-assembly. Lubrication points are indicated with G-36.</p>
4	Gear, reduction A/C Washer, clutch	
5	Spring, cutter clutch	<p>☐ After lubricating the bore of the gear, reduction A/C with G-36, attach the washer, clutch and the spring, cutter clutch to the gear, reduction A/C; then, install it to the cutter cover sub-assembly.</p>  <p>The diagram illustrates the assembly of the gear, reduction A/C, washer, clutch, and spring, cutter clutch onto the cutter, cover sub-assembly. It shows the gear, reduction A/C being attached to the sub-assembly. Lubrication points are indicated with G-36.</p>
★		<p><Check></p> <p>☐ Make sure not to damage the clutch teeth when installing the gear, reduction A/C.</p>

Pre-assembly D

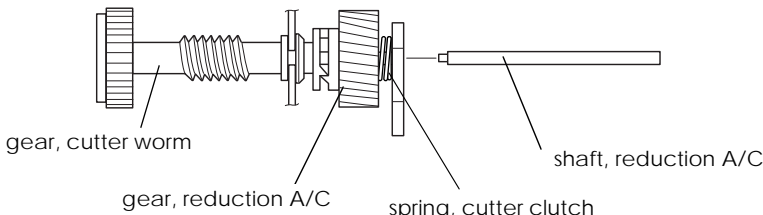
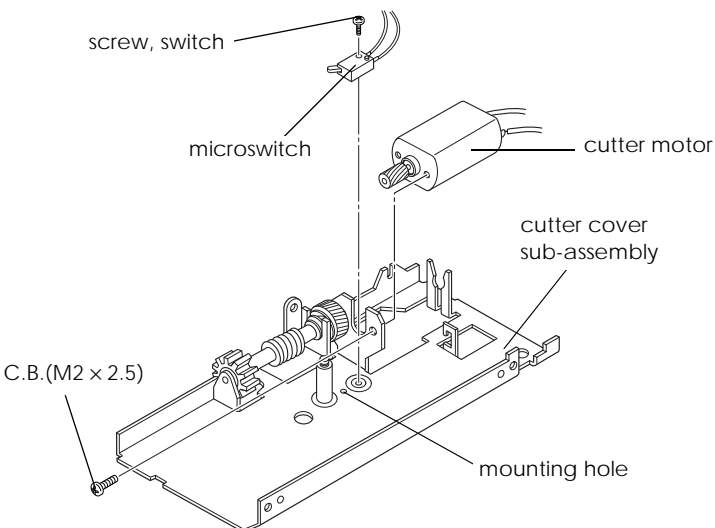
Reassembly step	Part name	Assembly procedure
6	Shaft, reduction A/C	<p><input type="checkbox"/> Insert the shaft, reduction A/C to the bores of the gear, reduction A/C and the gear, cutter worm.</p> 
★		<p><Check></p> <p><input type="checkbox"/> Make sure that the shaft, reduction A/C is oriented properly before insertion.</p>
7	Cutter, motor assembly C.B.(M2 x 2.5) × 1 Screw, switch	<p><input type="checkbox"/> Install the cutter, motor to the cutter cover sub-assembly, and secure it with the C.B.(M2 x 2.5).</p> <p><input type="checkbox"/> Install the microswitch to the cutter cover sub-assembly, and secure it with the screw, switch.</p> 
★		<p><Check></p> <p><input type="checkbox"/> Tightening torque: 245 to 294 mN•m {2.5 to 3.0 kg•cm} (C.B.(M2 x 2.5))</p> <p><input type="checkbox"/> Tightening torque: 108 to 147 mN•m {1.1 to 1.5 kg•cm} (screw, switch)</p> <p><input type="checkbox"/> Make sure to install the cutter, motor with the labeled side down.</p> <p><input type="checkbox"/> Make sure that the cutter, motor is installed securely.</p> <p><input type="checkbox"/> Make sure that the dowel on the microswitch fits securely in the mounting hole on the cutter cover sub-assembly.</p>

Pre-assembly D

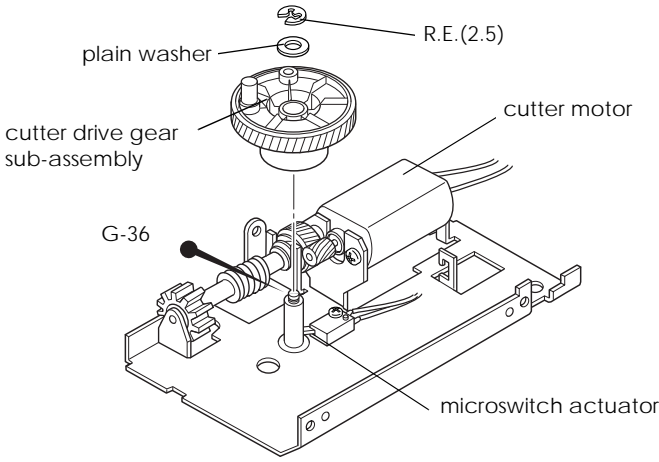
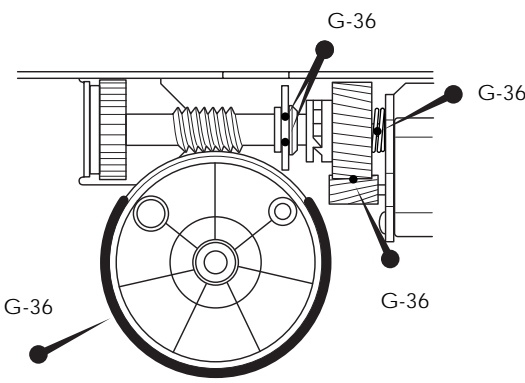
Reassembly step	Part name	Assembly procedure
<p>⑧</p> <p>★</p>	<p>Cutter drive gear sub-assembly Plain washer (3 x 0.5 x 7) × 1 R.E. (2.5) × 1</p>	<p><input type="checkbox"/> After lubricating the shaft on the cutter cover sub-assembly with G-36, install the cutter drive gear sub-assembly and the plain washer on the shaft; then secure them with an R.E.</p>  <p><Check></p> <ul style="list-style-type: none"> <input type="checkbox"/> Make sure not to apply excessive pressure to the microswitch actuator when installing the cutter drive gear sub-assembly. <input type="checkbox"/> Make sure not to damage the cutter drive gear sub-assembly when securing it with the R.E. <input type="checkbox"/> Lubricate the specified areas with G-36. 

Pre-assembly E: Cutter unit, B

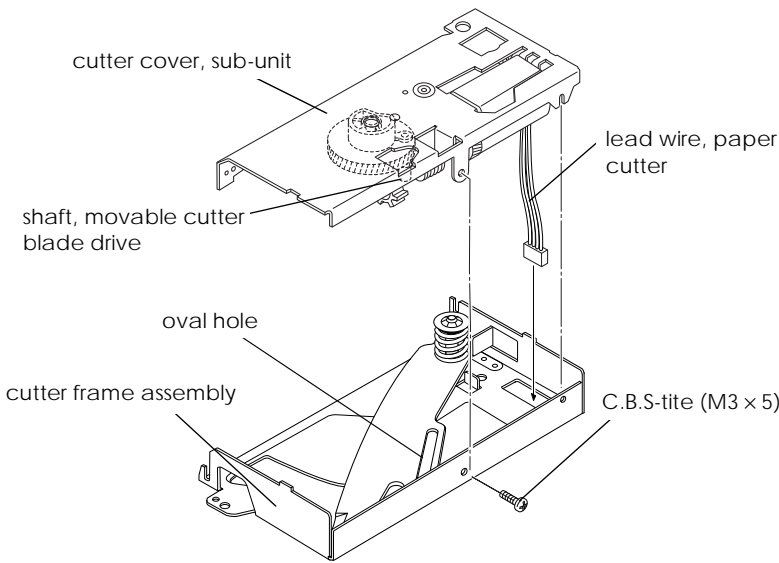
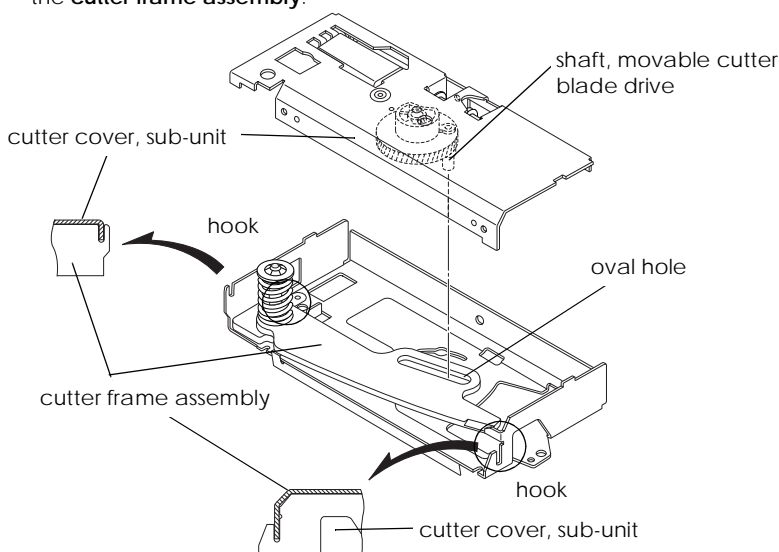
Reassembly step	Part name	Assembly procedure
<p>1</p> <p>2</p> <p>★</p>	<p>Cutter cover sub-unit</p> <p>Cutter frame assembly C.B.S-tite (M3 x 5) × 1</p>	<p>□ Pass the lead wire, paper cutter through the hole on the cutter frame assembly and secure the cutter cover sub-unit and the cutter frame assembly with a screw.</p> <p>□ When putting the cutter cover sub-unit and the cutter frame assembly together, insert the shaft, movable cutter blade drive into the oval hole on the movable cutter blade.</p>  <p><Check></p> <p>□ Tightening torque: 834 to 932 mN•m {8.5 to 9.5 kg•cm}</p> <p>□ Make sure that the shaft, movable cutter blade drive fits securely into the oval hole on the movable cutter blade.</p> <p>□ Make sure that the edges of the cutter cover sub-unit fit into the hooks on the cutter frame assembly.</p> 

Pre-assembly E

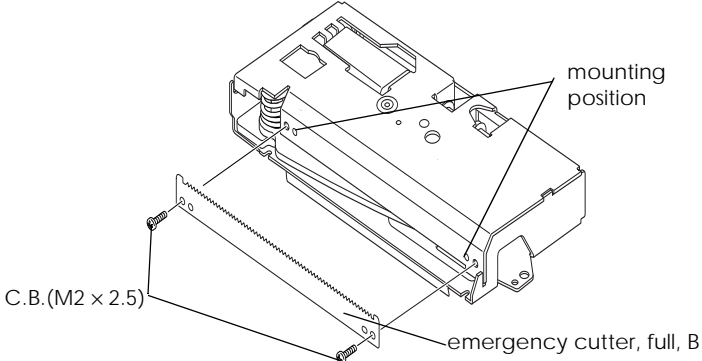
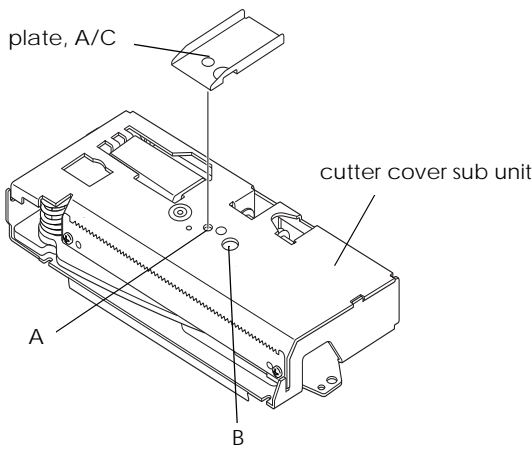
Reassembly step	Part name	Assembly procedure
3	Emergency cutter, full, B C.B.(M2 x 2.5) × 2	<p><input type="checkbox"/> Install the emergency cutter, full, B to the cutter cover sub-unit with screws.</p>  <p><Check></p> <ul style="list-style-type: none"> <input type="checkbox"/> Tightening torque: 98 to 147 mN•m {1.0 to 1.5 kg•cm} <input type="checkbox"/> Make sure that the dowels on the cutter cover sub-unit is fitted in the holes on the emergency cutter, full, B.
★ 4	Plate, A/C assembly	<ul style="list-style-type: none"> <input type="checkbox"/> Peel the backing off of a couple-face tape. <input type="checkbox"/> Hook the bent part of the plate, A/C to the edge of the cover, cutter. <input type="checkbox"/> Align parts A and B with the holes on the plate, A/C as shown below, and stick the plate to the cutter cover sub-unit. 

Pre-assembly F: Black mark detector sub-assembly (option)

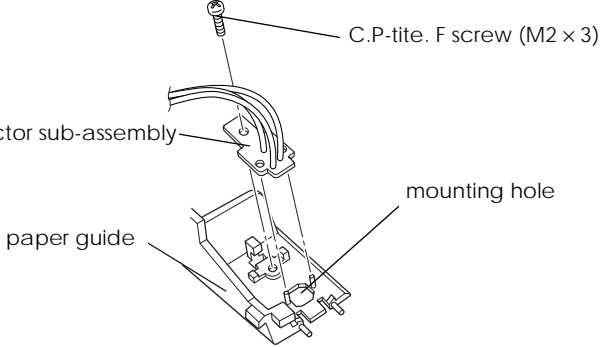
Reassembly step	Part name	Assembly procedure
1	Black mark (B.M.) sub-assembly	
2	Paper guide C.P-tite F screw (M2 x 3) × 1	<p><input type="checkbox"/> Install the B.M. detector sub-assembly in one of the two detector mounting holes on the paper guide, and secure it with a screw. Both the straight path and the curved path types can be installed this way.</p>  <p style="text-align: right;">C.P-tite. F screw (M2 x 3)</p> <p>B.M. detector sub-assembly</p> <p style="text-align: right;">mounting hole</p> <p>paper guide</p>
★		<p><Check></p> <p><input type="checkbox"/> Tightening torque: 167 to 186 mN•m {1.7 to 1.9 kg•cm}</p> <p><input type="checkbox"/> Make sure that the detector fits securely into the detector mounting hole on the paper guide.</p>

Main Assembly A: Motor, paper feed, receipt, B and Platen detector

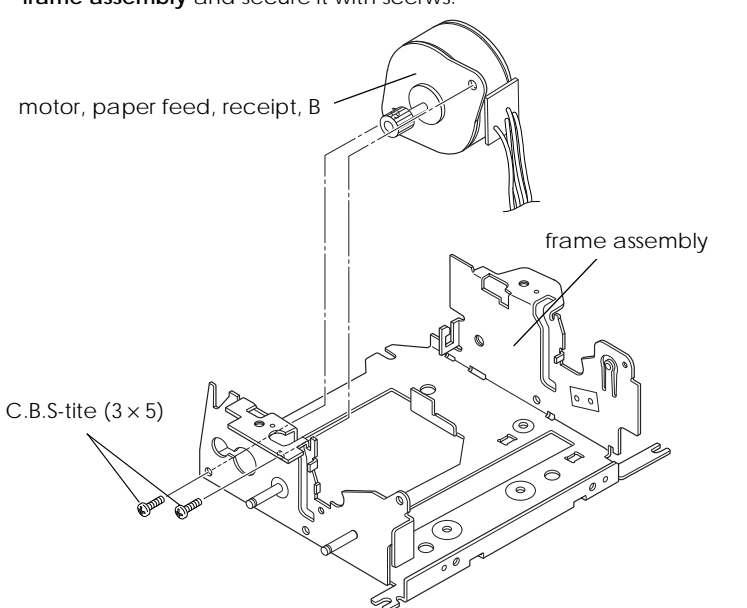
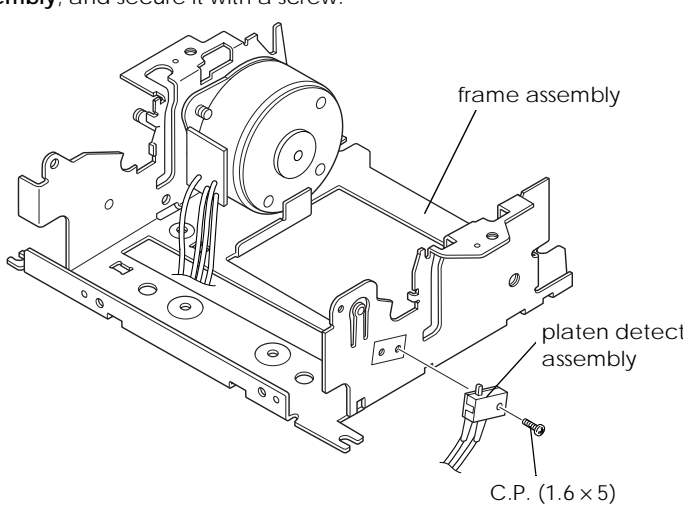
Reassembly step	Part name	Assembly procedure
1	Frame assembly	
2	Motor, paper feed, receipt, B C.B.S-tite (3 x 5) × 2	<p>□ Align the motor, paper feed, receipt, B with the mounting position on the frame assembly and secure it with screws.</p>  <p>motor, paper feed, receipt, B</p> <p>frame assembly</p> <p>C.B.S-tite (3 x 5)</p> <p>★</p> <p><Check></p> <p>□ Tightening torque: 834 to 932 mN•m {8.5 to 9.5 kg•cm}</p> <p>□ Make sure that the motor, paper feed, receipt, B is oriented properly.</p>
3	Platen detector assembly C.P. (1.6 x 5) × 1	<p>□ Align the platen detector assembly to the mounting position on the frame assembly, and secure it with a screw.</p>  <p>frame assembly</p> <p>platen detector assembly</p> <p>C.P. (1.6 x 5)</p>

Main Assembly A

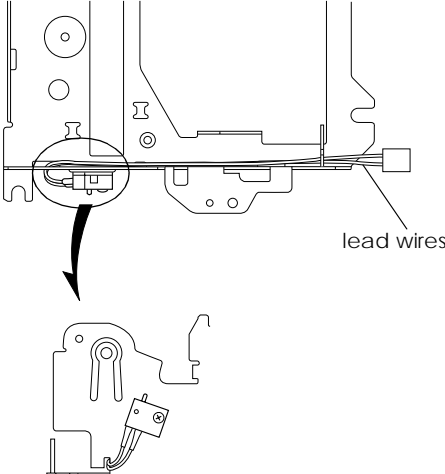
Reassembly step	Part name	Assembly procedure
★		<p><Check></p> <ul style="list-style-type: none"><input type="checkbox"/> Tightening torque: 147 to 196 mN•m {1.5 to 2.0 kg•cm}<input type="checkbox"/> After installing the platen detector assembly, arrange the lead wires.  <p>lead wires</p>

Main Assembly B: Paper guide, straight, front and Paper guide, straight, back unit

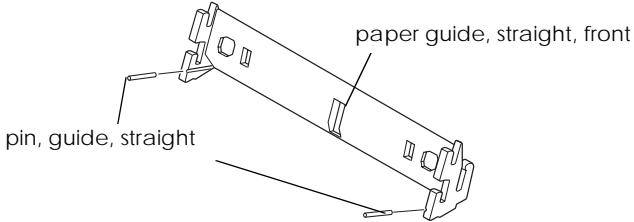
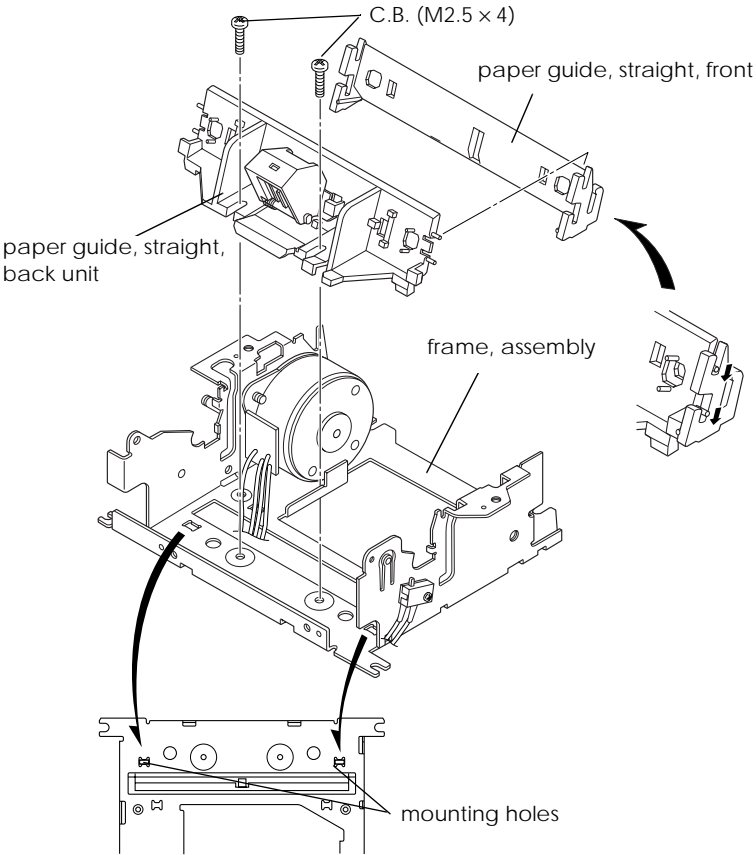
Reassembly step	Part name	Assembly procedure
1	Paper guide, straight, front	
2	Pin, guide, straight × 2	<p>□ Insert the pin, guide, straight into the holes on the paper guide, straight, front.</p> 
3	<p>Paper guide, straight, back unit C.B. (2.5 × 4) × 2</p>	<p>□ After putting the paper guide, straight, front and the paper guide, straight, back unit together, install them to the mounting holes on the frame assembly and secure them with screws.</p> 

Main Assembly B

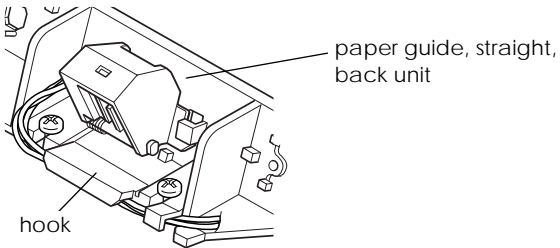
Reassembly step	Part name	Assembly procedure
★		<p><Check></p> <ul style="list-style-type: none">❑ Tightening torque: 441 to 490 mN•m {4.5 to 5.0 kg•cm}❑ The dowels on the paper guide, straight, back unit fit securely into the holes on the frame assembly.❑ Make sure that the lead wires of the paper detector assembly are not caught between the frame assembly and the paper guide, straight, back unit.❑ Make sure that the wires of the paper detector assembly are passed under the hook on the paper guide, straight, back unit. 

Main Assembly C: Frame, platen, straight unit

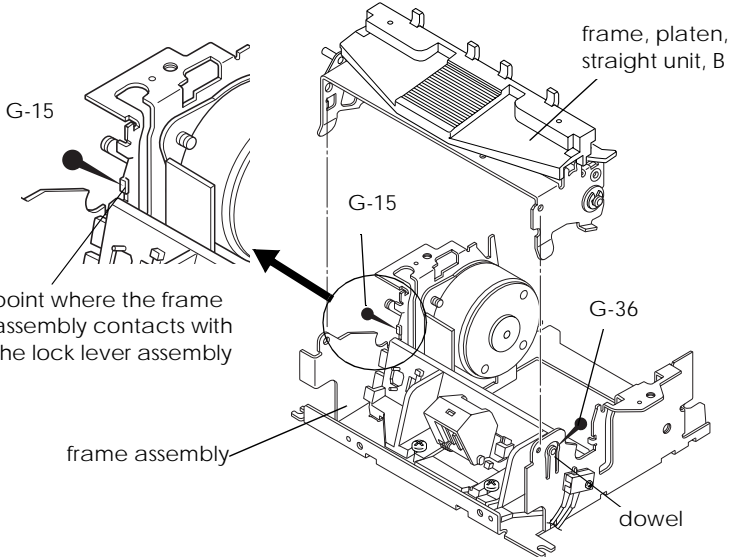
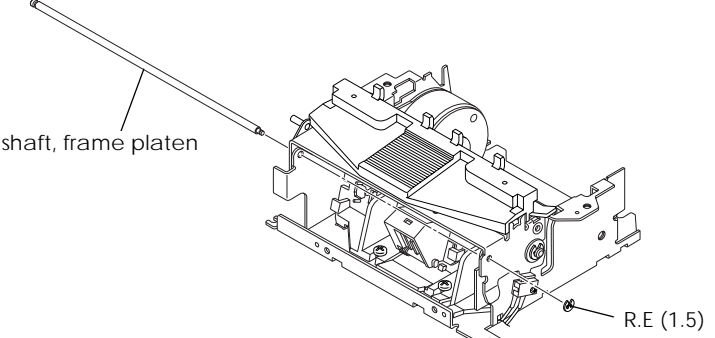
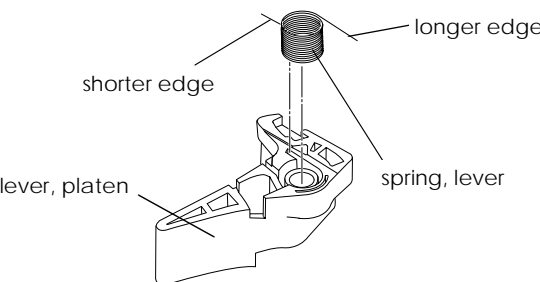
Reassembly step	Part name	Assembly procedure
①		<ul style="list-style-type: none"> ❑ Lubricate the dowel on the frame assembly with G-36.
②		<ul style="list-style-type: none"> ❑ Lubricate the point where the frame assembly contacts with the lock lever assembly with G-15.
3	Frame, platen, straight unit, B	<ul style="list-style-type: none"> ❑ Install the frame, platen, straight unit, B to the frame assembly.
		 <p>Diagram illustrating the assembly of the frame, platen, and straight unit B onto the frame assembly. The diagram shows the frame assembly with a dowel and a point where it contacts the lock lever assembly. The frame, platen, and straight unit B are being installed onto the frame assembly. Labels include G-15, G-36, frame assembly, frame, platen, straight unit, B, and dowel.</p>
4	Shaft, frame platen R.E (1.5) × 1	<ul style="list-style-type: none"> ❑ Align the holes on the frame assembly and the frame, platen, straight unit, B, and insert the shaft, frame platen into these holes; then, secure it with an R.E.
		 <p>Diagram illustrating the insertion of the shaft, frame platen into the frame assembly. The shaft, frame platen is shown being inserted into the holes of the frame assembly. The shaft is secured with an R.E. (1.5). Labels include shaft, frame platen and R.E (1.5).</p>
5	Lever, platen	<ul style="list-style-type: none"> ❑ Install the spring, lever on the lever, platen, as shown below.
6	Spring, lever	 <p>Diagram illustrating the installation of the spring, lever on the lever, platen. The spring, lever is shown being installed on the lever, platen. Labels include longer edge, shorter edge, lever, platen, and spring, lever.</p>

Main Assembly C

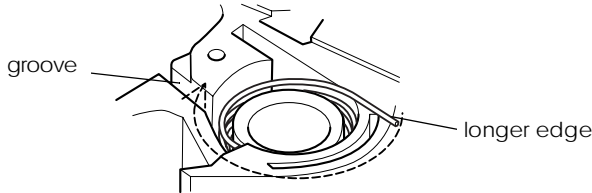
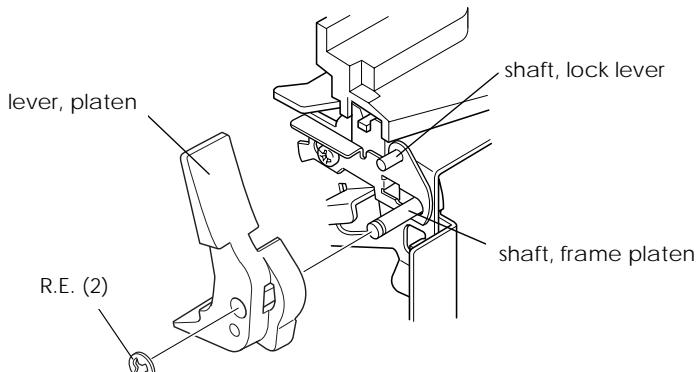
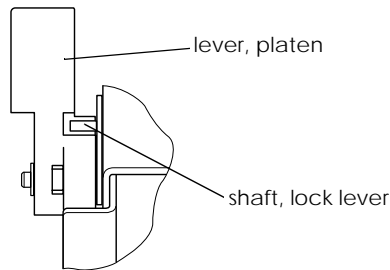
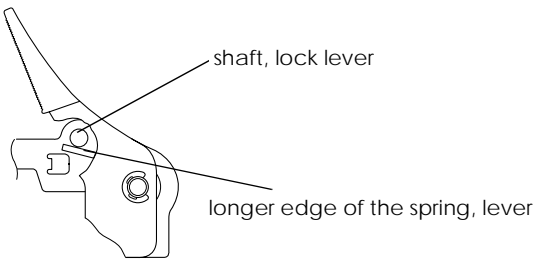
Reassembly step	Part name	Assembly procedure
★		<p><Check></p> <ul style="list-style-type: none"> <input type="checkbox"/> Hook the longer edge of the spring, lever into the groove on the lever, platen. <input type="checkbox"/> Make sure not to deform the spring, lever. 
7	R.E. (2) × 1	<ul style="list-style-type: none"> <input type="checkbox"/> Install the lever, platen to the shaft, frame platen, and secure it with an R.E.. 
★	8	<p><Check></p> <ul style="list-style-type: none"> <input type="checkbox"/> Make sure that the shaft, lock lever is placed properly into the specified position on the lever, platen.  <ul style="list-style-type: none"> <input type="checkbox"/> Remove the longer edge of the spring, lever, and hook it on the shaft, lock lever. 

Main Assembly D: Thermal print head assembly

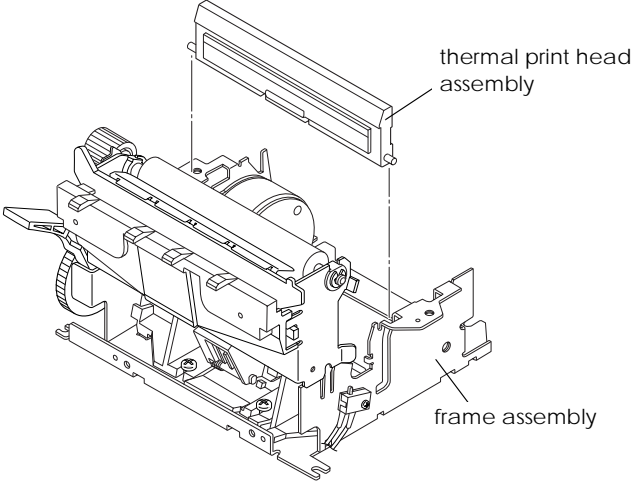
Reassembly step	Part name	Assembly procedure
1	Thermal print head assembly	<p><input type="checkbox"/> Install the thermal print head assembly in the grooves on the frame assembly.</p>  <p><Check></p> <ul style="list-style-type: none"> <input type="checkbox"/> When handling the thermal print head assembly, use proper body grounding procedures to avoid static electricity. (Use a conductive mat and wrist band during assembly.) <input type="checkbox"/> Do not touch the connector terminals and the surface of the thermal print head assembly. If foreign matter attaches to them, wipe off the foreign matter lightly, using a cotton swab dampened with alcohol.
★		

Main Assembly E: Plate, pressure spring

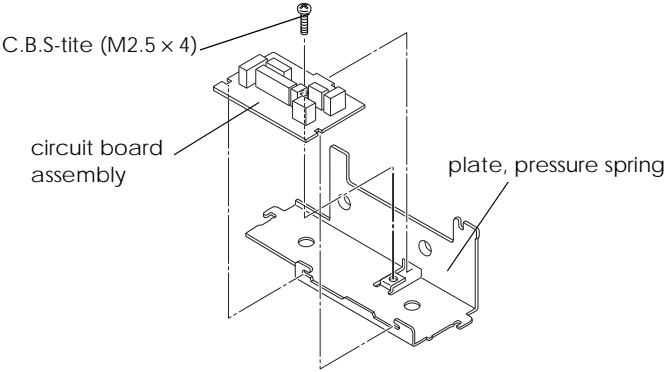
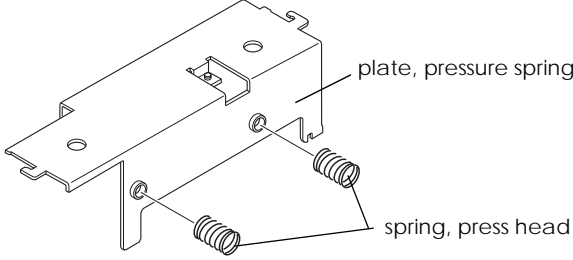
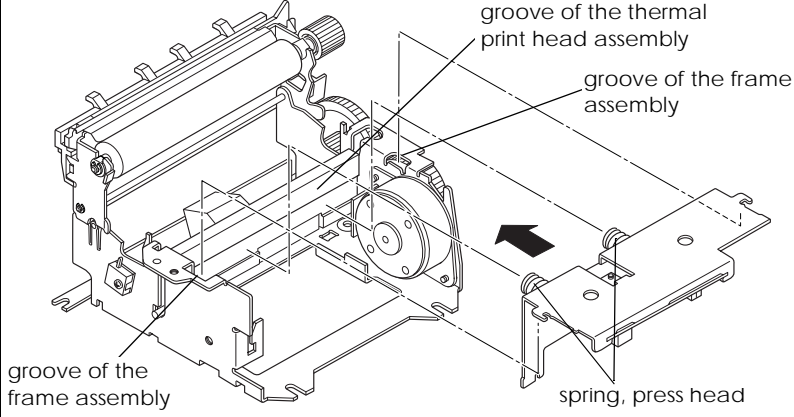
Reassembly step	Part name	Assembly procedure
1	Plate, pressure spring	
2	Circuit board assembly C.B.S-tite (M2.5 × 4) × 1	<p><input type="checkbox"/> Install the circuit board to the plate, pressure spring, and secure it with screws.</p> 
★		<p><Check></p> <p><input type="checkbox"/> Tightening torque: 608 to 657 mN•m {6.2 to 6.7 kg•cm}</p>
3	Spring, press head × 2	<p><input type="checkbox"/> Install the spring, press head to the plate, pressure spring.</p> 
★		<p><Check></p> <p><input type="checkbox"/> Make sure that the spring, press head is pushed securely into the plate, pressure spring.</p>
4		<p><input type="checkbox"/> Hook the edge of the spring, press head to the groove of the thermal print head assembly while pushing the plate, pressure spring in the arrow direction; then hook it to the groove of the frame assembly.</p> 

Main Assembly E

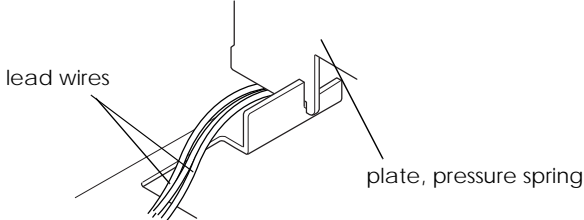
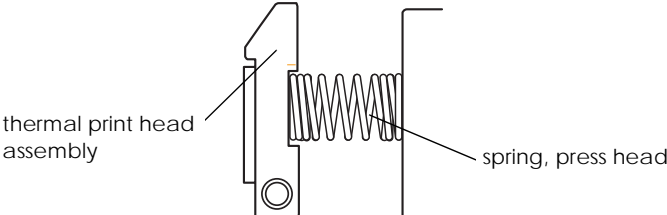
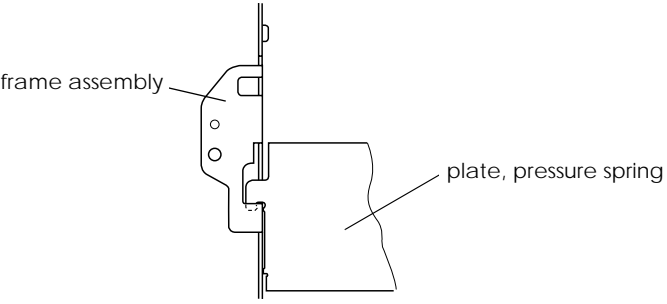
Reassembly step	Part name	Assembly procedure
★		<p><Check></p> <ul style="list-style-type: none"> ❑ Make sure that the lead wires, such as those for the paper detector assembly are not caught on anything when installing the spring, press head. ❑ Make sure that the lead wires of the paper detector assembly and the paper detector assembly are passed under the plate, pressure spring.  <ul style="list-style-type: none"> ❑ Make sure that the edge of the spring, press head fits securely into the groove on the thermal print head assembly.  <ul style="list-style-type: none"> ❑ Make sure that the plate, pressure spring is hooked securely into the hole on the frame assembly. 

Main Assembly F: Fixing plate, the Gear, reduction and Gear, idler

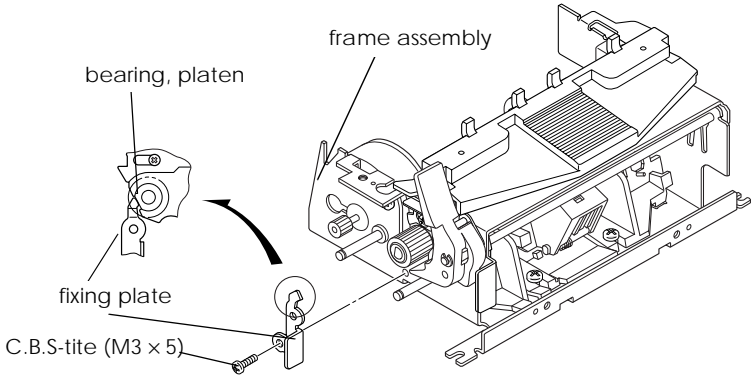
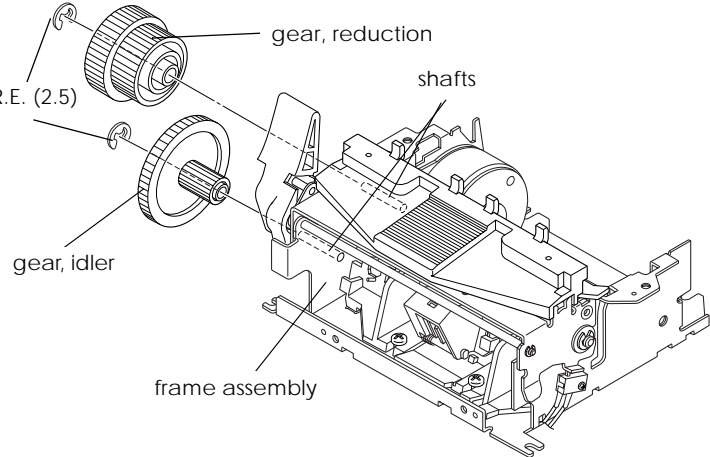
Reassembly step	Part name	Assembly procedure
1	Fixing plate C.B.S-tite (M3 x 5) × 1	<p> <input type="checkbox"/> Install the fixing plate to the frame assembly, and secure it with the screw while pushing the edge of the fixing plate to the bearing, platen. </p>  <p> <input type="checkbox"/> <Check> <input type="checkbox"/> Tightening torque: 834 to 932 mN•m {8.5 to 9.5 kg•cm} <input type="checkbox"/> Make sure that the edge of the fixing plate is pushed securely to the bearing, platen. </p>
★		
2	Gear, reduction	
3	Gear, idler R.E. (2.5) × 2	<p> <input type="checkbox"/> Install the gear, reduction and the gear, idler to the shafts on the frame assembly, and secure them with R.E.s. </p>  <p> <input type="checkbox"/> <Check> <input type="checkbox"/> Make sure not to deform the shaft on the frame assembly when securing with the R.E. </p>
★		

Main Assembly G: Cutter unit

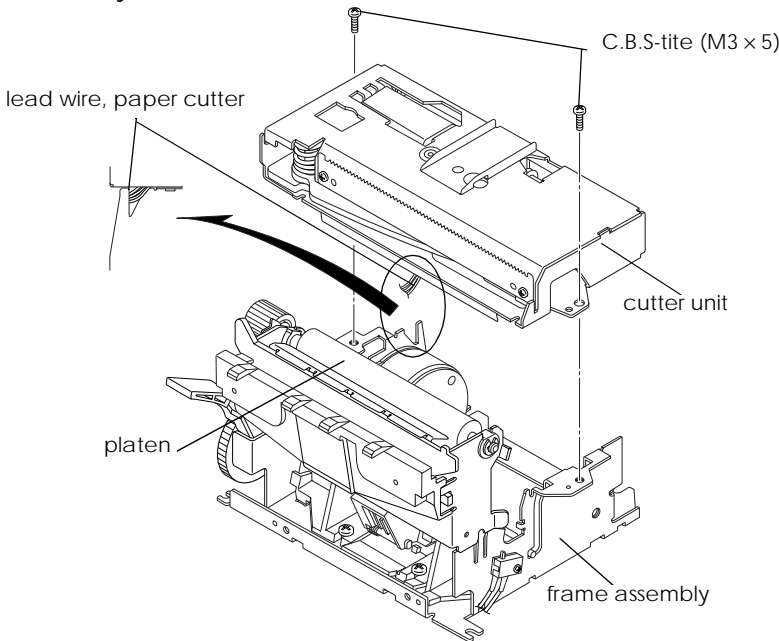
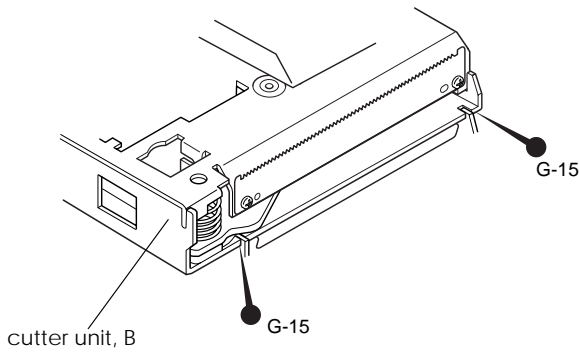
Reassembly step	Part name	Assembly procedure
<p>1</p> <p>★</p> <p>②</p>	<p>Cutter unit, B C.B.S-tite (M3 x 5) × 2</p>	<p>□ Install the cutter unit, B to the frame assembly and secure it with screws, while the lead wire, paper cutter is passed through the hook on the frame assembly.</p>  <p><Check></p> <ul style="list-style-type: none"> □ Tightening torque: 834 to 932 mN•m {8.5 to 9.5 kg•cm} □ Make sure that the lead wire, paper cutter is passed through the hook on the frame assembly properly as shown above. □ Make sure that the lead wire, paper cutter is not caught between any places when securing the cutter unit. □ Install the cutter unit, B in the platen-up state. <p>□ Lubricate the point where the fixed blade of the cutter unit, B contacts the cutter frame with G-15.</p> 

Assembly H: Arranging the lead wires

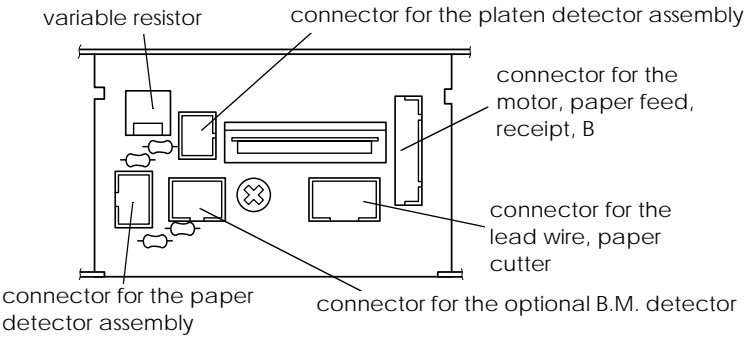
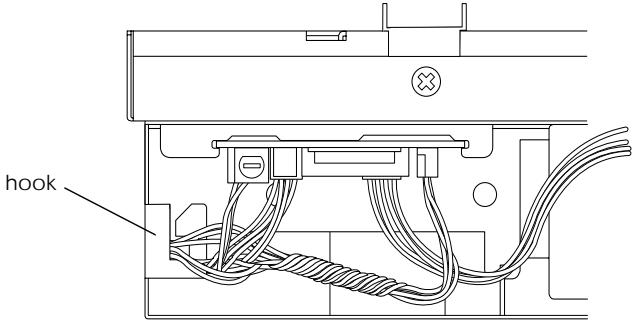
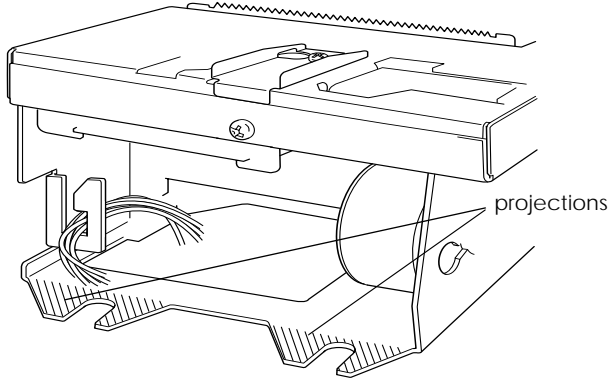
Reassembly step	Part name	Assembly procedure
1		<p><input type="checkbox"/> Insert the lead wire connectors to the connectors on the circuit board.</p>  <p><Check></p> <ul style="list-style-type: none"> <input type="checkbox"/> Make sure that the connectors are oriented properly when connecting. <input type="checkbox"/> Make sure that the connectors are inserted securely.
★		
2		<p><input type="checkbox"/> All lead wires should be passed through the hook on the frame assembly, and arranged inside of the printer.</p>  <p><Check></p> <ul style="list-style-type: none"> <input type="checkbox"/> Make sure that any of the lead wires are not caught by the projections (the colored part). <input type="checkbox"/> Make sure not to damage the coats of the lead wires when arranging the lead wires.
★		

Main Assembly I: Cable, printer and Cable, head

Reassembly step	Part name	Assembly procedure
<p>1</p> <p>★</p>	<p>Cable, head</p>	<p><input type="checkbox"/> Insert the cable, head in the connector on the thermal print head assembly.</p> <p><Check></p> <p><input type="checkbox"/> Make sure that the cable, head is oriented properly when connecting.</p> <p><input type="checkbox"/> Make sure that the cable, head is inserted securely</p>
<p>2</p> <p>★</p>	<p>Cable, printer</p>	<p><input type="checkbox"/> Insert the cable, printer in the connector on the circuit board assembly.</p> <p><Check></p> <p><input type="checkbox"/> Make sure that the cable, printer is oriented properly when connecting.</p> <p><input type="checkbox"/> Make sure that the cable, printer is inserted securely.</p> <div data-bbox="719 808 1350 1160" data-label="Diagram"> </div> <p><input type="checkbox"/> Pull out the cable, head and the cable, printer as shown below.</p> <div data-bbox="627 1285 1337 1798" data-label="Diagram"> </div>

Assembly J: Black mark detector Adjustment

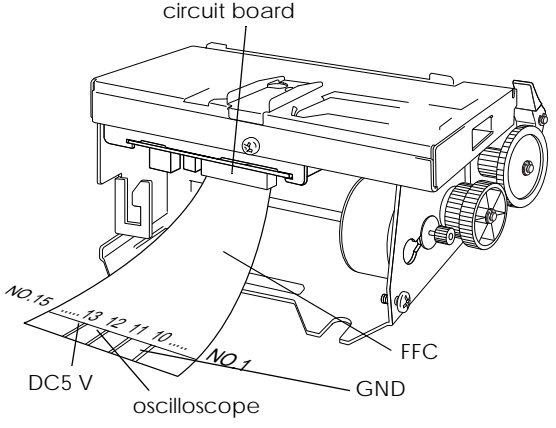
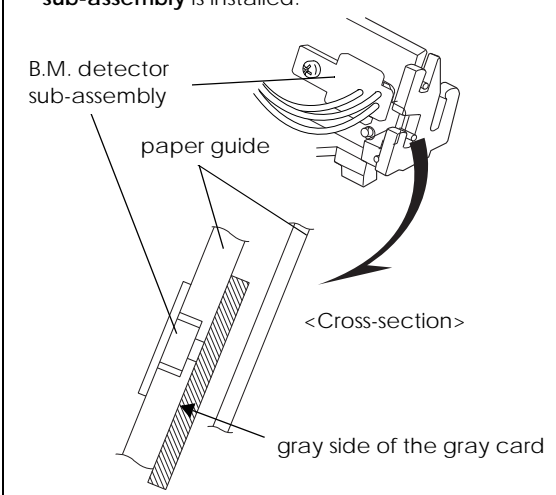
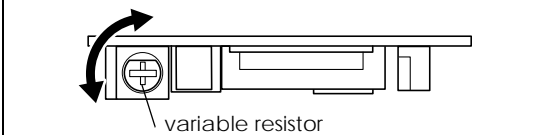
Adjustment step	Adjustment procedure	Adjustment point
<p>1</p> <p>2</p>	<p>☐ Connect the FFC terminal No.12 to an oscilloscope to display the output power voltage of the B.M. detector on the oscilloscope screen.</p> <p>☐ Input DC5 V to the FFC terminal No. 13.</p> 	
<p>3.</p>	<p>☐ Insert a "Kodak Gray Card" into the paper entrance. ("Kodak Gray Card": A commercially available card for adjusting exposure.)</p>	<p>☐ Make sure that the gray side of the card is inserted along the paper guide which the B.M. detector sub-assembly is installed.</p> 
<p>4.</p>	<p>☐ Adjust the output power voltage of the B.M. detector at 1.74 V using the variable resistor on the circuit board assembly.</p>	<p>☐ Turn the slot on the variable resistor to the right and the left with a tool such as a flat-head driver, to adjust the output power voltage.</p>  <p>☐ If the reflectance of black marks on the paper is over 10%, adjust the output voltage to 2 V or more with a 25% or less reflectance for the black marks.</p>

Main Assembly K: Cover, cable

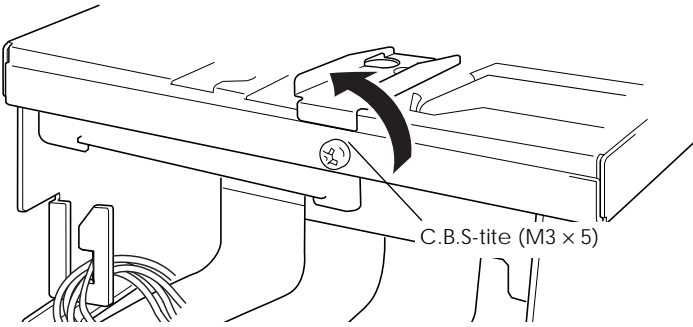
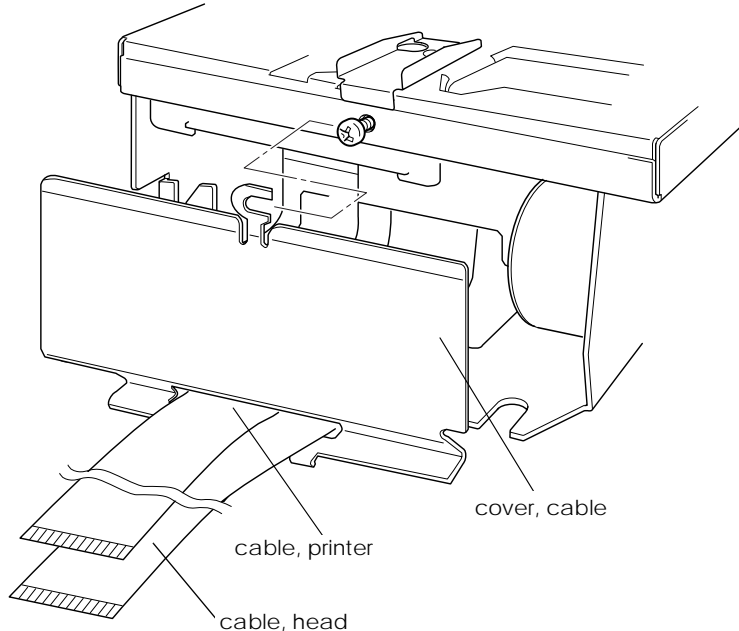
Reassembly step	Part name	Assembly procedure
1		<p><input type="checkbox"/> Loosen C.B.S-tite (M3 x 5) on the cutter unit, B.</p> 
2	Cover, cable	<p><input type="checkbox"/> Pass the cable, head and the cable printer through the hole on the cover, cable.</p>
3		<p><input type="checkbox"/> Attach the cover, cable to the mounting position on the cutter unit, B, and tighten C.B.S-tite (M3 x 5) again to secure the cover, cable.</p>
★		<p><Check></p> <ul style="list-style-type: none"> <input type="checkbox"/> Tightening torque: 834 to 932 mN•m {8.5 to 9.5 kg•cm} <input type="checkbox"/> Make sure that the cover, cable is attached securely. (frame, main) <input type="checkbox"/> Make sure that none of the lead wires are caught by any part. 

Main Assembly L: Cover, gear

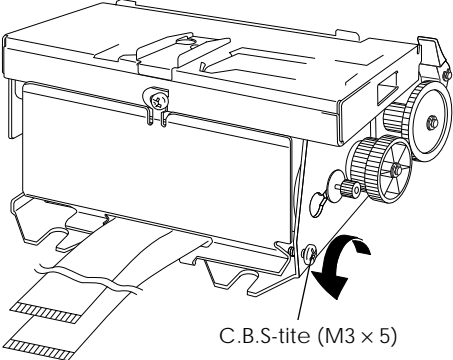
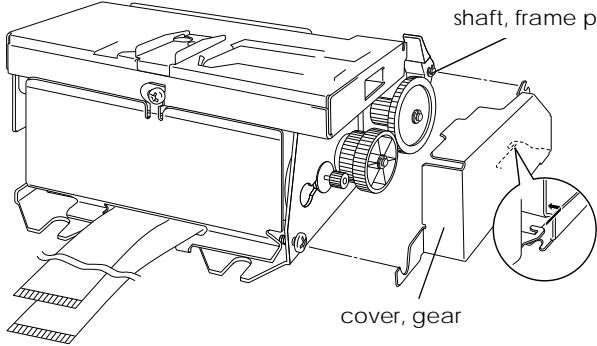
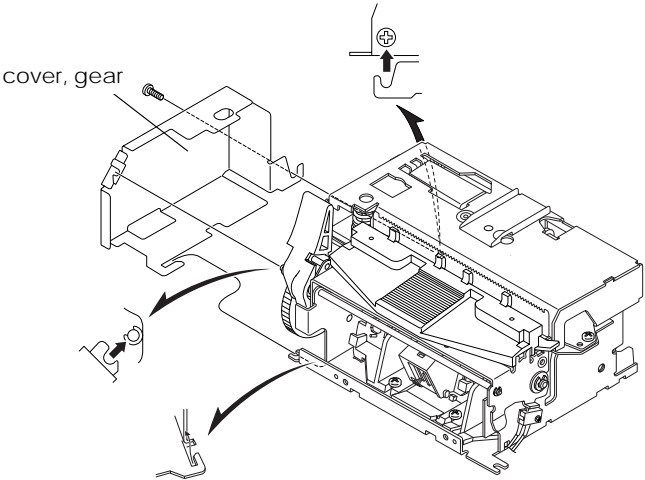
Reassembly step	Part name	Assembly procedure
1		<p><input type="checkbox"/> Loosen the lower C.B.S-tite (M3 x 5) that secures the motor, paper feed, receipt, B.</p>  <p style="text-align: center;">C.B.S-tite (M3 x 5)</p>
2	Cover, gear	<p><input type="checkbox"/> Hook the cover, gear to the frame, main and the shaft, frame platen while aligning with the mounting positions, and secure it.</p>  <p style="text-align: right;">shaft, frame platen</p> <p style="text-align: center;">cover, gear</p>
★		<p><Check></p> <p><input type="checkbox"/> Tightening torque: 834 to 932 mN•m {8.5 to 9.5 kg•cm}</p> <p><input type="checkbox"/> The hooking parts on the cover, gear are hooked securely to the frame, main.</p>  <p style="text-align: left;">cover, gear</p>

Installation of the Other Modules

Pre-assembly A: Frame, paper supply assembly

Reassembly step	Part name	Assembly procedure
1	Frame, paper supply assembly × 1 C.B.S-tite (M3 x 5) × 2	<p><input type="checkbox"/> Secure the frame, paper supply assembly with C.B.S-tite (M3 x 5).</p> <p><Check></p> <p><input type="checkbox"/> Tightening torque: 735 to 931 mN•m {7.5 to 9.5 kg•cm}</p>
2	Damper × 1	<p><input type="checkbox"/> Stick the damper on the frame, paper supply assembly.</p> <p><Check></p> <p>Damper position to stick: Right and left sides: The center from both sides. Upper and lower sides: Align with the sticking surface on the plate.</p>

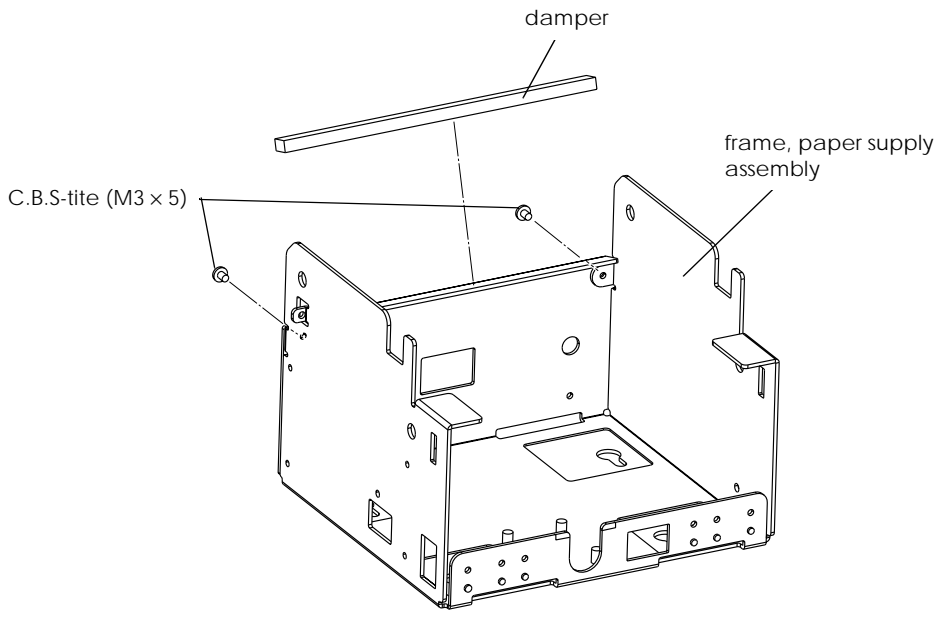

Reassembly step	Part name	Assembly procedure
3	C.B (M4 × 16) × 1 P. washer (4.3 × 0.8 × 8) × 1 Collar, screw holder × 1	<input type="checkbox"/> Attach a P. washer (4.3 × 0.8 × 8) and the collar, screw holder to a C.B (M4 × 16) screw; then attach the screw to the frame, paper supply assembly from out side.
4	Gear, frame open assembly × 1 P. washer (4.3 × 0.8 × 8) × 2 Conical S. washer-1L, 4 × 4	<input type="checkbox"/> With the flat side of the gear, frame open assembly facing to the frame side, attach it to the C.B (M4 × 16) attached in step 3 from inside of the frame, paper supply assembly ; sequently attach a P. washer (4.3 × 0.8 × 8) , four conical S. washer-1L, 4 (with each two of concave surfaces facing each other), and another P. washer (4.3 × 0.8 × 8) to the screw.
5	Plate, rotation stopper × 1 H. nut (4) × 1	<input type="checkbox"/> Attach the plate, rotation stopper to the P. washer attached in step 4 so that the bent part of the plate, rotation stopper is fit into the square hole on the frame, paper supply assembly ; then secure it with an H. nut .
9	C.B (M4 × 16) × 1 P. washer (4.3 × 0.8 × 8) × 3 Collar, screw holder × 1 Gear, frame open assembly × 1 Conical S. washer-1L, 4 × 4 Plate, rotation stopper × 1 H. nut (4) × 1	<input type="checkbox"/> Perform steps 3 to 5 for the other side of the frame, paper supply assembly .
10		<p><Check></p> <input type="checkbox"/> Tightening torque: 206 to 216 mN•m (2.1 to 2.2 kg•cm)
		<input type="checkbox"/> Apply Screw Lock Green (adhesive) to the H. nut and the C.B (M4 × 16) .

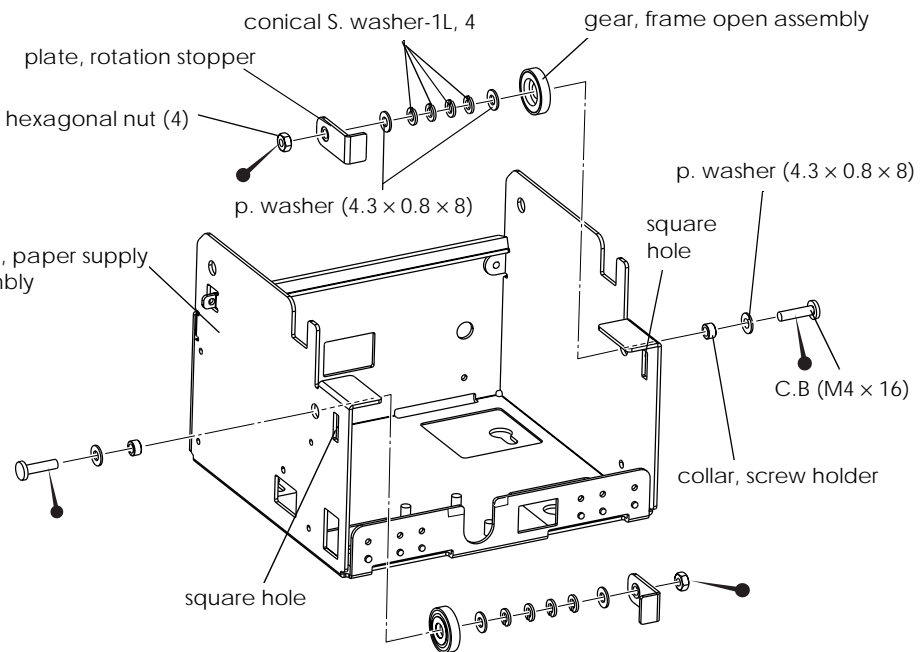

Reassembly step	Part name	Assembly procedure
11	Power supply connector assembly × 1 C.B (M3 × 4) × 4	<ul style="list-style-type: none"> ❑ Remove the switch connector from the power supply connector assembly, and insert it to the hole on the frame, paper supply. At this time, the circled mark side of the switch connector should be inside. ❑ Pass the lead wires for the power supply connector and the switch connector under the power circuit board; then attach the power supply connector assembly to the spacer and secure it with (C.B (M3 × 4)) screws. (See the enlarged view below for lead wires.) <p>< Check ></p> <ul style="list-style-type: none"> ❑ Tightening torque: 539 to 637 mN•m {5.5 to 6.5 kg•cm} ❑ When using an 8 inch roll paper diameter type, pass only the lead wires for the switch connector under the power circuit board.
12		<ul style="list-style-type: none"> ❑ Insert the switch connector into the power supply connector.
13	Plate, paper guide, L × 1 Plate, paper guide, R × 1 C.B.S-tite (M3 × 5) × 2	<ul style="list-style-type: none"> ❑ Attach the plate, paper guide, L/R to the frame, paper supply assembly and secure them with C.B.S-tite (M3 × 5) screws. <p>< Check ></p> <ul style="list-style-type: none"> ❑ Installation position of the plate, paper guide, L/R: The outer sides of the plate, paper guide L/R's oval holes are aligned with the dowels and the screw holes on the frame, paper supply, then secure the guides while pushing from above. ❑ Tightening torque: 735 to 931 mN•m {7.5 to 9.5 kg•cm}

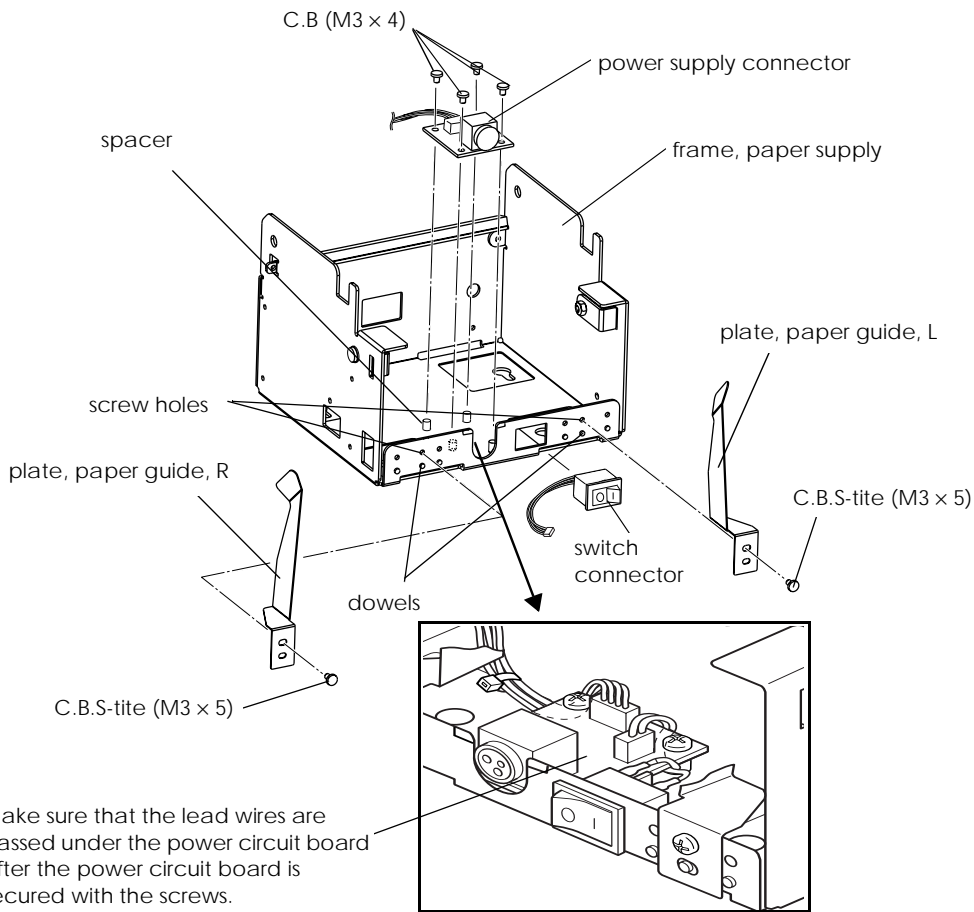

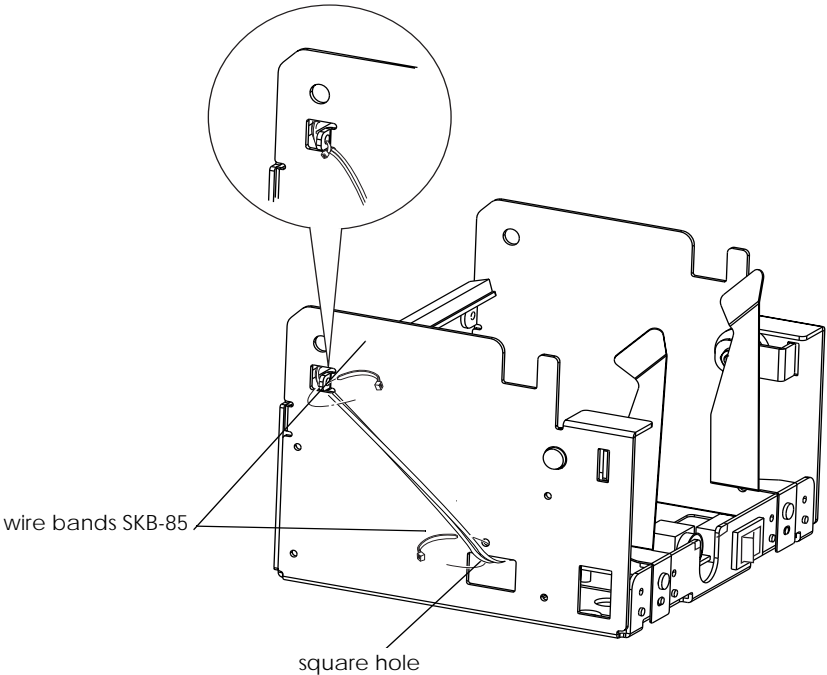
Reassembly step	Part name	Assembly procedure
14	Wire band SKB-85 × 2	<p><input type="checkbox"/> Pass the lead wires for the power supply connector through the square hole on the frame, paper supply and secure them with wire bands at two places.</p> <p>< Check ></p> <p><input type="checkbox"/> The lead wires for the upper fastening position should be arranged behind the bent part of the frame.</p>  <p>The diagram illustrates the assembly process for step 14. It shows a perspective view of a metal frame with a square hole. Two wire bands, labeled 'wire bands SKB-85', are shown being used to secure lead wires. One wire band is already partially in place, and the other is being inserted. A callout circle provides a magnified view of the wire band being secured around a power supply connector. Labels 'wire bands SKB-85' and 'square hole' point to the respective parts in the main diagram.</p>

Pre-assembly B: Roll paper holder unit

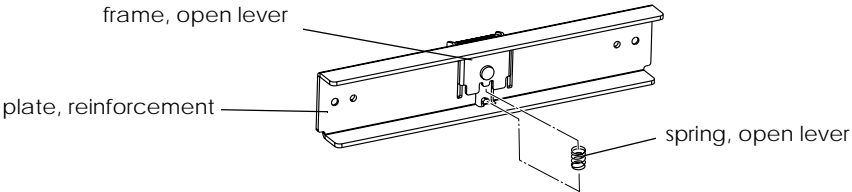
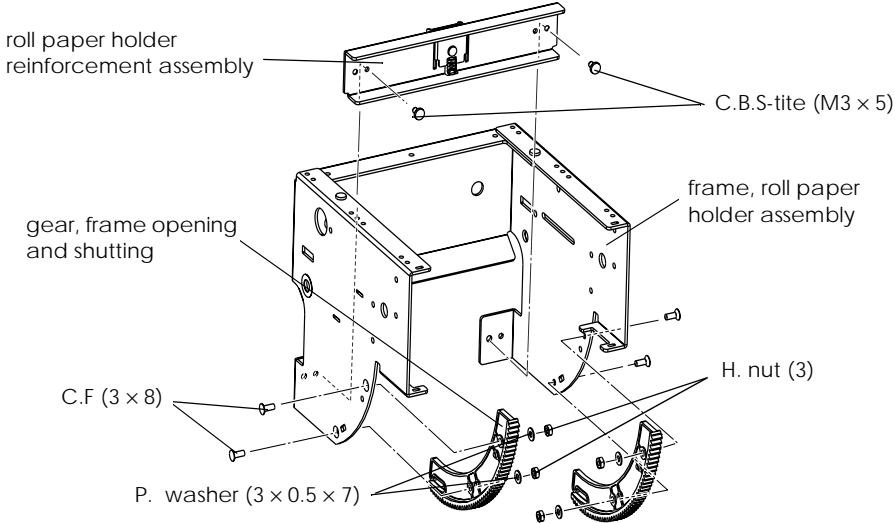
Reassembly step	Part name	Assembly procedure
1	Roll paper holder reinforcement assembly × 1 Spring, open lever × 1	<p>☐ Attach the spring, open lever to the convex parts on the frame, open lever on the roll paper holder reinforcement assembly.</p> <p>< Check > ☐ Make sure to confirm that the lever, open operates properly.</p> 
2	C.B.S-tite (M3 × 5) × 1	<p>☐ Attach the roll paper holder reinforcement assembly to the frame, roll paper holder assembly, and secure it with a C.B.S-tite (M3 × 5) screw.</p> <p>< Check > ☐ Tightening torque: 735 to 931 mN•m {7.5 to 9.5 kg•cm}</p>
3	Gear, frame opening and shutting × 1 P. washer (3 × 0.5 × 7) × 1 H. nut (3) × 1 C.F (3 × 8) × 1	<p>☐ Align the gear, frame opening and shutting with the dowels on the frame, roll paper holder from inside, and attach a C.F (3 × 8) screw to it from the outside. Secure the gear, frame opening and shutting with an H. nut (3) via a P. washer (3.2 × 0.5 × 7).</p> <p>< Check > ☐ Tightening torque: 539 to 637 mN•m {5.5 to 6.5 kg•cm}</p>
4	Gear, frame opening and shutting × 1 P. washer (3 × 0.5 × 7) × 1 H. nut (3) × 1 C.F (3 × 8) × 1	<p>☐ Perform steps 2 and 3 for the other side of the frame, roll paper holder assembly.</p> <p>< Check > ☐ Tightening torque: 539 to 637 mN•m {5.5 to 6.5 kg•cm}</p> 

Reassembly step	Part name	Assembly procedure
5	NE detector assembly × 1 Lead wire, NE detector × 1	<input type="checkbox"/> Connect the lead wires, NE detector to the NE detector assembly .NE.
6	Cover, NE detector × 1 Wire band, SKB-85 × 1	<input type="checkbox"/> Attach the NE detector assembly to the cover, NE detector away from the side with a screw hole.; then fasten the lead wires with a wire band . < Check > <input type="checkbox"/> The fastening part should be under the bent part on the cover.
7	C.B.S-tite (M3 x 5) × 1	<input type="checkbox"/> Attach the NE detector assembly to the frame, roll paper holder aligning the dowels on the NE detector assembly with the grooves on the frame; then secure the cover, NE detector with the NE detector assembly to the frame, roll paper holder with a C.B.S-tite (M3 x 5) screw. < Check > <input type="checkbox"/> Tightening torque: 735 to 931mN•m {7.5 to 9.5 kg•cm} <input type="checkbox"/> NE detector mounting position: 6 inch type; lower, and 8 inch type; upper
8	C.B.S-tite (M3 x 5) × 1	<input type="checkbox"/> Align the center of the NE detector's dowel at A on the scale gradation; then secure the NE detector with a C.B.S-tite (M3 x 5) screw. (A: Default setting) < Check > <input type="checkbox"/> Tightening torque: 735 to 931mN•m {7.5 to 9.5 kg•cm}

Reassembly step	Part name	Assembly procedure
9	Roll paper holder R assembly (for a 6 inch paper roll diameter) × 1 or Roll paper holder R assembly, B (for a 8 inch paper roll diameter) × 1 Spring, roll paper holder × 2	<input type="checkbox"/> Attach the spring, roll paper holder to the roll paper holder R assembly (or roll paper holder R assembly, B).
10	Roll paper holder R assembly (Roll paper holder R assembly, B) × 1 C.B (M3 × 8) × 2	<input type="checkbox"/> Align two dowels A on the roll paper holder, R assembly with the square holes A from the inside of the frame, roll paper holder ; then secure the assembly with C. B (M3 × 8) screws from the outside. (The dowels and square holes B for the roll paper holder R assembly, B) < Check > <input type="checkbox"/> Tightening torque: 539 to 637 mN•m {5.5 to 6.5 kg•cm}

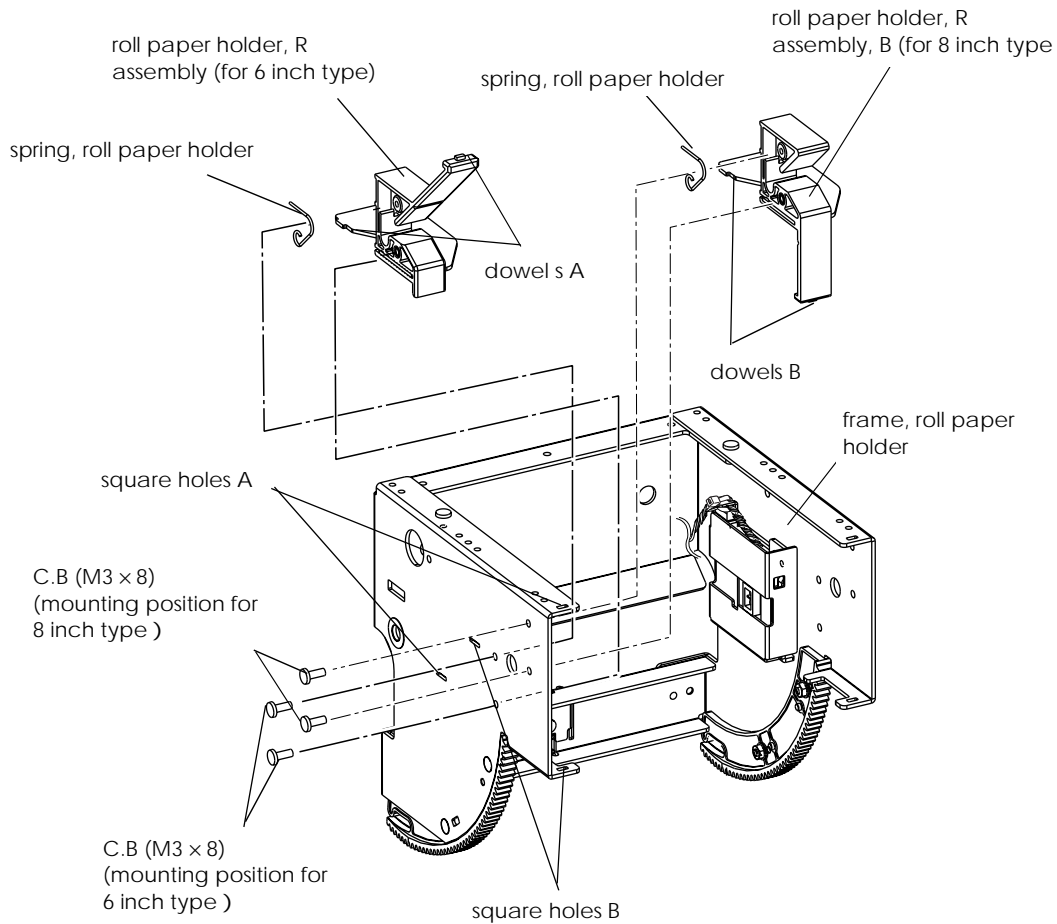

Reassembly step	Part name	Assembly procedure
11	Roll paper holder L assembly (for a 6 inch paper roll diameter) × 1 or Roll paper holder L assembly, B (for a 8 inch paper roll diameter) × 1 Spring, roll paper holder × 2	□ Attach the spring, roll paper holder to the roll paper holder L assembly (or roll paper holder L assembly, B). < Check > □ Tightening torque: 539 to 637 mN•m {5.5 to 6.5 kg•cm}
12	Roll paper holder L assembly (Roll paper holder L assembly, B) × 1 C.B (M3 × 8) × 2	□ Align three dowels C on the roll paper holder, L assembly with the square holes and the notch C on the frame and the cover, NE detector from the inside of the frame, roll paper holder ; then secure the assembly with C.B (M3 × 8) screws from the outside. (The dowels, holes and notch D for the roll paper holder, L assembly, B) < Check > □ Tightening torque: 539 to 637 mN•m {5.5 to 6.5 kg•cm}

note:
In this illustration, the roll paper holder R assembly is attached to the frame, roll paper holder.

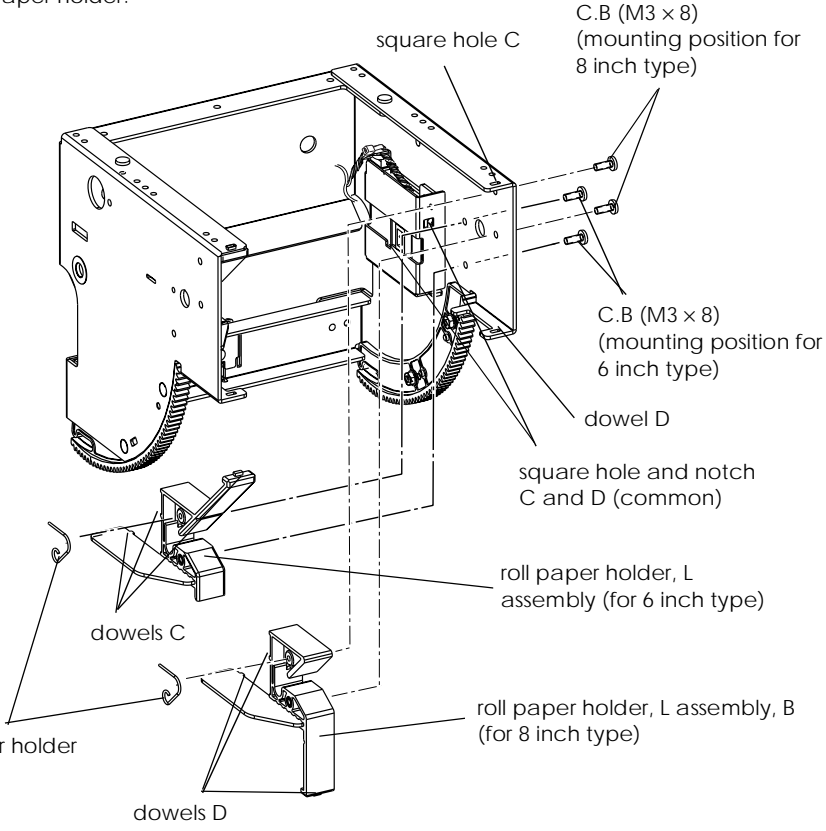

Reassembly step	Part name	Assembly procedure
13	Wire band SKB-85 × 3	<input type="checkbox"/> Fasten the lead wire, NE detector to the frame with the wire band SKB-85 at three points.
14		<input type="checkbox"/> Take out the connector of the lead wire, NE detector through the round hole on the frame. < Check > <input type="checkbox"/> The fastening part should be under the cover.

Pre-assembly C: Roll paper supply module

Reassembly step	Part name	Assembly procedure
1	frame, paper supply unit × 1 Roll paper holder unit × 1	<input type="checkbox"/> Place the frame, paper supply unit on the roll paper holder unit aligning the hole positions.
2	Collar, screw holder × 1	<input type="checkbox"/> Attach the collar, screw holder to the screw hole on the frame from outside.
3	C.B (M4 × 16) × 1 S. washer-2, 4 × 1 Plate, rotation stopper assembly × 1	<input type="checkbox"/> Attach a S. washer and the plate rotation stopper assembly to a C. B (M4 × 16) screw, and fit it into the collar, screw holder on the frame from outside so that the bent part on the plate, rotation stopper assembly is fit in the square hole on the frame.
4	P. washer (4.3 × 0.8 × 8) × 1 H. nut (4) × 1	<input type="checkbox"/> Attach a P. washer (4.3 × 0.8 × 8) from inside of the frame, then secure it with an H. nut (4) .
		< Check > <input type="checkbox"/> Tightening torque: 441 to 539 mN•m {4.5 to 5.5 kg•cm}
5	Collar, screw holder × 1 C.B (M4 × 16) × 1 S. washer-2, 4 × 1 Plate, rotation stopper assembly × 1 P. washer (4.3 × 0.8 × 8) × 1 H. nut (4) × 1	<input type="checkbox"/> Perform the same steps for the other side.
		< Check > <input type="checkbox"/> Tightening torque: 441 to 539 mN•m {4.5 to 5.5 kg•cm}
6		<input type="checkbox"/> Lubricate the H.nut (4) and the screw part with screw lock.

Pre-assembly D: Presenter table assembly

Reassembly step	Part name	Assembly procedure
1	Table, presenter × 1 P. washer (4 × 0.8 × 10) × 1 C.B.P-tite (M3 × 8) × 1	□ Attach the circuit board to the table, presenter and secure it with a C.B.P-tite (M3 × 8) screw via a P. washer . < Check > □ Tightening torque: 735 to 931 mN•m (7.5 to 9.5 kg•cm)
2	Paper detector, assembly 1 × 1	□ Slide the paper detector, assembly 1 (with a large lever) into the snap fastener on the the circuit board side. < Check > □ Make sure that the paper detector, assembly 1 is fit securely into the snap fasteners.
3	Paper detector assembly × 1	□ Slide the paper detector assembly (with a small lever) to the other snap fastener. < Check > □ Make sure that the paper detector assembly is fit securely into the snap fasteners. □ Make sure the correct mounting position for the paper detector, assembly 1 and the paper detector assembly to attach.

Pre-assembly E: Presenter frame, right assembly

Reassembly step	Part name	Assembly procedure
1	Frame, presenter, middle × 1 Frame, presenter, right × 1 C.B.S-tite (M3 × 5) × 1 C.B.S-tite (M3 × 12) × 1	<p> <input type="checkbox"/> Secure the frame, presenter, middle and the frame, presenter, right with a C.B.S-tite (M3 × 5) screw and a C.B.S-tite (M3 × 12) screw. </p> <p> < Check > </p> <p> <input type="checkbox"/> Tightening torque: 735 to 931 mN•m (7.5 to 9.5 kg•cm) </p> <p> <input type="checkbox"/> Make sure that each screw is used for the right position. </p>

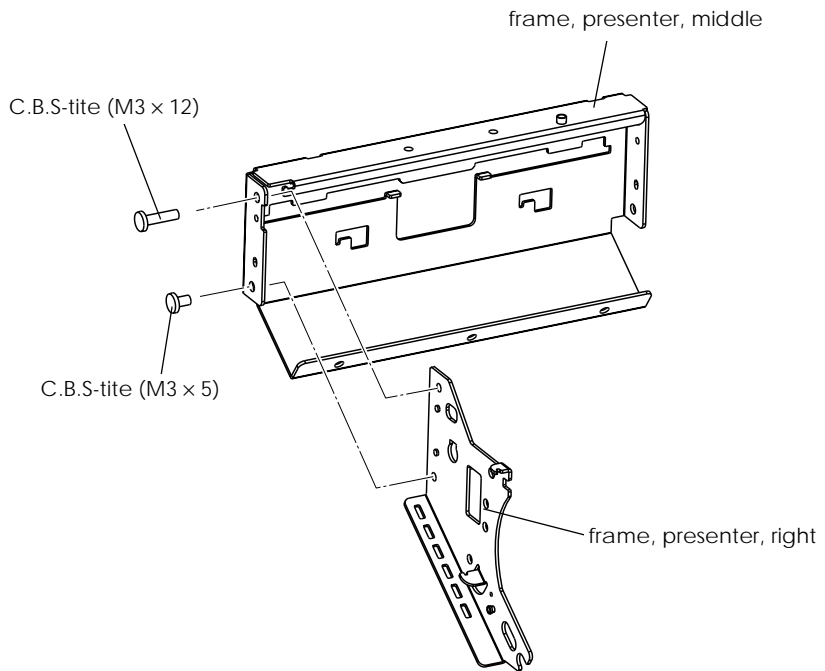

Pre-assembly F: Presenter frame, left assembly

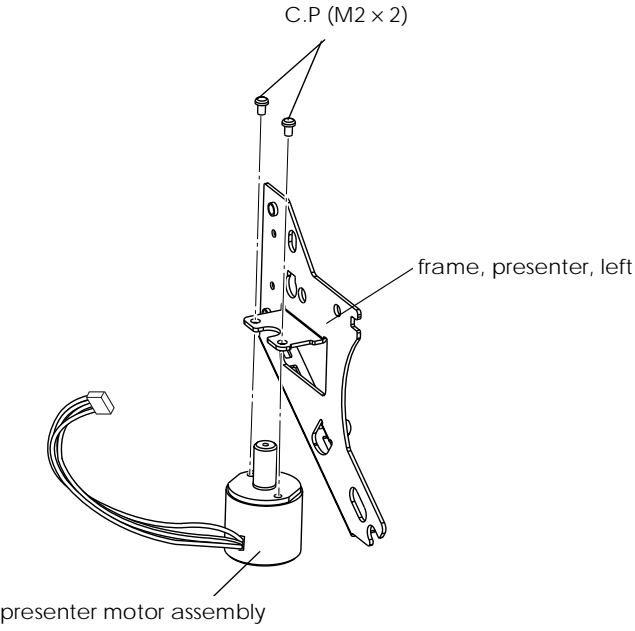
Reassembly step	Part name	Assembly procedure
1	Frame, presenter, left ×1 Presenter motor assembly ×1 C.P (M2 × 2) ×2	<p><input type="checkbox"/> Secure the presenter, motor assembly to the frame, presenter, left with C.P (M2 × 2) screws.</p> <p>< Check ></p> <p><input type="checkbox"/> Tightening torque: 294 to 392 mN•m {3.0 to 4.0 kg•cm}</p> <div style="text-align: center;">  </div>

Pre-assembly G: Paper guide assembly

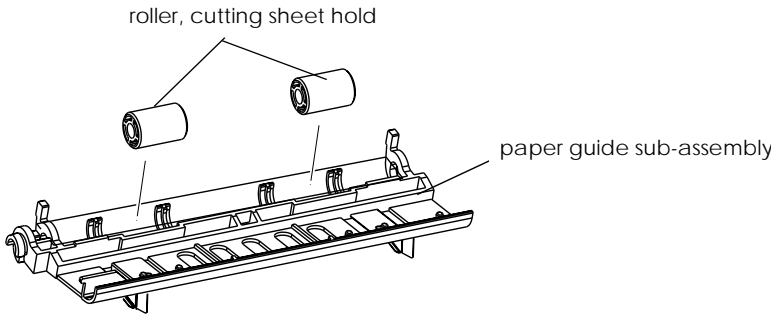
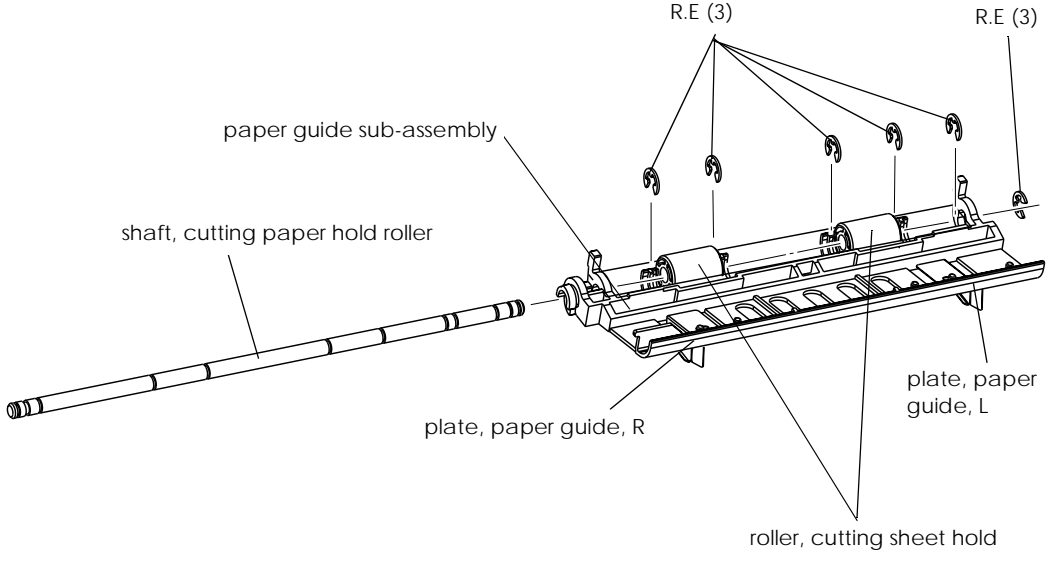
Reassembly step	Part name	Assembly procedure
1	Paper guide sub-assembly × 1 Roller, cutting sheet hold × 2	<p><input type="checkbox"/> Attach the roller, cutting sheet hold to the paper guide sub-assembly.</p> 
2	Shaft, cutting paper hold roller × 1 R.E (3) × 6	<p><input type="checkbox"/> Pass the shaft, cutting paper hold roller through the roller, cutting sheet hold and secure it with R.Es.</p> <p>< Check ></p> <p><input type="checkbox"/> Make sure not to deform the plate, paper guide, L/R of the paper guide sub-assembly.</p> 

Pre-assembly H: Cutting sheet presenter module

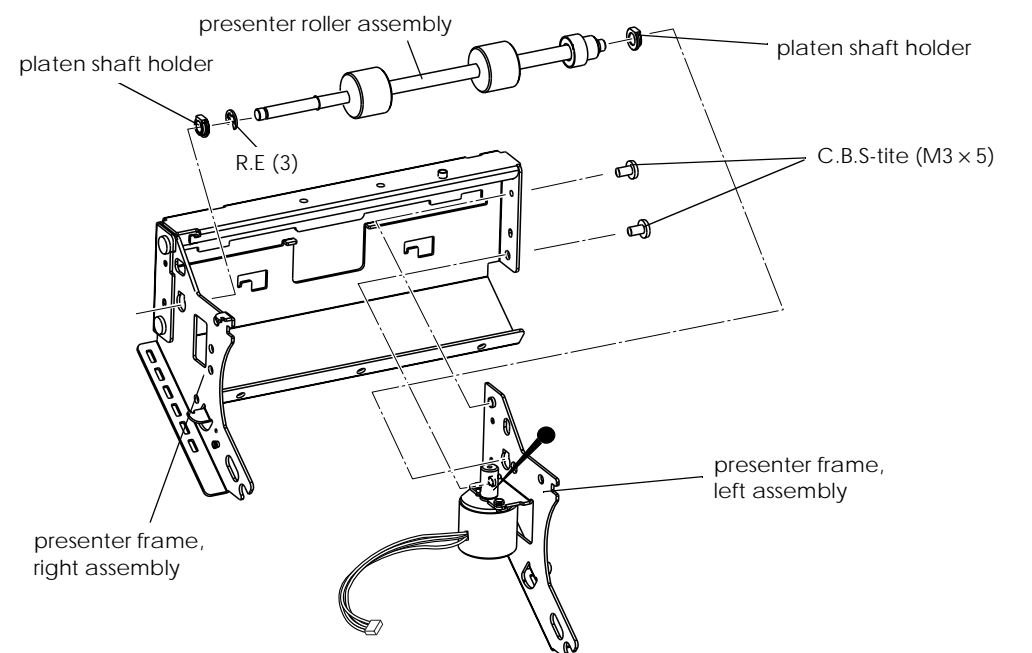
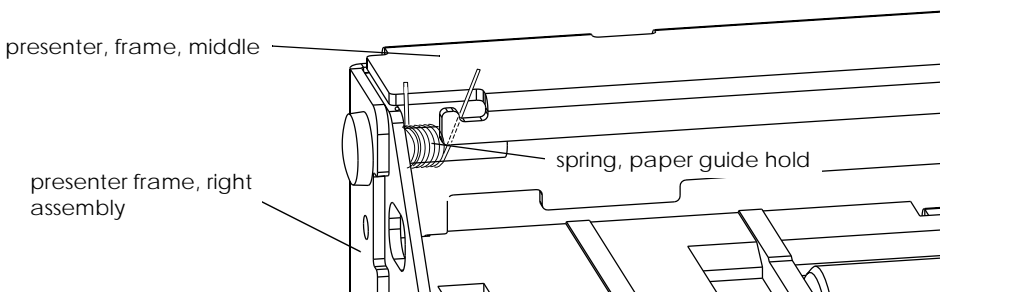
Reassembly step	Part name	Assembly procedure
1	Presenter roller assembly × 1 Platen shaft holder × 2 R.E (3) × 1 C.B.S-tite (M3 × 5) × 2 Presenter frame, R/L assembly × 1	<ul style="list-style-type: none"> ❑ Attach a platen shaft holder to the presenter frame, right assembly from inside while aligning its phase. ❑ After attaching the R.E to the presenter roller assembly, pass the assembly through the platen shaft holder on the presenter frame, right assembly from inside. ❑ After attaching a platen shaft holder to the other side of the presenter roller assembly, attach it to the presenter frame, left assembly. ❑ Attach the presenter frame, left assembly to the frame, presenter, middle from inside and secure it with C.B.S-tite (M3 × 5) screws. <p>< Check ></p> <ul style="list-style-type: none"> ❑ Tightening torque: 735 to 931 mN•m {7.5 to 9.5 kg•cm} ❑ Lubricate the motor gear on the printer motor assembly with G-36.
②		
3	Spring, paper guide hold × 1	<ul style="list-style-type: none"> ❑ Attach the spring, paper guide hold to the screw which secures the presenter frame, right assembly and the upper side of the presenter, frame, middle; then hook the longer leg of the spring to the hook on the presenter frame, middle. (temporary attachment) 

Reassembly step	Part name	Assembly procedure
4	Presenter table assembly × 1 C.B.P-tite (M3 × 8) × 2	<p> <input type="checkbox"/> Attach the presenter table assembly to the concave parts on the presenter frame, L/R assembly and the convex parts on the frame, presenter, middle; then secure it with C.B.P-tite (M3 × 8) screws. </p> <p> <i>< Check ></i> <input type="checkbox"/> Tightening torque: 735 to 931 mN•m (7.5 to 9.5 kg•cm) </p>

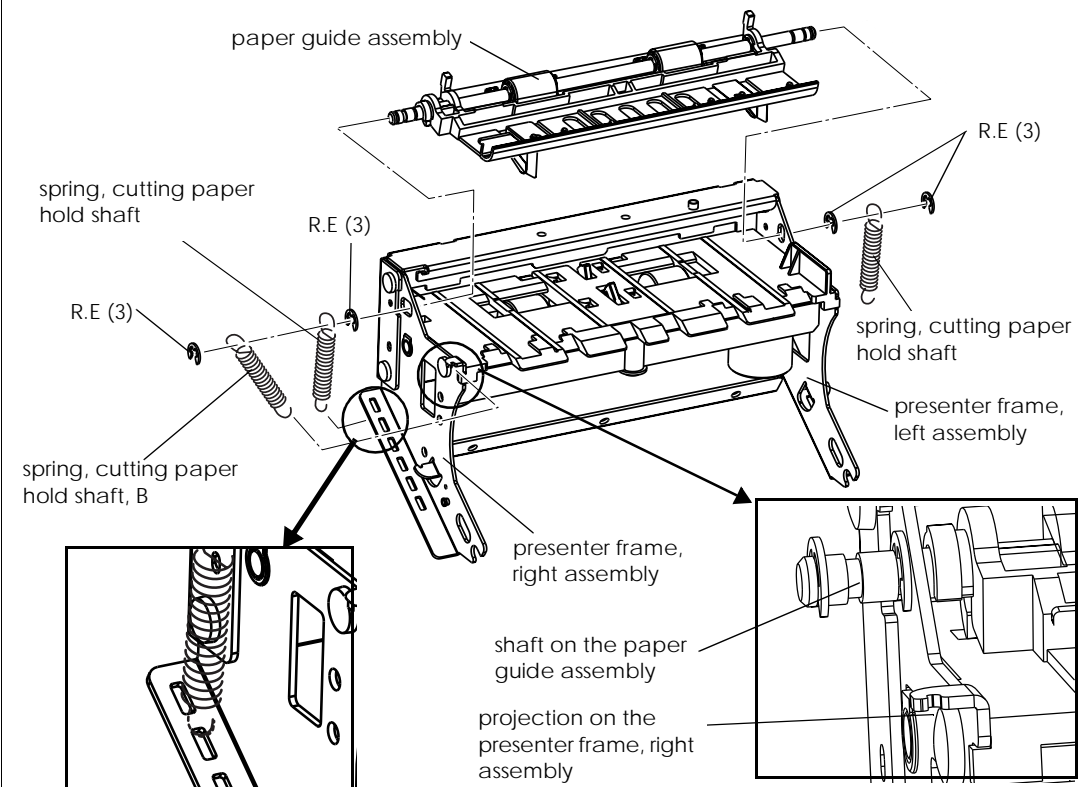
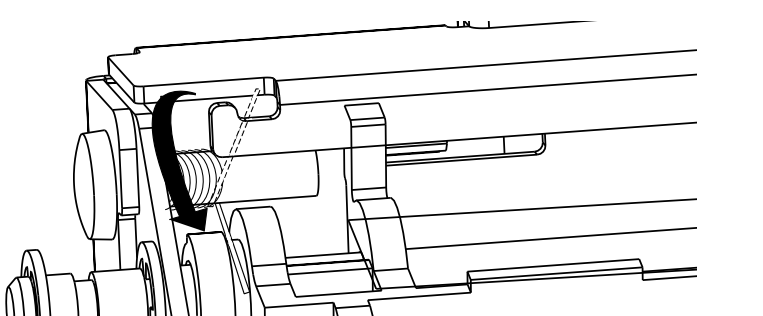
Reassembly step	Part name	Assembly procedure
5	Paper guide assembly × 1 Spring, cutting paper hold shaft × 2 Spring, cutting paper hold shaft, B × 1 R.E (3) × 4	<ul style="list-style-type: none"> ❑ Attach the paper guide assembly to the presenter frame, left assembly from inside; then attach it to the presenter frame, right assembly. ❑ Secure the both sides of the paper guide assembly with R.E from the outside of the frame. ❑ Hook the spring, cutting paper hold shaft to the square hole on the presenter frame, right assembly and the shaft of the paper guide assembly. (Attach the spring, cutting paper hold shaft on the presenter frame, left assembly side using the same steps.) ❑ Hook the spring, cutting paper hold shaft, B to the projection on the presenter frame, right assembly and the shaft of the paper guide assembly. ❑ Secure the spring, cutting paper hold shaft, B and the spring, cutting paper hold shaft on the presenter frame, left with R.Es. 
6		<ul style="list-style-type: none"> ❑ Unhook the leg of spring which has hooked on the presenter frame, middle in step 2; then hook it onto the paper guide assembly. 

Reassembly step	Part name	Assembly procedure
7	Guide, paper feeding upper × 1 C.B (M2 × 3) × 3	<input type="checkbox"/> Secure the guide, paper feeding upper to the frame, presenter, middle with C.B (M2 × 3) screws. < Check > <input type="checkbox"/> Space between the presenter frame assembly and the guide, paper feeding upper : $0.5 \pm 0.1\text{mm}$ <input type="checkbox"/> Tightening torque: 294 to 392 mN•m {3.0 to 4.0 kg•cm}
8	Plate, paper guide × 1 C.B.S-tite (M3 × 5) × 2	<input type="checkbox"/> Secure the plate, paper guide to the presenter frame, middle with C.B.S-tite (M3 × 5) screws. < Check > <input type="checkbox"/> Tightening torque: 735 to 931 mN•m {7.5 to 9.5 kg•cm}
9	paper exit guide assembly × 1 Plapoint (3 × 6) × 1	<input type="checkbox"/> Attach the paper exit guide assembly , sliding so that protrusions fit into the five notches on the frame, presenter, middle assembly ; then secure it with the plapoint . < Check > <input type="checkbox"/> Tightening torque: 73.5 to 98.0 mN•m {0.75 to 1.0 kg•cm}

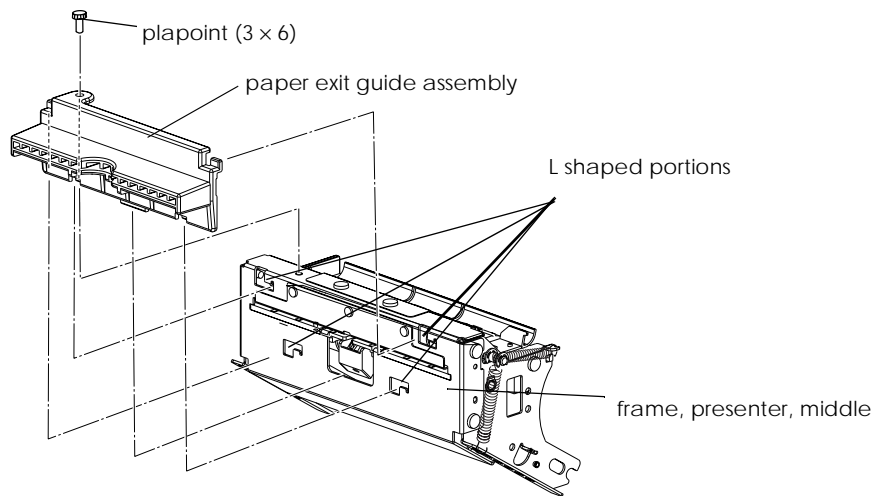
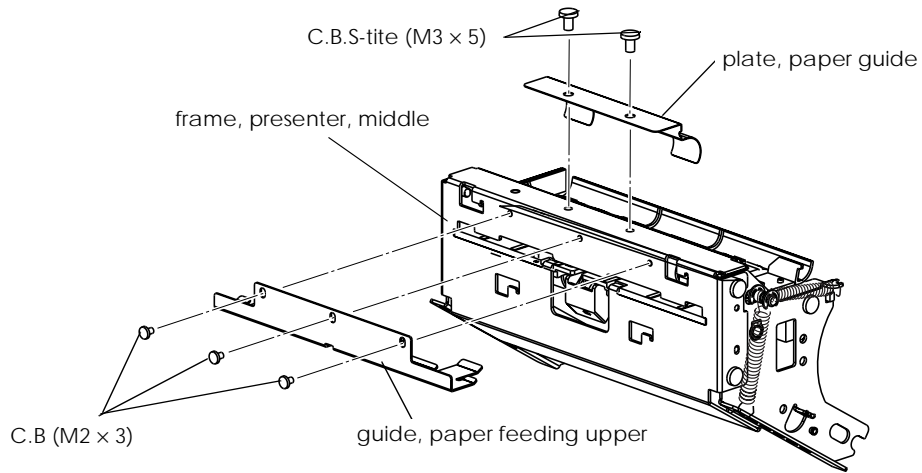

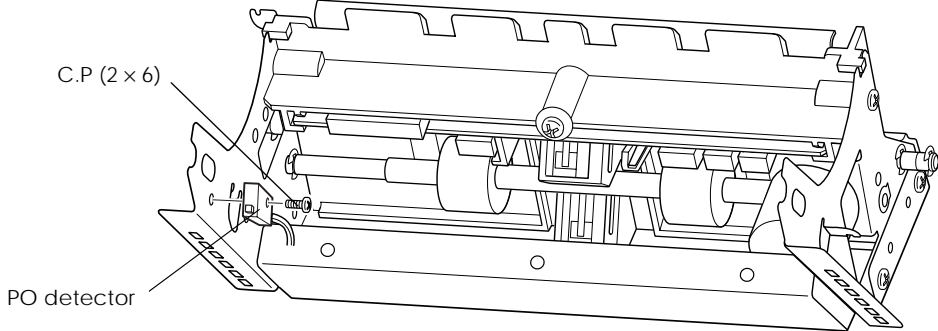
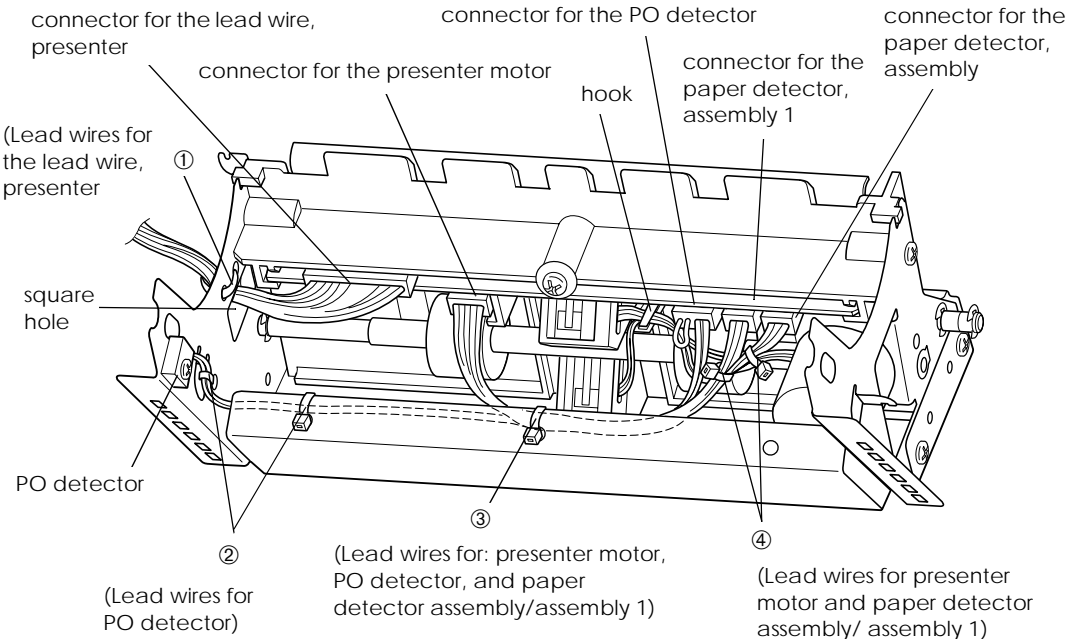
Reassembly step	Part name	Assembly procedure
10	PO detector assembly × 1 C.P (2 × 6) × 1	<ul style="list-style-type: none"> ☐ Secure the PO detector to the presenter frame, right assembly with a C.P (2 × 6) screw from inside. <p>< Check ></p> <ul style="list-style-type: none"> ☐ Tightening torque: 196 to 294 mN•m (2.0 to 3.0 kg•cm) 
11	Lead wire, presenter × 1 Wire band SKB-85 × 6	<ul style="list-style-type: none"> ☐ Connect the lead wire, presenter to the connector on the circuit board assembly and take out the lead wires through the square hole on the presenter frame, right; then fasten the lead wires to the frame with a wire band. (wire band: ①) ☐ Connect the PO detector to the connector on the circuit board assembly, and fasten the lead wires for the lead wire, presenter with wire bands at two places. (wire bands: ②) ☐ Connect the paper detector, assembly 1, the paper detector assembly and the motor presenter to the connectors on the circuit board assembly. ☐ Fasten lead wires with wire bands. (wire bands: ③ and ④) <p>< Check ></p> <ul style="list-style-type: none"> ☐ Paper detector, assembly 1: Connect to the blue connector. 

Main Assembly A: Printer module

Reassembly step	Part name	Assembly procedure
1	Fixing plate, printer assembly × 1 Printer module × 1	<ul style="list-style-type: none"> <input type="checkbox"/> Pass the cable, printer of the printer module through the square hole on the fixing plate, printer assembly. <input type="checkbox"/> Fold the cable head as shown in the illustration below.
2	C.B.S-tite (M3 × 5) × 4	<ul style="list-style-type: none"> <input type="checkbox"/> Align the holes on the printer module and the fixing plate, printer assembly, and secure them with screws. <p>< Check ></p> <ul style="list-style-type: none"> <input type="checkbox"/> Tightening torque: 735 to 931 mN•m {7.5 to 9.5 kg•cm}
3	Plate, roll paper tension × 1 Guide, roll paper tension × 2 C.B (M3 × 4) × 2	<ul style="list-style-type: none"> <input type="checkbox"/> Attach the plate, roll paper tension to the guide, roll paper tension so that the plate will be inside of the guide, aligning the holes on the plate with those on the guide; then secure it to the fixing plate, printer assembly with C.B (M3 × 4) screws. <p>< Check ></p> <ul style="list-style-type: none"> <input type="checkbox"/> Secure the guide, roll paper tension so that it is placed in the center of the paper guide of the printer module. <input type="checkbox"/> If you remove the printer module only, attach the guide, roll paper tension again. <input type="checkbox"/> Tightening torque: 539 to 637 mN•m {5.5 to 6.5 kg•cm}

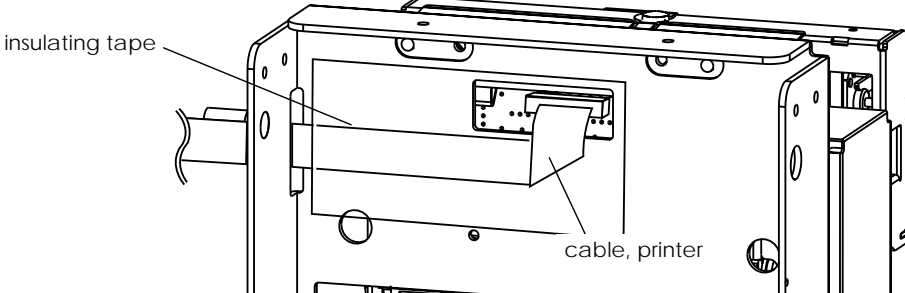
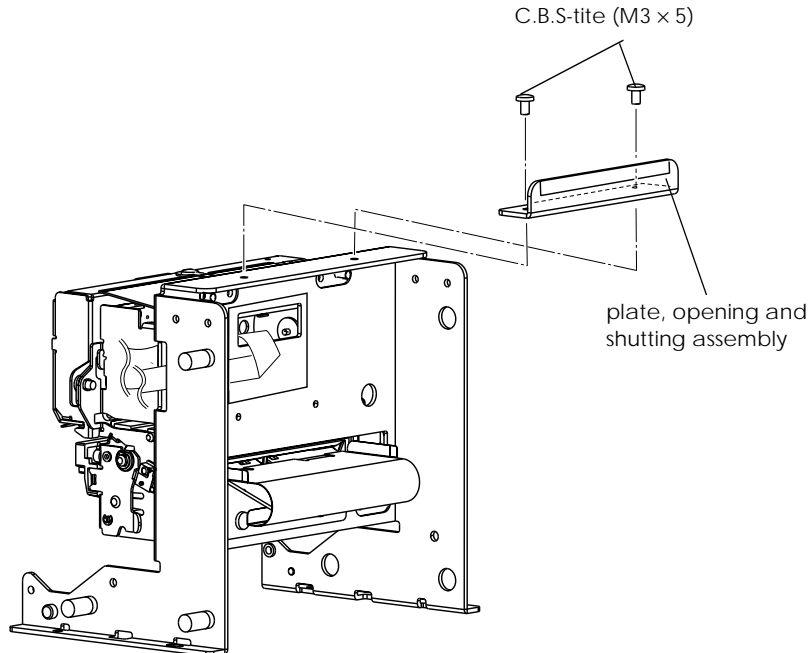
Reassembly step	Part name	Assembly procedure
4	Insulating tape (consumable)	<p><input type="checkbox"/> Fold the cable, printer and fix it with a 70 mm long insulating tape.</p> 
5	<p>Plate, opening and shutting assembly × 1</p> <p>C.B.S-tite (M3 × 5) × 2</p>	<p><input type="checkbox"/> Secure the plate, opening and shutting assembly to the fixing plate, printer assembly with C.B.S-tite (M3 × 5) screws.</p> <p>< Check ></p> <p><input type="checkbox"/> Tightening torque: 735 to 931 mN•m {7.5 to 9.5 kg•cm}</p> <p><input type="checkbox"/> Do not attach the plate, opening and shutting assembly when an optional 600 mm loop guide is equipped.</p> 

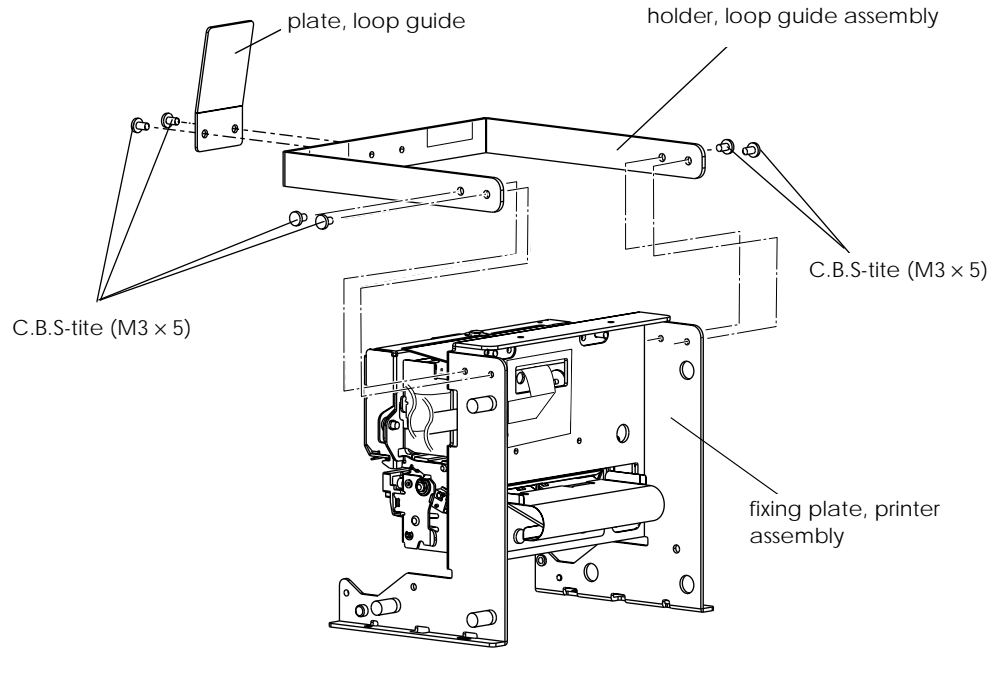
Reassembly step	Part name	Assembly procedure
< 600 mm loop guide (option) type >		
1 ~ 4		<input type="checkbox"/> Perform the same steps 1 to 4 on page 49 and 50.
5	Holder, loop guide assembly × 1 C.B.S-tite (M3 × 5) × 4	<input type="checkbox"/> Secure the holder, loop guide assembly to the fixing plate, printer assembly with C.B.S-tite (M3 × 5) screws. < Check > <input type="checkbox"/> Tightening torque: 735 to 931 mN•m {7.5 to 9.5 kg•cm}
6	Plate, loop guide × 1 C.B.S-tite (M3 × 5) × 2	<input type="checkbox"/> Secure the plate, loop guide to the fixing plate, printer assembly with C.B.S-tite (M3 × 5) screws. < Check > <input type="checkbox"/> Tightening torque: 735 to 931 mN•m {7.5 to 9.5 kg•cm}
		

Main Assembly B: Cut sheet presenter module

Reassembly step	Part name	Assembly procedure
①		<input type="checkbox"/> Lubricate the shaft, presenter fulcrums on the both sides of the fixing plate, printer assembly with G-36.
2	Cut sheet presenter module × 1	<input type="checkbox"/> Align the U notches on the cut sheet presenter module with the shaft, presenters and attach the module to the fixing plate, printer assembly .
3	Shaft, presenter fulcrum × 2 Spring, presenter × 2 C.B.S-tite (3 × 12) × 2	<input type="checkbox"/> Attach the spring, presenters to the shaft, presenter fulcrums on the both side; then secure them with C.B.S-tite (3 × 12) screws.
4		<input type="checkbox"/> Hook the spring, presenters to the hooks on the both side of the cut sheet presenter frame . < Check > <input type="checkbox"/> Tightening torque: 735 to 931 mN•m {7.5 to 9.5 kg•cm}
5	Wire band SKB-85 × 1	<input type="checkbox"/> Fasten the lead wires of the lead wire, presenter to the fixing plate, printer assembly with a wire band. < Check > <input type="checkbox"/> Fasten the lead wires with the cut sheet presenter module open.
6	Wire band SKB-85 × 1	<input type="checkbox"/> Fasten the lead wires of the lead wire, presenter on the U notch of the cut sheet presenter module.

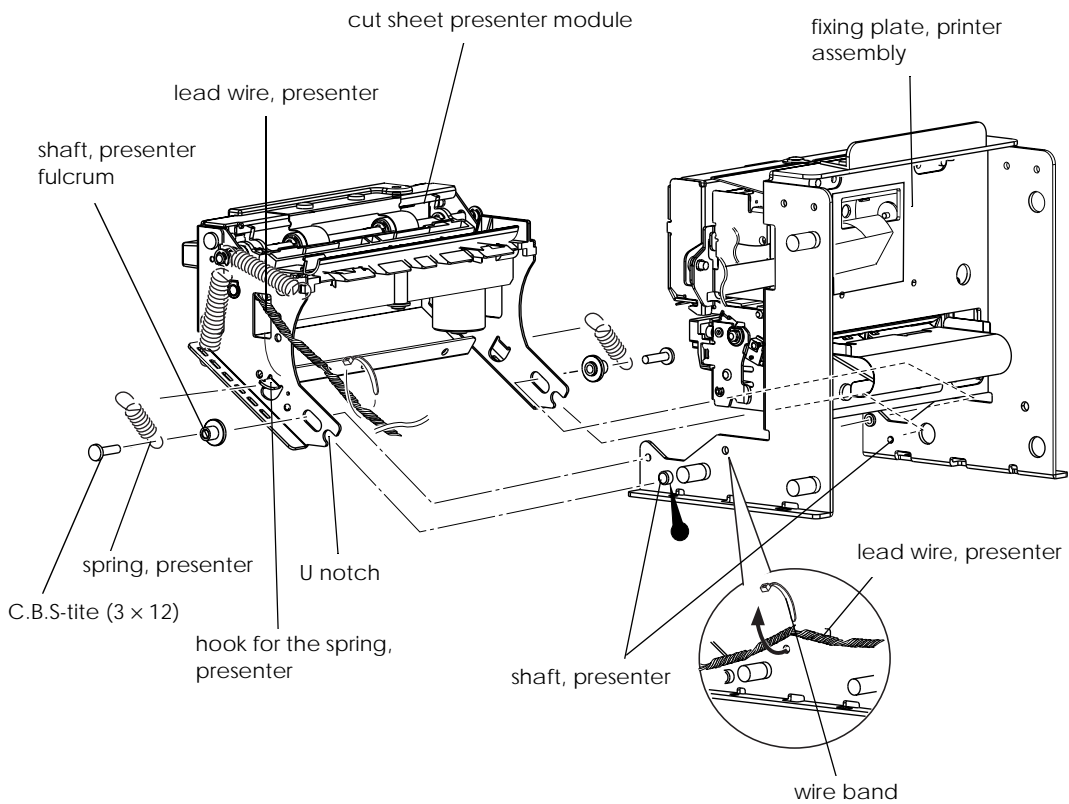

Main Assembly C: Roll paper supply module

Reassembly step	Part name	Assembly procedure
<Paper roll diameter: 6 inch type>		
1	C.B.S-tite (3 x 5) × 4	<p>❑ Attach the fixing plate, printer assembly to the roll paper holder unit and secure it with C.B.S-tite (3 x 5) screws.</p> <p>< Check ></p> <p>❑ Tightening torque: 735 to 931 mN•m {7.5 to 9.5 kg•cm}</p>
<Paper roll diameter: 8 inch type>		
1	Roll paper supply module × 1 Spacer, paper supply × 2 C.B.S-tite (3 x 5) × 4	<p>❑ Attach the spacer, paper supply to the roll paper supply module and secure it with C.B.S-tite (3 x 5) screws.</p> <p>< Check ></p> <p>❑ Tightening torque: 735 to 931 mN•m {7.5 to 9.5 kg•cm}</p>
2	C.B.S-tite (3 x 5) × 4	<p>❑ Attach the fixing plate, printer assembly to the spacer, paper supply and secure it with C.B.S-tite (3 x 5) screws.</p> <p>< Check ></p> <p>❑ Tightening torque: 735 to 931 mN•m {7.5 to 9.5 kg•cm}</p>

Main Assembly D: Control circuit board and Cover, circuit boards upper/ lower

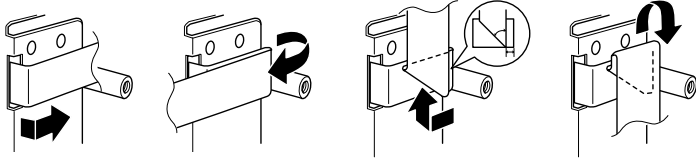
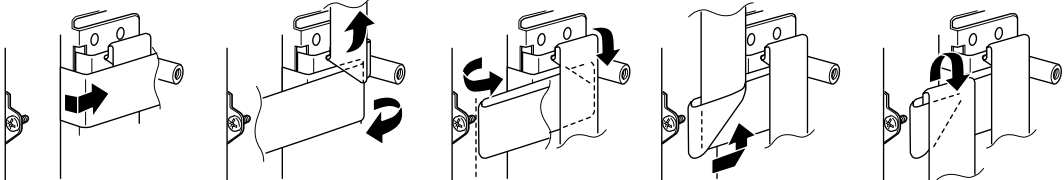
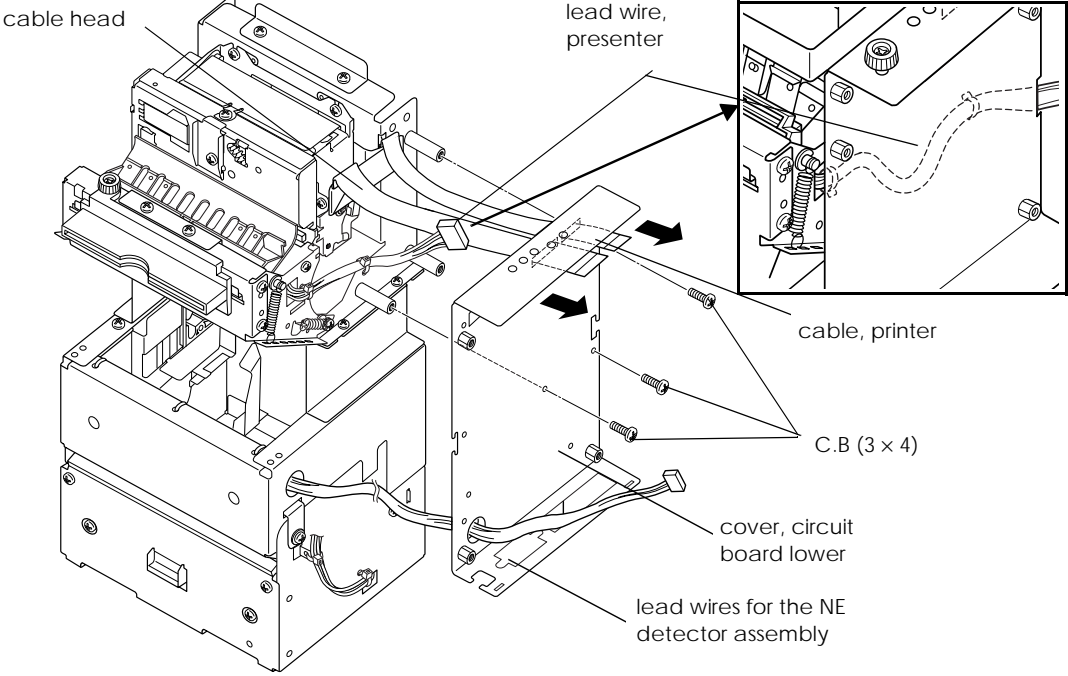
Reassembly step	Part name	Assembly procedure
1	Cover, circuit board lower	<p>❑ Fold the cable, printer and the cable head of the printer module (see below), and pass them through the square hole on the cover, circuit board lower.</p> <p><How to fold the cable, printer></p>  <p><How to fold the cable head></p> 
2		<p>❑ Pass the lead wires for the NE detector assembly through the round hole on the cover, circuit board lower. At this time, the lead wire, presenter from the square hole on the presenter frame, right assembly should be under the cover, circuit board lower.</p>
3	C.B (3 × 4) × 3	<p>❑ Attach the cover, circuit board lower to the fixing plate, printer and secure it with C.B (3 × 4) screws.</p> <p>< Check ></p> <p>❑ Tightening torque: 539 to 637 mN•m {5.5 to 6.5 kg•cm}</p>
		

Reassembly step	Part name	Assembly procedure
4	C.B (3 × 4) × 4 Control circuit board module × 1	<ul style="list-style-type: none"> ❑ Connect the cable head and the cable, printer of the printer module to the connectors on the control circuit board module ❑ Pass the lead wire, NE detector between the cover, circuit board lower and the control circuit board module; then secure the control circuit board module to the cover, circuit board lower with C.B (3 × 4) screws. <p>< Check ></p> <ul style="list-style-type: none"> ❑ Tightening torque: 735 to 931 mN•m {7.5 to 9.5 kg•cm} ❑ When securing the control circuit board module, slightly push it downward. Pass the hooks of the parallel interface through the hole on the circuit board, lower.
5	LED switch circuit board assembly × 1 C.B (M3 × 4) × 2	<ul style="list-style-type: none"> ❑ Secure the LED switch circuit board assembly with C.B (M3 × 4) screws. <p>< Check ></p> <ul style="list-style-type: none"> ❑ Tightening torque: 735 to 931 mN•m {7.5 to 9.5 kg•cm}
6	H. nut (2.6) × 2	<ul style="list-style-type: none"> ❑ Secure the serial connector to the cover, circuit board lower with H. nuts. <p>< Check ></p> <ul style="list-style-type: none"> ❑ Tightening torque: 392 to 588 mN•m {4.0 to 6.0 kg•cm}

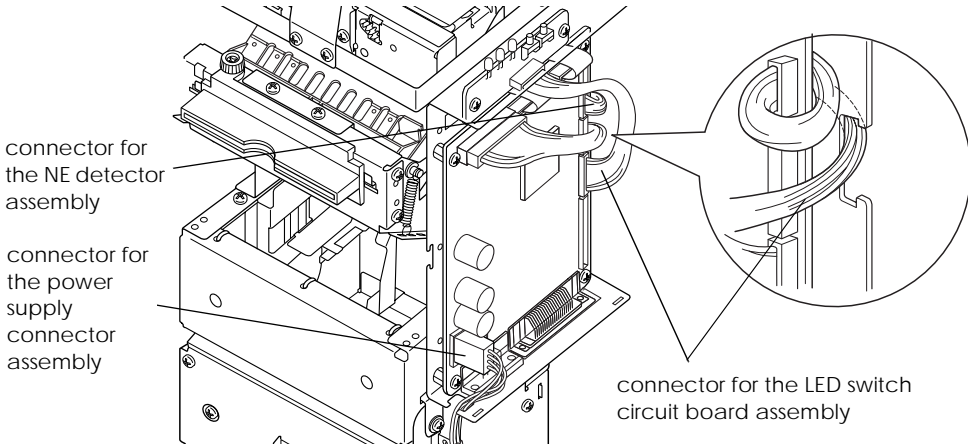
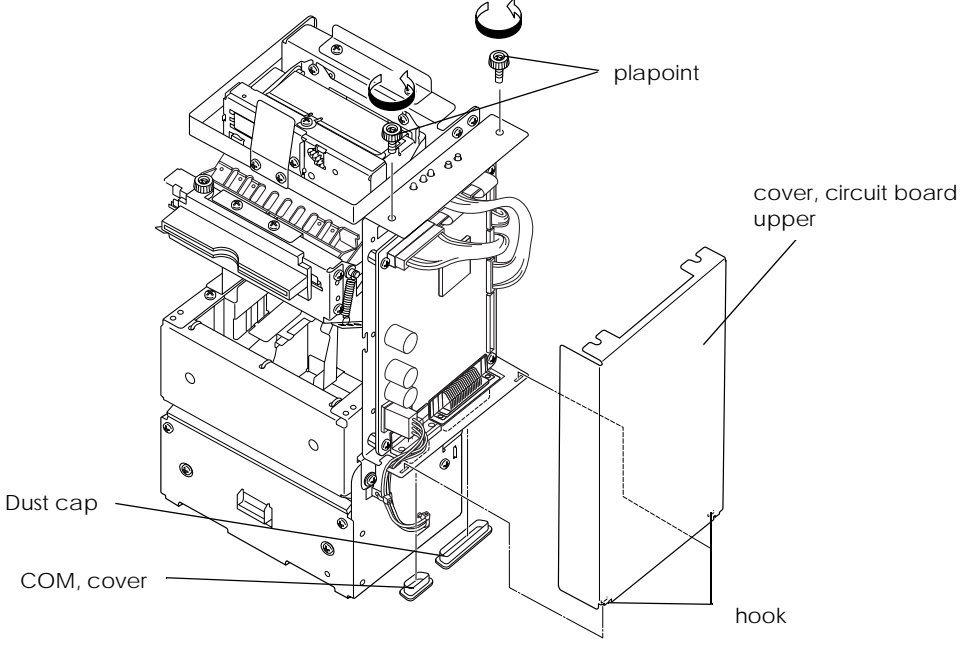
Reassembly step	Part name	Assembly procedure
7		<p>❑ Connect the NE detector assembly, the cut sheet presenter module, the power supply connector assembly, and the LED switch circuit board assembly to the connectors on the control circuit board module. At this time, pass the lead wire, presenter on the notch on the cover, circuit board lower.</p>  <p>connector for the NE detector assembly</p> <p>connector for the power supply connector assembly</p> <p>connector for the LED switch circuit board assembly</p>
8	<p>Cover, circuit board upper × 1</p> <p>Plapoint, 3 × 6 × 2</p>	<p>❑ Attach the cover, circuit board upper and secure it with plapoints.</p> <p>< Check ></p> <p>❑ Tightening torque: 73.5 to 98 mN•m {0.75 to 1.0 kg•cm}</p> <p>❑ Two hooks on the cover, circuit board upper are fit into the square holes on the cover, circuit board lower.</p> <p>❑ The lead wires should not be caught.</p>
9	<p>Dust cap × 1</p> <p>COM, cover × 1</p>	<p>❑ Attach the dust cap and the COM, cover to the serial and parallel connectors on the control circuit board module.</p>  <p>Dust cap</p> <p>COM, cover</p> <p>plapoint</p> <p>cover, circuit board upper</p> <p>hook</p>

Main Assembly E: Roll paper shaft assembly

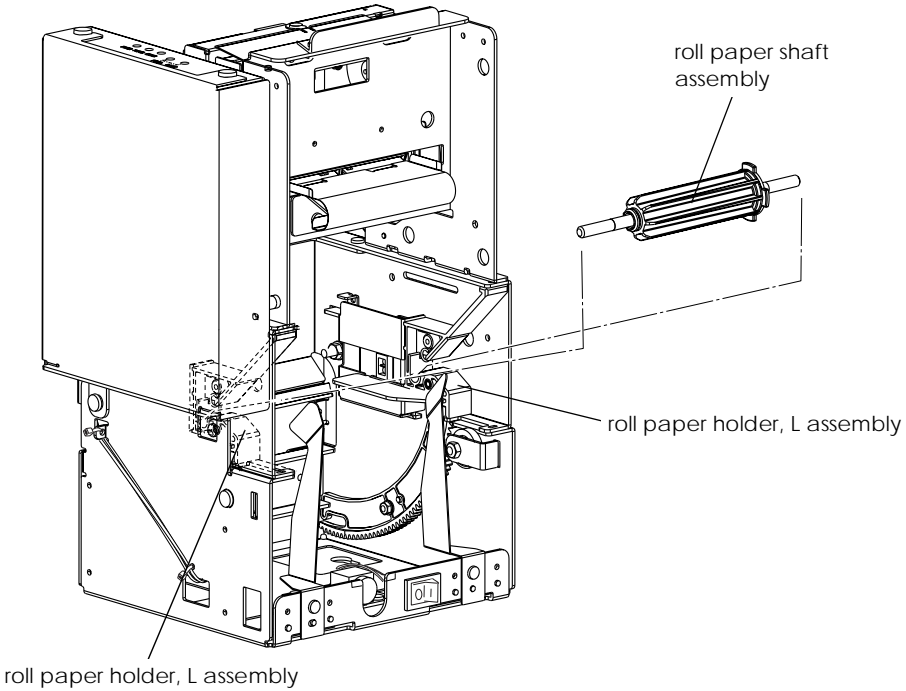
Reassembly step	Part name	Assembly procedure
1	Roll paper shaft assembly, A × 1 (Roll paper shaft assembly, B) (Roll paper shaft assembly, C)	<input type="checkbox"/> Attach the roll paper shaft assembly to the roll paper holder L/R assembly. 

Appendix

EU-T432 Exploded Diagram

Note:
The parts inside dotted lines are optional parts.

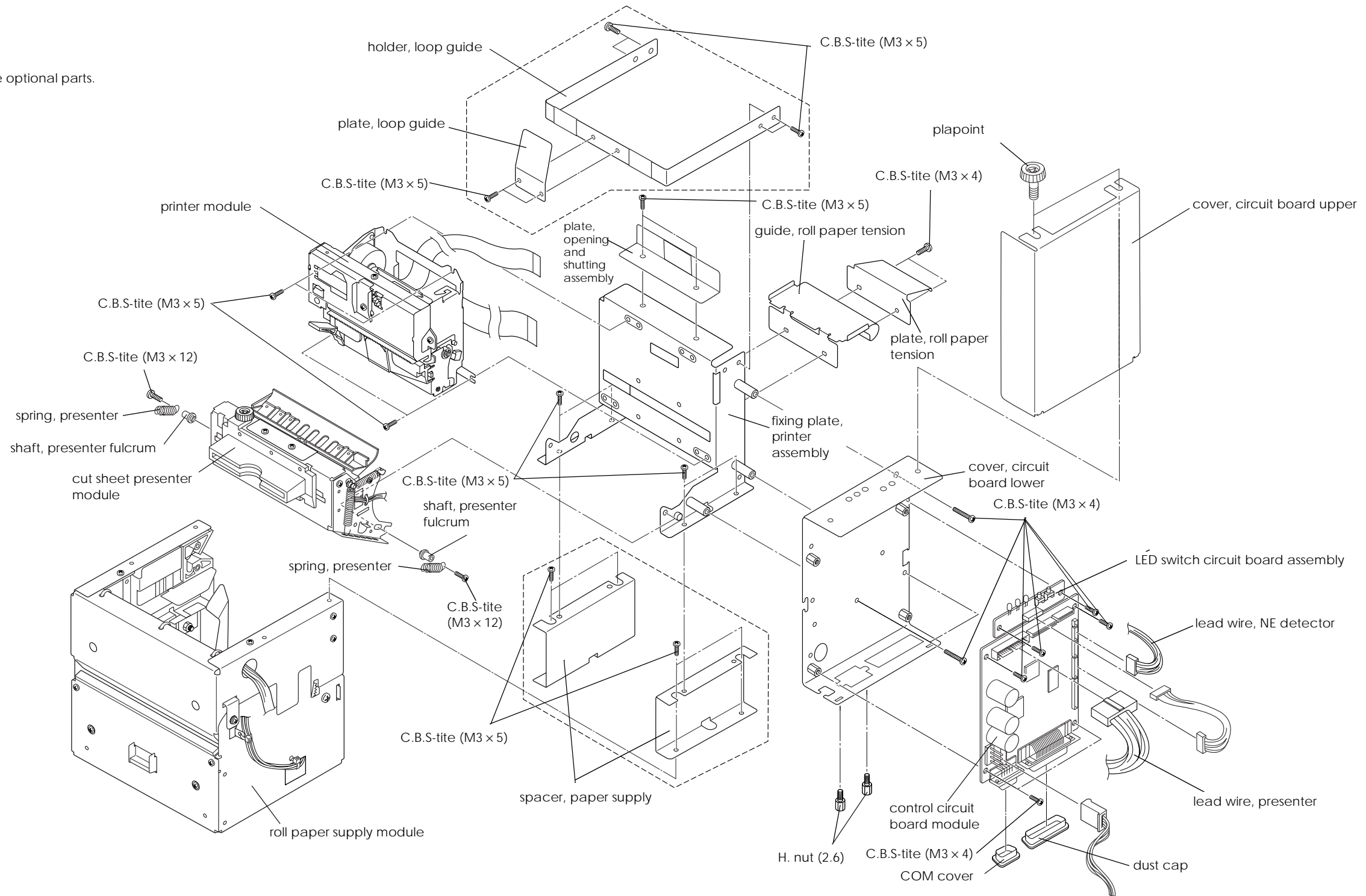

Printer Module Exploded Diagram

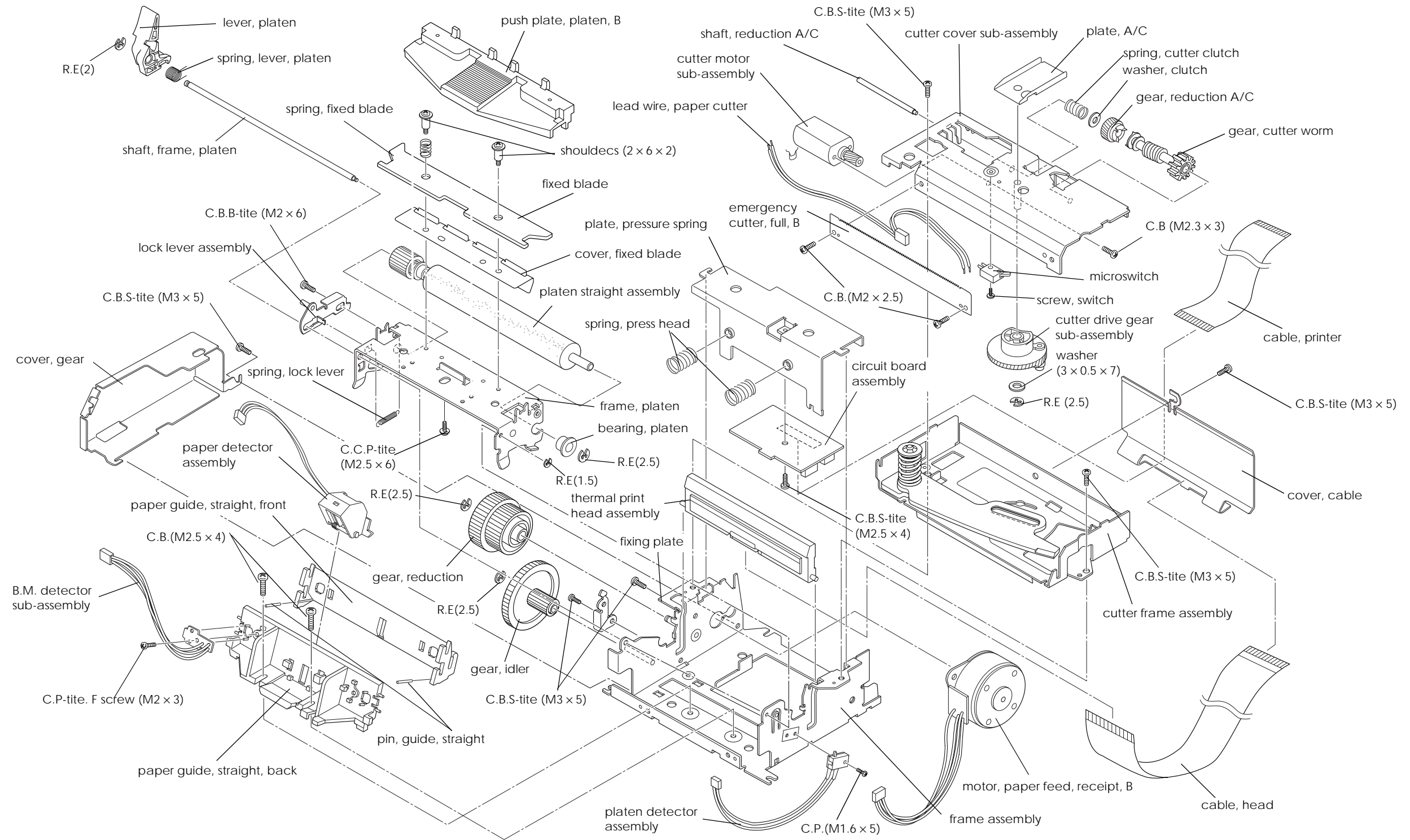

Cut Sheet Presenter Module Exploded Diagram

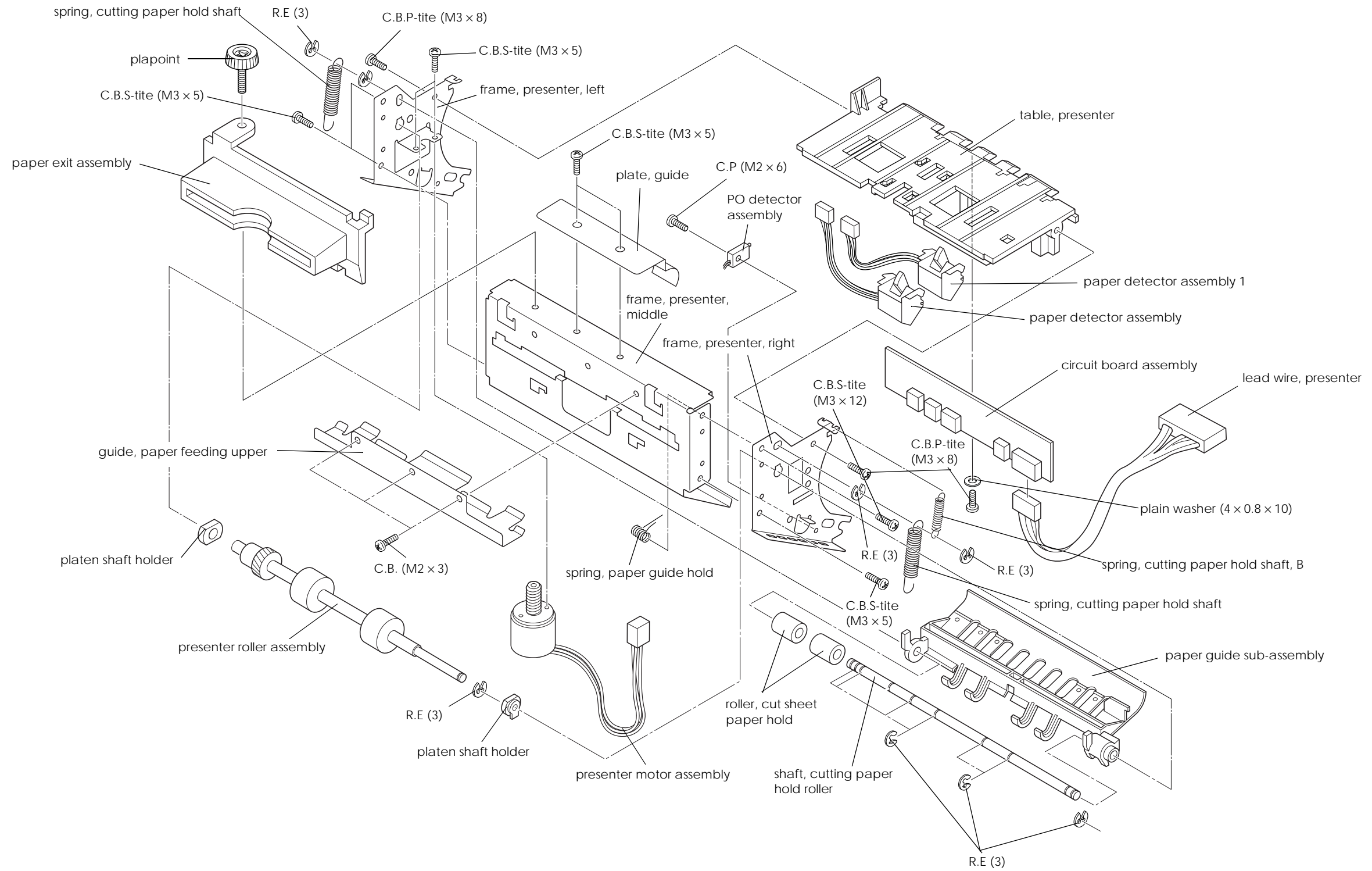

Roll Paper Supply Module Exploded Diagram

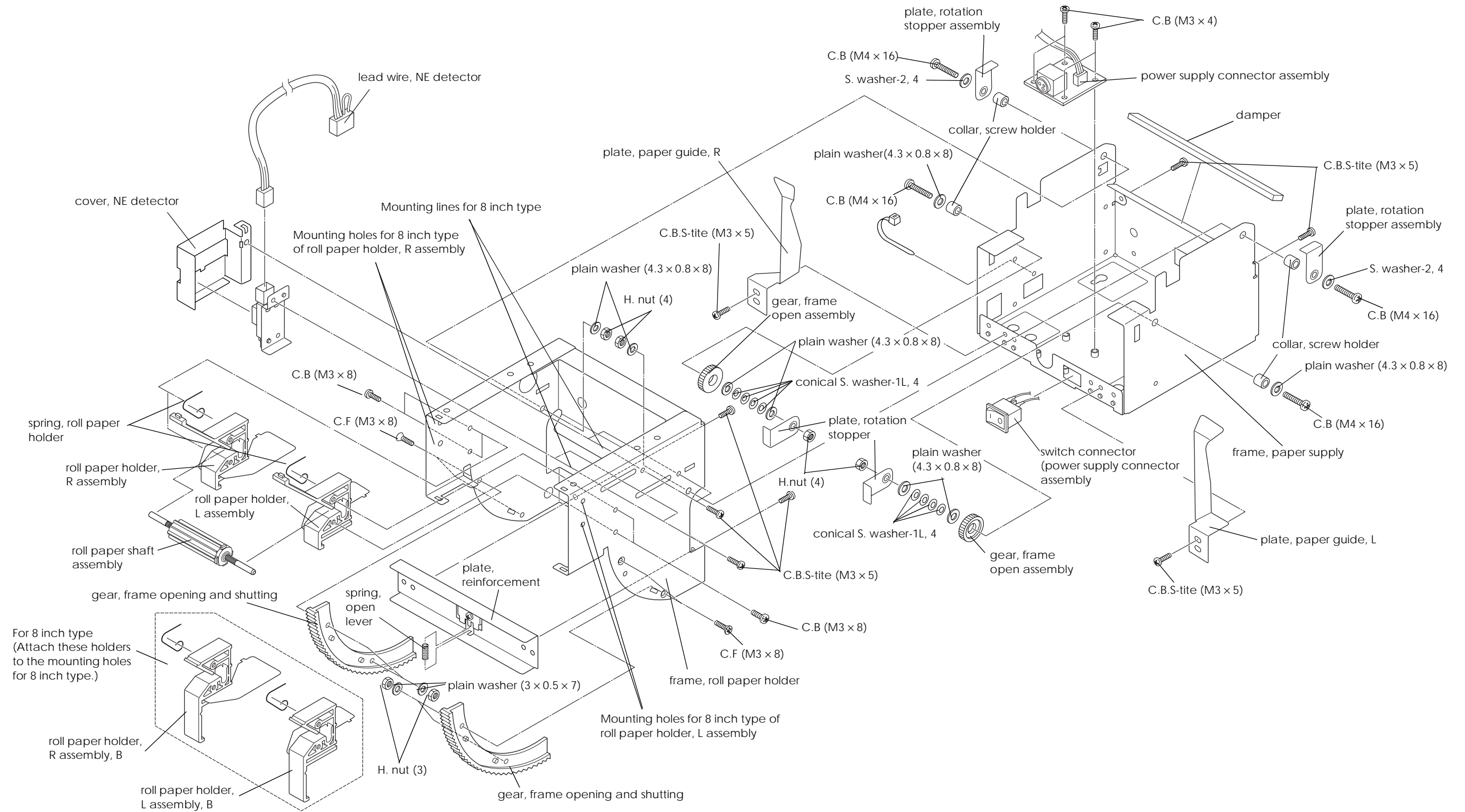

EU-T432 Lubrication Diagram

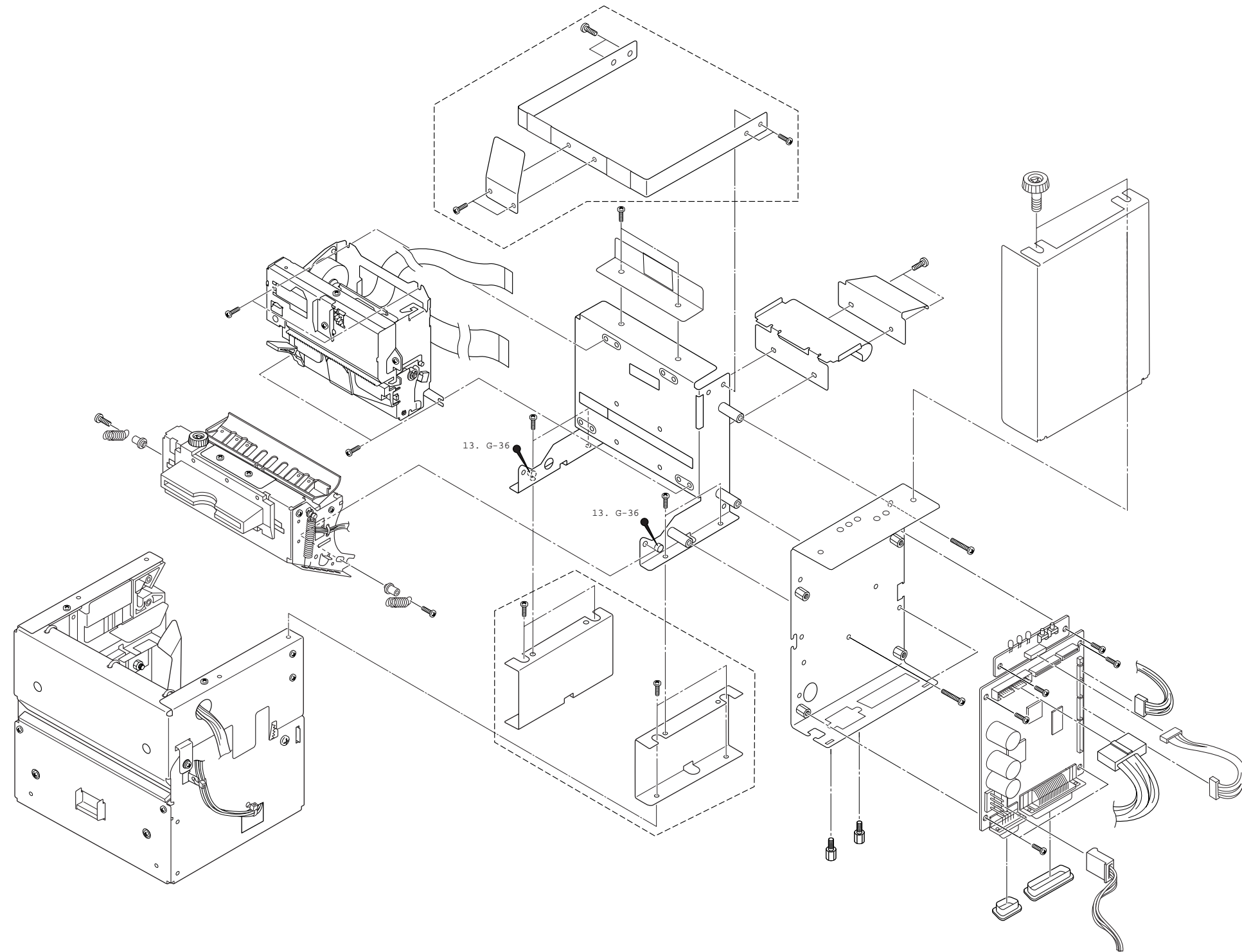

Printer Module Lubrication Diagram

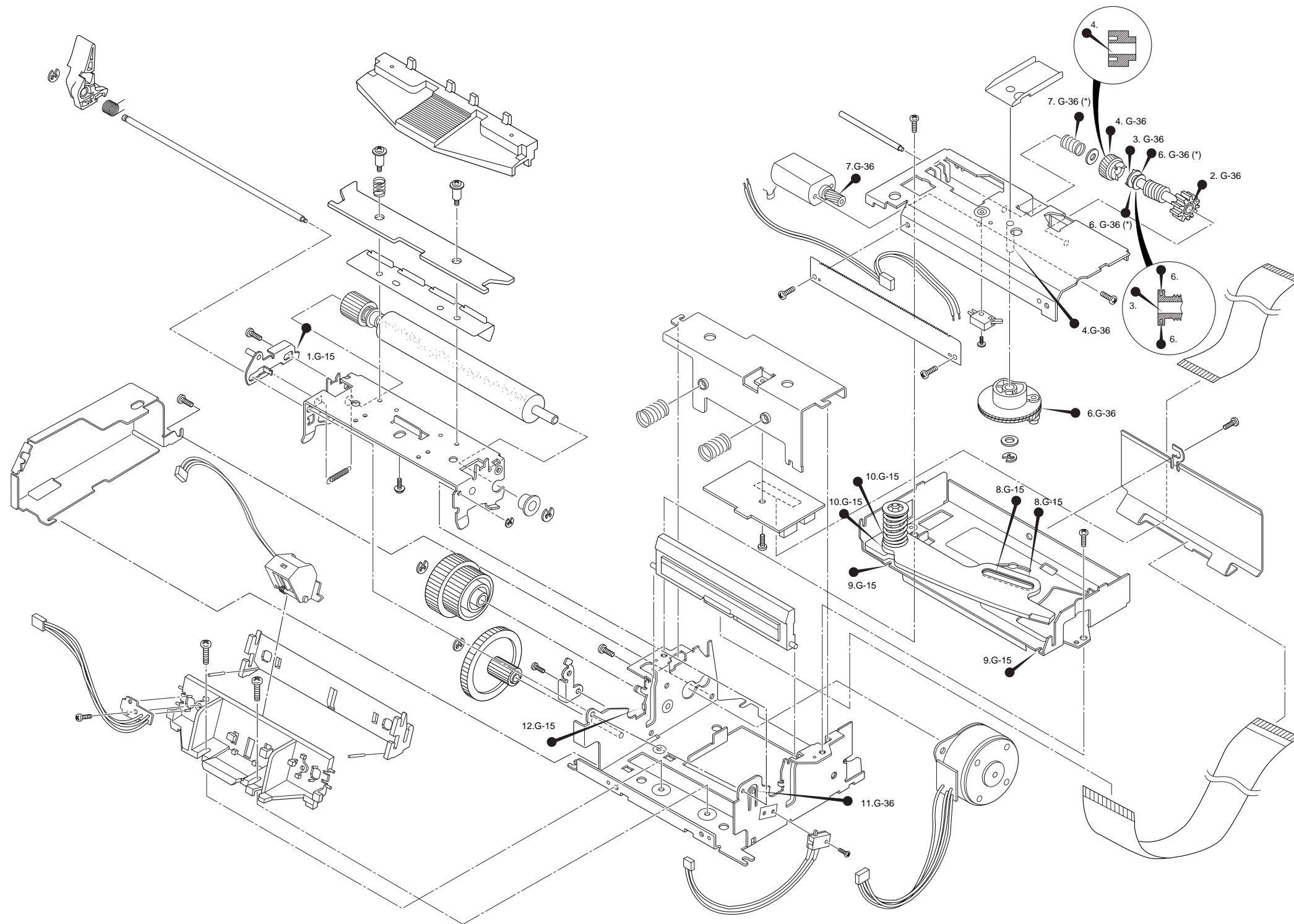

Cut Sheet Presenter Module Lubrication Diagram

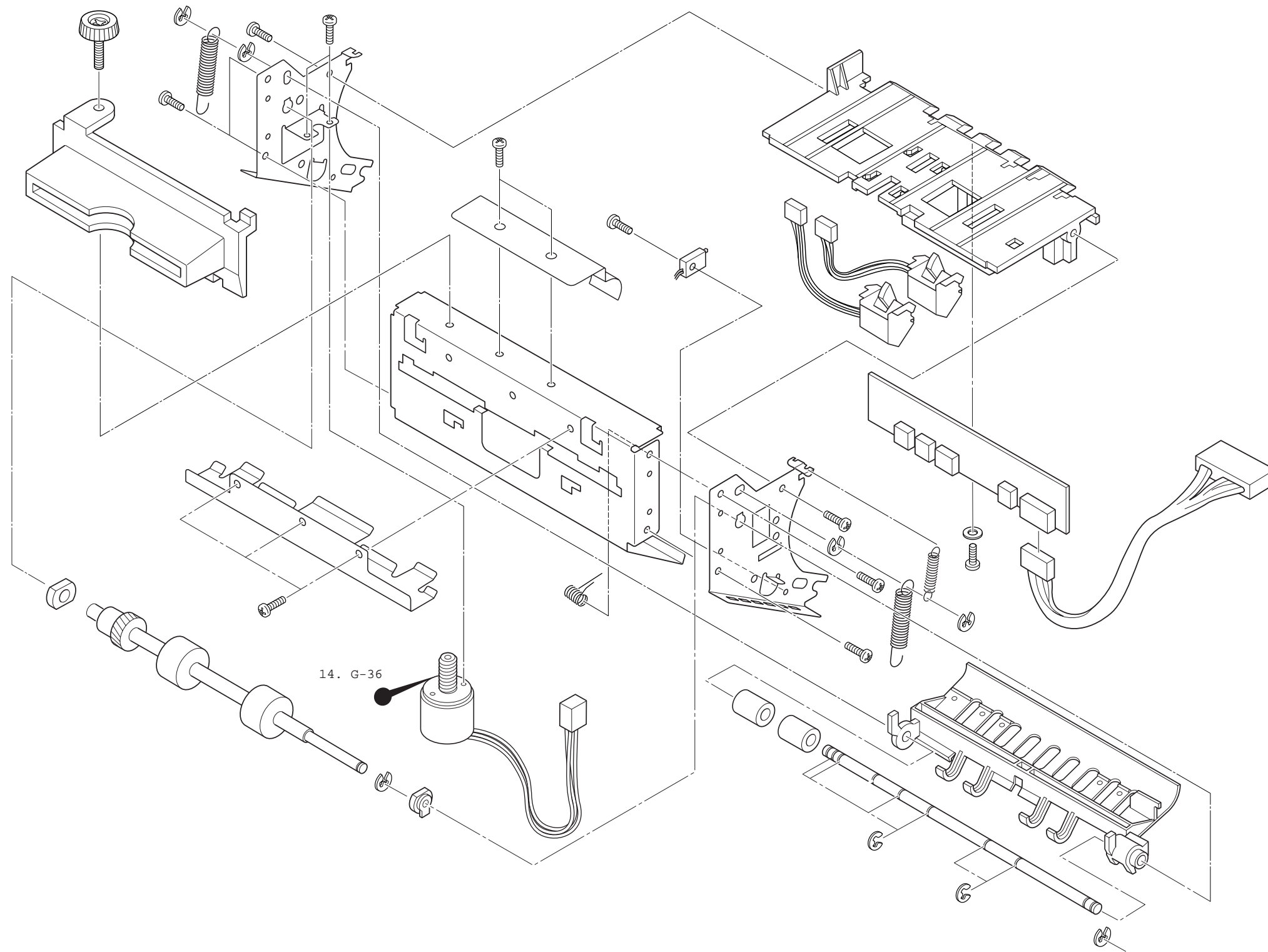

Roll Paper Supply Module Adhesive Diagram

Note: Screw Lock Green is used for all adhesive parts of the cut sheet presenter module.

