

Automated Ticketing

TABLE OF CONTENTS

1280 Kiosk	78
<i>Automated Truck Scale System</i>	
Weigh Out/Printer Kiosk	79
<i>Automated Truck Scale System</i>	
Weigh/Check In Kiosk	80
<i>Automated Truck Scale System</i>	
Printer Kiosk	80
<i>Direct Thermal Printer Kiosk</i>	
Printer Kiosk	81
<i>Thermal-transfer Printer Kiosk</i>	
OnTrak® Enterprise	82
<i>Truck Data Management Software</i>	
OnTrak®	83
<i>Truck Data Management Software</i>	
Kiosk Safety Swing-away Arm	84
<i>Self Centering Kiosk Mount</i>	
Vehicle Loop Detector	86
EMX Lite Preformed Loops®	86
RFID	87
<i>TransCore® SmartPass®</i>	
Multiprotocol Rail Reader and Parapanel Antenna	87
RFID Access Tags	88
RFID Transportation Tags	88
HID RFID Cards	89
HID RFID Readers	89
Remote HID Box	90
HID Long Range Readers	90
TagMaster CT-45	91
<i>Network IP Camera with License Plate Recognition (LPR)</i>	
Vivotek IP8361	91
<i>Network IP Outdoor Camera</i>	
Photo Eyes	92
Traffic Light Kits	93
Scale Intercom	94
Ethernet Serial Servers	94

Product names, logos, brands and other trademarks featured or referred to within this publication are the property of their respective trademark holders.

1280 Kiosk

Automated Truck Scale System



Shown with optional features

Standard Features

- 12-inch 1280 color touchscreen
- Stainless steel or mild steel enclosure
- 1,500 NIT display
- Two serial ports RS-232 or RS-485/422
- Operator prompting
- Formattable tickets
- Transmits weight to remote display
- 120 or 220 VAC
- 460 MB onboard database
- Ethernet TCP/IP (wired and Wi-Fi)
- Web server
- Direct thermal printer
- Internal heater
- Slide door access to ticket
- Works with standard 1280 programs - customization available
- One-year warranty

Optional Features

- A/D cards
- RFID reader
- Gate control
- Loop detector input
- QWERTY keyboard
- 12-key keypad
- Credit card reader (US and Canadian currency)
- Stop/Go remote display traffic light control

AUTOMATED TICKETING

Part Numbers/Price

Part#	Description	Price
199512	ATS Kiosk, 1280 Kiosk TOP 12 inch with 1500 NIT Display, Painted MS Enclosure, Thermal Printer, With Printer Slide Door Access and Basket, Heater 115VAC, No A/D	\$8,215.00
218355	ATS Kiosk, 1280 Inbound 12 inch with 1500 NIT Display, Painted MS Enclosure, NO A/D, 115 VAC	\$7,195.00

Options/Accessories

Part #	Description	Price
176452	HID smart card reader	\$695.00
119693	200 watt heater	\$925.00
119761	Ethernet unmanaged switch, five port	\$315.00
196709	Kiosk option, A/D single-channel, includes DIN rail and terminals	\$665.00
196710	Kiosk option, A/D dual-channel, includes DIN rail and terminals	\$765.00
119946	Single port Ethernet server	\$485.00
120040	Dual port Ethernet server	\$675.00
33490	Relay rack four-channel Opto 22 style with screws	\$125.00
21159	Internal transient protection	\$245.00

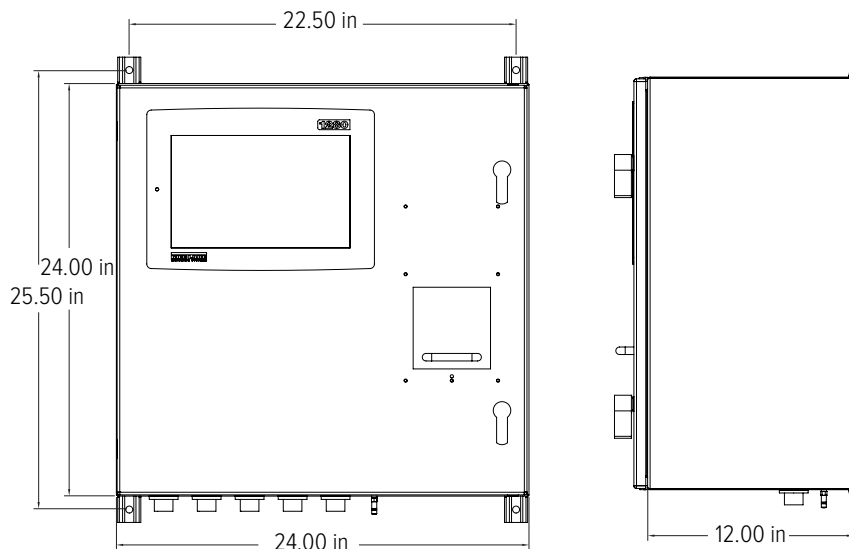

Weigh Out/Printer Kiosk

Automated Truck Scale System



Shown with optional features

Standard Features

Weigh Out/Printer Kiosk

- 920i® HMI with sun shield
- Six serial ports
- 1 MB database memory
- Two option slots
- Slide door access to ticket
- 8-in paper roll
- Operator prompting
- Formattable tickets
- Transmits weight to remote display
- Stop/Go remote display traffic light control
- Direct thermal kiosk printer
- One-year warranty

Weigh Out/Printer Kiosk Options

- Ethernet TCP/IP (wired and Wi-Fi options available)
- Single or dual channel A/D cards
- RFID reader
- Currency acceptor (US currency only)
- Internal heater
- Gate control
- Loop detector output
- Automated traffic light control
- Credit card reader (US and Canadian currency)

Consult for the following options

- Stainless steel enclosure
- Bar code badge scanner
- 230 VAC

Part Numbers/Price

Part #	Description	Price
119687	Weigh out kiosk with 920i® HMI and thermal kiosk printer, 24 × 24 × 12 in painted mild steel enclosure, A/D not included	\$6,695.00

Options/Accessories

Part #	Description	Price
119691	Vandal-proof 12-key keypad	\$505.00
176452	HID smart card reader	\$695.00
119692	88 key, panel mount Qwerty style keyboard	\$875.00
119693	200 watt heater	\$925.00
119761	Ethernet unmanaged switch, five port	\$315.00
119689	Kiosk option, A/D single-channel, includes DIN rail and terminals	\$395.00
119690	Kiosk option, A/D dual-channel, includes DIN rail and terminals	\$575.00
119946	Single port Ethernet server	\$485.00
120040	Dual port Ethernet server	\$675.00
33490	Relay rack four-channel Opto 22 style with screws	\$125.00
21159	Internal transient protection	\$245.00

Replacement Parts

Part #	Description	Price
105445	Paper 6 in OD, one ply thermal 80 mm (3.1 in) 710 ft/roll	\$30.00
105446	Paper 8 in OD, one ply thermal 80 mm (3.1 in) 1268 ft/roll	\$32.50
54215	3.15 amp 250V Slo Blo 5 x 20 mm kiosk power input fuse	\$5.00
160025	Power supply, IDEC 12V - 30W	\$185.00
88792	Power supply, IDEC 12VDC - 15W	\$140.00
88793	Power supply, IDEC 24VDC - 30W	\$230.00
72682	Network protection, surge	\$80.00
69201	RS-232 protection, TP232	\$187.00
181230	Serial kiosk printer kit (includes printer, bracket assembly, power supply and cables)	\$1,635.00
191359	Ethernet kiosk printer kit (includes printer, bracket assembly, power supply and cables)	\$1,695.00
179762	Direct thermal replacement RS232 printer, kiosk 80 mm DTL	\$1,175.00
203720	Direct thermal replacement TCP/IP printer	\$1,325.00

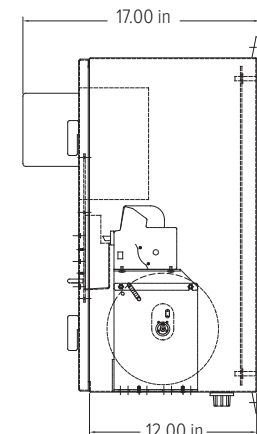
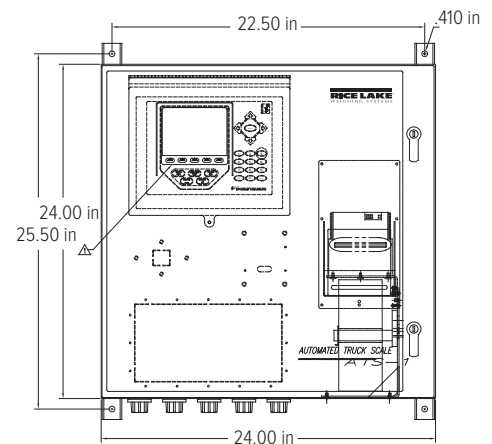

AUTOMATED
TICKETING

Weigh/Check In Kiosk

Automated Truck Scale System



Shown with PN 176452

Standard Features

Weigh/Check In Kiosk

- 920i® HMI with sun shield
- Four serial ports
- 120 VAC
- Two option slots for 920i option cards
- One-year warranty

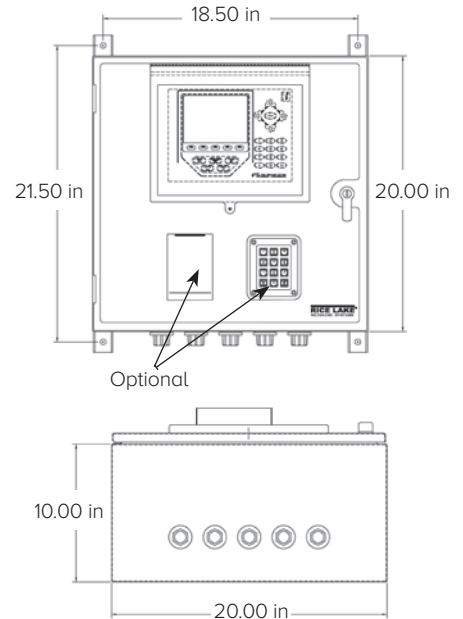

Part Numbers/Price

Part #	Description	Price
153353	Check-in kiosk with 920i HMI, 20 × 20 × 12 in painted mild steel enclosure	\$4,315.00

Options/Accessories

Part #	Description	Price
119691	Vandal-proof 12-key keypad	\$505.00
176452	HID smart card reader	\$695.00
119692	88 key, panel mount Qwerty style keyboard	\$875.00
119693	200 watt heater	\$925.00
119761	Ethernet unmanaged switch, five-port	\$315.00
119689	Kiosk option, A/D single-channel, includes DIN rail and terminals	\$395.00
119690	Kiosk option, A/D dual-channel, includes DIN rail and terminals	\$575.00
119946	Single port Ethernet server	\$485.00
120040	Dual port Ethernet server	\$675.00

AUTOMATED TICKETING

Printer Kiosk

Direct Thermal Printer Kiosk



PN 112836

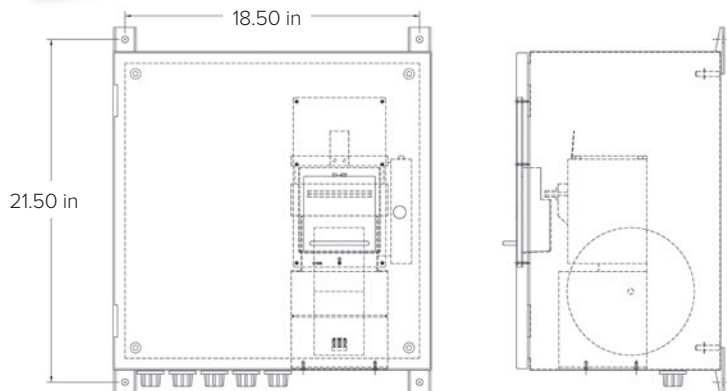

Standard Features

Direct Thermal Printer Kiosk

- Custom America VKP80II receipt printer
- Slide door access to ticket
- 8 in paper roll
- 1 year warranty

Specifications

Line Voltages:

115 or 230 VAC

Frequency:

50/60 Hz

Power Consumption:

0.5 amps (depending on options)

Fusing:

3.15 amps circuit breaker

Humidity:

0 to 95% relative humidity

Printer Communication Ports:

RS-232 or Ethernet

Storage Temperature:

14 °F to 158 °F (-10 °C to 70 °C)

Warranty:

One-year limited

Printer Kiosk

Thermal-transfer Printer Kiosk



Basic printer kiosk with optional RFID card reader and optional number keypad

Basic printer kiosk with optional RFID card reader



Basic printer kiosk PN 92971

Standard Features

Printer Kiosk with Ethernet Intercom

- Digital Acoustics Ethernet TCP/IP intercom substation
- Custom America VKP80III direct thermal printer

Thermal-transfer Printer Kiosk

- Painted mild steel enclosure
- Slide door access to ticket
- Zinc-plated 3/4-inch NPT conduit hubs
- Additional options available upon request

Note: Printer, thermal transfer ribbon and card stock sold separately

Specifications

Line Voltages:

115 or 230 VAC

Frequency:

50/60 Hz

Power Consumption:

0.5 amps (depending on options)

Fusing:

6 amp circuit breaker

Humidity:

0 to 95% relative humidity

Printer Serial Ports:

RS-232

Ethernet (optional)

Storage Temperature:

14 °F to 158 °F (-10 °C to 70 °C)

Current Supported Riser Plates:

Zebra® 140XIIIPlus

Zebra 105SL

Zebra R110Xi

Zebra Z4Mplus

Zebra 2746e

Honeywell 4206

Honeywell I-4212

Intermec/Honeywell 3400e

Intermec/Honeywell 4440

Warranty:

One-year limited

Part Numbers/Price

Part #	Description	Price
92971	Printer kiosk, inbound base unit 115 VAC (printer not included)	\$3,355.00
112836	Printer kiosk, thermal ticket printer 20 × 20 × 12 in painted mild steel enclosure	\$4,195.00
193639	Printer kiosk, thermal ticket printer (Ethernet), 20 × 20 × 12 in painted mild steel enclosure	\$4,355.00

A test plan is included with each kiosk.

Options/Accessories

Part #	Description	Price
119693	200 watt heater	\$925.00
119761	Ethernet unmanaged switch, five-port	\$315.00
119946	Single port Ethernet server	\$485.00
120040	Dual port Ethernet server	\$675.00
93463	Printer riser plate for Honeywell I-4212e	\$315.00
93468	Printer riser plate for Intermec/Honeywell 3400e	\$315.00
176452	HID smart card reader	\$695.00
131143	Honeywell I-4212e, direct thermal RS-232, parallel and USB	\$1,595.00
64884	Thermal transfer option Honeywell	\$133.00
131150	Ethernet option Honeywell	\$365.00
53918	Cutter option Honeywell	\$798.00
109298	Tag, direct thermal, 4 in wide, 7.2 pt continuous 480 ft roll	\$51.00
179762	Direct thermal replacement RS232 printer, kiosk 80 mm DTL	\$1,175.00
203720	Direct thermal replacement TCP/IP printer	\$1,325.00

Consumables

105445	Paper roll 6 in OD, one ply thermal 80 mm (3.1 in) 710 ft per roll	\$30.00
105446	Paper roll 8 in OD, one ply thermal 80 mm (3.1 in) 1268 ft per roll	\$32.50
89190	TT Tag stock 4 in wide, 7.5 pt continuous 400 ft roll	\$46.25
34056	Transfer ribbon, 4 in wide GPR Plus black 1181 ft roll	\$30.50

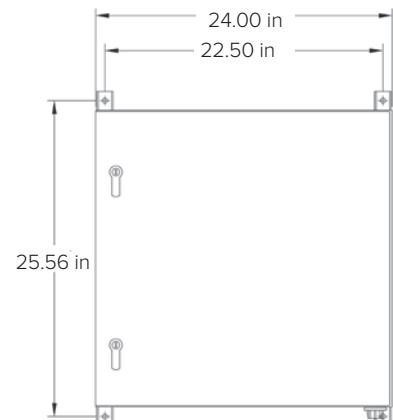
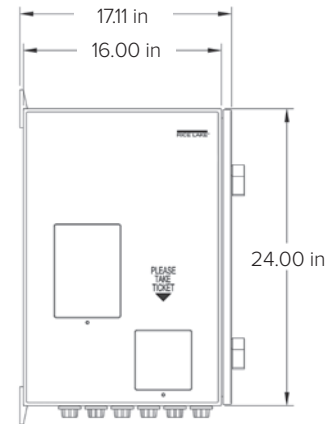

AUTOMATED
TICKETING

OnTrak® Enterprise

Truck Data Management Software



OnTrak® ENTERPRISE

TRUCK SCALE DATA MANAGEMENT

AUTOMATED
TICKETING

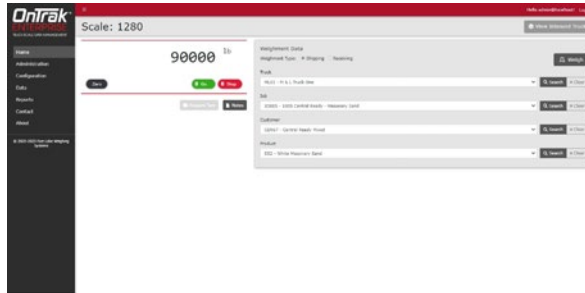

Weigh Screen

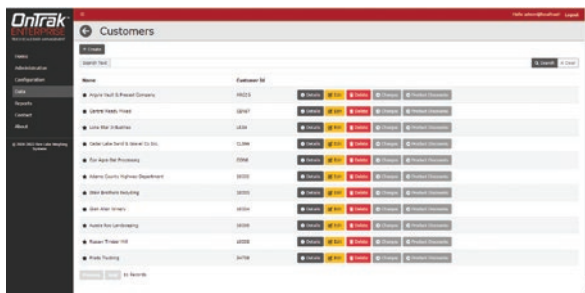

Customer Screen Main

Approvals



pending

Part Numbers/Price

Part #	Description	Price
218502	OnTrak Enterprise Base Software	\$3,495.00
Modules		
218503	License, Kiosk Module OnTrak Enterprise	\$795.00
218504	License, API Module OnTrak Enterprise	\$695.00
218505	License, Image Capture Module OnTrak Enterprise	\$695.00
218506	License, LPR Module OnTrak Enterprise, License Plate Recognition	Consult
Annual Maintenance Agreements (AMA)		
218507	OnTrak Enterprise AMA for Base Software	\$699.00
218508	OnTrak Enterprise AMA for Kiosk Module	\$159.00
218509	OnTrak Enterprise AMA for API Module	\$139.00
218510	OnTrak Enterprise AMA for Image Capture Module	\$119.00
218511	OnTrak Enterprise AMA for LPR Module	Consult

Note: Annual Maintenance Agreements (AMA) are required. Billable after year two.

Options/Accessories

Part #	Description	Price
Consult	Non-Rice Lake indicator interface	\$295.00
Consult	Custom reports	\$245.00/hour
104789	Phone Support, one hour	\$145.00

Standard Features

- Comprehensive transaction management
- Unlimited charge and discount amounts per product
- Calculates tax
- Ship or Receive mode for each transaction
- Assign one of four security levels to each user
- Exclusive databases for customer, hauler, truck, product, job, price/discount, tax and transaction
- Filter reports to view relevant information
- Customize printed tickets
- Back up and restore via SQL Server Management Studio available through Microsoft
- Software supports unlimited number of scales, number of scales supported is dependent on user's hardware
- Website for remote access, systems integration and data monitoring (SSL certificate required for publishing website to internet)
- A supported web browser (Google® Chrome®, Microsoft® Edge®, Mozilla® Firefox® or Apple® Safari®)

Optional Features

- 1280 kiosk interface
- REST API
- Image capturing*
- License plate recognition*

Specifications

Systems Requirements:

Windows® 10 or newer (x64 systems)

Databases:

10 GB max database size when using included Microsoft SQL Server Express

*Unlimited database size when using a purchased edition of Microsoft SQL Server (required when using image capturing or license plate recognition)

Communications:

Supports all Rice Lake indicator interfaces and 1280 based Automated Ticketing Kiosks
Optional drivers available for non-Rice Lake weight indicators (Ethernet TCP/IP required)

Transaction Ticket:

User defined ticket formatting

Export Data:

File export of completed transactions via: XML, JSON, CSV or TXT

Software Support:

Database configuration, field installation and training available
Phone support packages available
Contact Rice Lake for further options

Approvals:

NTEP 05-107 (pending)

OnTrak®

TRUCK SCALE DATA MANAGEMENT

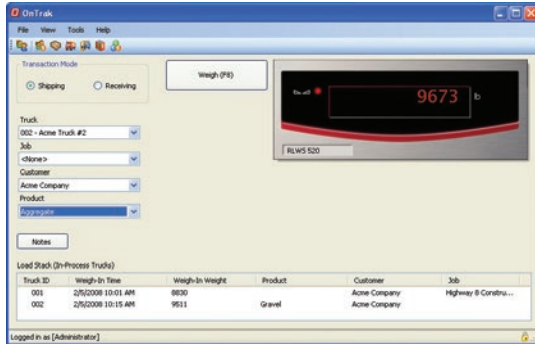

Weigh Scale

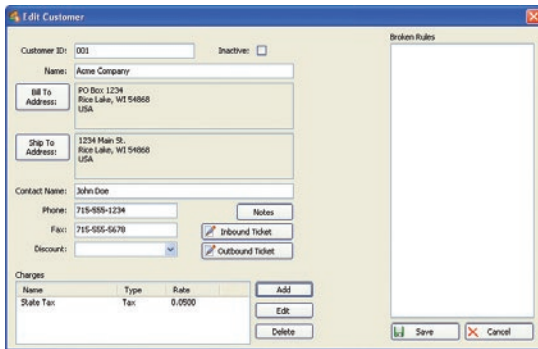

Customer Account Information

Approvals



Part Numbers/Price

Part #	Description	Price
104787	OnTrak activation code	\$1,495.00
101062	OnTrak CD-ROM	\$84.00

OnTrak trial at www.ricelake.com/ontrak

Options/Accessories

Part #	Description	Price
Consult	Non-Rice Lake indicator interface	\$245.00
Consult	Custom reports	\$243.00/hour
Consult	Database configuration	\$243.00/hour
FLD-INSTALL	Field installation	\$1,395.00/weekday plus expenses
104789	Phone support, one hour	\$145.00
101003	Additional OnTrak manual	\$65.00

Standard Features

- Supports systems using Windows® 10 and newer
- Microsoft SQL Server Express client/server database (free edition)
- Comprehensive report filters
- User and administrator roles
- Back up and restore via SQL Server Management Studio freely available through Microsoft
- Unlimited charge/discount per product
- Ship or Receive mode for each transaction
- Exclusive database for: customer, hauler, truck, product, job, price/discount, tax, transaction
- Ethernet TCP/IP or RS-232 connectivity
- Supports VIRTUi/VIRTUi2® or Rice Lake weight indicators
- CSV transaction file export
- Supports one or two scales

Optional Features

- Image capture with Ethernet camera TCP/IP (requires SQL Server Standard or better through Microsoft)
- Interface to non-Rice Lake weight indicators
- Custom reports
- Database configuration
- Field installation and training
- Factory phone support

Specifications

System Requirements:

Windows® 10 and newer (x64 systems)

Databases:

10 GB max database size when using included Microsoft SQL Server Express
 Unlimited database size when using a purchased edition (contact Microsoft for details on purchasing a licensed edition of SQL Server)

Communications:

Support for multiple printers
 Supports all Rice Lake indicator interfaces
 Supports VIRTUi/VIRTUi2 interface
 920i based Automated Ticketing Kiosks
 Optional drivers available for non-Rice Lake weight indicators

Transaction Ticket:

User defined ticket formatting

Reports:

Comprehensive report filters
 Optional custom reports

Export Data:

File transfer via XML transaction; exported reports can be saved as PDF/XLS; configurable transaction data export in CSV file format

Transaction Calculations:

Unlimited product prices and discounts
 Tax calculations (does not integrate directly to financial software)

Software Support:

Database configuration, field installation and training available
 Phone support packages available
 Contact Rice Lake for further options

Approvals:

NTEP 05-107

AUTOMATED TICKETING

Kiosk Safety Swing-away Arm

Self Centering Kiosk Mount



Standard Features

- Protects kiosk from vehicle traffic
- Swings away freely and returns to center position
- Universal mount accommodates a wide variety of kiosks
- Includes mounting pole and base stand
- Adjustable vertical and horizontal mounting

AUTOMATED
TICKETING

Part Number/Price

Part #	Description	Price
109164	Complete kit for pit type scale (10 ft pole, red paint)	\$1,645.00
109163	Complete kit for aboveground scale (12 ft pole, red paint)	\$1,675.00
105939	Weldment, swing arm, kiosk (red)	\$895.00
105941	Pole weldment, 10 ft supported/free standing, 4.5 in outer dimension (red paint)	\$695.00
105940	Pole weldment, 12 ft supported/free standing, 4.5 in outer dimension (red paint)	\$775.00
110606	Weldment, swing arm 24 × 24 × 16 in side discharge printer kiosk (red paint)	\$895.00
155435	Weldment, swing arm 30 × 24 × 16 in side discharge printer kiosk (red paint)	\$1,145.00
178074	Complete kit for pit type scale (10 ft pole, yellow paint)	\$1,645.00
178073	Complete kit for aboveground scale (12 ft pole, yellow paint)	\$1,675.00
178077	Pole weldment, 10 ft supported free standing 4.5 in outer dimension (yellow)	\$695.00
178076	Pole weldment, 12 ft supported free standing 4.5 in outer dimension (yellow)	\$775.00
178075	Weldment, swing arm kiosk (yellow)	\$895.00
160403	Mount, swing arm pole for SURVIVOR ATV truck scale	\$1,295.00

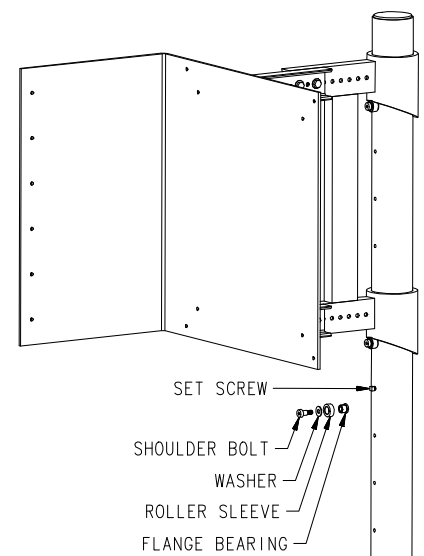
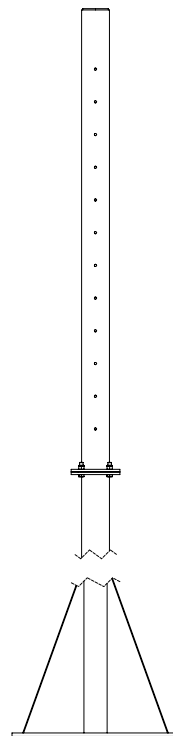
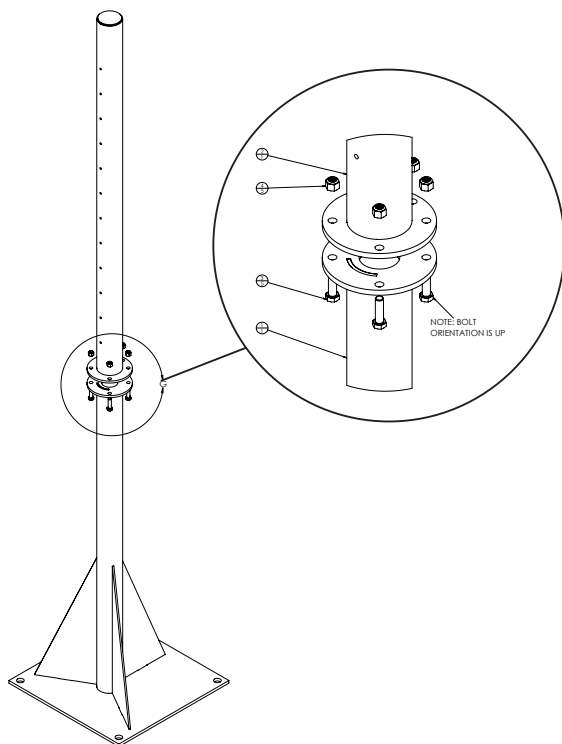

Kiosk Safety Swing-away Arm

Self Centering Kiosk Mount

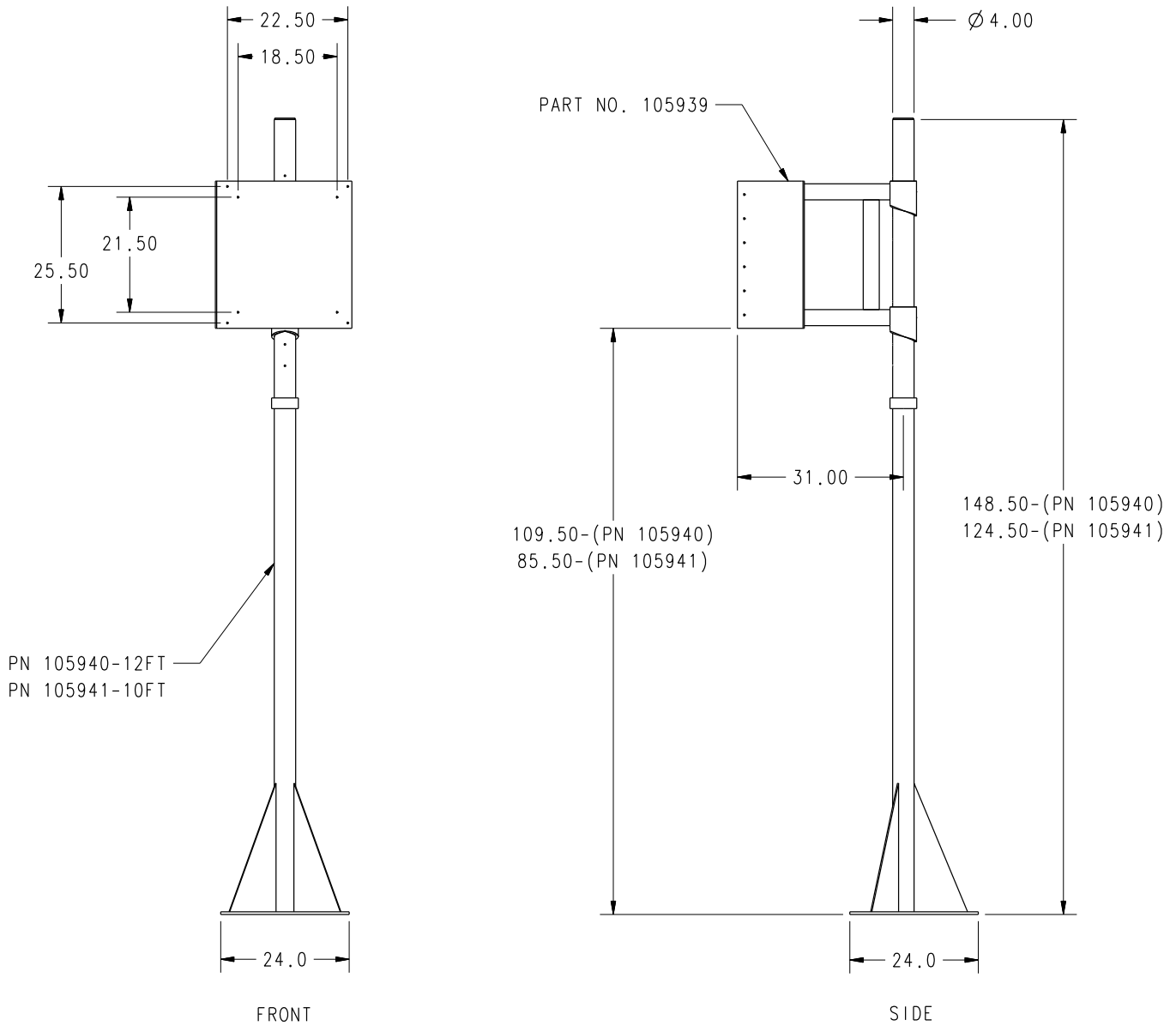

**AUTOMATED
TICKETING**

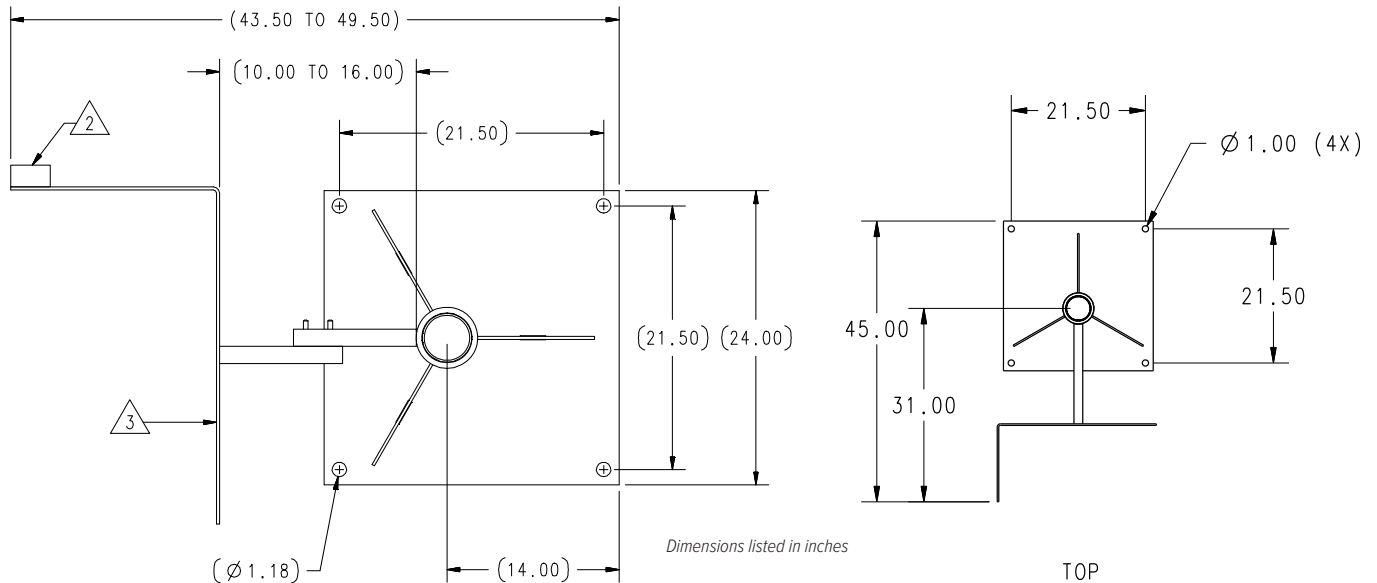

Vehicle Loop Detector



Standard Features

Vehicle Loop Detector

- Loop diagnostics
- Loop isolation transformer
- Loop conditioner
- Aluminum RF shield housing
- Surge protection
- Loop frequency counter
- 10 gold-plated sensitivity controls
- Eight gold-plated function controls
- Six gold-plated controls for frequency, reset and frequency counter
- Two high-intensity LED indicators
- Two relays—relay 2 is pulse or presence

Specifications

Vehicle Loop Detector Power:

The detector is available in the following voltages:
12 VAC/DC, 24VAC, 24VDC, 110 VAC, 220 VAC
Maximum current draw 100mA

Low Power:

Detector is available with maximum current draw of 60mA

Operating Temperature:

-40 °F to 180 °F (-40 °C to 82 °C)

Enclosure:

Extruded anodized aluminum
(L × W × H)
3.25 × 2.56 × 3.65 in
(83 × 40 × 90 mm)

Output Relays:

5A/125 VAC standard version, 1A/125 VAC
low current version

Connector:

86CP11 compatible with 11-Pin Octal DIN-rail
mountable socket or wire harness

Overall Diameter of Loop Wire:

0.26 in

Loop Dimensions:

4 × 6 ft thru 4 × 12 ft standard,
custom sizes available

Lead-in-Wire:

50 ft long, twisted wire in PVC jacket

Loop Wire Approvals:

UL subject 13, Type PLTC 300V, 90C passes IEEE-
328,210,000, BTU Flame Test
Pennsylvania, Bureau of Deep Mine Safety,
Approval P-MWMS-1-85

Part Number/Price

Part #	Description	Price
Consult	Relay box for additional I/O control	Consult
171093	Vehicle Detector includes pre-wired loop detectors, terminals for wiring lead wires from loops and power source. (loops not included)	\$1,355.00
78986	Loop, vehicle detection preformed, 4 ft x 8 ft loop, 50 ft lead in wire	\$275.00
86758	Loop, vehicle detection preformed, 4 ft x 10 ft loop, 50 ft lead in wire	\$275.00

AUTOMATED
TICKETING

EMX Lite Preformed Loops®



Standard Features

EMX Lite Preformed Loops

- Rugged and flexible TPE tubing
- Electronic lightning protection of vehicle detectors
- Comes standard with 50 ft of twisted and jacketed lead-in wire
- Vehicle detection loop is constructed of stranded wire conductors with thermoplastic elastomer insulation jacketing
- Outer shell is flexible nonmetallic 0.26 in tubing
- Two relays—relay 2 is pulse or presence
- Loop installation requires backer rod and epoxy sealant provided by others

Specifications

Vehicle Loop Detector Power:

The detector is available in the following voltages:
12 VAC/DC, 24VAC, 24VDC, 110 VAC, 220 VAC
Maximum current draw 100mA

Low Power:

Detector is available with maximum current draw of 60mA

Operating Temperature:

-40 °F to 180 °F (-40 °C to 82 °C)

Enclosure:

Extruded anodized aluminum
(L × W × H)
3.25 × 2.56 × 3.65 in
(83 × 40 × 90 mm)

Output Relays:

5A/125 VAC standard version, 1A/125 VAC
low current version

Connector:

86CP11 compatible with 11-Pin Octal DIN-rail
mountable socket or wire harness

Overall Diameter of Loop Wire:

0.26 in

Loop Dimensions:

4 × 6 ft thru 4 × 12 ft standard,
custom sizes available

Lead-in-Wire:

50 ft long, twisted wire in PVC jacket

Loop Wire Approvals:

UL subject 13, Type PLTC 300V, 90C passes IEEE-
328,210,000, BTU Flame Test
Pennsylvania, Bureau of Deep Mine Safety,
Approval P-MWMS-1-85

Part Number/Price

Part #	Description	Price
86601	Vehicle detector includes detector, socket and 4 ft x 8 ft loop with 50 ft lead in wire	\$655.00
86759	Vehicle detector includes detector, socket and 4 ft x 10 ft loop with 50 ft lead in wire	\$655.00



Standard Features

TransCore SmartPass® RFID Reader

- Fully self-contained, integrated reader
- Ideal for truck scales, and parking and access control applications
- 915 MHz RF band operation
- Compatibility with a wide range of industry-standard formats
- Weatherproof enclosure
- Quick, simple installation by trained, authorized personnel
- Programmable RF power
- Compatible with a variety of RFID tag options including half and full frame RFID tags (beam or battery powered) as well as windshield RFID tag options (beam or battery powered)

Specifications

Frequency Range:

902 to 928MHz

RF Control:

By sense output or host command

Polarization:

Linear, horizontal

Read Range:

Read performance varies depending on tag and reader configuration and environment
Read range for all the SmartPass E4 Reader is 12 ft (3.7 m) typical to 17 ft (3.7 m) maximum

I/O Control:

Input: Two independent dry contact closures for sense circuits

Output: Two independent Form-C contacts

Dimensions:

(L x D x W)
15.5 x 15.5 x 3.25 in
(393 x 393 x 83 mm)

Weight:

9.5 lb (4.3 kg)

Mounting Surface:

Mount to pole or wall, indoor or outdoor

Enclosure:

Tamper-proof, polycarbonate housing

Operating Temperature:

-40 °F to 131 °F (-40 °C to 55 °C)

Humidity:

100% condensing

Vibration:

0.5 grams, 10 to 500 Hz

Input Power:

16 to 20 VAC, 47 to 63 Hz, or 16 to 28 VDC

Part Number/Price

Part #	Description	Price
108201	SmartPass E4 reader only	\$6,725.00
162431	18 VAC power supply	\$47.00
86401	5 ft interface cable	\$165.00
162430	20 ft interface cable	\$330.00
86403	35 ft interface cable	\$490.00
162432	Pole/wall mount bracket	\$145.00

AUTOMATED
TICKETING

Multiprotocol Rail Reader and Parapanel Antenna



Standard Features

Multiprotocol Rail Reader

- Designed for railroad applications
- Fixed mount, integrated package (reader and RF module)
- Reads Association of American Railroads (AAR) format tags and Suer eGo® (SeGO) protocol tags
- Supports tag and mutual authentication
- 902 to 928 MHz RF range operation in North America
- Real-time clock
- Tag read buffering
- Programmable RF output power
- Programmable frequency
- Supports up to two AT5720 Check Tags
- Multiplexes up to four antennas

Parapanel Antenna

Standard Features

- Asymmetrical broadcast pattern
- Low-profile design
- Weatherproof enclosure
- UV-tolerant and corrosion-resistant construction

Part Number/Price

Part #	Description	Price
Consult	Please consult sales engineer to ensure proper system for application	Consult

RFID Access Tags

AUTOMATED TICKETING



157184



157185

Standard Features

RFID Access Tags

- Interior mounting on non-metallized windshield
- Impact resistant, molded plastic case
- Slim profile
- Non-battery for extended service life (AT5402)
- Dual-frequency (915 and 2450 MHz, AT5406)

Specifications

Frequency Range:

AT5402: 902 to 928 MHz
AT5406: 902 to 928 MHz/2425 to 2475 MHz

Typical Working Range with TransCore Encompass® 4:

AT5402: 5 to 10 ft (1.5 to 3 m)
AT5406: 5 to 35 ft (1.5 to 11 m)

Polarization:

Parallel with longer side

Data Capacity:

Up to 10 alphanumeric characters (60 available bits) or Wiegand 26 to 54 bit formats

Power Source:

AT5402: Beam-powered
AT5406: Lithium battery

Dimensions:

(L × W × H)
AT5402: 3.60 × 2.30 × 0.27 in
(92 × 59 × 7 mm)
AT5406: 4.50 × 2.50 × 0.70 in
(114 × 64 × 18 mm)

Weight:

AT5402: 1.4 oz. (40 g)
AT5406: 3.5 oz. (99 g)

Service Life:

AT5402: >10 years
AT5406: Eight-year lithium battery (typical life)

Case Material:

Weatherproof, polycarbonate alloy, UV stabilized

Mounting Surface:

Interior: Non-metallic windshield

Mounting Method:

Semi-permanent mounting: Double-sided tape
Removable mounting: Adhesive-backed hook-and-loop material attached to the tag and vehicle windshield

Operating Temperature:

-40 °F to 185 °F (-40 °C to 85 °C)

Part Number/Price

Part #	Description	Price
157184	AT5402 windshield tag beam power	\$42.00
157185	AT5406 windshield tag with battery	\$58.00
159518	Programming fee	\$310.00

Note: Programming fee applies if ordering fewer than 100 tags

RFID Transportation Tags



Standard Features

RFID Transportation Tags

- Harsh environment durability
- Factory sealed case
- Non-battery for extended service life (AT5412)
- Dual-frequency (915 and 2450 MHz, AT5414)

Specifications

Frequency Range:

AT5412: 902 to 928 MHz
AT5414: 902 to 928 MHz/2425 to 2475 MHz

Typical Working Range with TransCore® Encompass 4:

AT5412: 5 to 10 ft (1.5 to 3 m)
AT5414: 5 to 35 ft (1.5 to 11 m)

Polarization:

Parallel with longer side

Data Memory Capacity:

SeGo and eGo Modes: 2048 bits
ATA Mode: 60 bits

Power Source:

AT5412: Beam
AT5414: Lithium battery for a typical eight-year life

Dimensions:

(L × W × H)
AT5412: 9.30 × 2.38 × 0.69 in
(236 × 60 × 18 mm)
AT5414: 9.32 × 2.39 × 0.75 in
(237 × 61 × 19 mm)

Weight:

AT5412: 5.3 oz (150.2 g)
AT5414: 6.6 oz (187 g)

Case Material:

Weatherproof, polycarbonate, UV-stabilized case that is sealed after programming

Mounting Surface:

Any smooth metallic surface

Mounting Method:

Mount to any flat smooth metal surface using bolts, screws or blind rivets

Operating Temperature:

-40 °F to 185 °F (-40 °C to 85 °C)

Part Number/Price

Part #	Description	Price
86399	AT5412 transportation tag 1/2 frame beam power	\$63.00
157188	AT5414 transportation tag 1/2 frame with battery	\$79.00
159518	RFID programming tag	\$310.00

Note: Programming fee applies if ordering less than 100 tags

HID RFID Cards



Standard Features

HID RFID Cards

- Offer sufficient read/write memory to store multiple biometric templates
- Available in a 2 or 16 application area configuration
- Offer multiple, securely separated areas to enable numerous applications, including the HID standard access control application
- Future growth for new read/write applications
- ISO 15693 and 14443B2 standards for read/write contactless communication
- Cost-effective way to enhance the security of your access control installation
- Close range

HID RFID Readers

AUTOMATED
TICKETING



Standard Features

HID RFID Readers

- More powerful and versatile access control
- User-friendly proximity technology
- Uses the 13.56 MHz technology platform
- High-intensity, three-color light bar provides clear, visual feedback, even in direct sunlight
- Selectable, distinct tone sequences indicate status conditions
- All RF data transmission between the card and reader is encrypted using a secure algorithm
- Close range

Specifications

Typical Maximum Read Range*:

- 2.5 to 4.5 in (6.3 to 11.4 cm) with HID iCLASS® card
- 1.0 in (2.5 cm) with HID iCLASS key
- 1.0 in (2.5 cm) with HID iCLASS tag
- 1.5 to 2.0 in (3.8 to 5.0 cm) with HID iCLASS prox
- 1 to 2 in (2.5 to 5.0 cm) with MIFARE® card (serial number only)

*Using ISO 15693 mode (except MIFARE®). Dependent upon installation conditions. Please note that all iCLASS credentials are available in either a 2K bits (256 Bytes) or 16Kbits (2 KBytes) configuration.

Dimensions:

- (L × W × H)
- 3.30 × 0.85 × 4.80 in
- (84 × 22 × 122 mm)

Material:

UL94 polycarbonate

Power Supply:

10 to 16VDC reverse voltage protected
Linear supply recommended

Current Requirements (Avg/Peak):

80/260mA at 12VDC

Operating Temperature:

-31 °F to 150 °F (-35 °C to 65 °C)

Operating Humidity:

5 to 95% relative humidity non-condensing

Weight:

8.8 oz (249.5 g)

Transmit Frequency:

13.56 MHz

Cable Distance:

Wiegand interface: 500 ft (150 m)
Recommended cable is ALPHA 1295 (22AWG)
Five-conductor stranded with overall shield or equivalent. Additional conductors may be required to connect all outputs.

Pending Certifications:

Taiwan, Singapore, Germany VdS

Approvals:

UL 294/cUL
FCC Certification
Canada Certification
CE Mark (Europe)
New Zealand
Australia c-Tick

Part Number/Price

Part #	Description	Price
176452	HID smart card reader, includes Wiegand to RS232 converter and mounting hardware	\$695.00
88792	Power supply, IDEC 12VDC output, 85 VAC input, required for 176452 above	\$140.00
85902	iClass Smart Card pack 1 to 25 13.56 MHz	\$155.00
85903	iClass Smart Card pack 26 to 50 13.56 MHz	\$155.00
85904	iClass Smart Card pack 51 to 75 13.56 MHz	\$155.00
85905	iClass Smart Card pack 76 to 100 13.56 MHz	\$155.00
95358	Card, HID unprogrammed configured 256 byte no slot punch - MUST BE FACTORY PROGRAMMED	\$8.50
212168	Card, HID unprogrammed configured 256 byte vertical slot	\$10.00

Keyfob and disc tags optional—consult for price.



HID card (PN 212168)

Remote HID Box

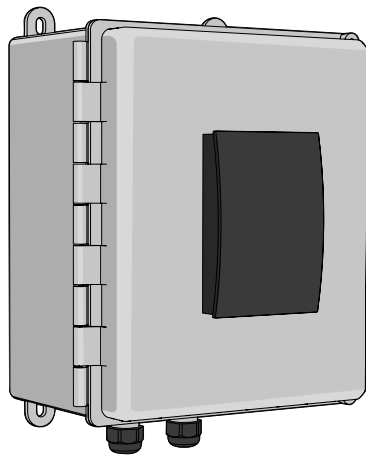

AUTOMATED
TICKETING

Standard Features

- Self-contained HID reader with Weigand to RS-232 converter with power supply
- Indoor/outdoor
- Use with 920i, 1280 indicators and kiosk systems
- Requires special programming

Specifications

Typical Maximum Read Range*:

- 2.5 to 4.5 in (6.3 to 11.4 cm) with HID iCLASS® card
- 1.0 in (2.5 cm) with HID iCLASS key
- 1.0 in (2.5 cm) with HID iCLASS tag
- 1.5 to 2.0 in (3.8 to 5.0 cm) with HID iCLASS prox
- 1 to 2 in (2.5 to 5.0 cm) with MIFARE® card (serial number only)

*Using ISO 15693 mode (except MIFARE®).

Dependent upon installation conditions. Please note that all iCLASS credentials are available in either a 2 K bits (256 Bytes) or 16Kbits (2 KBytes) configuration.

Dimensions:

(L × W × H)
10.50 × 8.91 × 6.25 in
(267 × 226 × 159 mm)

Material:
FRP

Specifications Continued

Power Supply:

120 VAC input @ 10W, 5 VDC Output 2 @ Amp

Current Requirements (Avg/Peak):

80/260mA at 12 VDC

Operating Temperature:

-31 °F to 150 °F (-35 °C to 65 °C)

Operating Humidity:

5 to 95% RH (non-condensing)

Weight:

8.8 oz (249.5 g)

Transmit Frequency:

13.56 MHz

Cable Distance:

RS-232-C 50 ft

Pending Certifications:

Taiwan, Singapore, Germany VdS

Approvals Power Supply:

CE Marked
TUV
UL61010/cUL
CSA C22.2 o. 1071
UL1604: Class I Div 2
EN 50175
LVD: EN662368
EMC: Directive EN61204-3
EMI: Class B, EMS Industrial

Pending Approvals HID:

Taiwan, Singapore, Germany VdS

Approvals HID:

UL 294/cUL
FCC Certification
Canada Certification
CE Mark (Europe)
New Zealand
Australia c-Tick

Part Number/Price

Part #	Description	Price
220144	HID Box, remote	\$1,455.00

HID Long Range Readers



Standard Features

- Discreet hands-free authentication solution for long range parking, gate control and truck identification
- IP65 rating allows outdoor mounting
- Supports Wiegand standards
- Requires Wiegand converter, consult with a sales engineer with application specifics

Specifications

Dimensions:

(L × W × H)
9.10 × 9.10 × 2.75 in
(231 × 231 × 70 mm)

Color:

Black

Mounting:

Drill mounting box to meet application
Drill points provided for US and EU wall boxes, and 75 mm, 100 mm and 200 mm VESA mounts

Storage Temperature:

-67 °F to 185 °F (-55 °C to 85 °C)

Operating Temperature:

-30 °F to 150 °F (-35 °C to 65 °C)

Operating Humidity:

5% to 95% relative humidity non-condensing

Rating/Material:

IP65
UL94 Polycarbonate

Typical Maximum Read Range:

9.8 to 16.4 ft
(3 to 5 m) (Mexico)

Transmit Frequency:

865 to 868 MHz / 902 to 928 MHz
dependent on regional regulations

Approvals:

UL 294/cUL, CB Scheme
FCC Certification
IC (Canada)
CE (Europe)
IFETEL (Mexico)

Part Number/Price

Part #	Description	Price
184458	Reader, long range HID	\$1,695.00
184459	UHF credentials (factory programming required)	\$15.00
184466	Windshield mount	\$10.50
220769	Convertor, Weigand/RS232I	\$1,025.00

TagMaster CT-45

Network IP Camera with License Plate Recognition (LPR)



Standard Features

- Compatible with OnTrak® Enterprise
- Plate localization, country and state identifiers
- Optical Character Recognition (OCR) Library
- Number and letter segmentation
- Works in daylight and low-light conditions
- Operating range, 10 to 82 ft (3 to 25 m)

Specifications

Read Range:
10 to 82 ft (3 to 25 m)

Image Sensor:
2 megapixels
1/2.8 in CMOS sensor

Frame Rate:
25 FPS

Interface:
LAN (weatherproof standard RJ-45) 10/100 Mbps
Ethernet interface Wi-Fi (for easy setup)
Relay Control (1 input, 2 outputs) Wiegand

Specifications Continued

Power Input/Network:
24 to 48 VDC, PoE+ IEEE 802.3 at
Requires CAT 5e or better network, POE+ network
switch or 24-48 VDC power supply

Power Consumption:
Average 18W, max 25W

Dimensions:
4.0 × 7.0 × 11.5 in
(102 × 180 × 290 mm)

Weight:
6.5 lb (2.95 kg)

Rating:
IP66

Operating Temperature:
-40 °F to 140 °F (-40 °C to +60 °C) 0% to 95% RH

Approvals:
IEC 62368-1, Electrical Safety General
IEC 60950-22, Electrical Safety Outdoor
IEC 62471, Photobiological
EN 55022:2010, Emissions
EN 55024:2010, Immunity
IEC 60068-2-27 Ea, Shock
IEC 60068-2-64 Fh, Vibration
UL94 HB, Flammability
RoHS directive 2002/95/EC and RoHS2 directive
2011/65/EU

Part Number/Price

Part #	Description	Price
220688	Camera LPR	\$8,045.00
220690	Mounting bracket, LPR camera	\$245.00
220691	Cable power & relay LPR camera power cable	\$125.00

AUTOMATED
TICKETING

Vivotek IP8361

Network IP Outdoor Camera



Standard Features

- Compatible with OnTrak® Enterprise
- Includes motion detection
- Remotely pan and tilt camera horizontally and vertically
- IR night vision makes images clear even in the dark
- Operating range, 10 to 82 ft (3 to 25 m)

Specifications

Read Range:
10 to 82 ft (3 to 25 m)

Interface:
10Base-T/100 Base TX Ethernet (RJ-45)

Power Input:
IEEE 802.3af PoE Class 3

Power Consumption:
Max. 7.2 W (PoE)

Dimensions:
3.3 × 8.3 in
(83 × 212 mm)

Operating Temperature:
-4 °F to 122 °F
(-20 °C to 50 °C)

Weight (including bracket):
3.5 lb (1.6 kg)

Rating:
IP66

Approvals:
CE
LVD
FCC Class A
VCCI
C-Tick

Part Number/Price

Part #	Description	Price
163175	Ethernet camera 2-megapixel CMOS sensor	\$1,500.00
131605	Power supply, POE injector	\$205.00
15438	Power cord	\$25.00

Photo Eyes



Retro-reflective

Standard Features

- Many varieties available for both truck scale and dynamic weighing applications
- Arrange photo eyes to keep wheels on scale
- Rugged outdoor applications
- Reflective types work up to 17 ft (5.18 m) in clean conditions
- Quick disconnects for easy replacement
- Broken beams can signal a wheel off the scale or prevent a weighment in unattended systems
- Transmitter/receiver types work up to 17 ft in clean conditions

AUTOMATED TICKETING

Part Number/Price

Part #	Description	Price
Photo Eyes		
78975	Allen-Bradley® photo eye retro-reflective sensor	\$340.00
78976	Photo eye reflector, 3 in diameter	\$29.00
78977	Quick disconnect photo eye cable, 12 ft, 5-Pin mini connector	\$145.00
Photo Switches		
165776	Kit, photo eye switch	\$1,395.00
103013	Photo switch receiver	\$300.00
103014	Photo switch transmitter	\$225.00
196361	Photo switch transmitter (DC)	\$265.00
103015	Photo switch quick connector receiver	\$145.00
103016	Photo switch quick connector transmitter	\$115.00
130398	Mounting swivel assembly for 103013 and 103014	\$31.00
156532	Photo eye stand kit	\$425.00



Photo eye stand

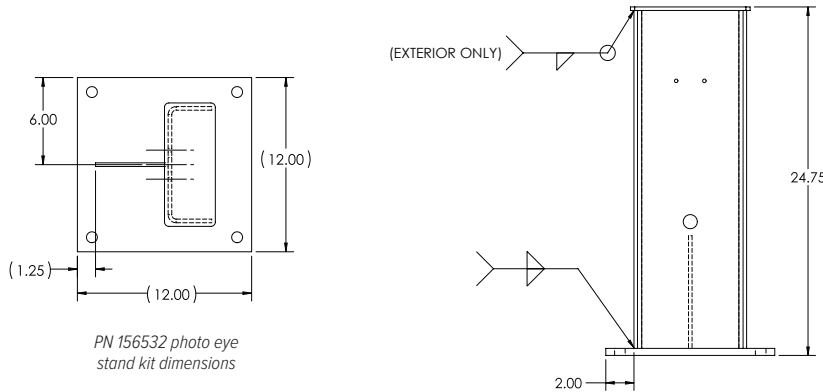

PN 156532 photo eye stand kit dimensions

Dimensions listed in inches

Traffic Light Kits



Traffic Light

Standard Features

Light

- Housing meets or exceeds ITE specifications
- Stainless steel hardware
- 8 in LED lights, enclosure injection molded polycarbonate
- LED modules
- Compliant to ITE UTCSH - LED circular signal
- Temperature compensated power supplies for long LED life
- Conformal coated power supplies
- Intertek/ETL certified and listed on ETL certification program
- 135 VAC

Pole

- 4.5 in outer dimension aluminum pole
- Cast aluminum base mounts to concrete with four anchor bolts
- Base underside has integrated anchor bolt guide to ensure proper anchor placement.
- Removable 8 in access door for cable splicing and bolt attachments (H x W) 15 x 13-3/4 in

AUTOMATED TICKETING

Part Number/Price

Part #	Description	Est. Weight	Price
23146	2 Section, With Mounting Hardware for 4.5 Inch Pole 120VAC LED	25 lb	\$865.00
85789	Kit, traffic light pole. Includes 8 ft aluminum pole, base & four 18 in anchors. Bolts with nuts and washers. Option: Pole cap (PN 179172)	70 lb	\$1,055.00
179172	Aluminum pole cap, 4.5 in (for use when traffic light not mounted on pole)	-	\$59.00
87111	Side mount brackets include 12 in nipples and universal hubs, bracket, aluminum upper and lower assembly	10 lb	\$240.00
84504	Anchor bolt with nut washer	2 lb	\$13.00
160242	Kit; dual traffic light	-	\$5,395.00
160208	Control panel, dual traffic light	-	\$975.00
156106	Buzzer box, 115 VAC	-	\$795.00
163734	Switch box, remote (includes legend plates for Zero, Print, Tare, Cancel and Accept)	-	\$315.00



Anchor bolt with nut and washer



Side Mount Brackets

Traffic Light Pole



Control Panel



Buzzer Box



Switch Box



Scale Intercom



Standard Features

- Moisture and puncture resistant speaker
- Three-layer steel baffle protects speaker from tampering
- Hands-free communication
- Weather and vandal resistant
- FRP enclosure

Specifications

Wiring:

CAT5 to Ethernet adapter

Dimensions:

(L × W × H)
14 × 12 × 8 in

Communication:

PC software functions as base station for networked intercom system

TalkMaster FOCUS, download directly from digitalacoustics.com/talkmaster-focus-software-download/

AUTOMATED TICKETING

Part Number/Price

Part#	Description	Price
215451	Ethernet intercom	\$2,625.00

Ethernet Serial Servers



Part Number/Price

Part#	Description	Price
221451	Ethernet serial server dual serial port (two-terminal blocks) one Ethernet 10/100 (RJ45) DIN rail mounting	\$875.00
197373	Ethernet serial server four serial port (DB-9) one Ethernet 10/100 (RJ45) DIN rail mounting	\$1,000.00