

Paramounts

WEIGH MODULE
SYSTEM

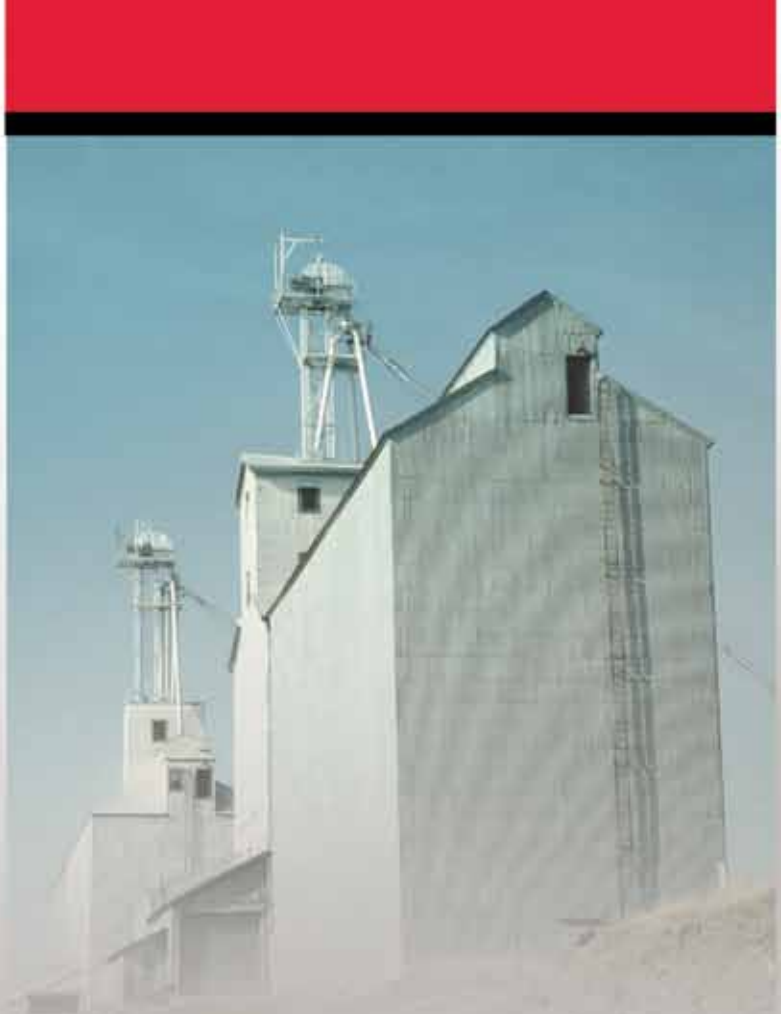

RICE LAKE[®]
WEIGHING SYSTEMS

To be the best by every measure[®]

800-472-6703

www.ricelake.com
m.ricelake.com

Paramounts WEIGH MODULE SYSTEM

The Paramounts system offers superior accuracy in applications with extreme expansion, contraction and vibration. The fixed-pin module acts as the vessel's primary reference point, enabling rotation. A single side-stop module is paired with the fixed-pin module to permit mechanical expansion and contraction in one direction. With the addition of one to six free-sliding modules, the vessel then becomes a high-accuracy weighing device. This system offers the free motion necessary to eliminate unwanted mechanical side loads, as well as the strength needed to keep the vessel in check.

Integral jacking/shipping bolts enhance safety by preventing accidental lift-off, facilitating quick field removal of load cells and eliminating load cell damage during transportation. Matched load cell electrical outputs and field-replaceable cables simplify installation and enhance serviceability.

As a system, Paramounts represents the ultimate combination of convenience, accuracy and control. The Paramounts system includes load cells, mounting assemblies, junction box and cable, providing everything needed to convert any weight into a readable, formattable electronic signal.

Standard Features:

- Capacities per assembly: 520lb-22,500lb
- SB5 environmentally sealed stainless steel load cell
- Weigh modules mild or stainless
- Blind load-hole design isolates load cell from unwanted extraneous forces
- Hermetically-sealed stainless-steel load cells offer unparalleled durability
- Low-profile, self-checking design offers superior versatility and eliminates extra hardware
- Jacking screw allows empty vessel to be lifted clear of load cell for maintenance
- Vessel is free to slide laterally on PTFE-coated surfaces minimizing errors caused by thermal expansion/contraction
- Load cell outputs are matched to $\pm 0.07\%$ for ease of installation and maintenance
- 520lb capacity using the Flintec SB10 load cell
- 30ft cables standard on all capacities except 520lb (10ft)

Typical Mounting Configurations:

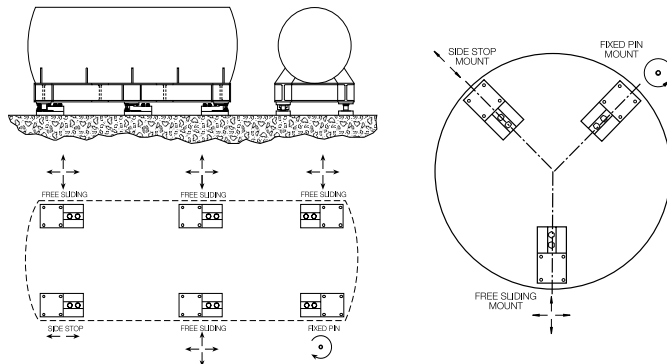

Rectangular & Cylindrical Vessel Arrangements

Capacities/Dimensions:

Mild Steel Construction—capacities per assembly: 520lb, 1,125lb, 2,250lb, 5,200lb, 11,250lb, 22,500lb

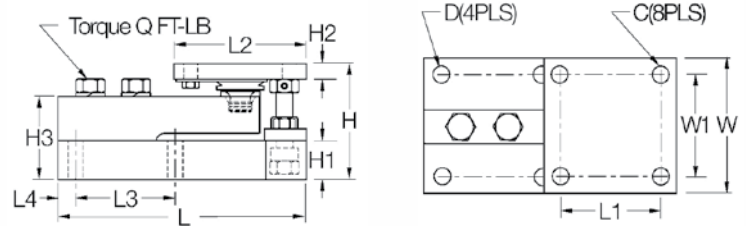

Options:

- Paramounts EP utilize the Flintec SB5 environmentally sealed stainless steel load cell and the Paramounts HS and HE utilize the Flintec SB4 hermetically sealed stainless steel load cell
- Paramounts HE stainless steel mounts and load cells
- NTEP-certified load cells available; capacities per assembly 1125lb-11,250lb
- Stainless steel SURVIVOR® systems available for hostile environments

Dimensions Inches (mm)	520lb (236.1 kg)	1125-5200lb (510.8-2360.0 kg)	11,250lb (5107.5 kg)	22,500lb (10,215.0 kg)
C	.375 (9.5)	.437 (11.1)	.562 (14.3)	.688 (17.5)
D	.437 (11.1)	.437 (11.1)	.562 (14.3)	.688 (17.5)
H	3.49 (88.6)	3.58 (90.9)	4.66 (118.4)	6.41 (162.8)
H1	1.00 (25.4)	1.25 (31.8)	1.50 (38.1)	2.00 (50.8)
H2*	.50 (12.7)	.50 (12.7)	.62 (15.7)	.75 (19.1)
H2**	.75 (19.1)	.75 (19.1)	1.00 (25.4)	1.25 (31.8)
H3	2.98 (75.7)	3.06 (77.7)	4.09 (103.9)	5.73 (145.5)
L	7.51 (190.8)	7.51 (190.8)	9.19 (233.4)	11.46 (291.1)
L1	3.00 (76.2)	3.00 (76.2)	3.87 (98.3)	4.75 (120.7)
L2	4.00 (101.6)	4.00 (101.6)	5.00 (127.0)	6.00 (152.4)
L3	3.00 (76.2)	3.00 (76.2)	3.87 (98.3)	4.75 (120.7)
L4	.50 (12.7)	.50 (12.7)	.56 (14.2)	.69 (17.5)
W	4.00 (101.6)	4.00 (101.6)	5.00 (127.0)	6.00 (152.4)
W1	3.00 (76.2)	3.00 (76.2)	3.87 (98.3)	4.75 (120.7)
Q (FT-LB)	65	65	295	515

*Side stop and free sliding units
**Fixed pin units



Your Rice Lake Weighing Systems distributor is:

RICE LAKE
WEIGHING SYSTEMS
To be the best by every measure®

230 W. Coleman St. • Rice Lake, WI 54868 • USA
TEL: 715-234-9171 • FAX: 715-234-6967 • www.ricelake.com

An ISO Registered Company © 2012 Rice Lake Weighing Systems PN 34026 5/12
Specifications subject to change without notice.