

# **IQ plus® 2100**

---

*Digital Bench Scale  
Version 1.02*

## **Installation Manual**





# Contents

<b>About This Manual</b> .....	<b>1</b>
<b>1.0 Introduction</b> .....	<b>1</b>
1.1 Operating Modes .....	1
1.2 Front Panel .....	2
1.3 LED Annunciators .....	2
1.4 Indicator Operations .....	2
<b>2.0 Installation</b> .....	<b>3</b>
2.1 Unpacking and Assembly .....	3
2.2 Factory Setup .....	3
<b>3.0 Configuration</b> .....	<b>4</b>
3.1 Configuration Methods .....	4
3.1.1 Revolution Configuration .....	4
3.1.2 EDP Command Configuration .....	4
3.1.3 Front Panel Configuration .....	5
3.2 Menu Structures and Parameter Descriptions .....	8
3.2.1 Configuration Menu .....	8
3.2.2 Format Menu .....	9
3.2.3 Calibration Menu .....	11
3.2.4 Serial Menu .....	12
3.2.5 Digital Input Menu .....	13
3.2.6 Default Menu .....	13
3.2.7 Version Menu .....	13
<b>4.0 Calibration</b> .....	<b>14</b>
4.1 Front Panel Calibration .....	14
4.2 EDP Command Calibration .....	15
4.3 Revolution™ Calibration .....	15
<b>5.0 EDP Commands</b> .....	<b>16</b>
5.1 The EDP Command Set .....	16
5.1.1 Key Press Commands .....	16
5.1.2 Reporting Commands .....	16
5.1.3 The RESETCONFIGURATION Command .....	16
5.1.4 Parameter Setting Commands .....	16
5.1.5 Normal Mode Commands .....	18
5.2 Saving and Transferring Data .....	18
5.2.1 Saving Indicator Data to a Personal Computer .....	18
5.2.2 Downloading Configuration Data from PC to Indicator .....	18
<b>6.0 Setup and Service Information</b> .....	<b>19</b>
6.1 Enclosure Disassembly .....	19
6.2 Cable Connections .....	19
6.2.1 Cable Grounding .....	19
6.2.2 Load Cells .....	20
6.2.3 Setting the Load Cell Compensation Jumper .....	20
6.2.4 Serial Communications .....	21
6.2.5 Digital Inputs .....	21



Technical training seminars are available through Rice Lake Weighing Systems. Course descriptions and dates can be viewed at [www.rlws.com](http://www.rlws.com) or obtained by calling 715-234-9171 and asking for the training department.

6.3	Enclosure Reassembly . . . . .	21
6.4	Board Removal . . . . .	21
6.5	IQ plus 210 Replacement Parts . . . . .	22
6.6	Bench Scale Maintenance . . . . .	26
6.6.1	Load Cell Replacement . . . . .	26
6.6.2	Bench Scale Adjustments . . . . .	27
6.6.3	Clamshell Installation . . . . .	27
6.7	RL2100 Replacement Parts . . . . .	28
<b>7.0</b>	<b>Appendix . . . . .</b>	<b>32</b>
7.1	Error Messages . . . . .	32
7.1.1	Displayed Error Messages . . . . .	32
7.1.2	Using the XE EDP Command . . . . .	32
7.2	Status Messages . . . . .	33
7.2.1	Using the P EDP Command . . . . .	33
7.2.2	Using the ZZ EDP Command . . . . .	33
7.3	Continuous Output (Stream) Format . . . . .	33
7.4	Specifications . . . . .	34
7.4.1	IQ plus 210 Indicator . . . . .	34
7.4.2	RL2100 Bench Scale . . . . .	34
	<b>IQ plus 2100 Limited Warranty . . . . .</b>	<b>35</b>

# About This Manual

This manual is intended for use by service technicians responsible for installing and servicing IQ plus<sup>®</sup> 2100 digital bench scales.

Configuration and calibration of the indicator can be accomplished using the indicator front panel keys, the EDP command set, or Version 2.3 or later of the Revolution<sup>™</sup> configuration utility. See Section 3.1 on page 10 for information about configuration methods



## Warning

*Some procedures described in this manual require work inside the indicator enclosure. These procedures are to be performed by qualified service personnel only.*



Authorized distributors and their employees can view or download this manual from the Rice Lake Weighing Systems distributor site at [www.rlws.com](http://www.rlws.com).

## 1.0 Introduction

---

The IQ plus 2100 digital bench scale consists of an IQ plus 210 digital weight indicator and an RL2100 bench scale. The indicator can be mounted to the bench scale using the 12-inch column or the attachment bracket, or can be separately mounted on the tilt stand.

The IQ plus 210 is a single-channel digital weight indicator housed in a NEMA 4X/IP66-rated stainless steel enclosure. The indicator front panel consists of a large (.8 in, 20 mm), six-digit, seven-segment LED display, seven LED annunciators, and two piezo switches used to zero the scale and select the displayed units. Features include:

- Drives up to four 350Ω load cells
- Supports 4- and 6-wire load cell connections
- Two configurable digital input
- Single serial port supports full duplex, RS-232 communications at up to 9600 bps
- Available in 115 VAC and 230 VAC versions

The RL2100 bench scale is available in the following configurations

- 5, 10, and 25 lb (2.5, 5, and 10 Kg) capacities with a 10" x 10" (25cm x 25cm) platform
- 50 and 100 lb (25 and 50 Kg) capacities with a 12" x 12" (30cm x 30cm) platform

The RL1042 anodized aluminum load cell is standard in the RL2100 bench scale; the RL1380 stainless steel load cell is available as an option. A stainless steel clamshell enclosure is also available for load cell protection.

### 1.1 Operating Modes

The IQ plus 210 has two modes of operation:

#### Normal (weighing) mode

Normal mode is the “production” mode of the indicator. The indicator displays the gross weight, and the LED annunciators described on page 2 indicate scale status and the type of weight value displayed. Once configuration is complete and legal seal is affixed to the back of the indicator, this is the only mode in which the IQ plus 210 can operate.

#### Setup mode

Most of the procedures described in this manual require the indicator to be in setup mode, including configuration and calibration

To enter setup mode, remove the large fillister head screw from the enclosure backplate. Insert a screwdriver or a similar tool into the access hole and press the setup switch once. The indicator display changes to show the word *CONFIG*.

## 1.2 Front Panel

Figure 1-1 shows the IQ plus 210 LED annunciators, buttons, and normal mode key functions.

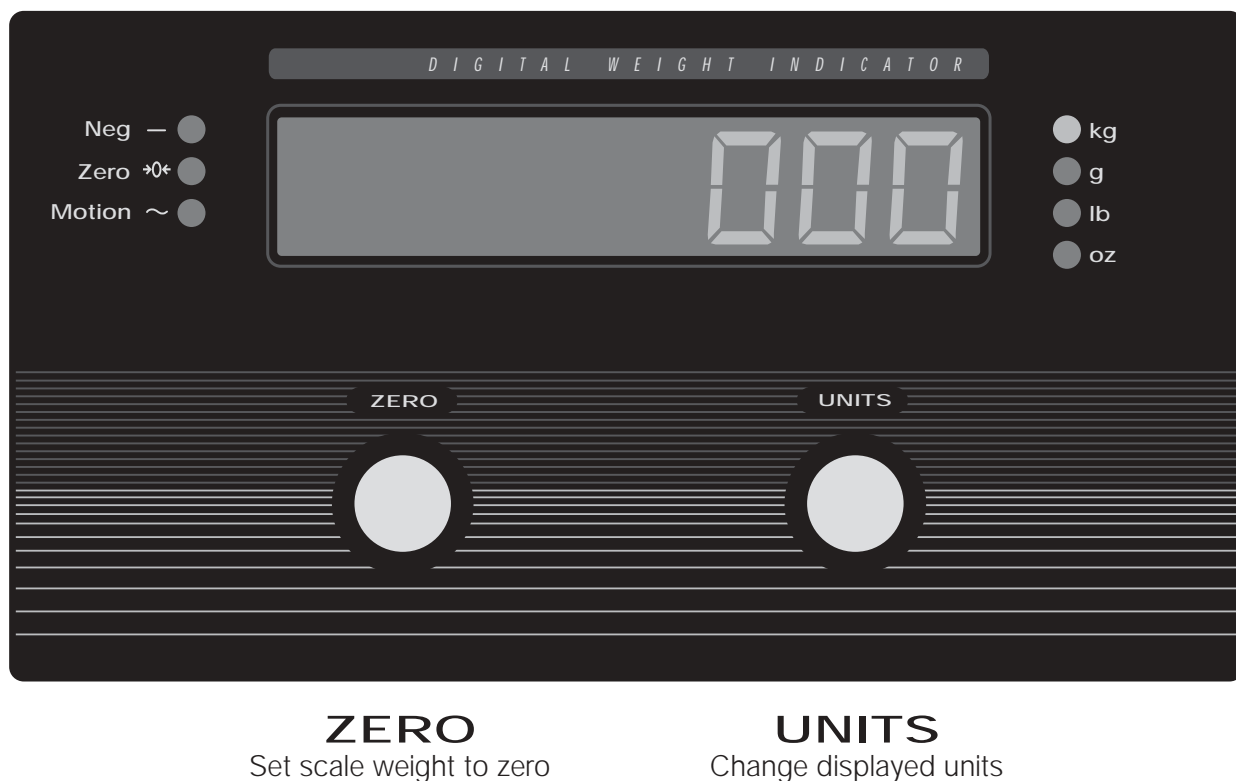

Figure 1-1. IQ plus 210 Front Panel, Showing LED Annunciators and Normal Mode Key Functions

## 1.3 LED Annunciators

The IQ plus 210 display uses a set of seven LED annunciators to provide additional information about the value being displayed:

- **Neg** annunciator lights to show that the displayed value is negative.
- **Zero**: Weight is within 0.25 graduations of zero. This annunciator lights when the scale is zeroed.
- **Motion**: Scale in motion outside the specific motion band. Zeroing and print operations can only be done when the motion LED is off.
- **lb**, **kg**, **oz**, and **g** annunciators indicate the units associated with the displayed value: **lb**=pounds, **kg**=kilograms, **oz**=ounces, **g**=grams. **lb** and **oz** annunciators are both lit when the displayed weight is in pounds and ounces.

## 1.4 Indicator Operations

Basic IQ plus 210 operations are summarized below.

### Zero Scale

1. Remove material from the scale and wait for the **Motion** LED to go out.
2. Press the **ZERO** button. The **Zero** annunciator lights to indicate the scale is zeroed.

### Change Display Units

Press the **UNITS** button to change the displayed units between primary and alternate units. The LED annunciators on the right side of the display show the current displayed units. If more than one alternate unit is configured, the display cycles through the alternate units before returning to primary units; if no alternate units are configured, the display does not change when the button is pressed.

## 2.0 Installation

The IQ plus 2100 digital bench scale is designed for easy setup and installation. All models are preconfigured and weight calibrated before shipment, with the load cell connected to the indicator. For simple, standalone scale applications, hardware installation consists of attaching the indicator, mounting assembly, and bench scale, then leveling the scale.

**NOTE:** *The IQ plus 2100 is weight calibrated before shipment from the factory, but recalibration at the installation site is strongly recommended. Calibration by a certified scale technician is required for Legal-for-Trade applications.*

### 2.1 Unpacking and Assembly

Immediately after unpacking, visually inspect the IQ plus 2100 to ensure all components are included and undamaged. The shipping carton should contain the indicator, the bench scale, the indicator mount (tilt stand, column, or attachment bracket), this manual, and a parts kit. If any parts were damaged in shipment, notify Rice Lake Weighing Systems and the shipper immediately.

The parts kit contains the items listed below:

- Capacity label (PN 42350)
- One grounding clamp (PN 53075), external tooth lock washer, (PN 15133), and kepinut (PN 14626) for digital input or serial cable shield grounding against the enclosure.
- Two wing knobs with nylon washers for attaching the indicator to the mounting assembly, four rubber tilt stand feet (for tilt stand option) or bench scale feet, jam nuts, lock washers, and cap screws (for column and attachment bracket options). See Section 6.7 on page 28 for replacement part numbers.

To install, attach the mounting assembly to scale base, then assemble the indicator to the mounting assembly. Place the bench scale in the desired location then lift off the scale platter and locate the bubble level. Adjust the corner feet until the scale is level and all feet are in contact with the support surface. Tighten the jam nuts against the scale to lock-in the level adjustment.

Plug power cord into power outlet to begin weighing.



#### Caution

*The supply cord serves as the power disconnect for the IQ plus 2100. The power outlet supplying the indicator must be installed near the unit and be easily accessible.*

### 2.2 Factory Setup

The IQ plus 2100 is preconfigured and weight calibrated at the factory before shipment. Table 2-1 lists the default graduations and count-by configuration for each scale capacity.

Scale Capacity	Count by	Configuration Parameters	
		DECPNT	DSPDIV
5 lb	0.001 lb	888.888	1D
10 lb	0.002 lb	888.888	2D
25 lb	0.005 lb	888.888	5D
50 lb	0.01 lb	8888.88	1D
100 lb	0.02 lb	8888.88	2D
2.5 Kg	0.0005 Kg	88.8888	5D
5 Kg	0.001 Kg	888.888	1D
10 Kg	0.002 Kg	888.888	2D
25 Kg	0.005 Kg	888.888	5D
50 Kg	0.01 Kg	8888.88	1D

NOTE: All capacities are preconfigured for 5000 graduations (GRADS parameter on CONFIG menu set to 5000).

*Table 2-1. Default Scale Configurations*

If scale configuration must be changed, see Section 3.0 on page 4 for detailed configuration information. See Section 4.0 on page 14 for calibration instructions.

## 3.0 Configuration

To configure the IQ plus 210 indicator, the indicator must be placed in setup mode. The setup switch is accessed by removing the large fillister head screw on the enclosure backplate. Insert a screwdriver into the access hole and press the switch to enter setup mode.

When the indicator is placed in setup mode, the word *CONFIG* is shown on the display. The CONFIG menu is the first of the main menus used to configure the indicator. Detailed descriptions of these menus are given in Section 3.2. When configuration is complete, press the setup switch again to exit setup mode, then replace the setup switch access screw.

### 3.1 Configuration Methods

The IQ plus 210 indicator can be configured by using the front panel buttons to navigate through a series of configuration menus or by sending commands or configuration data to the EDP port. Configuration using the menus is described in Section 3.1.3.

Configuration using the EDP port can be accomplished using either the EDP command set described in Section 5.0 or Version 2.3 or later of the Revolution™ configuration utility.

#### 3.1.1 Revolution Configuration

The Revolution configuration utility provides the preferred method for configuring the IQ plus 210 indicator. Revolution runs on a personal computer to set configuration parameters for the indicator. When Revolution configuration is complete, configuration data is downloaded to the indicator.



Figure 3-1. Sample Revolution Display

Revolution supports both uploading and downloading of indicator configuration data. This capability allows configuration data to be retrieved from one indicator, edited, then downloaded to another.

To use Revolution, do the following:

1. Install Revolution on an IBM-compatible personal computer running Windows® 3.11 or Windows 95. Minimum system requirements are 8MB of extended memory and at least 5MB of available hard disk space.
2. With both indicator and PC powered off, connect the PC serial port to the RS-232 pins on the indicator EDP port.
3. Power up the PC and the indicator. Use the setup switch to place the indicator in setup mode.
4. Start the Revolution program.

Figure 3-1 shows an example of one of the Revolution configuration displays.

Revolution provides online help for each of its configuration displays. Parameter descriptions provided in this manual for front panel configuration can also be used when configuring the indicator using Revolution; the interface is different, but the parameters set are the same.

#### 3.1.2 EDP Command Configuration

The EDP command set can be used to configure the IQ plus 210 indicator using a personal computer, terminal, or remote keyboard. Like Revolution, EDP command configuration sends commands to the indicator serial port; unlike Revolution, EDP commands can be sent using any external device capable of sending ASCII characters over a serial connection.

EDP commands duplicate the functions available using the indicator front panel and provide some functions not otherwise available. EDP commands can be used to simulate pressing front panel buttons, to configure the indicator, or to dump lists of parameter settings. See Section 5.0 on page 22 for more information about using the EDP command set.



### 3.1.3 Front Panel Configuration

The IQ plus 210 indicator can be configured using a series of menus accessed through the indicator front pane when the indicator is in setup mode. Table 3-1 summarizes the functions of each of the main menus.

Menu		Menu Function
CONFIG	Configuration	Configure grads, zero tracking, zero range, motion band, overload, and digital filtering parameters.
FORMAT	Format	Set format of primary units, select alternate display units.
CALIBR	Calibration	Calibrate indicator. See Section 4.0 on page 20 for calibration procedures.
SERIAL	Serial	Configure serial port.
DIG IN	Digital Input	Assign digital input functions.
DEFLT	Default	Restore default configuration.
VERS	Version	Display installed software version number.

*Table 3-1. IQ plus 210 Menu Summary*

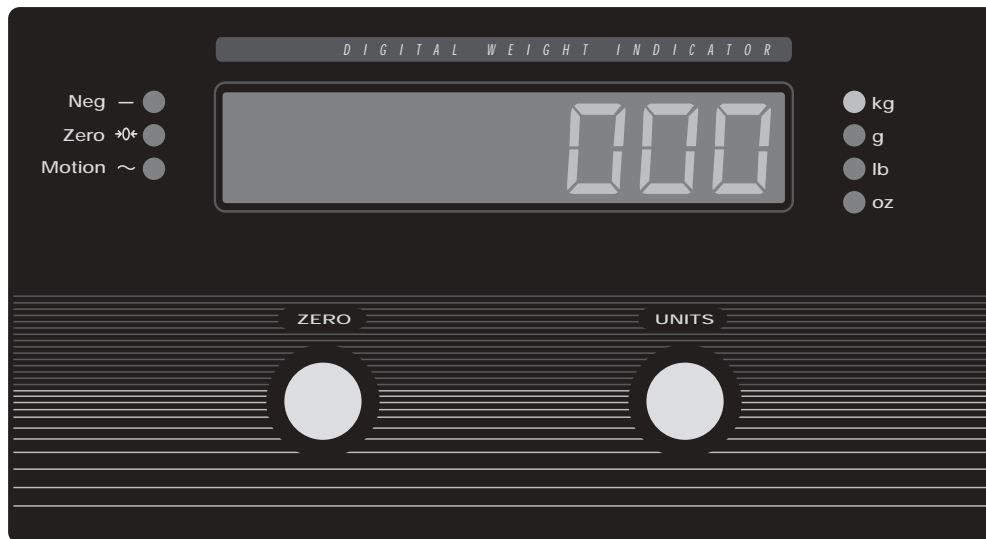

#### **ZERO/ENTER**

Move down in menu or enter parameter value and return to menu level above

#### **UNITS/RIGHT**

Move right in menu / next parameter value

*Figure 3-2. Front Panel Key Functions in Setup Mode*

## Front Panel Menu Navigation

The front panel buttons are used to navigate through the menus in setup mode (see Figure 3-2). The UNITS (RIGHT) button scrolls right (horizontally) on the same menu level; the ZERO (ENTER) button moves down (vertically) to different menu levels and serves as an Enter key for selecting parameter values within the menus.

Most of the configuration menus have three or four levels. Figure 3-3 shows the general structure of the IQ plus 210 configuration menus. Note the following:

- On the first (main) menu level, press RIGHT to scroll through the menus. Pressing RIGHT from the VERS menu wraps around to the CONFIG menu. Press ENTER from any of the main menus to move down to the first parameter for that menu.

- On the middle (parameter) menu levels, press RIGHT to scroll through the parameter prompts for the menu. When the last parameter is displayed, pressing RIGHT returns to the level above. Press ENTER from any parameter prompt to move down to the values prompts for that parameter.
- On the bottom (parameter value) menu level, press RIGHT to scroll through the values for the parameter. Pressing RIGHT from the last value wraps around to first value. Press ENTER to select the value and return to the parameter prompt.

Figure 3-4 on page 13 shows an example of the navigation used to select a parameter value under the SERIAL menu.

To edit numerical values, use the RIGHT button to select the digit; use the ENTER button to increment or decrement the value of the flashing digit (see Figure 3-5 on page 13). Once all digits have been edited, press ENTER to save the value and return to the parameter prompt.

## Menu Navigation General Structure

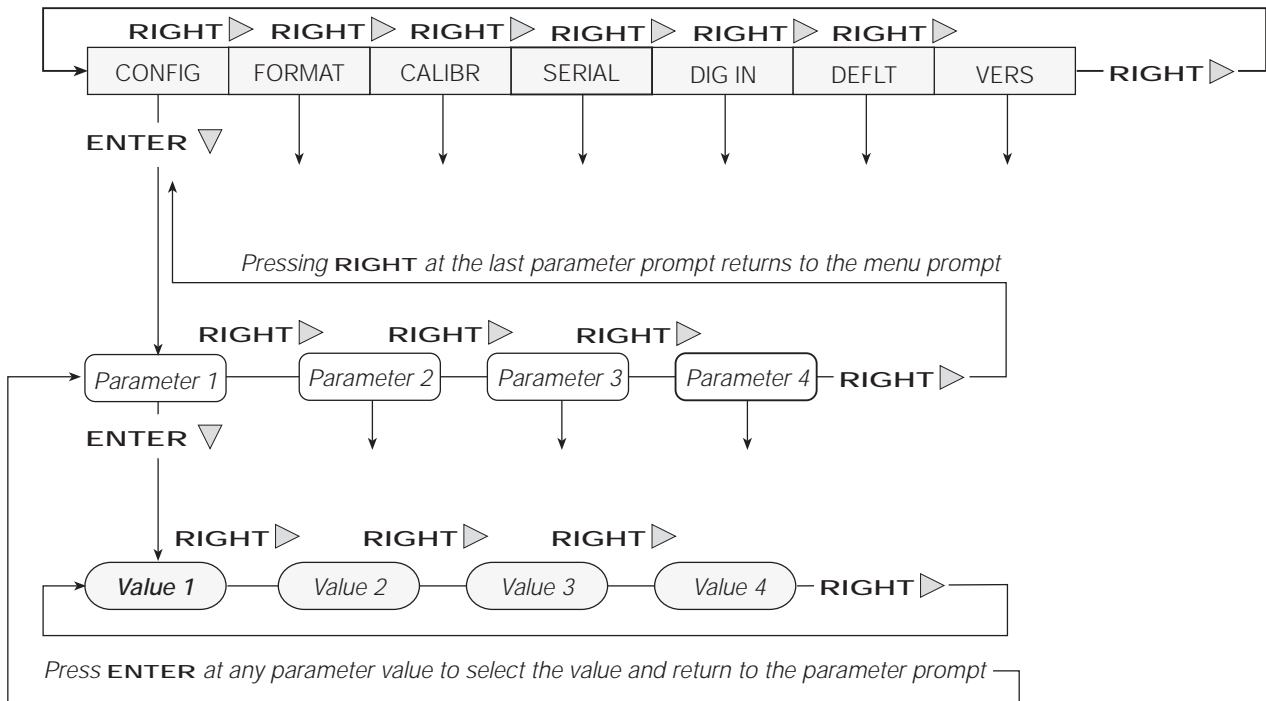
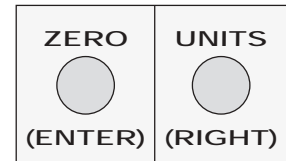

Figure 3-3. General Menu Structure

# Menu Navigation

## Serial Menu Example

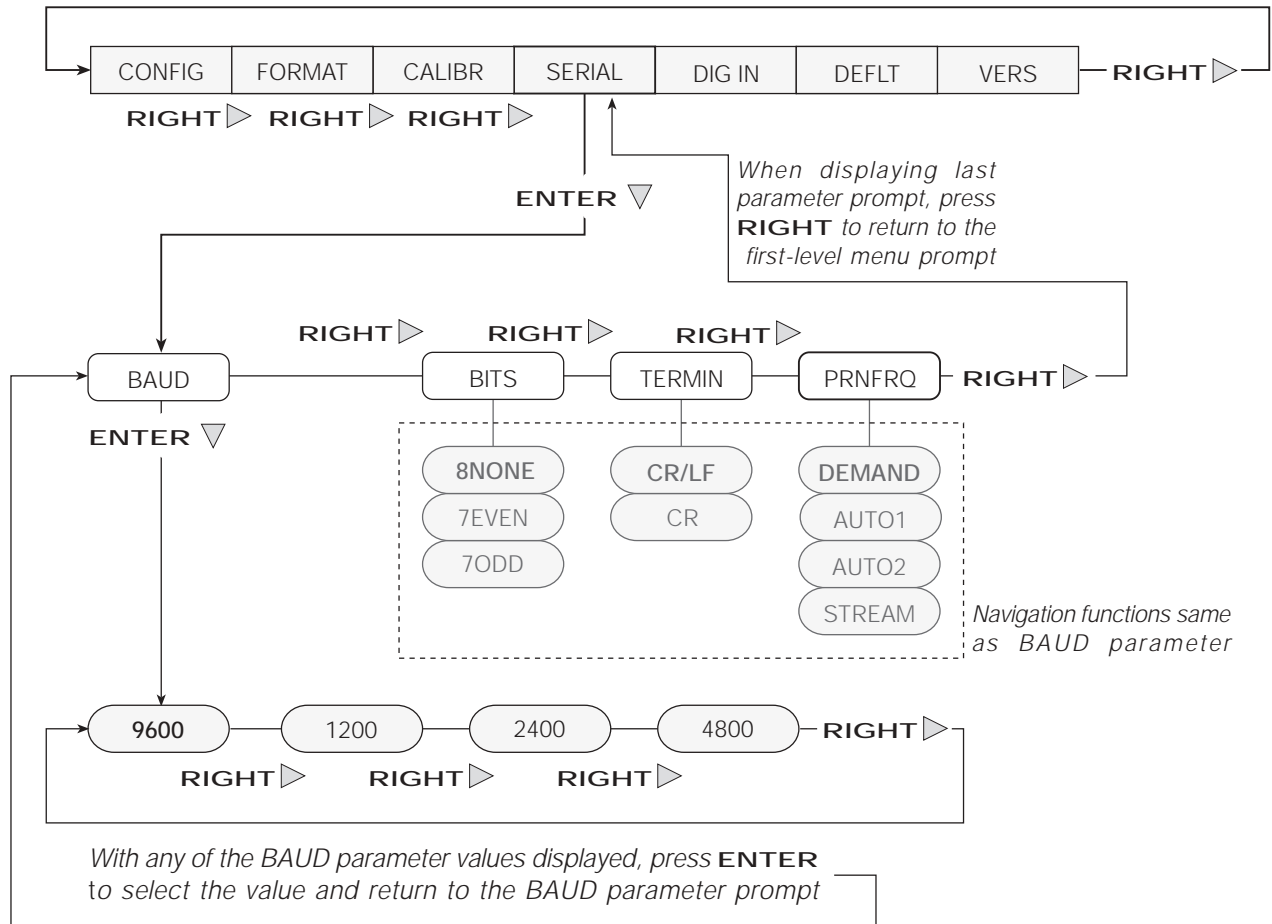
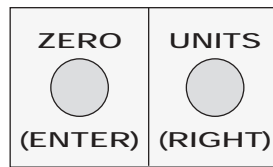

Figure 3-4. Setup Mode Menu Navigation



To edit numeric values, press the **UNITS (RIGHT)** button to select the leftmost digit. Each digit flashes when selected: Press **ZERO (ENTER)** to increment the value of the selected digit; press the **RIGHT** button to move right to the next digit.

Once the last digit has been edited, press **RIGHT** again and the digit stops flashing. Press **ENTER** to save the value entered and return to the menu level above, or press **RIGHT** to edit the value again, starting with the leftmost digit.

Figure 3-5. Editing Procedure for Numeric Values

## 3.2 Menu Structures and Parameter Descriptions

The following sections provide graphic representations of the IQ plus 210 menu structures. In the actual menu structure, the values under each parameter are arranged horizontally. To save page space, menu choices are shown in vertical columns. The factory default setting appears at the top of each column.

Most menu diagrams are accompanied by a table that describes all parameters and parameter values associated with that menu. Default parameter values are shown in bold type.

### 3.2.1 Configuration Menu

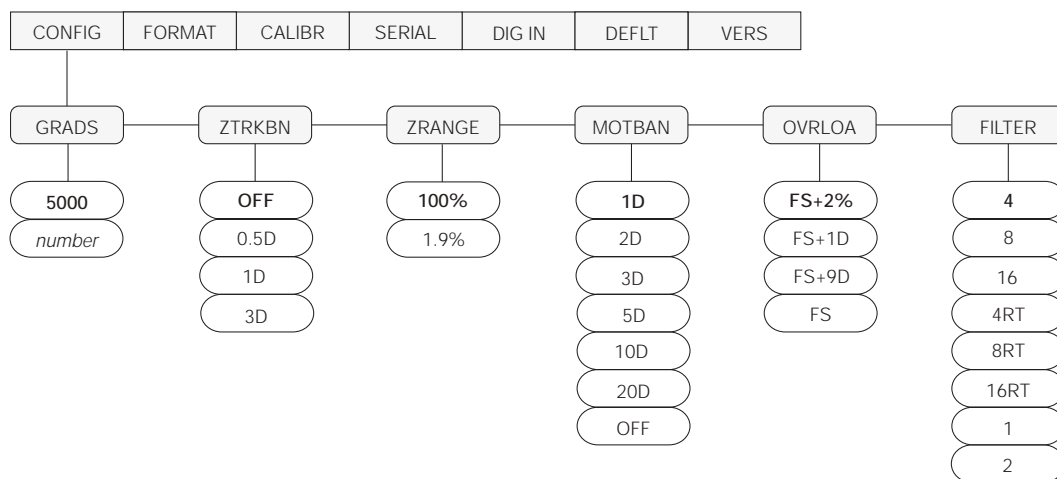

Figure 3-6. Configuration Menu

CONFIG Menu		
Parameter	Choices	Description
<i>Level 2 submenus</i>		
GRADS	<b>5000</b> <i>number</i>	Graduations. Specifies the number of full scale graduations. The value entered must be in the range 1–10 000 and should be consistent with legal requirements and environmental limits on system resolution.  To calculate GRADS, use the formula, $GRADS = Capacity / Display Divisions$ .  Display divisions for primary and secondary units are specified on the FORMAT menu.
ZTRKBN	<b>OFF</b> 0.5D 1D 3D	Zero track band. Automatically zeroes the scale when within the range specified, as long as the input is within the configured zero range (ZRANGE parameter). Selections are $\pm$ display divisions. Maximum legal value varies depending on local regulations.
ZRANGE	<b>100%</b> 1.9%	Zero range. Selects the range within which the scale can be zeroed. The 1.9% selection is $\pm$ 1.9% around the calibrated zero point, for a total range of 3.8%. Indicator must be at standstill to zero the scale. Use 1.9% for legal-for-trade applications.
MOTBAN	<b>1D</b> 2D 3D 5D 10D 20D OFF	Motion band. Sets the level, in display divisions, at which scale motion is detected. If motion is not detected for 1 second or more, the standstill symbol lights. Some operations, including print, tare, and zero, require the scale to be at standstill. Maximum legal value varies depending on local regulations.  If OFF is selected, ZTRKBN should also be set to OFF.

Table 3-2. Configuration Menu Parameters

CONFIG Menu		
Parameter	Choices	Description
OVRL0A	FS+2% FS+1D FS+9D FS	Overload. Determines the point at which the display blanks and an out-of-range error message is displayed. Maximum legal value varies depending on local regulations.
FILTER	4 8 16 4RT 8RT 16RT 1 2	Digital filtering. Selects the digital filtering rate used to reduce the effects of mechanical vibration from the immediate area of the scale.  Choices indicate the number of A/D conversions that are averaged to obtain the displayed reading. A higher number gives a more accurate display by minimizing the effect of a few noisy readings, but slows down the settling rate of the indicator. Values with the RT suffix provide a raised threshold for filtering larger noise spikes.

Table 3-2. Configuration Menu Parameters (Continued)

### 3.2.2 Format Menu

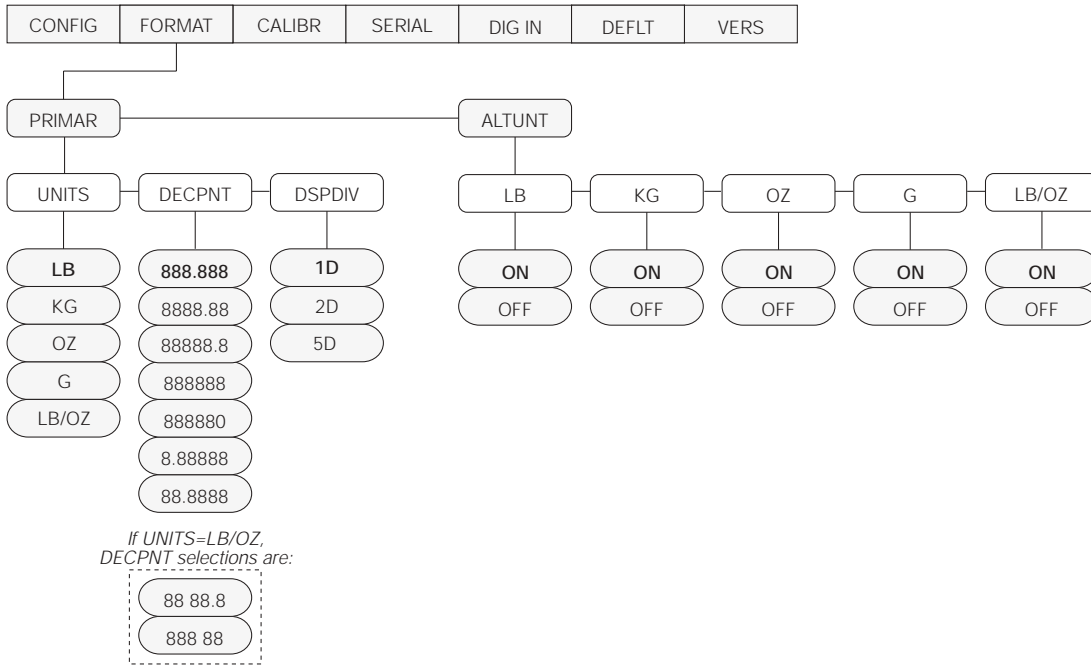

Figure 3-7. Format Menu

<b>FORMAT Menu</b>		
<b>Parameter</b>	<b>Choices</b>	<b>Description</b>
<i>Level 2 submenus</i>		
PRIMAR	UNITS DECPNT DSPDIV	Specifies the decimal position, display divisions, and units used for the primary units. See Level 3 submenu parameter descriptions.
ALTUNT	LB KG OZ G LB/OZ	Specifies which alternate units can be displayed by pressing the UNITS. See Level 3 submenu parameter descriptions.  <b>NOTE: The LB/OZ setting is not a Legal-for-Trade setting.</b>
<i>Level 3 submenus</i>		
<b>Primary Units (PRIMAR Parameter)</b>		
DECPNT	<b>888.888</b> 8888.88 88888.8 888888 888880 8.88888 88.8888 <i>or</i> 88 88.8 888 88	Decimal point location. Specifies the location of the decimal point or dummy zeroes in the primary unit display. Value should be consistent with local legal requirements.  If LB/OZ is selected as the primary unit, DECPNT selections are 88 88.8 and 888 88.
DSPDIV	<b>1D</b> 2D 5D	Display divisions. Selects the minimum division size for the primary units displayed weight.
UNITS	<b>LB</b> KG OZ G LB/OZ	Specifies primary units for displayed and printed weight. Values are: LB=pound; KG=kilogram; OZ=ounce; G=gram; LB/OZ=pounds and ounces.
<b>Alternate Units (ALTUNT Parameter)</b>		
LB KG OZ G LB/OZ	<b>ON</b> OFF	Alternate units. Determines which units are displayed when the UNITS button is pressed. The value for the primary unit (selected on the PRIMAR parameter) is always ON.  <b>NOTE: The LB/OZ setting is not a Legal-for-Trade setting.</b>

*Table 3-3. Format Menu Parameters*

### 3.2.3 Calibration Menu

See Section 4.0 on page 20 for calibration procedures.

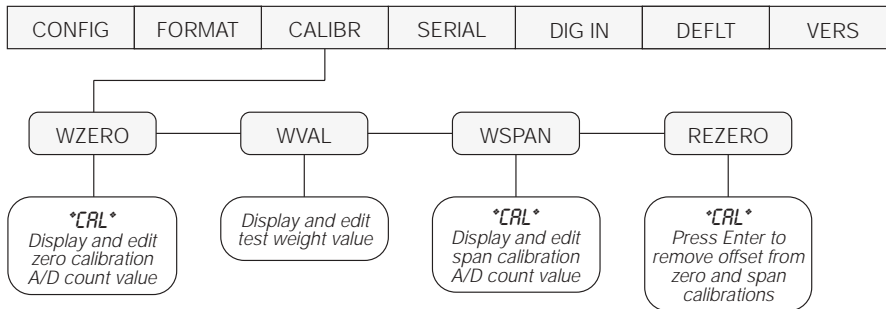

Figure 3-8. Calibration Menu

CALIBR Menu		
Parameter	Choices	Description
<i>Level 2 submenus</i>		
WZERO	—	Display and edit the zero calibration A/D count value.
WVVAL	—	Display and edit the test weight value.
WSPAN	—	Display and edit the span calibration A/D count value.
REZERO	—	Press ENTER to remove an offset value from the zero and span calibrations. Use this parameter only after WZERO and WSPAN have been set. See Section 4.1 on page 20 for more information about using this parameter.

Table 3-4. Calibration Menu Parameters

### 3.2.4 Serial Menu

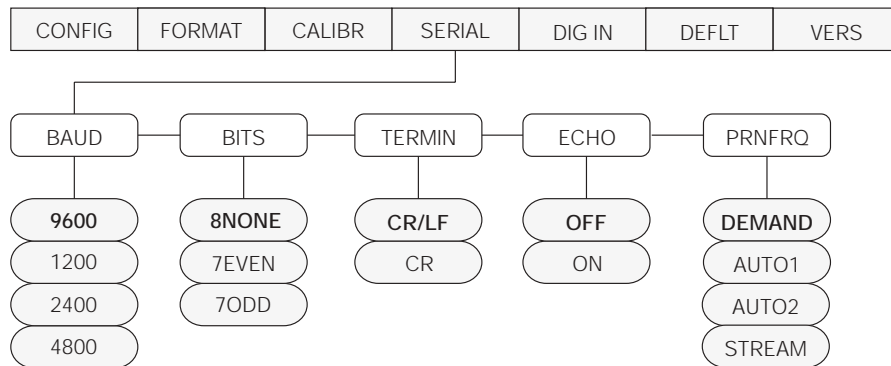

Figure 3-9. Serial Menu

SERIAL Menu		
Parameter	Choices	Description
BAUD	9600 1200 2400 4800	Baud rate. Selects the transmission speed for the serial port.
BITS	8NONE 7EVEN 7ODD	Selects number of data bits and parity of data transmitted from the serial port.
TERMIN	CR/LF CR	Termination character. Selects termination character for data sent from the serial port.
ECHO	OFF ON	This command enables or disables echoing of the serial commands sent to the indicator.
PRNFRO	DEMAND AUTO1 AUTO2 STREAM	<p>Print frequency. Specifies when the indicator sends data to the serial port:</p> <p>DEMAND: When a PRINT digital input is activated or the KPRINT EDP command received.</p> <p>AUTO1: Output enabled by scale in motion; transmitted when scale returns to standstill.</p> <p>AUTO2: Output enabled by scale at center of zero; transmitted when a positive scale weight is at standstill.</p> <p>STREAM: Continuous output. See Section 6.3 on page 26 for output format.</p> <p><i>Weight data is sent to the serial port in displayed units except when other units are specified using one of the XGx EDP commands (see Section 5.1.5 on page 24).</i></p> <p>If DEMAND, AUTO1, or AUTO2, is selected for this parameter, serial output is formatted as follows:</p> <p><b>wwwwwww uu GROSS</b></p> <p>where <b>wwwwwww</b> is a 7-digit weight field (leading zeroes suppressed, including decimal point and minus sign, if required), <b>uu</b> is the units designator (lb, kg, oz, or G).</p> <p>If pounds/ounces (LB/OZ) is specified as the primary units, the serial output is formatted as shown below:</p> <p><b>xxx lb yyyy oz GROSS</b></p> <p>where <b>xxx</b> is the three-digit pounds weight (including minus sign, if required) followed by <b>lb</b> and a space; and <b>yyyy</b> is the four-digit ounce weight (including decimal point) followed by <b>oz</b>.</p>

Table 3-5. Serial Menu Parameters



### 3.2.5 Digital Input Menu

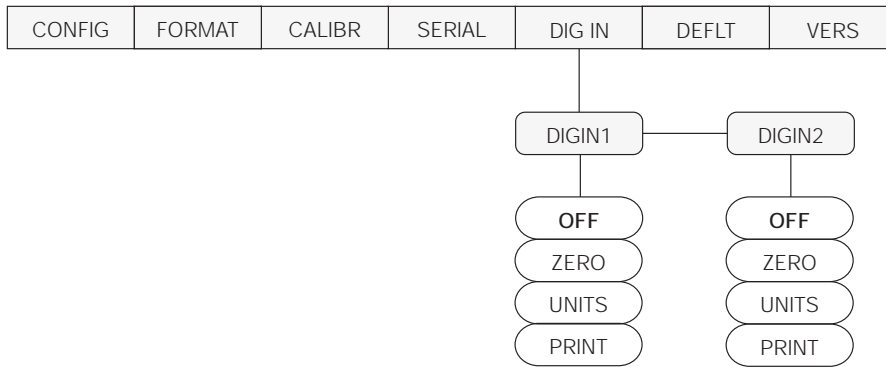

Figure 3-10. Digital Input Menu

DIG IN Menu		
Parameter	Choices	Description
<i>Level 2 submenus</i>		
DIGIN1 DIGIN2	OFF ZERO UNITS PRINT	Specifies the function activated by digital inputs 1 and 2.

Table 3-6. Digital Input Menu Parameters

### 3.2.6 Default Menu

The DEFLT menu is used to reset indicator configuration to the default values. There are no parameters associated with the DEFLT menu. From the DEFLT menu, press ENTER (ZERO) to move down to the RESET parameter. Press ENTER again to reset the indicator to the default configuration values or press RIGHT (UNITS) to cancel the indicator reset and return to the menu level above. **NOTE:** All load cell calibration settings are lost when the RESET function is performed.

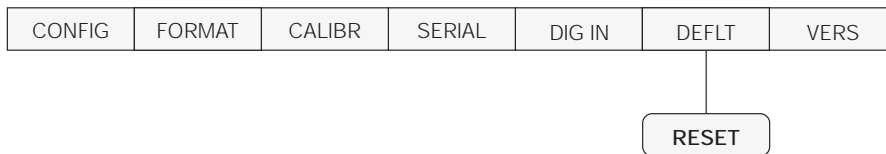

Figure 3-11. Default Menu

### 3.2.7 Version Menu

The VERS menu is used to check the software version installed in the indicator. There are no parameters associated with the VERS menu: when selected, the indicator displays the installed software version number.

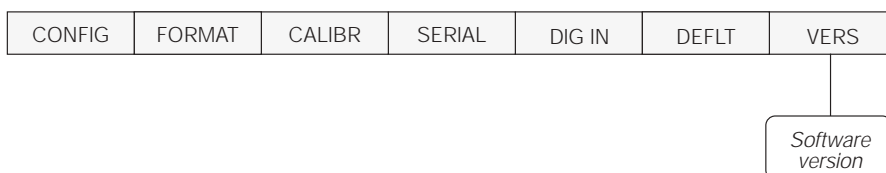

Figure 3-12. Version Menu

## 4.0 Calibration

The IQ plus 210 can be calibrated using the front panel, EDP commands, or the Revolution™ configuration utility. Each method consists of the following steps:

- Zero calibration
- Entering the test weight value
- Span calibration
- Optional rezero calibration for test weights using hooks or chains.

The following sections describe the calibration procedure for each of the calibration methods.

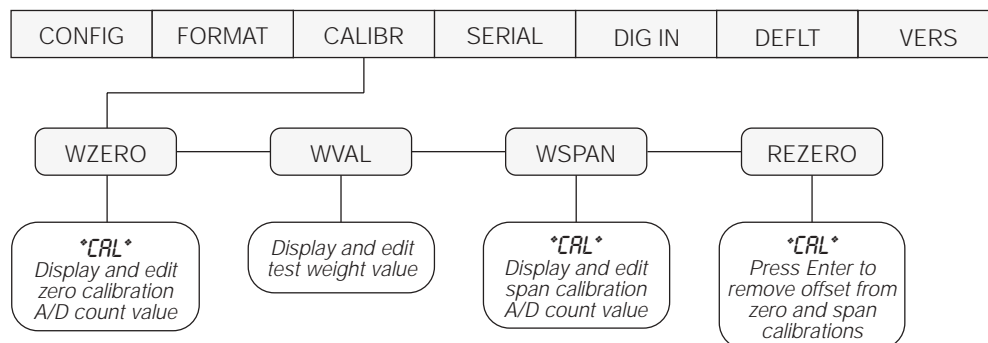

Figure 4-1. Calibration (CALIBR) Menu

### 4.1 Front Panel Calibration

To calibrate the indicator using the front panel, do the following:

1. Place the indicator in setup mode (display reads *CONFIG*) and remove all weight from the scale platform. If your test weights require hooks or chains, place the hooks or chains on the scale for zero calibration.
2. Press the **RIGHT (UNITS)** button until the display reads *CALIBR* (see Figure 4-1). Press **ENTER (ZERO)** to go to zero calibration (*WZERO*).
3. With *WZERO* displayed, press **ENTER** to calibrate zero. The indicator displays *°CAL°* while calibration is in progress. When complete, the A/D count for the zero calibration is displayed. Press **ENTER** again to save the zero calibration value and return to the *WZERO* prompt or use the procedure shown in Figure 4-2 to edit the value. When done, press **RIGHT** to go to the *WVAL* prompt.
4. With *WVAL* displayed, press **ENTER** to show the test weight value. If the value is equal to the test weight you are using, press **ENTER** again to save the value and return to the *WVAL* prompt; if the value is incorrect, use the procedure shown in Figure 4-2 to edit the value. When done, press **RIGHT** to go to the *WSPAN* prompt.
5. With *WSPAN* displayed, place test weights on the scale then press **ENTER** to calibrate span. The indicator displays *°CAL°* while calibration is in progress. When complete, the A/D count for the span calibration is displayed. Press **ENTER** again to save the span calibration value and return to the *WSPAN* prompt or use the procedure shown in Figure 4-2 to edit the value. When done, press **RIGHT** to go to the *REZERO* prompt.

**NOTE:** When calibrating the indicator with *LB/OZ* as the primary unit, enter the *WVAL* value in ounces. For example, to calibrate a 5 lb scale using *LB/OZ*, enter 80 (5 lb x 16 oz/lb) as the *WVAL* value.



To edit numeric values, press the **UNITS (RIGHT)** button to select the leftmost digit. Each digit flashes when selected: Press **ZERO (ENTER)** to increment the value of the selected digit; press the **RIGHT** button to move right to the next digit.

Once the last digit has been edited, press **RIGHT** again and the digit stops flashing. Press **ENTER** to save the value entered and return to the menu level above, or press **RIGHT** to edit the value again, starting with the leftmost digit.

Figure 4-2. Editing Procedure for Numeric Values

6. The rezero function is used to remove a calibration offset when hooks or chains are used to hang the test weights.
  - If no other apparatus was used to hang the test weights during calibration, remove the test weights and press RIGHT to return to the CALIBR menu.
  - If hooks or chains were used during calibration, remove these and the test weights from the scale. With all weight removed, press ENTER to rezero the scale. This function adjusts the zero and span calibration values. The indicator displays °CAL° while the zero and span calibrations are adjusted. When complete, the adjusted A/D count for the zero calibration is displayed. Press ENTER again to save the rezero value and return to the REZERO prompt or use the procedure shown in Figure 4-2 to edit the value. When done, press RIGHT to return to the CALIBR menu.
7. Press the setup switch to exit setup mode.

## 4.2 EDP Command Calibration

To calibrate the indicator using EDP commands, the indicator EDP port must be connected to a terminal or personal computer. (See Section 2.3.3 on page 5 for EDP port pin assignments; see Section 5.0 on page 22 for more information about using EDP commands.) Once the indicator is connected to the sending device, do the following:

1. Place the indicator in setup mode (display reads CONFIG) and remove all weight from the scale platform. If your test weights require hooks or chains, place the hooks or chains on the scale for zero calibration.
2. Send the WZERO EDP command to calibrate zero. The indicator displays °CAL° while calibration is in progress.
3. Send the WVAL command to enter the test weight value in the following format:  
WVAL=nnnnnn<CR>
4. Place test weights on scale equal to the specified WVAL.
5. Send the WSPAN EDP command to calibrate span. The indicator displays °CAL° while calibration is in progress.
6. To remove an offset value, clear all weight from the scale, including hooks or chains used to hang test weights, then send the REZERO EDP command. The indicator displays °CAL° while the zero and span calibrations are adjusted.
7. Send the KEXIT EDP command to exit setup mode.

## 4.3 Revolution™ Calibration

To calibrate the indicator using Revolution, the indicator must be in setup mode with the EDP port connected to a PC running the Revolution configuration utility. Use the following procedure to calibrate the indicator:

1. Select *Calibrate Indicator* from the Revolution main menu.
2. On the Weight Calibration display, select the indicator model (IQ+210) and communications port then click *OK*.
3. Revolution uploads calibration data from the indicator then presents the information in a display like that shown in Figure 4-3.
4. Enter the *Value of Test Weight* to be used for span calibration then click *OK*.
5. The Zero Calibration dialog box prompts you to remove all weight from the scale. Clear the scale and click *OK* to begin zero calibration. **NOTE:** *If your test weights require hooks or chains, place the hooks or chains on the scale for zero calibration.*
6. When zero calibration is complete, the Span Calibration dialog box prompts you to place test weights on the scale for span calibration. Place test weights on the scale then click *OK*.
7. The Rezero dialog box prompts you to remove all weight, from the scale (including hooks or chains). Remove the weights then click *OK*.
8. When calibration is complete, the *New Settings* fields of the Weight Calibration display are filled in. Click *Exit* to save the new values and return to the Revolution main menu; to restore the previous calibration values, click *Restore Settings*.



Figure 4-3. Revolution Calibration Display

## 5.0 EDP Commands

The IQ plus 210 indicator can be controlled by a personal computer or remote keyboard connected to the indicator serial port. Control is provided by a set of EDP commands that can simulate front panel key press functions, display and change setup parameters, and perform reporting functions. The EDP port provides the capability to print configuration data or to save that data to an attached personal computer. This section describes the EDP command set and procedures for saving and transferring data using the serial port.

### 5.1 The EDP Command Set

The EDP command set can be divided into five groups: key press commands, reporting commands, the RESETCONFIGURATION special function command, parameter setting commands, and transmit weight data commands.

When the indicator processes an EDP command, it responds with the message *OK*. The *OK* response verifies that the command was received and has been executed. If the command is unrecognized or cannot be executed, the indicator responds with *??*.

The following sections list the commands and command syntax used for each of these groups.

#### 5.1.1 Key Press Commands

Key press EDP commands (see Table 5-1) simulate pressing the buttons on the front panel of the indicator.

Command	Function
KZERO	Press the ZERO button
KUNITS	Press the UNITS button
KPRIM	Display primary units
KPRINT	Send demand data to serial port
KRIGHTARROW	In setup mode, move right in the menu (press the UNITS button)
KENTER	In setup mode, press the ENTER (ZERO) button
KEXIT	In setup mode only, exit setup mode

Table 5-1. EDP Key Press Commands

#### 5.1.2 Reporting Commands

Reporting commands (see Table 5-2) send specific information to the EDP port. These commands can be used in both setup mode and normal mode.

Command	Function
DUMPALL	List all parameter values
VERSION	Write IQ plus 210 software version
P	Write current displayed weight. See Section 6.2 on page 26 for more information.
ZZ	Write current weight and annunciator status. See Section 6.2 on page 26 for more information.
RS	Reset the indicator
S	Write one frame of stream format

Table 5-2. EDP Reporting Commands

#### 5.1.3 The RESETCONFIGURATION Command

The RESETCONFIGURATION command can be used to restore all configuration parameters to their default values.

This command is equivalent to using the RESET function on the DEFLT menu.

**NOTE:** All load cell calibration settings are lost when the RESETCONFIGURATION command is run.

#### 5.1.4 Parameter Setting Commands

Parameter setting commands allow you to display or change the current value for a particular configuration parameter (Tables 5-3 through 5-8).

Current configuration parameter settings can be displayed in either setup mode or normal mode using the following syntax:

*command*<ENTER>

Most parameter values only can be changed in setup mode. Use the following command syntax when changing parameter values:

*command*=*value*<ENTER>

where *value* is a number or a parameter value. Use no spaces before or after the equal (=) sign. If you type an incorrect command or value, the display reads *??*. Changes to the parameters are saved as they are entered but typically do not take effect until you exit setup mode.

For example, to set the motion band parameter to 5, type the following:

*MOTBAND=5D*<ENTER>

Command	Description	Values
GRADS	Graduations	1–10 000
ZTRKBD	Zero track band	OFF, 0.5D, 1D, 3D
ZRANGE	Zero range	1.9%, 100%
MOTBAND	Motion band	1D, 2D, 3D, 5D, 10D, 20D, OFF
OVRLD	Overload	FS+2%, FS+1D, FS+9D, FS
FILTER	Digital filtering	1, 2, 4, 8, 16, 4RT, 8RT, 16RT

*Table 5-3. CONFIG EDP Commands*

Command	Description	Values
PRI.DECPNT	Primary units decimal position	8.88888, 88.8888, 888.888, 8888.88, 88888.8, 888888, 888880 (88 88.8 or 888 88 in LB/OZ display mode)
PRI.DSPDIV	Primary units display divisions	1D, 2D, 5D
PRI.UNITS	Primary units	LB, KG, OZ, G, LB/OZ
ALT.LB ALT.KG ALT.OZ ALT.G ALT.LBOZ	Enable alternate units	ON, OFF

*Table 5-4. FORMAT EDP Commands*

Command	Description	Values
WZERO	Zero calibration	—
WVAL	Test weight value	<i>test_weight_value</i>
WSPAN	Span calibration	—
REZERO	Rezero	—
LC.CD	Set deadload count	<i>value</i>
LC.CW	Set span count	<i>value</i>

*Table 5-5. CALIBR EDP Commands*

Command	Description	Values
EDP.BAUD	Serial port baud rate	1200, 2400, 4800, 9600
EDP.BITS	Serial port data bits/parity	8NONE, 7EVEN, 7ODD
EDP.TERMIN	Serial port termination character	CR/LF, CR
EDP.ECHO	Serial port echo command	OFF, ON
PRNFREQ	Print frequency	DEMAND, AUTO1, AUTO2, STREAM

*Table 5-6. SERIAL EDP Commands*

Command	Description	Values
DIGIN1 DIGIN2	Digital input function	OFF, ZERO, UNITS, PRINT

*Table 5-7. DIG IN EDP Commands*

### 5.1.5 Normal Mode Commands

The serial transmit weight data commands (see Table 5-8) transmit data to the serial port on demand. The transmit weight data commands are valid only in normal operating mode.

Command	Description	Response Format
SX	Start serial streaming	OK or ??
EX	Stop serial streaming	OK or ??
RS	Reset system	—
XG	Transmit gross weight in displayed units	<i>nnnnnn UU</i>
XGL	Transmit gross weight in pounds	where <i>nnnnnn</i> is the weight value, <i>UU</i> is the units.
XGK	Transmit gross weight in kilograms	
XGO	Transmit gross weight in ounces	
XGG	Transmit gross weight in grams	
XGC	Transmit gross weight in pounds and ounces	
XE	Query system error conditions	<i>nnnnn nnnnn</i> See Section 6.1.2 on page 25 for detailed information about the XE command response format.

Table 5-8. Normal Mode EDP Commands

## 5.2 Saving and Transferring Data

Connecting a personal computer to the IQ plus 210 EDP port allows you to save indicator configuration data to the PC or to download configuration data from the PC to an indicator. The following sections describe the procedures for these save and transfer operations.

### 5.2.1 Saving Indicator Data to a Personal Computer

Configuration data can be saved to a personal computer connected to the EDP port. The PC must be running a communications program such as PROCOMMPLUS®. See Section 2.3.3 on page 5 for information about serial communications wiring and EDP port pin assignments.

When configuring the indicator, ensure that the values set for the BAUD and BITS parameters on the SERIAL menu match the baud rate, bits, and parity settings configured for the serial port on the PC.

To save all configuration data, send the DUM ALL EDP command to the indicator. The IQ plus 210 responds by sending all configuration parameters to the PC as ASCII-formatted text.

### 5.2.2 Downloading Configuration Data from PC to Indicator

Configuration data saved on a PC or floppy disk can be downloaded from the PC to an indicator. This procedure is useful when a number of indicators with similar configurations are set up or when an indicator is replaced.

To download configuration data, connect the PC to the EDP port as described in Section 5.2.1. Place the indicator in setup mode and use the PC communications software to send the saved configuration data to the indicator. When transfer is complete, calibrate the indicator as described in Section 4.0 on page 20.

#### NOTES:

- Calibration settings are included in the configuration data downloaded to the indicator. If the receiving indicator is a direct replacement for another IQ plus 210 and the attached scale is not changed, recalibration is not required.
- When downloading configurations that include changed serial communications settings, edit the data file to place the serial communication changes at the end of the file. Communication between the PC and indicator will be lost once the indicator receives settings for baud rate (BAUD parameter) or data bits and parity (BITS parameter) that do not match those configured for the PC.



## 2.0 Setup and Service Information

This section describes setup and service procedures for the IQ plus 2100 digital bench scale, including installation and maintenance information, replacement parts lists, and assembly drawings. See Sections 2.1 through 2.5 for IQ plus 210 indicator information; see Sections 6.6 and 6.7 for bench scale information.

### 2.1 Enclosure Disassembly

The indicator enclosure must be opened to connect cables after replacing the load cell, or when connecting serial communications cables or digital inputs to the scale.

**Warning** *The IQ plus 210 has no on/off switch. Before opening the unit, ensure the power cord is disconnected from the power outlet.*

#### Caution

- Use a wrist strap to ground yourself and protect components from electrostatic discharge (ESD) when working inside the indicator enclosure.
- This unit uses double pole/neutral fusing which could create an electric shock hazard. Procedures requiring work inside the indicator must be performed by qualified service personnel only.
- The supply cord serves as the power disconnect for the IQ plus 2100. The power outlet supplying the indicator must be installed near the unit and be easily accessible

Ensure power to the indicator is disconnected, then remove the screws that hold the backplate to the enclosure body, then lift the backplate away from the enclosure and set it aside.

### 2.2 Cable Connections

The IQ plus 210 provides three cord grips for cabling into the indicator: two for the power cord and load cell cabling, the third for communications and digital input cables. The free cord grip comes with a plug installed to prevent moisture from entering the enclosure. If your application requires serial communication or digital input cabling, remove the plug and install cables as described in Sections 2.2.4 and 2.2.5 on page 5.

#### 2.2.1 Cable Grounding

Except for the power cord, all cables routed through the cord grips should be grounded against the indicator enclosure. Do the following to ground shielded cables:

- Use the lockwashers, clamps, and keep nuts provided in the parts kit to install grounding clamps on the studs adjacent to the cord grips. Install grounding clamps only for cord grips that will be used; do not tighten nuts.

- Route cables through cord grips and grounding clamps to determine cable lengths required to reach cable connectors. Mark cables to remove insulation and shield as described below:
- For cables with foil shielding, strip insulation and foil from the cable half an inch (15 mm) past the grounding clamp (see Figure 2-1). Fold the foil shield back on the cable where the cable passes through the clamp. Ensure silver (conductive) side of foil is turned outward for contact with the grounding clamp.
- For cables with braided shielding, strip cable insulation and braided shield from a point just past the grounding clamp. Strip another half inch (15 mm) of insulation *only* to expose the braid where the cable passes through the clamp (see Figure 2-1).
- **IMPORTANT!** For load cell cables, strip the yellow shield wire 3/4" past the grounding clamp. Fold wire back and secure between the cable and clamp. Shield wire function is provided by contact between the cable shield and the grounding clamp.
- Route stripped cables through cord grips and clamps. Ensure shields contact grounding clamps as shown in Figure 2-1. Tighten grounding clamp nuts.
- Finish installation using cable mounts and ties to secure cables inside of indicator enclosure.

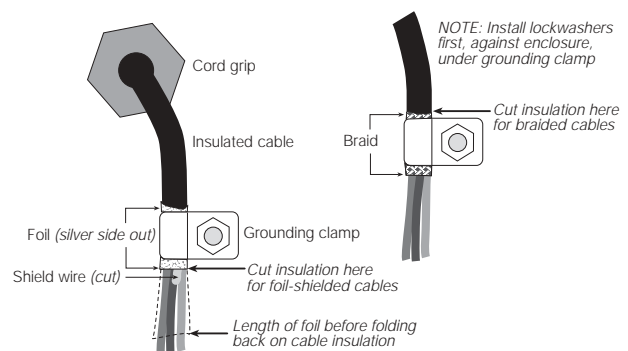

Figure 2-1. Grounding Clamp Attachment for Foil-Shielded and Braided Cabling

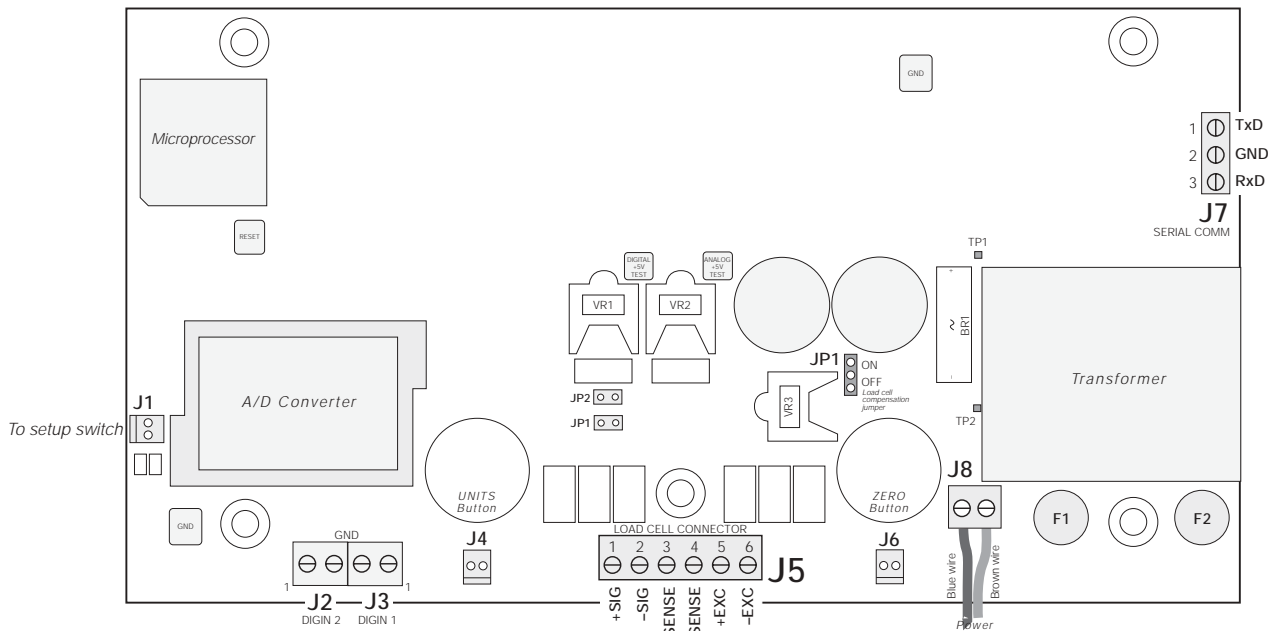

Figure 2-2. IQ plus 210 CPU and Power Supply Board

### 2.2.2 Load Cells

Wire the load cell cable to connector J5 as shown in Table 2-1. If using 6-wire load cell cable (with sense wires), remove jumpers JP1 and JP2 (see Figure 2-2). For 4-wire installation, leave jumpers JP1 and JP2 on.

**NOTE:** All models come with ten feet of color-coded load cell cable. **Do not cut this cable!** The load cell is temperature-compensated for an exact cable length of ten feet. Cutting the load cell cable voids the load cell warranty.

When connections are complete, use two cable ties to secure the load cell cable to the inside of the enclosure.

J5 Pin	Function	Load Cell Wire Color	
		RL1040 RL1042	RL1380
1	+SIG	Red	White
2	-SIG	White	Red
3	+SENSE	Blue	—
4	-SENSE	Brown	—
5	+EXC	Green	Green
6	-EXC	Black	Black

**NOTES:**

1. Use grounding procedure described in Section 2.2.1 on page 3 to attach shield wire to backplate.
2. For 6-wire connections, remove jumpers JP1 and JP2.

Table 2-1. J5 Pin Assignments

### 2.2.3 Setting the Load Cell Compensation Jumper

The load cell compensation jumper (above the ZERO button location on the CPU board; see Figure 2-2) must be set for the type of load cell connected to the indicator:

- For load cells with balanced bridges, set the jumper in the OFF position. Balanced load cells include the RL1040, RL1250, RL1260, RL1380, and RL1385.
- For load cells with unbalanced bridges, follow the procedure below to determine the correct jumper position. Examples of unbalanced cells include the RL1042 and RL1010.

To determine the correct jumper position for unbalanced cells, do the following:

1. Disconnect load cell from indicator.
2. Use an ohmmeter to measure +EXC to +SIG and +EXC to -SIG. Measured values between the excitation line and each of the signal lines should be within 2–3Ω.
3. Next, measure -EXC to +SIG and -EXC to -SIG. Measured values between the excitation line and each of the signal lines should be within 2–3Ω.
4. If the +EXC measurements (step 2) are ≥ 5% larger than the -EXC measurements (step 3), set the compensation jumper in the ON position. If the +EXC measurements are < 5% greater (or are less) than the -EXC measurements, set the jumper in the OFF position.



### 2.2.4 Serial Communications

To attach serial communications cables, connect communications cables to connector J7 as shown in Table 2-2. Use cable ties to secure serial cable to the inside of the enclosure.

Use the SERIAL menu to configure serial communications. See Section 3.2.4 on page 18 for configuration information

J7 Pin	Label	Function
1	TxD	RS-232 TxD
2	GND	RS-232 Ground
3	RxD	RS-232 RxD

Table 2-2. J7 Pin Assignments

### 2.2.5 Digital Inputs

Digital inputs (connectors J2 and J3) can be used to perform remote ZERO and UNITS key presses or to send serial data to a printer (remote PRINT key function). The inputs are active (on) with low voltage (0 VDC) and can be driven by TTL or 5V logic without additional hardware. Use the DIG IN menu to configure the digital inputs. See Section 3.2.5 on page 19 for information about configuring the digital inputs

## 2.3 Enclosure Reassembly

Once cabling is complete, position the backplate over the enclosure and reinstall the backplate screws. Use the torque pattern shown in Figure 2-3 to prevent distorting the backplate gasket. Torque screws to 15 in-lb (1.7 N-m).

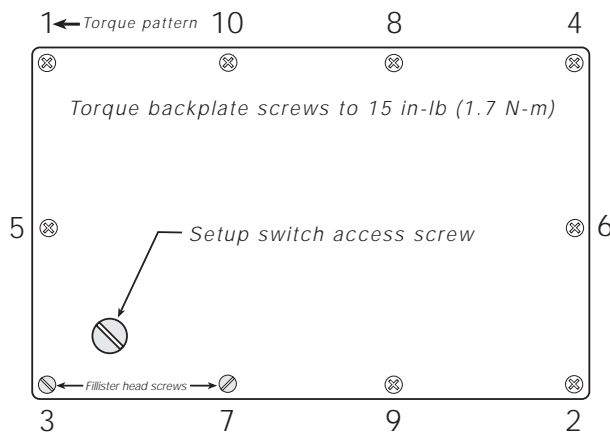

Figure 2-3. IQ plus 210 Enclosure Backplate

## 2.4 Board Removal

If you must remove the IQ plus 210 CPU board, use the following procedure:

1. Disconnect power to the indicator . Remove backplate as described in Section 2.1 on page 3.
2. Remove connections to J5 (load cell cable), J7 (serial communications), J2 and J3 (digital inputs), J4 and J6 (piezo button inputs), and J1 (setup switch). Remove blue and brown power input wires at J8. See Figure 2-2 on page 4 for connector locations.
3. Remove the fi e nuts from the CPU board, then lift the board out of the enclosure.

To replace the CPU board, reverse the above procedure. Be sure to reinstall cable ties to secure all cables inside the indicator enclosure.

## 2.5 IQ plus 210 Replacement Parts

Table 2-3 lists replacement parts for the IQ plus 210, including all parts referenced in Figures 2-4 through 2-8.

Ref Number	PN	Description (Quantity)	Figure
1	14626	Keyp nuts, 8-32NC hex (3)	Figure 2-4 on page 7, Figure 2-7 on page 8
2	53651	Display and CPU board assembly, 115 VAC (1)	Figure 2-5 on page 8
	53650	Display and CPU board assembly, 230 VAC (1)	
3	15365	Board mounting spacers (5)	
4	52483	Enclosure backplate (1)	Figure 2-4 on page 7
5	15626	Cable grips, PG9 (2)	Figure 2-8 on page 9
6	30375	Nylon seal rings for cable grips (3)	
7	15627	Locknuts, PCN9 (3)	
8	19538	Cable grip plugs (2)	
9	45042	Sealing washers (10)	Figure 2-4 on page 7
10	44676	Sealing washer for setup switch access screw (1)	
11	42640	Setup switch access screw, 1/4 x 28NF x 1/4 (1)	
12	41965	Power cord assembly, 115VAC (1)	Figure 2-8 on page 9
	45254	Power cord assembly, 230VAC (1)	
13	41964	Line filter assembly (1)	Figure 2-6 on page 8
14	14621	Keyp nuts, 6-32NC hex (5)	Figure 2-5 on page 8
20	15134	Lock washers, internal tooth, No. 8 , Type A (4)	Figure 2-4 on page 7, Figure 2-7 on page 8
22	52853	Overlay membrane panel (1)	Figure 2-8 on page 9
23	52482	Enclosure (1)	
24	14862	Screws, 8-32NC x 3/8 (8)	
26	45043	Ground wire, 4-in., No. 8 (1)	Figure 2-4 on page 7
27	39037	Backplate gasket (1)	
28	49910	Setup switch assembly (1)	
29	16892	Ground/Earth Label (1)	Figure 2-6 on page 8
30	15650	Cable tie mounts (1)	
31	45302	Line filter standoffs (2)	
33	15131	Lock washers, external tooth, No. 6, Type A (10)	
34	61113	Piezo switches (2)	Figure 2-8 on page 9
35	30623	Fillister head screws, 8-32NC x 7/16 (2)	Figure 2-4 on page 7
—	53848	200 mA TR5 subminiature fuses (2), 115 VAC	F1 and F2 in Figure 2-2 on page 4 (See Caution below)
	53881	100 mA TR5 subminiature fuses (2), 230 VAC	
 <b>Caution</b> For protection against risk of fire, replace fuses only with same type and rating fuse. See Section 6.4 on page 27 for complete fuse specifications.			

*Table 2-3. Replacement Parts*

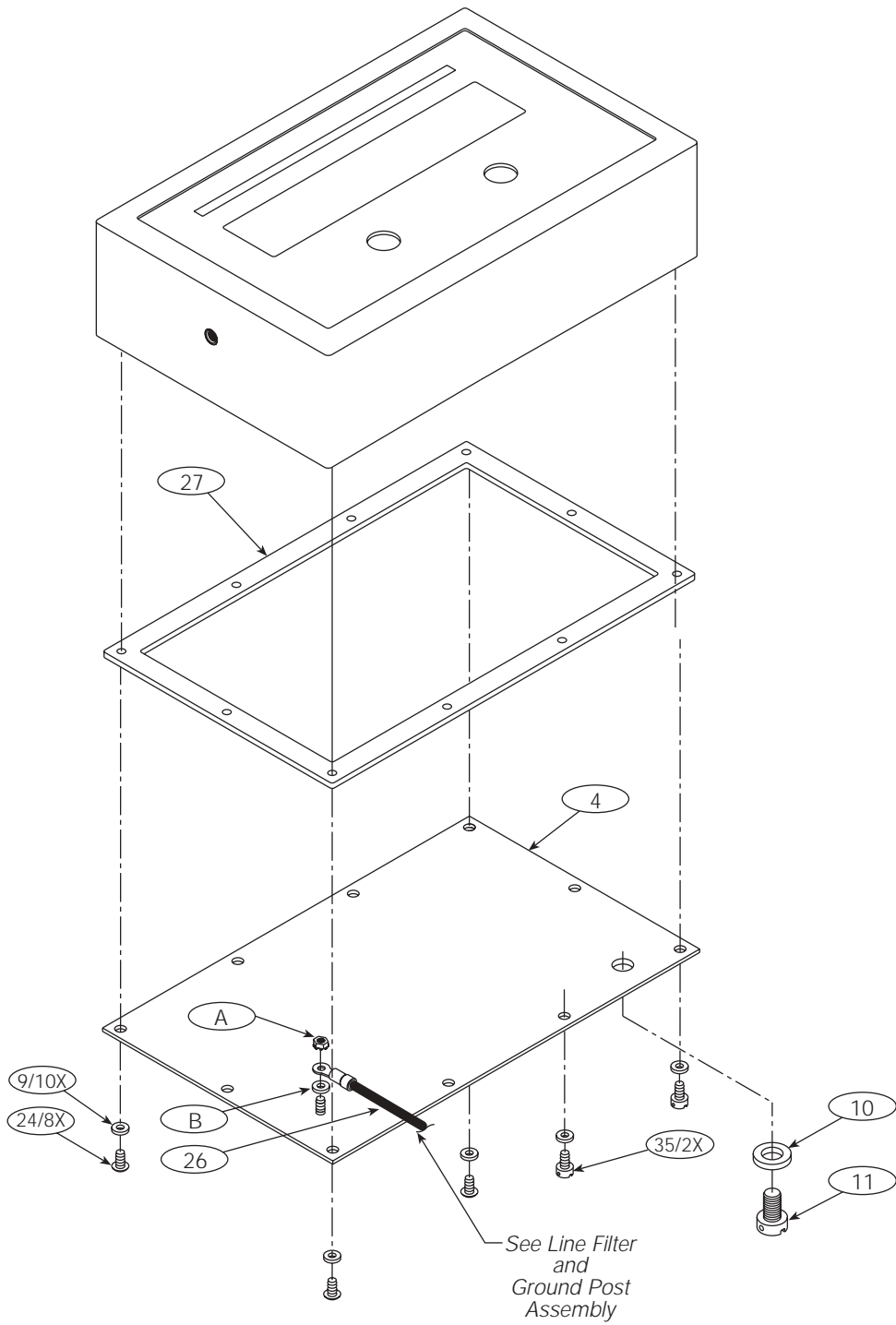

Figure 2-4. IQ plus 210 Backplate Assembly

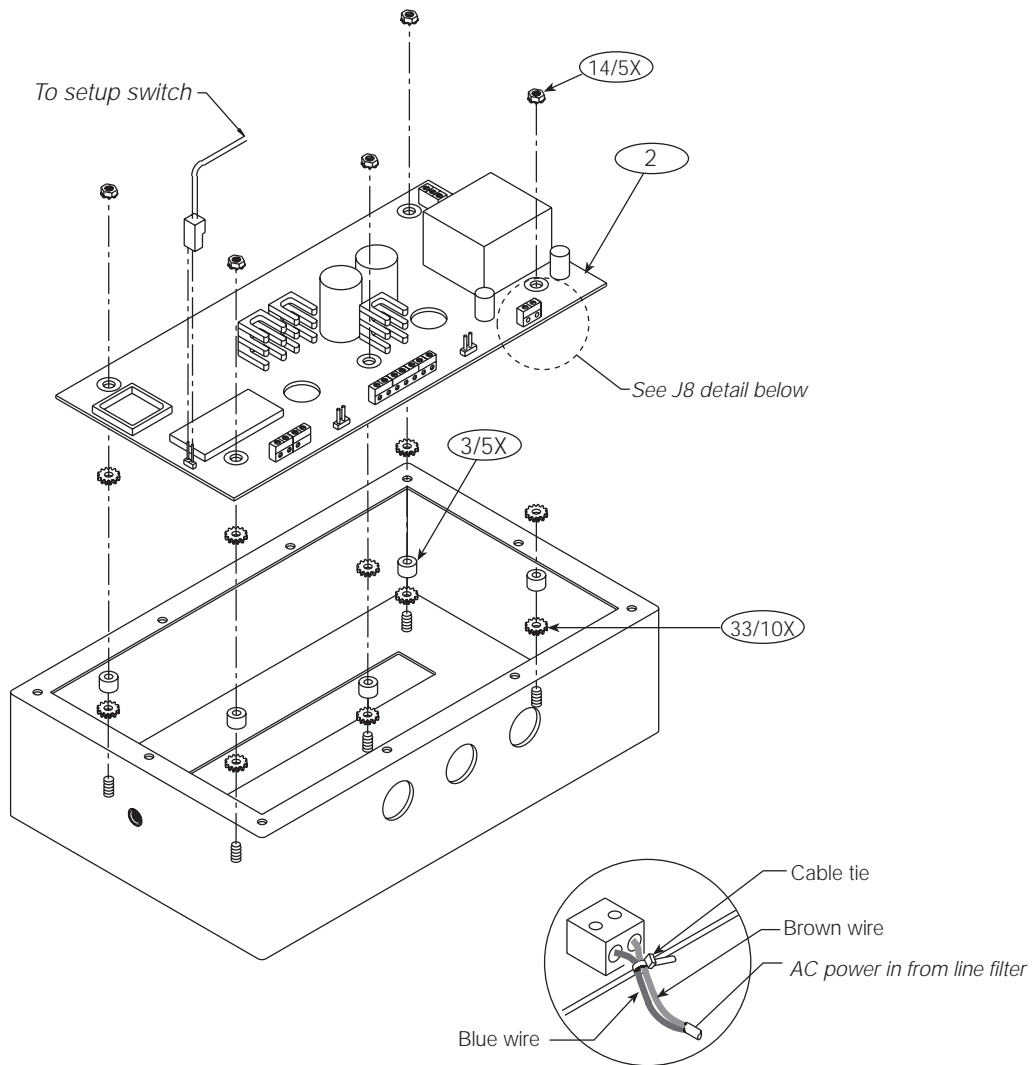

Figure 2-5. IQ plus 210 Enclosure and CPU Board

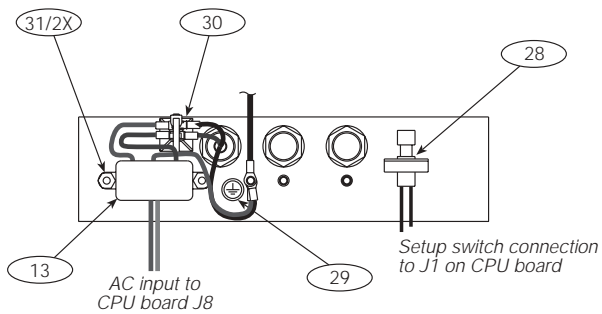

Figure 2-6. Line Filter Assembly

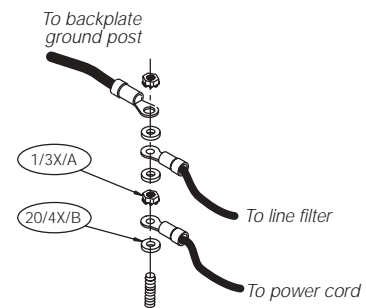

Figure 2-7. Ground Post Assembly

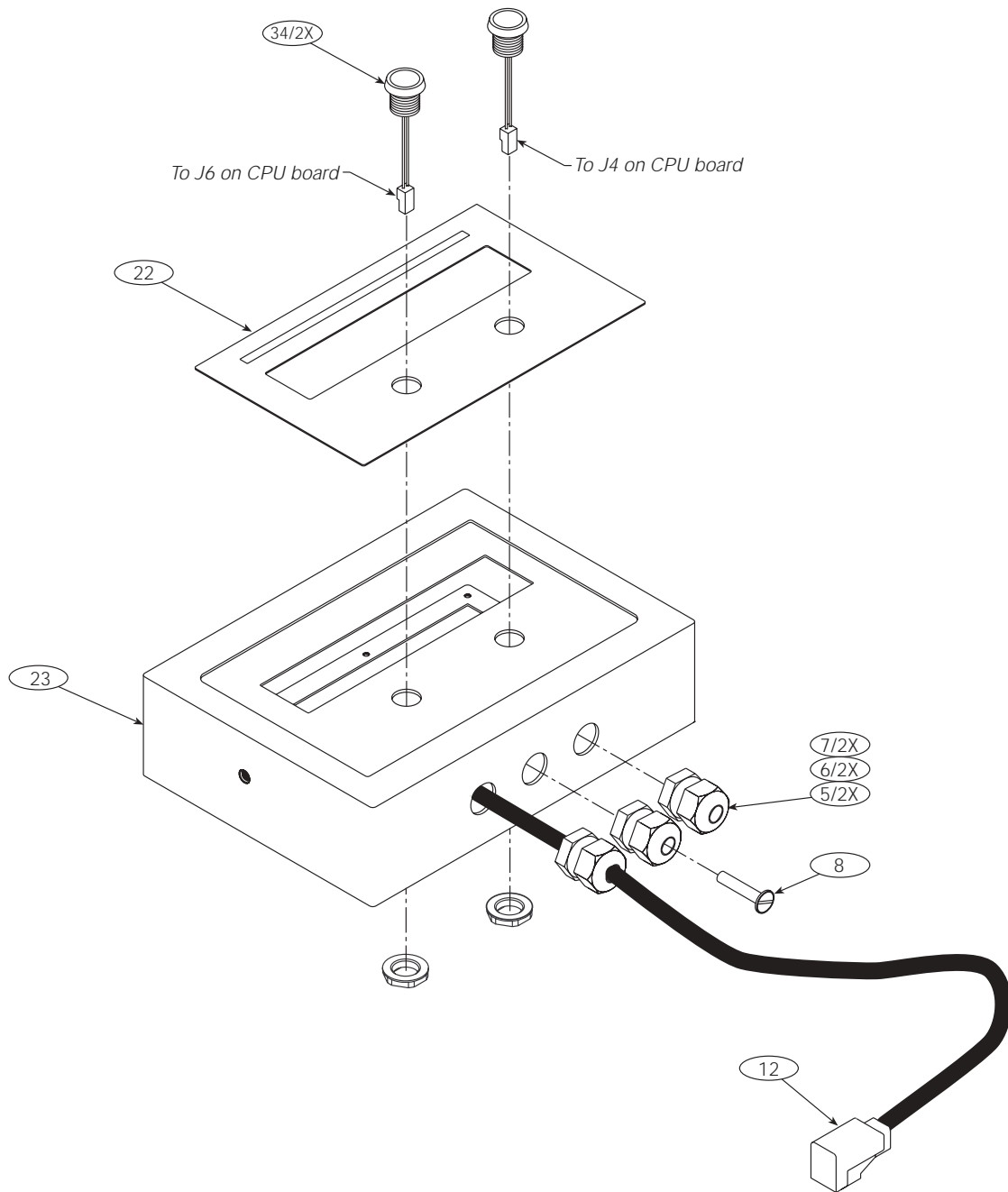

Figure 2-8. IQ plus 210 Enclosure and Overlay

## 6.6 Bench Scale Maintenance

This section provides instructions for replacing load cell, adjusting lift-up and overload protection screws, and installing the optional clamshell enclosure. See Section 6.7 on page 28 for additional drawings and information about RL2100 replacement parts.

### 6.6.1 Load Cell Replacement

Use the following procedure to replace the load cell in RL2100 bench scales:

1. Disconnect power to the indicator.

**Warning** Before opening the indicator enclosure, ensure power to the indicator is disconnected.

2. Disconnect the load cell cable at the indicator.
3. Lift off scale platter. Remove lift-up protection screws from spider plate and base assembly.
4. Use 7/16" wrench to remove upper load cell screws and lock washers. Remove spider plate and upper load cell shim from load cell.
5. Turn scale over and unscrew overload protection set screw one full turn.
6. Use 7/16" wrench to remove lower load cell

7. Thread replacement load cell cable through rubber grommet.
8. Position load cell on lower shim. Install lower load cell lockwashers and screws. Torque to 80 in-lb (9.0 N-m).
9. Set scale on its feet. Position upper shim on load cell, then install spider plate and lift-up protection screws.
10. Install upper load cell lockwashers and screws. Torque to 80 in-lb (9.0 N-m).
11. Replace scale platter. Ensure that scale is level.
12. Connect load cell cable to indicator (see Table 6-1 on page 20).
13. Readjust lift-up protection screws and overload protection set screw as described under Section 6.6.2 on page 27.
14. Power-up indicator and recalibrate scale.

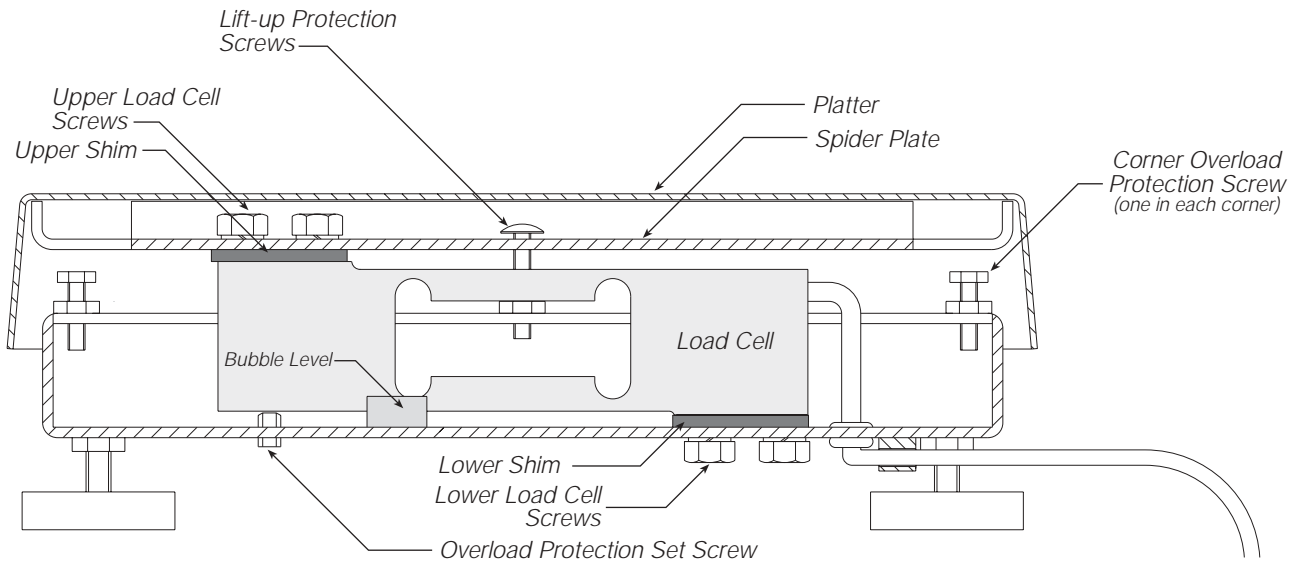

Figure 6-9. RL2100 Components (Side View)

### 6.6.2 Bench Scale Adjustments

The RL2100 bench scale uses a number of screws to provide overload and underload protection for the load cell. These protection screws are all set at the factory before shipment; use the following information to verify and reset protection screws.

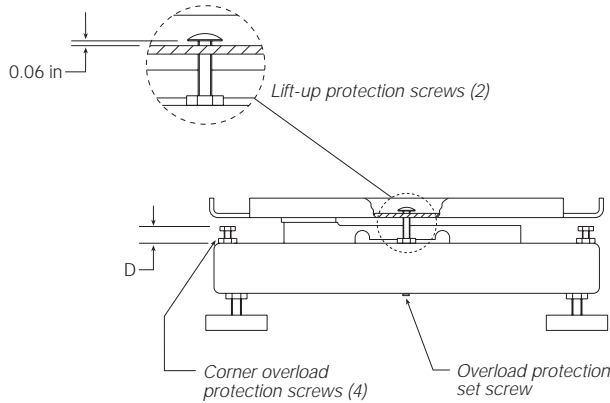

Figure 6-10. RL2100 Protection Screw Adjustments

- **Lift-up Protection Screws**  
Set lift-up protection screw height to 0.06 in (1.52 mm).

- **Overload Protection Set Screw**  
Elevate the scale base to allow sufficient clearance to adjust the set screw, then center a load equal to 125% of scale capacity on the platter. Use a hex wrench to advance the set screw until it touches the load cell, then back off 1/6 of a turn. Verify calibration, then add a drop of non-permanent thread adhesive (such as LOCTITE®) to prevent the set screw from vibrating loose.
- **Corner Overload Protection Screws**  
The correct height of the corner overload protection screws depends on the scale capacity. Adjust the four screws to the heights shown in Table 6-4.

Model (Capacity)	Corner Overload Protection Screw Height (D)
5 lb (2.5 Kg)	0.56 in (142 mm)
10 lb (5 Kg)	0.50 in (127 mm)
25 lb (10 Kg)	
50 lb (25 Kg)	
100 lb (50 Kg)	

Table 6-4. Corner Protection Screw Height

### 6.6.3 Clamshell Installation

Protective stainless steel clamshells are available as an option for all RL2100 bench scales. Clamshells are pre-drilled for load cell screws, overload screw, and cables. Existing load cell shims are reinstalled inside the clamshells.

To install the clamshell, do the following:

1. Remove platter, spider plate, and load cell using the procedure described in Section 6.6.1 on page 26.
2. Install lower clamshell in base. Route load cell cable through lower clamshell and grommet, then reinstall lower shim and load cell so that no part of the load cell touches the clamshell enclosure. Replace lower load cell screws and lockwashers. Torque to 80 in-lb (9.0 N-m).
3. Install upper clamshell, ensuring clearance on all sides to prevent binding against the lower clamshell. Reinstall upper shim, spider plate, lockwashers, and upper load cell screws. Torque screws to 80 in-lb (9.0 N-m).
4. Replace scale platter. Ensure that scale is level.
5. Readjust lift-up protection screws and overload protection set screw on bottom of scale base as described under Section 6.6.2.
6. Connect load cell cable to indicator. Power-up indicator and recalibrate scale.

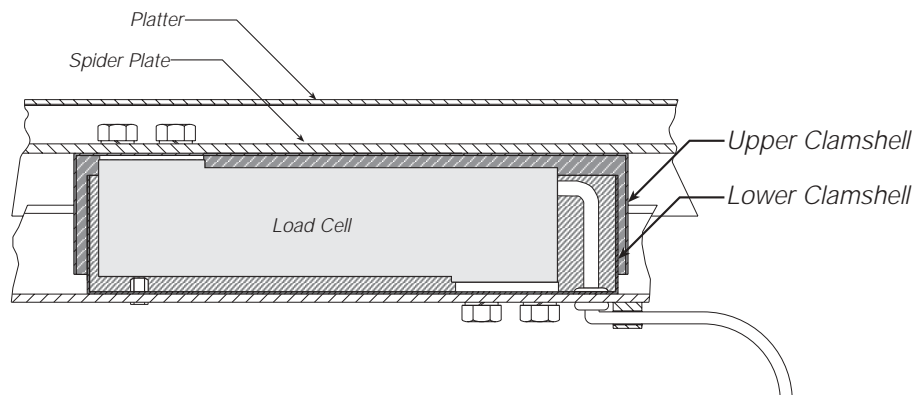

Figure 6-11. Clamshell Installation

## 6.7 RL2100 Replacement Parts

The following table list replacement parts for the RL2100, including all parts referenced in Figures 6-12 through 6-15 on the following pages. See Table 6-9 for load cell replacement part numbers.

### Bench Scale Parts

Ref Number	PN	Description (Quantity)
1	51332	Platter, 10x10 (1)
	51333	Platter, 12x12 (1)
2	50880	Spider plate, 10x10 (1)
	51335	Spider plate, 12x12 (1)
3	50881	Base, 10x10, 5-Lb model (1)
	63233	Base, 10x10, 10- & 25-Lb models (1)
	63430	Base, 12x12 (1)
4	—	Load cell (see Table 6-9)
5	35082	Upper load cell shim, 10x10 models (1)
	52383	Upper load cell shim, 12x12 models (1)
6	15410	Bubble level (1)
7	21948	Cap screws, 1/4-20NC x 5/8 (2)
8	15148	Lock washers, 1/4 (4)
9	52341	Overload protection cap screws, 10/32NF x 3/4 (4)
10	39025	Nuts, 10-32NF hex, 18-8 (6)
11	15408	Rubber grommet, 3/16 ID (1)
12	15409	Cable clamp, No. 8 (1)
13	14862	Machine screw, 8-32NC x 3/8 (1)
14	14645	Jam nuts, 1/4-20NC hex SST (4)
15	35128	Scale feet, 1/4-20NC x 1 3/16 (4)
16	43203	Overload protection set screw, 8-32NC x 1/2 (1)
17	63170	Lift-up protection machine screws, 10-32NF x 1 1/4 (2)
18	14963	Cap screws, 1/4-20NC x 3/4 (2)
19	52383	Lower load cell shim (1)

Table 6-5. RL2100 Replacement Parts (see Figure 6-12 on page 29)

### Tilt Stand Assembly Parts

Ref Number	PN	Description (Quantity)
1	29635	Tilt stand (1)
2	42149	Tilt stand feet (4)
3	15144	Nylon washers, 1/4x1x1/16 (2)
4	30342	Wing knobs (2)

Table 6-6. Tilt Stand Assembly (see Figure 6-13 on page 30)

### Attachment Bracket Assembly Parts

Ref Number	PN	Description (Quantity)
1	50879	Attachment bracket
2	15408	Rubber grommet, 3/16 ID (1)
3	14956	Cap screws, 1/4-20NC x 1/2 (2)
4	15148	Lock washers, 1/4 (2)
5	14645	Jam nuts, 1/4-20NC hex SST (2)
6	35128	Bench scale feet, 1/4-20NC (2)
7	30342	Wing knobs (2)
8	15144	Nylon washers, 1/4x1x1/16 (2)

Table 6-7. Attachment Bracket Assembly (see Figure 6-14 on page 30)

### Column Assembly Parts

Ref Number	PN	Description (Quantity)
1	52539	12-inch column
2	15148	Lock washers, 1/4 (2)
3	14956	Cap screws, 1/4-20NC x 1/2 (2)
4	14645	Jam nuts, 1/4-20NC hex SST (2)
5	35128	Bench scale feet, 1/4-20NC (2)
6	30342	Wing knobs (2)
7	15144	Nylon washers, 1/4x1x1/16 (2)

Table 6-8. Column Assembly (see Figure 6-15 on page 31)

### Replacement Load Cells

RL2100 Model	Load Cell Part Number	
	RL1042	RL1380
10x10, 5 lb	40957	30783
10x10, 10 lb	40959	30781
10x10, 25 lb	40961	30780
12x12, 50 lb	40962	30779
12x12, 100 lb	40964	30779

Table 6-9. Replacement Load Cells



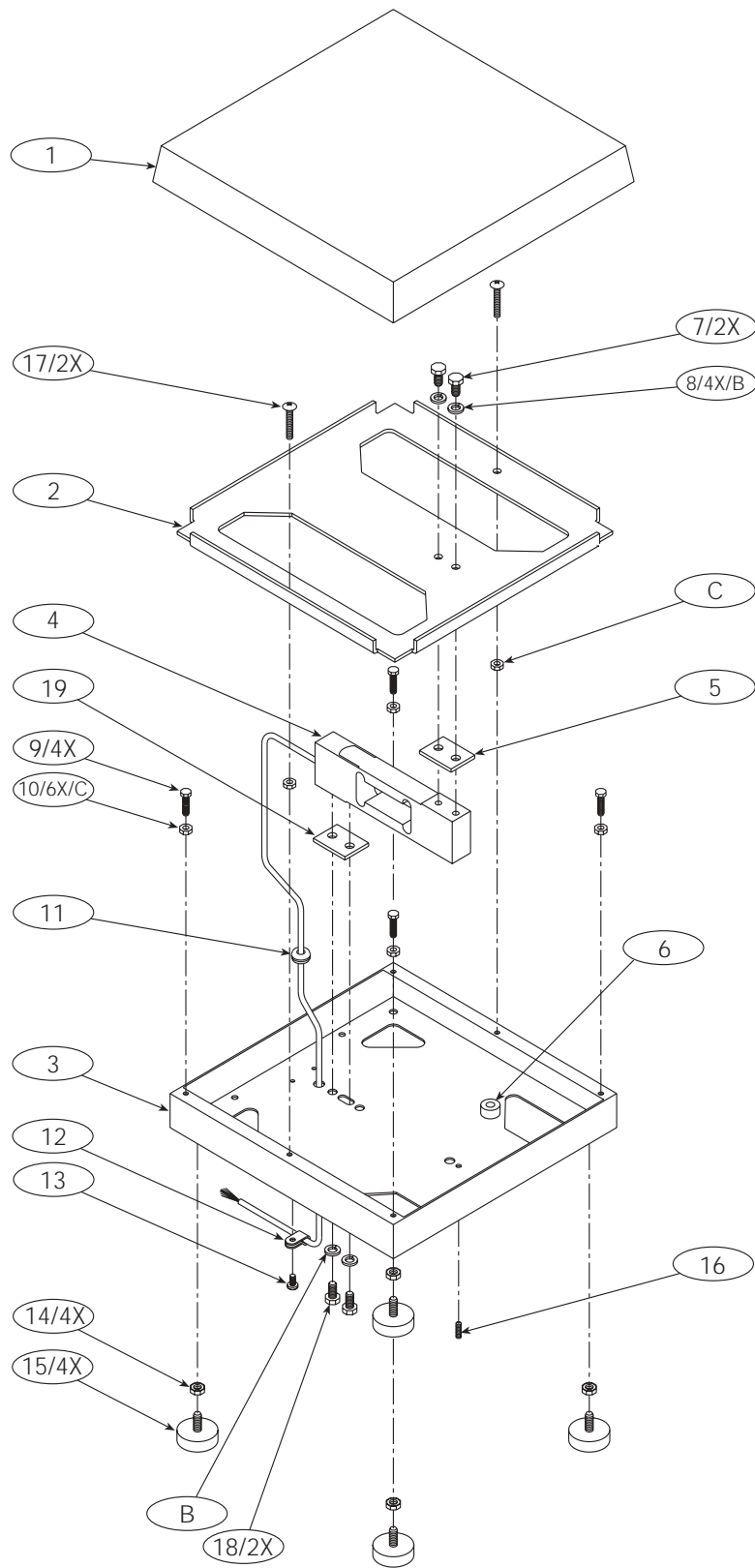

Figure 6-12. RL2100 Bench Scale Assembly

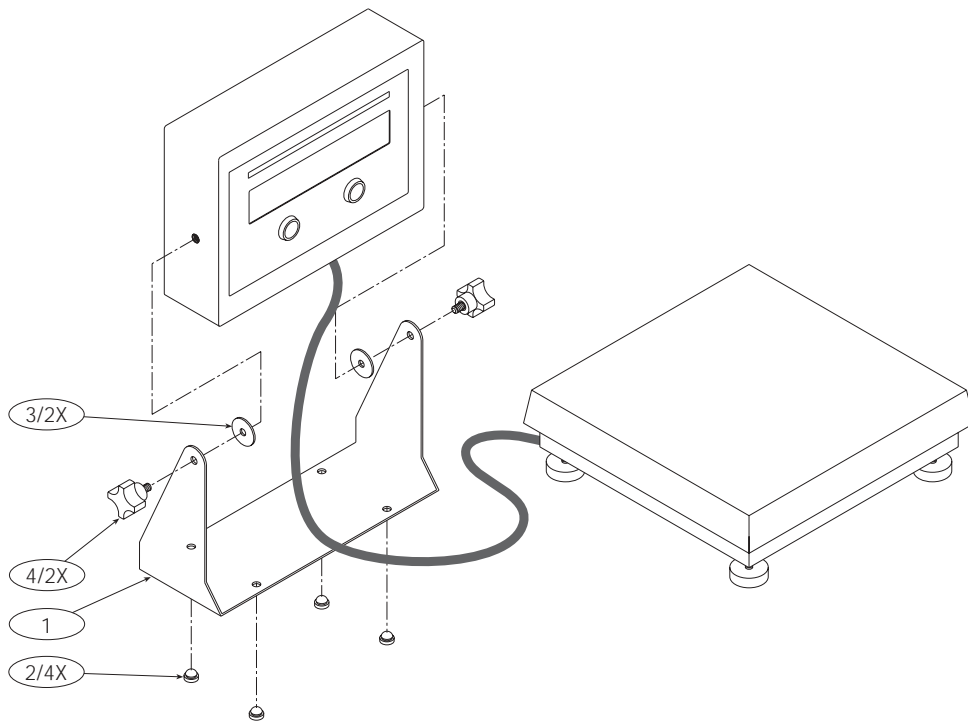

Figure 6-13. RL2100 Tilt Stand Assembly

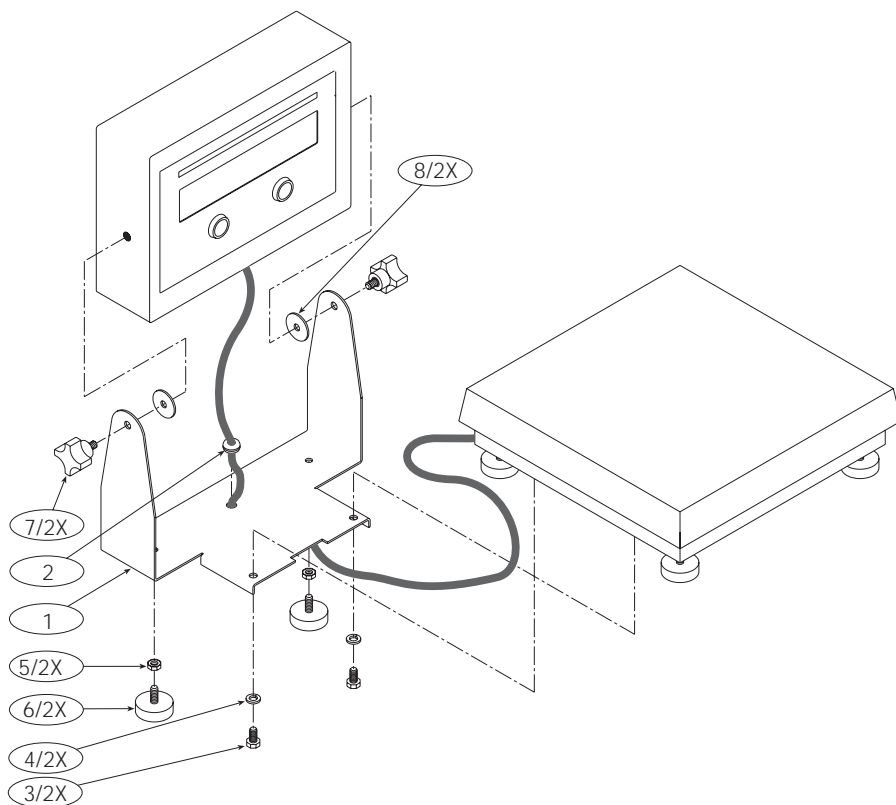

Figure 6-14. RL2100 Attachment Bracket Assembly

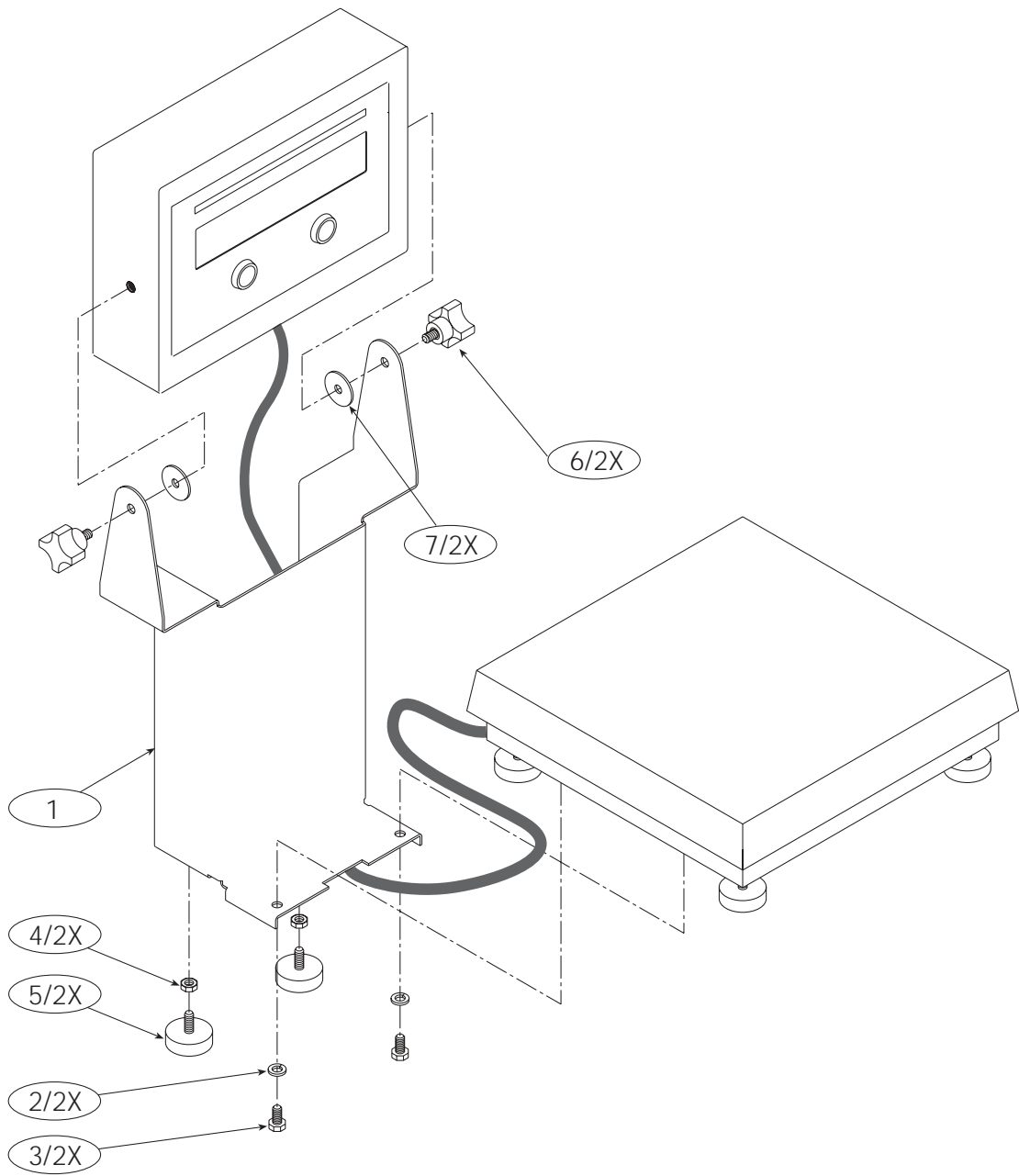

Figure 6-15. RL2100 Column Assembly

## 6.0 Appendix

### 6.1 Error Messages

The IQ plus 210 indicator provides a number of error messages. When an error occurs, the message is shown on the indicator LED display. Error conditions can also be checked remotely by using the XE EDP command as described in Section 6.1.2.

Error Message	Description	Solution
E A/D	A/D physical error	Call Rice Lake Weighing Systems (RLWS) Service.
EEEROM	EEPROM physical error	
EVIREE	Virgin EEPROM	Use the DEFLT menu to restore defaults, then recalibrate load cells.
EPCKSM	Parameter checksum error	
EACKSM	A/D calibration checksum error	A/D converter requires recalibration. Call RLWS Service.
ELCKSM	Load cell calibration checksum error	Recalibrate load cells.
EIDATA	Internal RAM checksum error	Call RLWS Service.
INOVFL	Internal overflow error	Remove weight from scale. If error recurs, check configuration, check scale for damage.
OVERFL	Overflow error	Weight value too large to be displayed.
-----	Gross > overload limit	Gross value exceeds overload limit. Check configuration.
-----	A/D underrange	A/D reading < -4 mV. Check scale for binding or damage.

Table 6-1. IQ plus 210 Error Messages

#### 6.1.1 Displayed Error Messages

The IQ plus 210 provides a number of front panel error messages to assist in problem diagnosis. Table 6-1 lists these messages and their meanings.

#### 6.1.2 Using the XE EDP Command

The XE EDP command can be used to remotely query the IQ plus 210 for the error conditions shown on the front panel. The XE command returns two 5-digit numbers in the format:

xxxxx yyyy

where xxxxx contains a decimal representation of an existing error conditions as described in Table 6-2.

If more than one error condition exists, the number returned is the sum of the values representing the error conditions. For example, if the XE command returns the number 528, this value represents the sum of an A/D physical error (512) and an A/D calibration checksum error (16).

The second number returned (yyyy) uses the same bit assignments as shown in Table 6-2 to indicate whether the test for the error condition was run. For example, the value yyyy = 51807 represents the decimal equivalent of the binary value 1100 1110 0111 1111. Using the bit assignments in Table 6-2, this value indicates all tests were run.

Error Code	Description	Binary Value
0	No error	0000 0000 0000 0000
1	EEPROM physical error	0000 0000 0000 0001
2	Virgin EEPROM	0000 0000 0000 0010
4	Parameter checksum error	0000 0000 0000 0100
8	Load cell calibration checksum error	0000 0000 0000 1000
16	A/D calibration checksum error	0000 0000 0001 0000
32	<i>not assigned</i>	0000 0000 0010 0000
64	Internal RAM checksum error	0000 0000 0100 0000
128	<i>not assigned</i>	0000 0000 1000 0000
256	<i>not assigned</i>	0000 0001 0000 0000
512	A/D physical error	0000 0010 0000 0000
1024	<i>not assigned</i>	0000 0100 0000 0000
2048	Internal overflow error	0000 1000 0000 0000
4096	<i>not assigned</i>	0001 0000 0000 0000
8192	<i>not assigned</i>	0010 0000 0000 0000
16384	A/D underrange	0100 0000 0000 0000
32768	Gross > overload limit	1000 0000 0000 0000

Table 6-2. Error Codes Returned on XE Command

## 6.2 Status Messages

Two EDP commands, P and ZZ, can be used to provide status about the indicator. These commands are described in the following sections.

### 6.2.1 Using the P EDP Command

The P EDP command returns the current displayed weight value to the EDP port. If the indicator is in an underrange or overload condition, the weight value is replaced with &&&&&& (overload) or ::::: (underrange).

### 6.2.2 Using the ZZ EDP Command

The ZZ EDP command can be used to remotely query which annunciators are currently displayed on the indicator front panel. The ZZ command returns the currently displayed weight and a decimal number representing the LED annunciators currently lit. The format of the returned data is:

**wwwwww**      **zzz**

where **wwwwww** is the current displayed weight, **zzz** is the annunciator status value (see Table 6-3). If more than one annunciator is lit, the second number returned is the sum of the values representing the active annunciators.

For example, if the annunciator status value returned on the ZZ command is 136, the center of zero and lb annunciators are lit: 136 represents the sum of the values for the center of zero annunciator (128) and the lb annunciator (8).

Decimal Value	Annunciator
1	Reserved
2	Negative value
4	oz
8	lb
16	g
32	kg
64	Motion
128	Center of zero

Table 6-3. Status Codes Returned on the ZZ Command

## 6.3 Continuous Output (Stream) Format

Figure 6-1 shows the continuous output format sent to the IQ plus 210 EDP or printer port when the STREAM parameter (SERIAL menu) is set to either EDP or PRN.

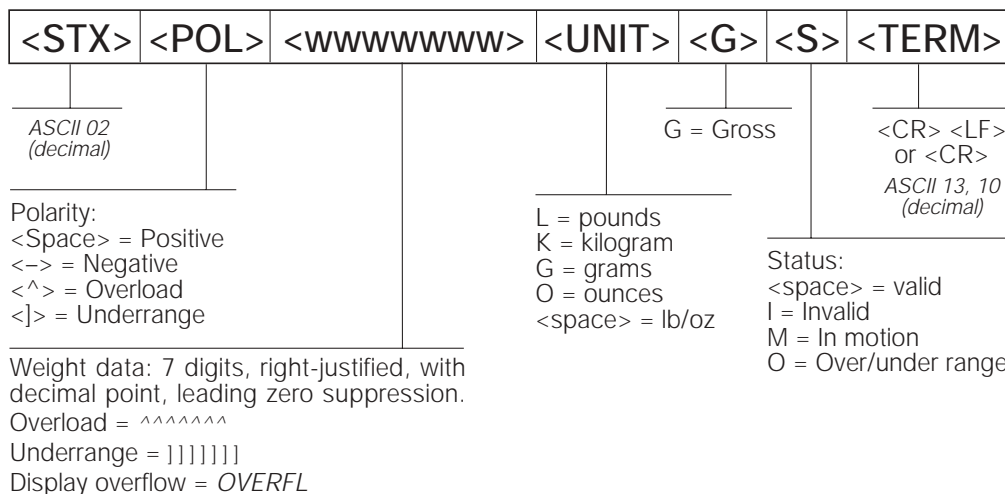

Figure 6-1. Continuous Output Data Format

## 6.4 Specifications

### 6.4.1 IQ plus 210 Indicator

#### Power

Line Voltages	115 or 230 VAC
Frequency	50 or 60 Hz
Power Consumption	70 mA @ 115 VAC (8W) 35 mA @ 230 VAC (8W)

#### Fusing

115 VAC	2 x 200 mA TR5 subminiature fuses Wickmann Time-Lag 19374 Series UL Listed, CSA Certified
230 VAC	2 x 100 mA TR5 subminiature fuses Wickmann Time-Lag 19372 Series UL Recognized, VDE Approved

#### Analog Specifications

Full Scale Input Signal	Up to 35 mV
Excitation Voltage	10 ± 0.25 VDC, 4 x 350Ω load cells
Analog Signal Input Range	0.6 mV/V – 4.5 mV/V
Analog Signal Sensitivity	0.3 μV/graduation minimum, 1.5 μV/grad recommended
Input Impedance	200 MΩ, typical
Display Resolution	10 000 dd
Input Sensitivity	155 nV per internal count
System Linearity	Within 0.01% of full scale
Calibration Method	Software, constants stored in EEPROM
Common Mode Voltage	–1.05 to +0.95 V, referred to earth
RFI Protection	Signal, excitation, and sense lines protected by capacitor bypass

#### Digital Specifications

Digital Inputs	2 inputs, TTL or switch closure, active-low
Digital Filter	Software selectable

#### Serial Communications

Serial Port	Full duplex RS-232; 9600, 4800, 2400, 1200 bps; 7 or 8 data bits; even, odd, or no parity
-------------	---

#### Operator Interface

Display	6-digit LED display. 7-segment, .8 in (20 mm) digits
LED annunciators	Negative value, center of zero, motion, kg, g, lb, oz
Keypad	2 piezo switches

#### Environmental

Operating Temperature	–10 to +40°C (legal); –10 to +50°C (industrial)
Storage Temperature	–25 to +70°C
Humidity	0–95% relative humidity
Altitude	2000 m (6500 ft) maximum

#### Enclosure

Enclosure Dimensions	9.5 in x 6 in x 2.75 in 24 cm x 15 cm x 7 cm
Weight	6.1 lb (2.8 Kg)
Rating/Material	NEMA 4X/IP66, stainless steel

#### Approvals



##### NTEP

CoC Number	00-045
Accuracy Class	III/III L



##### UL

File Number	E151461
-------------	---------

#### Measurement Canada Approved

Approval	AM-5374
Accuracy Class	III/III HD

### 6.4.2 RL2100 Bench Scale

#### Load Cells

RL1042 aluminum load cell (standard)	
RL1380 stainless steel load cell (optional)	
Rated Output	2.0 mV/V
Maximum Overload	150%
Cable	10 ft (3.1 m)
Output Impedance	350Ω, nominal
Operating Temperature	–10 to +40°C (legal); –10 to +50°C (industrial)
Storage Temperature	–25 to +70°C

#### Dimensions & Capacities

Base Dimension	Capacity
10 in x 10 in (254 mm x 254 mm)	5 lb (2.5 Kg) 10 lb (5 Kg) 25 lb (10 Kg)
12 in x 12 in (305 mm x 305 mm)	50 lb (25 Kg) 100 lb (50 Kg)

#### Approvals



##### NTEP

CoC Number	95-072A2
Accuracy Class	III

#### Measurement Canada Approved

Approval	AM-5082 Rev 1
----------	---------------

## IQ plus 2100 Limited Warranty

---

Rice Lake Weighing Systems (RLWS) warrants that all RLWS equipment and systems properly installed by a Distributor or Original Equipment Manufacturer (OEM) will operate per written specifications as confirmed by the Distributor/OEM and accepted by RLWS. All systems and components are warranted against defects in materials and workmanship for two years.

RLWS warrants that the equipment sold hereunder will conform to the current written specifications authorized by RLWS. RLWS warrants the equipment against faulty workmanship and defective materials. If any equipment fails to conform to these warranties, RLWS will, at its option, repair or replace such goods returned within the warranty period subject to the following conditions:

- Upon discovery by Buyer of such nonconformity, RLWS will be given prompt written notice with a detailed explanation of the alleged deficiencies
- Individual electronic components returned to RLWS for warranty purposes must be packaged to prevent electrostatic discharge (ESD) damage in shipment. Packaging requirements are listed in a publication, *Protecting Your Components From Static Damage in Shipment*, available from RLWS Equipment Return Department.
- Examination of such equipment by RLWS confirms that the nonconformity actually exists, and was not caused by accident, misuse, neglect, alteration, improper installation, improper repair or improper testing; RLWS shall be the sole judge of all alleged non-conformities.
- Such equipment has not been modified, altered, or changed by any person other than RLWS or its duly authorized repair agents.
- RLWS will have a reasonable time to repair or replace the defective equipment. Buyer is responsible for shipping charges both ways.
- In no event will RLWS be responsible for travel time or on-location repairs, including assembly or disassembly of equipment, nor will RLWS be liable for the cost of any repairs made by others.

**THESE WARRANTIES EXCLUDE ALL OTHER WARRANTIES, EXPRESSED OR IMPLIED, INCLUDING WITHOUT LIMITATION WARRANTIES OF MERCHANTABILITY OR FITNESS FOR A PARTICULAR PURPOSE. NEITHER RLWS NOR DISTRIBUTOR WILL, IN ANY EVENT, BE LIABLE FOR INCIDENTAL OR CONSEQUENTIAL DAMAGES.**

**RLWS AND BUYER AGREE THAT RLWS'S SOLE AND EXCLUSIVE LIABILITY HEREUNDER IS LIMITED TO REPAIR OR REPLACEMENT OF SUCH GOODS. IN ACCEPTING THIS WARRANTY, THE BUYER WAIVES ANY AND ALL OTHER CLAIMS TO WARRANTY.**

**SHOULD THE SELLER BE OTHER THAN RLWS, THE BUYER AGREES TO LOOK ONLY TO THE SELLER FOR WARRANTY CLAIMS.**

**NO TERMS, CONDITIONS, UNDERSTANDING, OR AGREEMENTS PURPORTING TO MODIFY THE TERMS OF THIS WARRANTY SHALL HAVE ANY LEGAL EFFECT UNLESS MADE IN WRITING AND SIGNED BY A CORPORATE OFFICER OF RLWS AND THE BUYER.**

© 2012 Rice Lake Weighing Systems, Inc. Rice Lake, WI USA. All Rights Reserved.

RICE LAKE WEIGHING SYSTEMS • 230 WEST COLEMAN STREET • RICE LAKE, WISCONSIN 54868 • USA









230 W. Coleman St. • Rice Lake, WI 54868 • USA  
U.S. 800-472-6703 • Canada/Mexico 800-321-6703  
International 715-234-9171

**[www.ricelake.com](http://www.ricelake.com)**  
**[mobile: m.ricelake.com](http://m.ricelake.com)**

© 2011 Rice Lake Weighing Systems

PN 53415 11/2011