

# MSI-4260 PORT-A-WEIGH

DIGITAL CRANE SCALE



## COMPATIBLE WITH:



MSI-8000 RF Remote Display



MSI ScaleCore Webservice



MSI-8004HD Remote Display



Rugged Remote Controller



MSI-8000HD RF Remote Display

**RICE LAKE**<sup>®</sup>  
WEIGHING SYSTEMS

800-472-6703

[www.ricelake.com](http://www.ricelake.com)

# MSI-4260

# PORT-A-WEIGH

## DIGITAL CRANE SCALE

### The industry's standard for accurate, reliable and safe overhead weighing.

After three decades of production, added advancements and thousands of worldwide installations, the next generation Port-A-Weigh embedded with ScaleCore<sup>®</sup> technology continues to reign as the industry standard. Along with Port-A-Weigh, the MSI brand features the most comprehensive line of industrial crane scales and specialized overhead weighing solutions.

#### Options and Accessories

- NTEP and Measurement Canada Certified (70k and under), MC Approved (5k and under)
- Rugged Remote (typical range 50 ft / 15 m)
- Dual RF Modem Links for wireless connectivity with optional remote devices
- Universal direct power supply: 85-265 VAC, 47-440 Hz/130-300 VDC
- Heat shield for hot metal and high temperature applications (contact factory for operating specifications)
- Substitute shackle for bottom swivel hook (for possible headroom loss reduction)
- Oversized top lifting eye or shackle (for oversized crane hook interface)
- 802.11b/g wireless module
- Retrofit Kit: Upgrade previous MSI-4260 to new generation MSI-4260 with ScaleCore
- Optional FM and ATEX approvals for applications requiring Intrinsic Safety

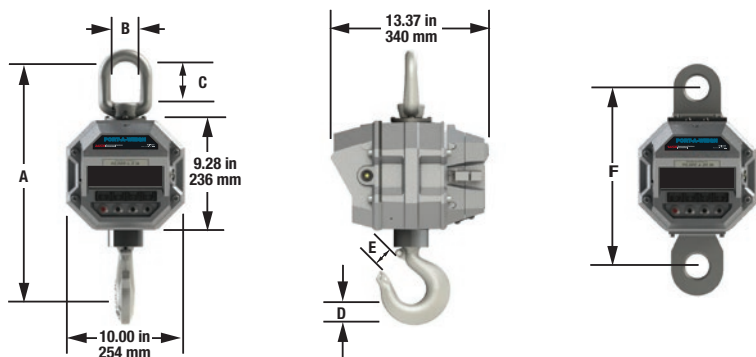

#### SPECIFICATIONS

<b>ACCURACY:</b>	± (0.1% +1 d) of applied load
<b>RESOLUTION:</b>	3,000 to 5,000 d standard (up to 10,000 d available)
<b>ENCLOSURE:</b>	NEMA Type 4, IP66 marine grade 356 alloy anodized cast aluminum
<b>LIFTING EYE, SHACKLE &amp; HOOK:</b>	Crosby <sup>®</sup> or equal with 360° thrust-bearing swivel hook
<b>DESIGN OVERLOAD:</b>	200% safe / 500% ultimate (except as noted)
<b>FUNCTIONS:</b>	Power: Turns Unit ON or OFF Zero: Zeros applied load up to 100% of capacity (limited range in NTEP/OIML configurations) Tare: Tares applied load and displays weight in net mode F1: Programmable as TEST, UNITS, NET/GROSS, TOTAL & PEAK HOLD
<b>DISPLAY:</b>	Five-digit, 1.2 in (30 mm) LED, 3 colors (programmable)
<b>DISPLAYABLE UNITS:</b>	Pounds or kilograms selectable
<b>ANNUNCIATORS:</b>	CO <sub>2</sub> , net, gross, total, peak, low battery, lb/kg, motion, setpoints
<b>POWER:</b>	12 volt rechargeable battery 115/230 VAC battery charger is included
<b>OPERATING TIME:</b>	Up to 200 hours between charging with typical use Less with optional RF modem link
<b>OPERATING TEMPERATURE:</b>	-40 degrees F to 122 degrees F (-40 degrees C to 50 degrees C)
<b>AUTO-OFF MODE:</b>	Select for 15, 30, 45 minutes, 1 hour or off
<b>AUTO SLEEP MODE:</b>	Power down during non-use and power up with weight change or any key press
<b>SERVICE COUNTERS:</b>	Counts number of lifts over percentage of capacity and lifts over capacity
<b>CALIBRATION:</b>	Digital
<b>FILTERING:</b>	OFF, LO, HI-1, HI-2 selectable

#### MSI-8000 RF REMOTE DISPLAY SPECIFICATIONS

<b>FUNCTIONS:</b>	On/off, zero, tare, peak hold, units, total, high resolution, net/gross, print, test
<b>DISPLAY:</b>	Five-digit, 1.22 in (31 mm) LCD
<b>POWER:</b>	Rechargeable lithium polymer battery 24 hours operating time between charging in typical use 115/230 VAC battery charger is included
<b>RF FREQUENCY:</b>	2.4 GHz - 802.15.4 operating range 100 ft (30 m) typical
<b>ENCLOSURE:</b>	Industrial grade NEMA type 4/IP65
<b>OUTPUT:</b>	Serial RS-232



Capacity	Resolution**	A*	B*	C*	D*	E*	F	Hook	Eye Nut or Shackle	Safety Factor	Shipping Wt
500 lb (250 kg)	0.2 lb (0.1kg)	18.3 in (465 mm)	2.25 in (57.1mm)	3.06 in (77.7 mm)	1.44 in (37.0 mm)	1.41 in (36.0 mm)	-	5 ton alloy swivel	CR # 7 eye nut	>5	53 lb (24 kg)
2,000 lb (1,000 kg)	1 lb (0.5 kg)	18.3 in (465 mm)	2.25 in (57.1mm)	3.06 in (77.7 mm)	1.44 in (37.0 mm)	1.41 in (36.0 mm)	-	5 ton alloy swivel	CR # 7 eye nut	>5	53 lb (24 kg)
5,000 lb (2,500 kg)	1 lb (0.5 kg)	20.5 in (521 mm)	2.50 in (64.0 mm)	3.50 in (89.0 mm)	1.81 in (46.0 mm)	1.69 in (42.9 mm)	-	7 ton alloy swivel	CR # 8 eye nut	>5	62 lb (28 kg)
10,000 lb (5,000 kg)	2 lb (1kg)	20.5 in (521 mm)	2.50 in (64.0 mm)	3.50 in (89.0 mm)	1.81 in (46.0 mm)	1.69 in (42.9 mm)	-	7 ton alloy swivel	CR # 8 eye nut	>5	62 lb (28 kg)
20,000 lb (10,000 kg)	5 lb (2 kg)	28.5 in (724 mm)	4.00 in (101.6 mm)	6.25 in (159 mm)	2.62 in (66.5 mm)	2.41 in (61.2 mm)	-	15 ton alloy swivel	CR #11 eye nut	>7 (>6.5)	105 lb (47 kg)
30,000 lb (15,000 kg)	10 lb (5 kg)	30.0 in (762 mm)	4.00 in (101.6 mm)	6.25 in (159 mm)	3.00 in (76.2 mm)	3.19 in (81.0 mm)	-	22 ton alloy swivel	CR #11eye nut	>5	125 lb (55 kg)
50,000 lb (25,000 kg)	10 lb (5 kg)	41.0 in (1,041 mm)	5.00 in (127 mm)	6.00 in (152 mm)	3.62 in (92.0 mm)	3.63 in (92.0mm)	15.0 in (381 mm)	30 ton alloy swivel	CR 25 ton shackle # 2130	>54.9***	235 lb (106 kg)
70,000 lb (35,000 kg)	20 lb (10 kg)	43.2 in (1097 mm)	5.00 in (127 mm)	6.00 in (152 mm)	4.56 in (116 mm)	3.75 in (95.0 mm)	15.0 in (381 mm)	37 ton alloy swivel	CR40 ton alloy shackle # 2140	4.75**** 4.3****	270 lb (121 kg)
100,000 lb (50,000 kg)	20 lb (10 kg)	52.1 in (1324 mm)	5.75 in (146 mm)	6.65 in (169 mm)	5.06 in (129 mm)	4.25 in (108 mm)	16.25 in (413 mm)	45 ton alloy swivel	CR 55 ton alloy shackle # 2140	4.5***** 4*****	420 lb (189 kg)
								60 ton alloy swivel	CR 55 ton alloy shackle # 2140	5 (4.5)	510 lb (231 kg)
								75 ton alloy swivel	CR 55 ton alloy shackle # 2140	5 (4.5)	630 lb (286 kg)

Alternate Hooks for 100,000 lb

CR = Crosby or equivalent. (Crosby is a registered trademark of The Crosby Group, LLC.)  
 \*\* These dimensions also apply to 50/70/100,000lb models with hook and shackle  
 \*\*\* Resolution subject to change for NTEP Certified units  
 \*\*\*\* Ultimate overload: 490% of kg capacity  
 \*\*\*\*\* Ultimate overload: 475% of lb capacity / 430% of kg capacity  
 \*\*\*\*\* Ultimate overload: 450% of kg capacity

SALES AND TECHNICAL ASSISTANCE



**HEADQUARTERS**  
 230 West Coleman Street  
 Rice Lake, Wisconsin 54868 - USA  
 Tel: (715) 234 9171 | Fax: (715) 234 6967  
 www.ricelake.com