

# MSI-8004HD

*RF Indicator*

## Technical Manual



An ISO 9001 registered company  
© Rice Lake Weighing Systems. All rights reserved.

Rice Lake Weighing Systems® is a registered trademark of  
Rice Lake Weighing Systems.  
All other brand or product names within this publication are trademarks or  
registered trademarks of their respective companies.

All information contained within this publication is, to the best of our knowledge, complete and accurate at the time of publication. Rice Lake Weighing Systems reserves the right to make changes to the technology, features, specifications and design of the equipment without notice.

The most current version of this publication, software, firmware and all other product updates can be found on our website:

[www.ricelake.com](http://www.ricelake.com)

# Contents

1.0	Introduction .....	1
1.1	Features .....	1
1.2	Safety .....	2
1.3	Front Panel Description .....	3
1.3.1	Key/Annunciator Functions .....	3
1.4	System Configurations .....	4
1.5	Options .....	4
2.0	Operation .....	5
2.1	Power .....	5
2.2	Zero .....	5
2.3	Tare .....	5
2.3.1	Tare and Display the Net Load .....	5
2.3.2	Clear Tare and Revert to Gross Load .....	5
3.0	Installation .....	6
3.1	Unpacking .....	6
3.2	Getting Started .....	6
3.3	Mounting the <i>MSI-8004HD</i> .....	6
3.4	Opening the Enclosure .....	7
3.5	Wiring/Connections .....	8
3.5.1	Connect Load Pins .....	8
3.5.2	Power Supply .....	9
3.6	RF Card Replacement .....	10
3.7	ScaleCore Card Replacement .....	11
3.8	Antenna Replacement .....	11
3.9	Tilt Stand .....	12
3.10	Battery Option .....	12
3.10.1	Battery Life .....	12
3.10.2	Battery Charger .....	13
3.10.3	Install Battery Option .....	13
3.10.4	Replace Battery .....	14
3.11	Parts Illustrations .....	15
3.11.1	MSI-8004HD Indicator .....	15
3.11.2	Tilt Stand .....	17
3.11.3	Battery Option .....	18
4.0	Setup .....	19
4.1	Setup Menu .....	19
4.2	Function Keys .....	21
4.2.1	Test .....	21
4.2.2	Total .....	22
4.2.3	Net/Gross .....	22
4.2.4	Peak Hold .....	22
4.2.5	Units .....	22
4.2.6	Hi-Res .....	23
4.2.7	Print .....	23
4.3	Auto-Off .....	23
4.4	Sleep .....	24
4.5	Display Brightness .....	24
4.6	Setpoints .....	25



Technical training seminars are available through Rice Lake Weighing Systems. Course descriptions and dates can be viewed at [www.ricelake.com/training](http://www.ricelake.com/training) or obtained by calling 715-234-9171 and asking for the training department.

# Contents

4.7	Output	26
4.8	Total Mode	27
4.9	Filter	28
4.10	Unit	28
4.11	Battery Life – Optional	29
4.12	Standard Settings	29
5.0	Calibration	30
5.1	Calibration Switch	30
5.2	Reset the Load Pin Calibration	30
5.3	Initial Calibration	31
5.3.1	Routine Calibration	31
5.3.2	C-Cal Calibration	32
5.4	Setup	33
5.4.1	Standard Settings	34
5.5	Reset the Load Pin Calibration	34
6.0	Communications Setup	35
6.1	Communications Menu	35
6.1.1	Control Modes	36
6.1.2	Standard Print Strings	36
6.1.3	Printer Output Setup	37
6.2	RF Setup	38
6.3	Setup Multiple Sensor Network	40
6.3.1	Load Totaling Settings	41
6.3.2	Scan Weight Inputs	42
6.4	Zero and Tare in Multiple Load Pin Systems	42
6.5	Communications Port Hardware	42
6.6	Relays	44
6.6.1	Relay Options	44
6.6.2	Extended Relay Kit – Optional	45
6.7	FCC Statement	45
6.8	International RF Certifications	45
6.9	Antenna Options	46
6.9.1	Standard Antenna	47
6.9.2	Long Range OMNI 9 dBi Antenna	47
6.9.3	Vehicle Mount Whip Antenna	47
6.9.4	YAGI Antenna	47
6.9.5	Corner Reflector Antenna	47
6.9.6	Patch Antenna	47
7.0	Troubleshooting and Maintenance	48
7.1	Troubleshooting	48
7.2	Error Codes	49
7.3	Service Counters	49
7.3.1	Access the Service Counters	49
7.4	Mechanical Dimensions	50
7.5	Firmware Update	50
8.0	Specifications	52



Rice Lake continually offers web-based video training on a growing selection of product-related topics at no cost. Visit [www.ricelake.com/webinars](http://www.ricelake.com/webinars)

# 1.0 Introduction

---

The *MSI-8004HD RF Indicator* is a combination of the sound and proven mechanical design of the industry standard, with today's most advanced electronics. It provides a superb feature set unmatched by any scale in its class or price range. The *MSI-8004HD* is versatile, reliable, accurate and easy to operate. RF remote control and remote display options are available to further enhance the safety and usability. Installed optional relays optimize work-flow and process control.

This manual is intended for use by qualified technicians responsible for setting up and operating the *MSI-8004HD*.



Manuals are available for viewing and/or downloading from the Rice Lake Weighing Systems website at [www.ricelake.com/manuals](http://www.ricelake.com/manuals)

Warranty information can be found on the website at [www.ricelake.com/warranties](http://www.ricelake.com/warranties)

## 1.1 Features

- Meets or exceeds U.S./International safety and environmental standards
- No license required. Meets U.S./International RF transmission laws
- The display enclosure is pending IP65, for outdoor use
- The enclosure is built with rugged construction throughout
- Six, 1.5" (38 mm), LED digits for clear weight readings
- Selectable units for kg or lb
- Automatic or manual weight totalization for loading operations
- Eight setpoints can be set for in-range load/weight value for operator alerts or process control
- ScaleCore technology provides quick and easy firmware updates and calibration/setup backup
- Optional hard-wired link for applications where RF is not allowed



## 1.2 Safety

### Safety Signal Definitions:



Indicates an imminently hazardous situation that, if not avoided, will result in death or serious injury. Includes hazards that are exposed when guards are removed.



Indicates a potentially hazardous situation that, if not avoided, could result in serious injury or death. Includes hazards that are exposed when guards are removed.



Indicates a potentially hazardous situation that, if not avoided, could result in minor or moderate injury.



Indicates information about procedures that, if not observed, could result in damage to equipment or corruption to and loss of data.

### General Safety



Do not operate or work on this equipment unless this manual has been read and all instructions are understood. Failure to follow the instructions or heed the warnings could result in injury or death. Contact any Rice Lake Weighing Systems dealer for replacement manuals.



*Failure to heed could result in serious injury or death.*

*Do not allow minors (children) or inexperienced persons to operate this unit.*

*Do not stand near a load being lifted as it is a potential falling hazard. Keep a safe distance.*

*Do not use for purposes other than weight taking or dynamic load monitoring.*

*Do not use any load bearing component that is worn beyond five percent of the original dimension.*

*Do not use any associated lifting product if any of the load bearing components are cracked, deformed or show signs of fatigue.*

*Do not exceed the rated load limit of the associated scale/dynamometer unit, rigging element or the lifting structure.*

*Do not allow multi-point contact with the hook, shackle or lifting eye of the associated scale/Dynamometer unit.*

*Do not allow high torque on the scale/dynamometer unless it is specifically designed for high torque.*

*Do not make alterations or modifications to the unit or associated load bearing devices; any alterations void the warranty.*

*Do not remove or obscure warning labels.*

*There are no user serviceable parts within the MSI-8004HD. Any repairs must be performed by qualified service personnel only.*



## 1.3 Front Panel Description

The *MSI-8004HD* front panel keys and annunciators are described in [Table 1-1](#).

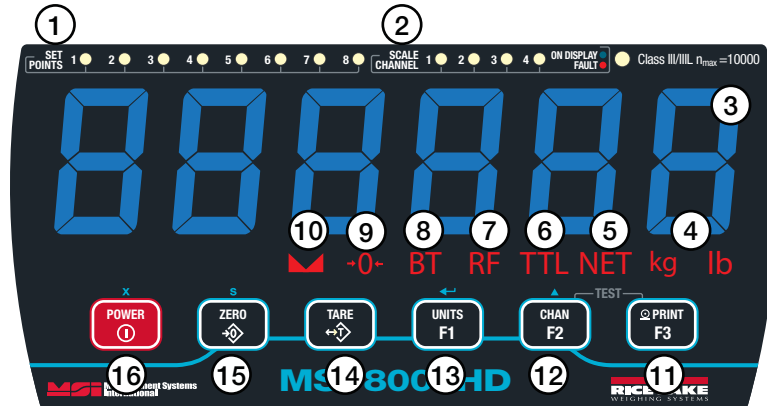

Figure 1-1. Front Panel

### 1.3.1 Key/Annunciator Functions

Item No.	Description
1	Setpoints — user programmable setpoints for overload warnings; they are green when set and flash red when tripped
2	Scale Channel — blue LED indicates the channel on display; if red, a fault is detected
3	Display Digits — includes six 1.5" (38 mm) sunlight visible LED's; Color - Blue or Red/Green/Orange
4	kg — indicates load display is in kilograms lb — indicates load display is in pounds
5	Net — RF linked device is in Net load mode; a tare weight is subtracted from the gross load
6	Total — RF linked device is displaying the total accumulated weight; a temporary display lasting less than 5 seconds
7	RF — indicates an active radio communication link with a scale or indicator
8	Low Battery — illuminates when approximately 10% of battery life remains, flashes when automatic shutdown is eminent
9	Center of Zero — indicates that the scale/Dyna-Link is within 1/4 d of zero
10	Standstill — load has settled within the motion window (usually $\pm 1d$ ); if off, the scale will not zero, tare or totalize
11	Function 3 Key — pre-programmed to Print and cannot be changed; performs diagnostic and display tests when pressed with Function 2 key
12	Function 2 Key — programmable to user selectable functions, see <a href="#">Section 4.0 on page 19</a> ; performs diagnostic and display tests when pressed with Function 3 key; Default <i>Channel</i>
13	Function 1 Key — programmable to user selectable functions, see <a href="#">Table 4.2 on page 21</a> ; Default <i>Units</i>
14	Tare Key — removes current weight and puts the system into <i>Net</i> weight mode
15	Zero Key — zeros the residual load on a scale/Dyna-Link
16	Power Key — turns the unit on and off

Table 1-1. Keypad/Annunciator Functions

See [Section 4.0 on page 19](#) for key functions when in setup menu.

## 1.4 System Configurations

The MSI-8004HD models and part numbers are listed below.

Part No	Description	Comments
178263	MSI-8004HD Indicator, 4CH AC, Blue	85~264VAC, 47~440Hz, 120~370VDC (add filter)
178265	MSI-8004HD Indicator, 4CH AC, Red/Green	85~264VAC, 47~440Hz, 120~370VDC (add filter)
178267	MSI-8004HD Indicator, 4CH DC, 8-32V, Blue	Best for external 12V SLA Batteries
178269	MSI-8004HD Indicator, 4CH DC 8-32V, Red/Green	Best for external 12V SLA Batteries
178270	MSI-8004HD Indicator, 4CH DC 9-36V Iso, Blue	Do not use on 12V Vehicle Systems
178271	MSI-8004HD Indicator, 4CH DC 9-36V Iso, Red/Green	Do not use on 12V Vehicle Systems
183480	MSI-8004HD Indicator, 4CH DC External Battery, Blue	
183481	MSI-8004HD Indicator, 4CH External Battery, Red/Green	

Table 1-3. Indicator Configurations

## 1.5 Options

Part No	Option	Description
133620	Serial Cable, 2' with DB9 female conn	
139309	Antenna Kit, Long Range Omni-directional, 9dBi with 3m Coax	Intended for omni-directional mast mounting (up to 2" Ø). Beam-width. Must be mounted vertically.
139310	Antenna Kit, Corner Reflector, 9dBi with 3m Coax	Intended for directional wall or mast mounting (up to 2" Ø). Beam-width: 75° Elevation, 65° Azimuth
139311	Antenna Kit, Corner Reflector, 12dBi with 3m Coax	Intended for directional wall or mast mounting (up to 2" Ø). Beam-width: 50° Elevation, 36° Azimuth
139312	Antenna Kit, YAGI, 15dBi with 3m Coax	Highly directional wall or mast mounting (up to 2" Ø). Beam-width: 30° Elevation, 34° Azimuth
139313	Antenna Kit, Vehicle Mount, 5dBi with 5m Coax	Omni-directional. Mounts in 3/4" Hole.
184043	Battery, 5V Li-ion	Replacement battery for use only with MSI-8004HD assemblies that support the external battery.
184044	Car Charger	Car charger for MSI-8004HD battery
--	Option Kit, Extended Relay	Allows for up to eight relays; see <a href="#">Section 6.6.2 on page 45</a>

Table 1-4. Available Options





## 2.0 Operation

This section covers the basic operation of the *MSI-8004HD*.

### 2.1 Power

Power the indicator On/Off by pressing .

### 2.2 Zero

Sets the zero reading of the scale to remove small deviations in zero when the unit is unloaded. See [Section 2.3](#) for zeroing (taring) a package, rigging or pallet weights.

Press . The weight must be stable in the motion window for the zero function to work.

- When using multiple scales, ensure the scale to be zeroed is displayed.
- The backup memory in the unit stores the tare reading, and can restore it even if power fails.
- Zero works in Gross or Net mode.
- Zeroing while in Net mode will zero the gross load causing the display to show a negative tare value.
- The scale must be stable within the motion window and  illuminated before it will zero. The scale remembers the zero request for two seconds. If a motion clears in that time, it will zero.
- The scale will accept a zero setting over the full range of the scale. Zero settings above 4% of full scale will subtract from the overall capacity of the scale.

*Example:*

*If 100 lb is zeroed on a 1000 lb scale, the overall capacity of the scale will reduce to 900 lb plus the allowed over-range amount.*

### 2.3 Tare

Tare is used to zero out a known weight such as rigging, a container or pallet and display the load in *Net* weight.

#### 2.3.1 Tare and Display the Net Load

1. Load the item that needs to be tared onto the scale.
2. Press . The weight display changes to 0 and *Net* is displayed.

#### 2.3.2 Clear Tare and Revert to Gross Load

Press . *Net* turns off indicating the unit is in gross mode.

- Only positive gross load readings can be tared
- Setting or changing the tare has no effect on the gross zero setting
- Taring will reduce the apparent over range of the scale

*Example:*

*When taring 100 lb of rigging on a 1000 lb scale, the scale will overload at a net load of 900 lb (1000-100) plus any additional allowed overload (usually about four percent or 9 d).*

To view the gross load without clearing the tare value, an F-key can be programmed to Net/Gross. See [Section 4.2.3 on page 22](#).

## 3.0 Installation

This section describes the installation of the *MSI-8004HD*.

### 3.1 Unpacking

Remove the *MSI-8004HD* from the packaging and inspect for visible damage. If damaged occurred during shipping, notify Rice Lake Weighing Systems and the shipper immediately.

Retain original packaging when possible, in the event that it needs to be returned, it must be properly packed with sufficient packing materials.

### 3.2 Getting Started

The *MSI-8004HD* is often shipped pre-configured with a scale. If purchased separately, or to be used with a different system, the RF transceivers will have to be paired. Follow the RF Setup Procedure in [Section 6.2 on page 38](#).

The system automatically connects with the scale once the RF setup is complete. A site survey is recommended to identify the RF Link's operating range and usability. Position the scale at an average operational height, and try the link at various positions and distances. The range may vary by the rotation of the scale/Dyna-Link, as well as the site and installation variables.

### 3.3 Mounting the *MSI-8004HD*

The provided tilt stand can be used to mount the *MSI-8004HD* to a wall or counter top.

It can also be mounted directly to a wall or panel using bolts in the mounting holes of the unit.



Figure 3-1. Mounting Holes

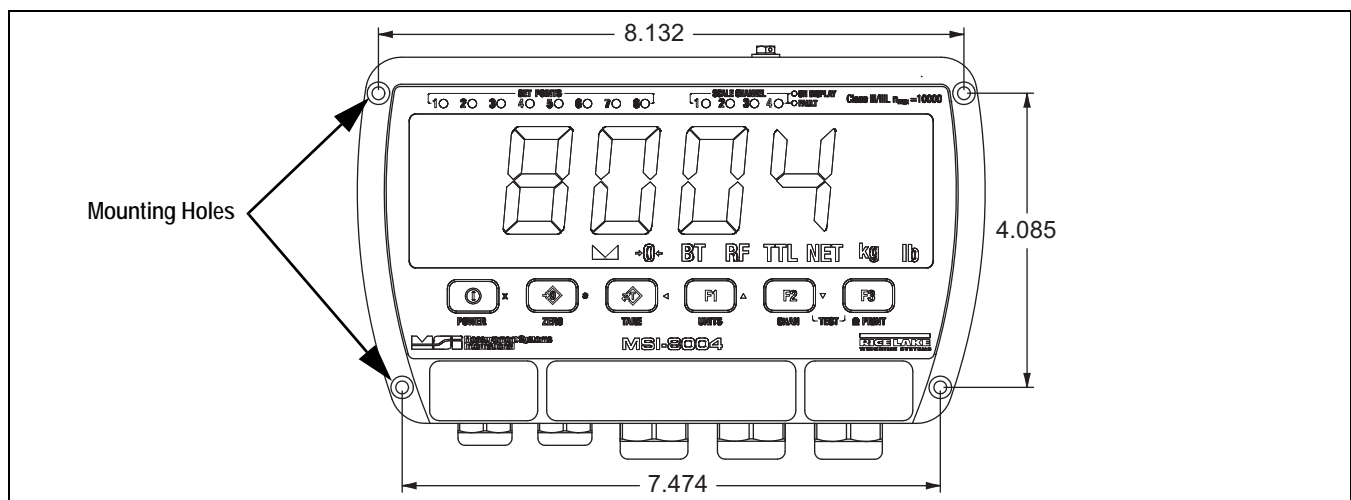

Figure 3-2. Mounting Holes with Dimensions

### 3.4 Opening the Enclosure

The indicator enclosure must be opened to connect the load pin cables and other interface connections.



*Before opening the unit, ensure the power is disconnected.*

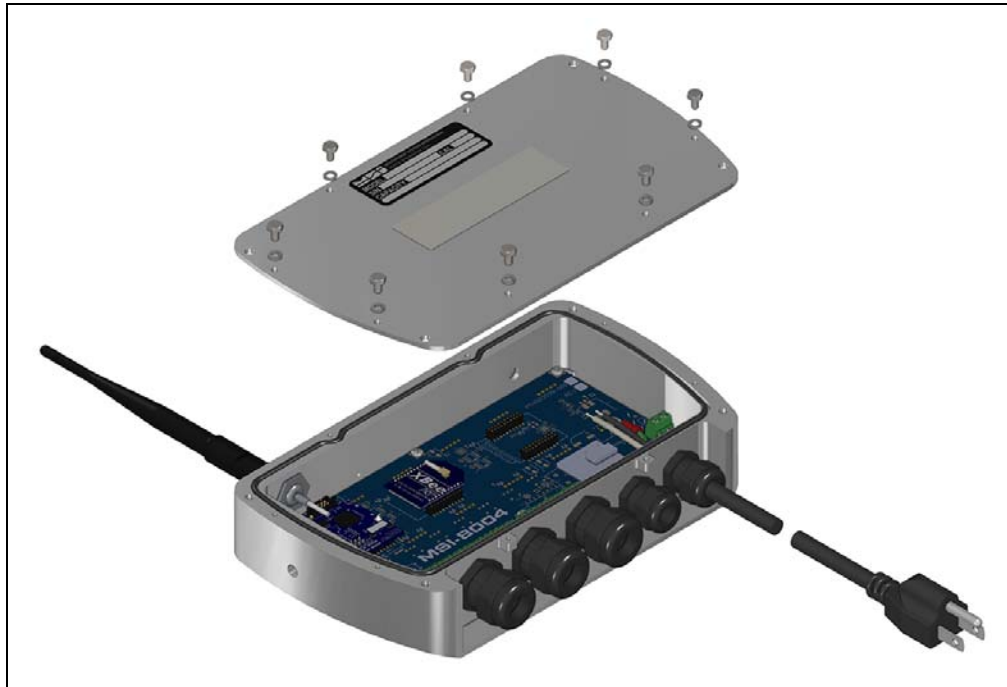

*Figure 3-3. Open Enclosure*

1. Place the indicator face down on an anti-static work mat.
2. Remove the screws securing the backplate to the enclosure. Retain for re-installation.
3. Remove the backplate to access the interior and set it aside.

## 3.5 Wiring/Connections

See [Section 6.5 on page 42](#) for wiring connections of the serial cable and printer.



**WARNING** Before opening the unit, ensure the power is disconnected.

### 3.5.1 Connect Load Pins

1. Remove backplate. See [Section 3.4](#).
2. Loosen the cable connectors and remove the pin.

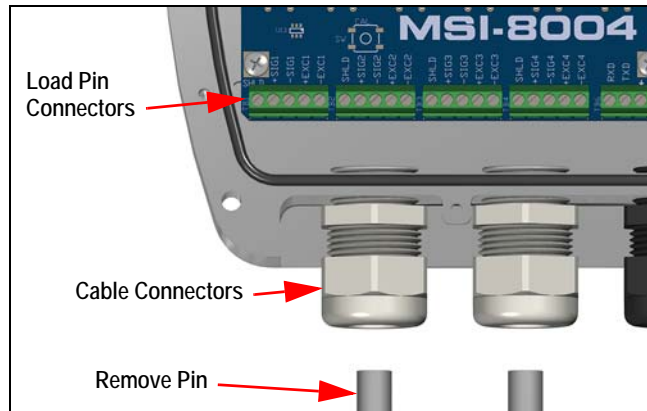

Figure 3-4. Load Pin Cable Connectors

3. If connecting four load pins, insert the two hole insert into the cable connectors.
4. Run load pin cables through the cable connectors into the indicator.
5. Loosen the screws in load pin connector.
6. Insert stripped end of each wire into the holes of the connector as indicated in [Figure 3-5](#).
7. Re-tighten screws to secure wires.

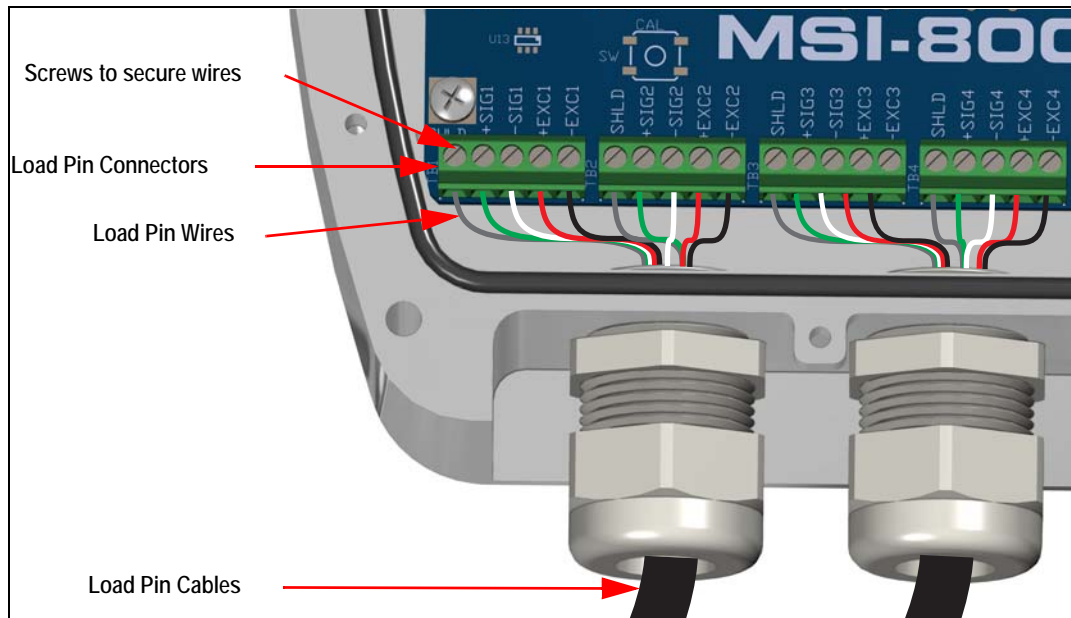

Figure 3-5. Install Load Pin Cables

8. Align the back plate on the enclosure and secure with screws.

**IMPORTANT**

The indicator must be calibrated once the load pins have been connected. See [Section 5.0 on page 30](#).



### 3.5.2 Power Supply

Both AC and DC power supply are available for the *MSI-8004HD*. See [Section 1.4 on page 4](#) for available configurations.



Ensure there is no power to the unit prior to opening the unit.

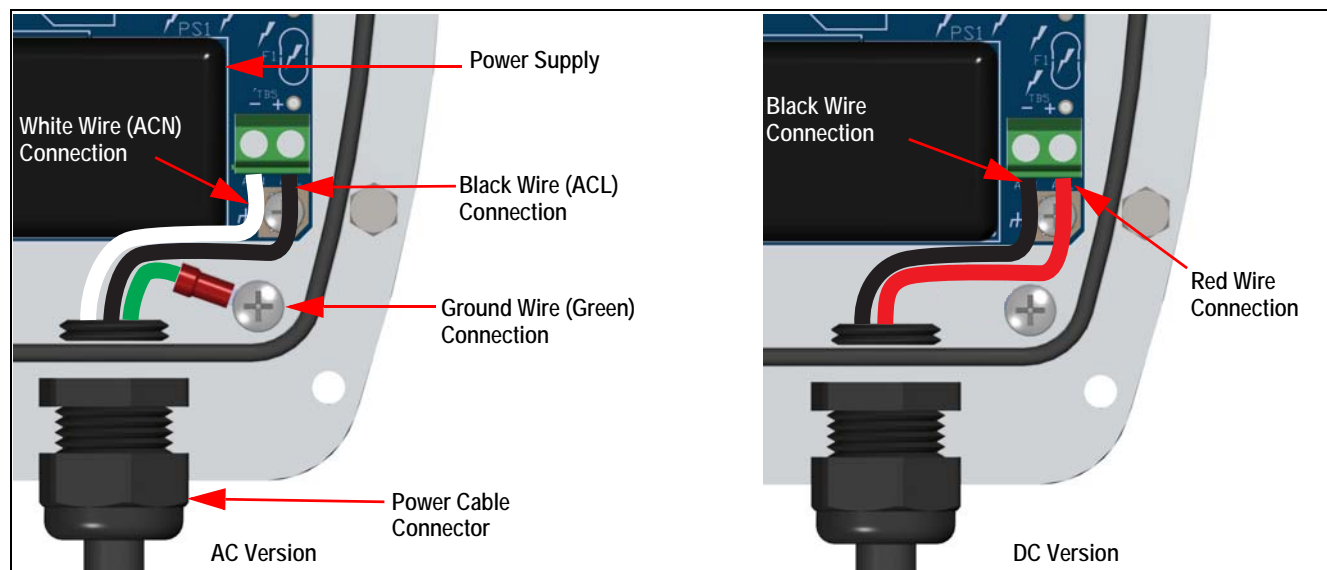

Figure 3-6. Power Supply

1. Remove backplate. See [Section 3.4 on page 7](#).
2. Loosen screws in the power wire connector to pull the wires from the connector.
3. Remove the screw securing the ground wire (AC Only).
4. Loosen the cable connector and pull the power cable from the enclosure.
5. Push new cable through the cable connector and reconnect wiring as shown in [Figure 3-6](#).
6. Ensure all connections are tight and reinstall the back plate.

## 3.6 RF Card Replacement

1. Remove backplate. See [Section 3.4 on page 7](#).

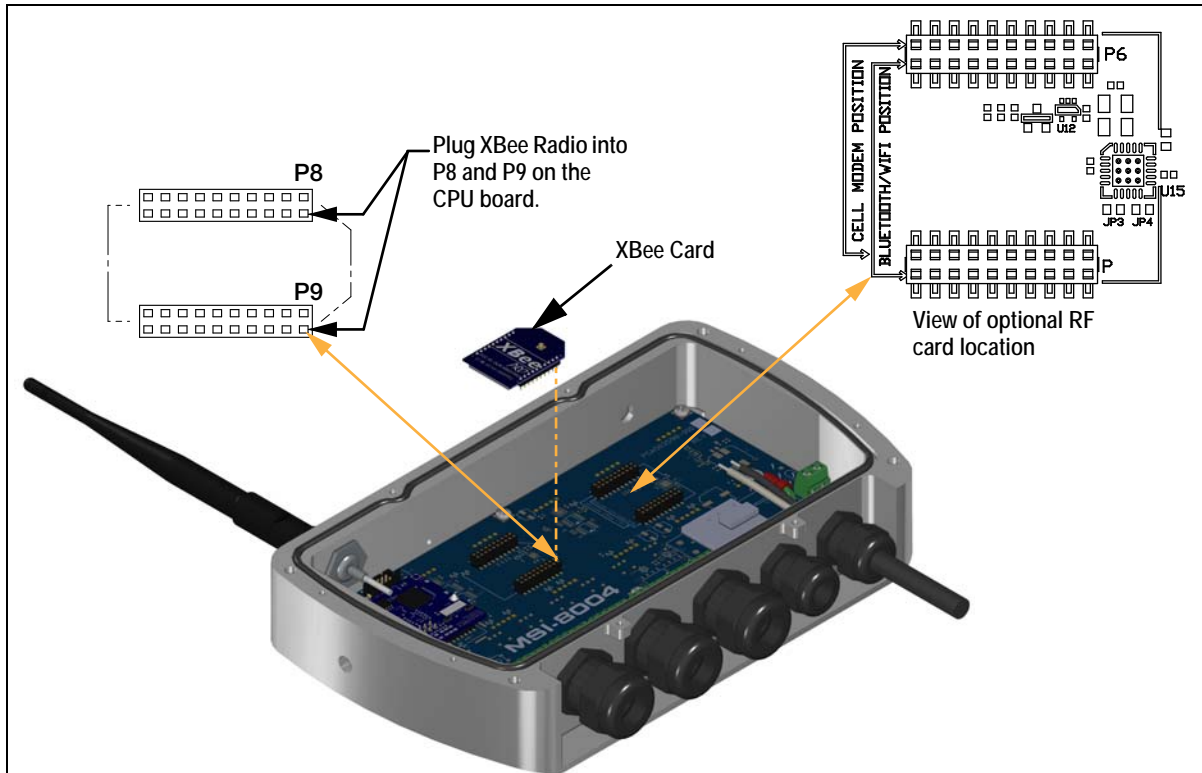

Figure 3-7. XBee Card Location

2. Disconnect the antenna wire from the XBee card.
3. Pull card up to remove from the CPU Board.
4. Align new card with the connection. Ensure it is in line with the correct holes. See [Figure 3-7](#).
5. Press card into place and reconnect the antenna wire.



**Note** The matching card must be installed in the attached scale. See the scale manual for instructions.

The *MSI-8004HD* can have two RF cards installed at a time. The other card can be Wi-Fi, Bluetooth or FHSS. If ordered with purchase of a system, it will be installed and paired to the scale included in the order. To order separate or for more information Contact Rice Lake Weighing Systems or a local dealer.

### 3.7 ScaleCore Card Replacement

1. Remove backplate. See [Section 3.4 on page 7](#).

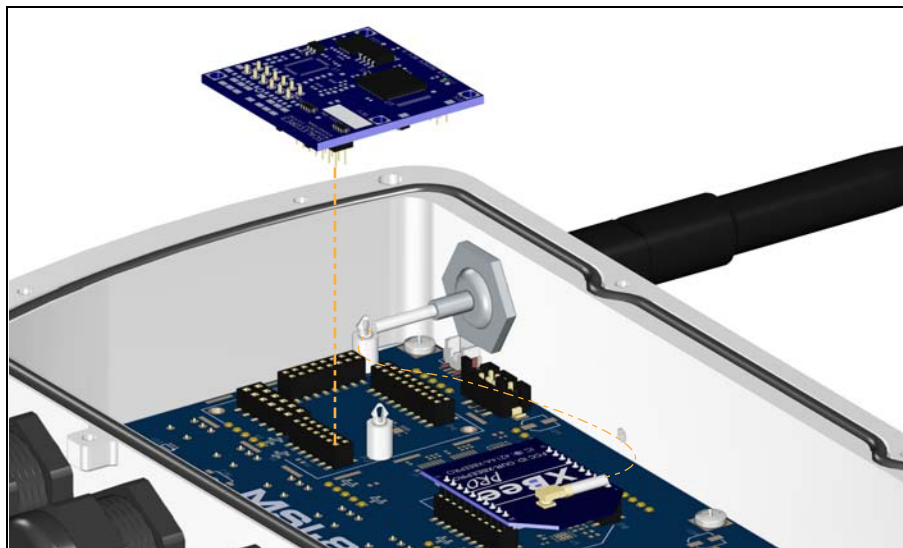

Figure 3-8. ScaleCore Card Location

2. Pull the ScaleCore card up to remove it.
3. Align the new card to the CPU board and standoffs.
4. Press firmly to secure the card in place.

### 3.8 Antenna Replacement

There are many antenna options available with the *MSI-8004HD* ([Section 6.9 on page 46](#)). This section contains instructions to replace the standard antenna. For other options, contact Rice Lake Weighing Systems or a local dealer.

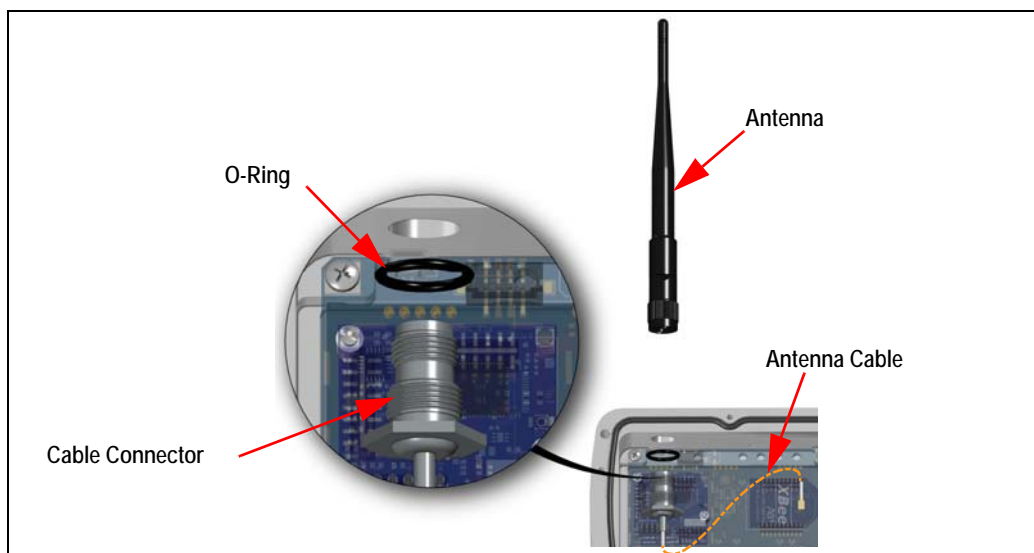

Figure 3-9. Replace Antenna

1. Remove backplate (only if replacing the internal antenna cable). See [Section 3.4 on page 7](#).
2. Unscrew the antenna from the cable connector.
3. If replacing antenna cable, remove the connector and o-ring from the enclosure and disconnect from the Xbee card.
4. Install a new antenna or antenna cable, reverse the above steps.

### 3.9 Tilt Stand



Figure 3-10. Install Tilt Stand

1. Place Locktite<sup>®</sup> on the end of the set screws and screw them into the hole on each side of the indicator.
2. Place a washer over each set screw.
3. Align the stand with the set screws on the indicator.
4. Place the remaining washers on the set screws on each side of the indicator.
5. Screw knobs onto set screws loosely.
6. Adjust tilt of indicator to desired position and tighten knobs.

### 3.10 Battery Option

Battery powered *MSI-8004HD* configurations are available as listed in Table 1-3. The battery powered *MSI-8004HD* is powered by a 5VDC Li-ion rechargeable battery built into the included Tilt Stand Kit.

This battery operates for up to 80 hours (depending on LED brightness setting) before requiring recharging.

Charging time for a completely discharged battery is up to eight hours. A spare battery pack is recommended to keep the *MSI-8004HD* in continuous operation.

#### IMPORTANT

*To obtain maximum service life from the batteries they should be stored between -4°F and 122°F (-20°C and +50°C). Stored batteries should be recharged every three months.*

#### 3.10.1 Battery Life

The battery life of the *MSI-8004HD* depends on a number of factors:

- brightness of the LED display and number of segments lit
- amount of RF activity
- age of the battery
- condition of the SLA battery.

In order to conserve battery life, the *MSI-8004HD* includes the following features.

- Automatic Off Mode — senses no activity after a set amount of minutes and turns the scale off.
- Sleep Mode — dims the display after a set amount of minutes of no scale activity.



The *MSI-8004HD* automatically turns off when the battery is discharged and requires recharging. Li-ion batteries benefit from frequent recharging and can be recharged when there is still available life.

Due to the maintenance discharge imposed on the battery by the *MSI-8004HD* electronics, do not store with the battery in the indicator. Remove the battery if it will not be used for more than two weeks.



**Note** Use the following note for battery charging, storage and disposal:

- \* For continuous indicator use, a fully charged spare battery is recommended
- \* Replace the drained battery as close as possible to the low battery warning
- \* Batteries that have not been deep discharged should withstand 500 to 1500 charging cycles
- \* Low battery warning annunciator indicates two to four hours of use prior to indicator powering off
- \* For long term storage, remove the battery to prevent deep discharge
- \* Recycle battery at an authorized recycling center when the average life drops to 20 hours or less

### 3.10.2 Battery Charger

The battery option is shipped with a charger designed to charge and maintain the battery. Exact charging time will depend on the degree of discharge of the battery. A battery removed when the low battery warning first appears should take about six hours to fully charge.

### 3.10.3 Install Battery Option



Figure 3-11. Tilt Stand with Battery Option

1. Power off the indicator.
2. Remove indicator from the tilt stand by removing the knobs, washers and screws.
3. Install the indicator on the battery option tilt stand. See [Section 3.9 on page 12](#).
4. Remove the USB cable to the battery, if needed
5. Remove the back plate of the indicator. See [Section 3.4 on page 7](#).

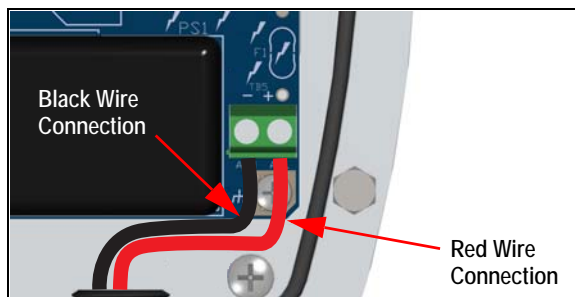

Figure 3-12. USB Cable to CPU Board

6. Connect the USB cable from the battery to the CPU board.

7. Replace the back plate.
8. Plug the USB cable to the battery.
9. Power on the indicator.

### 3.10.4 Replace Battery

1. Power off the indicator.

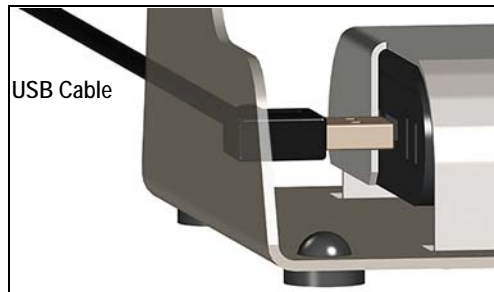

Figure 3-13. Disconnect USB Cable

2. Remove the cable from the USB plug in the battery.
3. Remove indicator from the tilt stand by removing the knobs, washers and screws.

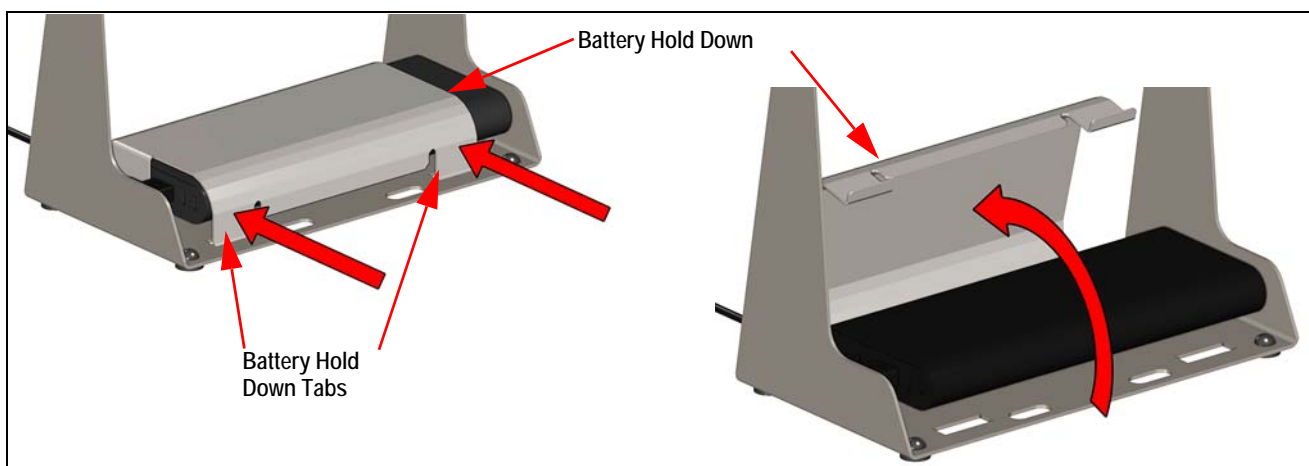

Figure 3-14. Remove Battery Hold Down

4. Press on the battery hold down tabs and push it up to release it from the tilt stand.
5. Remove the battery.
6. Place a charged battery on the tilt stand, ensuring the end with connections is facing the correct direction.
7. Put the tabs from the battery hold down into the slots on one side of the tilt stand and rotate it down over the battery.
8. Press the tabs it and insert into holes in the tilt stand.
9. Reinstall the indicator. See [Section 3.9 on page 12](#).
10. Connect the USB cable to the battery.
11. Power on the indicator.

### 3.11 Parts Illustrations

Refer to the following illustrations and list for replacement parts.

#### 3.11.1 MSI-8004HD Indicator

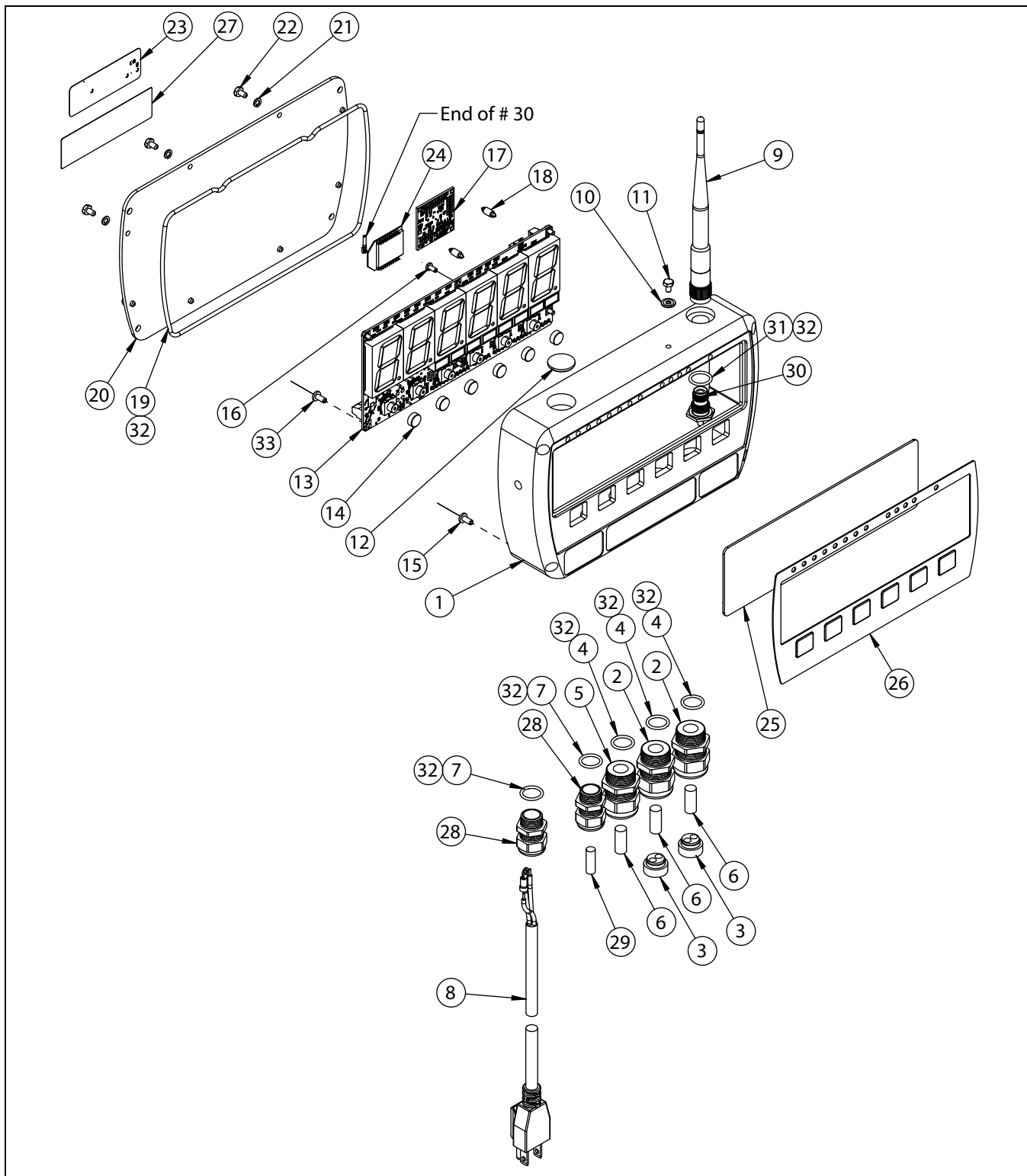

Figure 3-15. MSI-8004HD Parts Illustration

ITEM NO.	Part No.	DESCRIPTION	QTY.
1	176517	Enclosure Machined 8004HD	1
2	177368	Conn, Feed Thru, Liquid, Dome, PG13, GY	2
3	177365	PG13 Insert For Cable Gland, 2 Hole, 5 mm	2
4	177366	O-Ring, PG13, Buna-N, 8004HD	3
5	177364	Conn Feed Thru, Liquid Tight, Dome, PG13, Blk	1
6	142554	Pin Round Acetal 0.312 Ø x 3/4"	3
7	177363	O-Ring, PG9, Buna-N, 8004HD	2
8	See Note*	Power Cord	1
9	143283	Antenna 2.4 GHz	1
10	143272	Washer Seal SS #6	1
11	143271	Screw Mach Hex HD DR HD 6-32 x 1/4" SS	3
12	158438	Plug 0.750 Ø w/ Adhesive	2
13	See Note*	PCA 8004HD Indicator	1
14	177362	Key Cap, SMS Switches	6
15	144537	Screw LKG PCH PH 6-32 x 1/4" SS (AC Only)	1
16	142233	Screw LKG MACH PNH 4-30 x 3/16" SS	5
17	See Note*	PCA Scalecore3 4 Channel	1
18	144929	Spacer Miniature Dual	2
19	153110	O-Ring 7-1/4 x 0.103	1
20	152034	Cover Fixed Mount	1
21	146538	Washer Split Lock SS #6	8
22	146022	Bolt HH 6-32 X 1/4" CAP SS	6
23	148637	Serial Number Tag	1
24	144773	Radio Module XBEE-PRO	1
25	177579	LED Filter Med Grey 8004HD	1
26	178180	Overlay, MSI-8004HD, Std	1
27	159855	Overlay FCC	1
28	141593	Conn Feed Thru Liquid Tight Dome PG9 w/ Nut	1
29	141991	Pin Round Acetal 0.25 Ø	1
30	152051	Cable Assembly RF COAX	1
31	153793	O-Ring 1/2 ID x 0.070	1
32	142039	Silicone Oil 1000 CS	AR
33	146543	Screw PH 4-40 X 1/4" NYLON	1
* Part number varies per configuration			

Table 3-1. MSI-8004HD Parts List



### 3.11.2 Tilt Stand

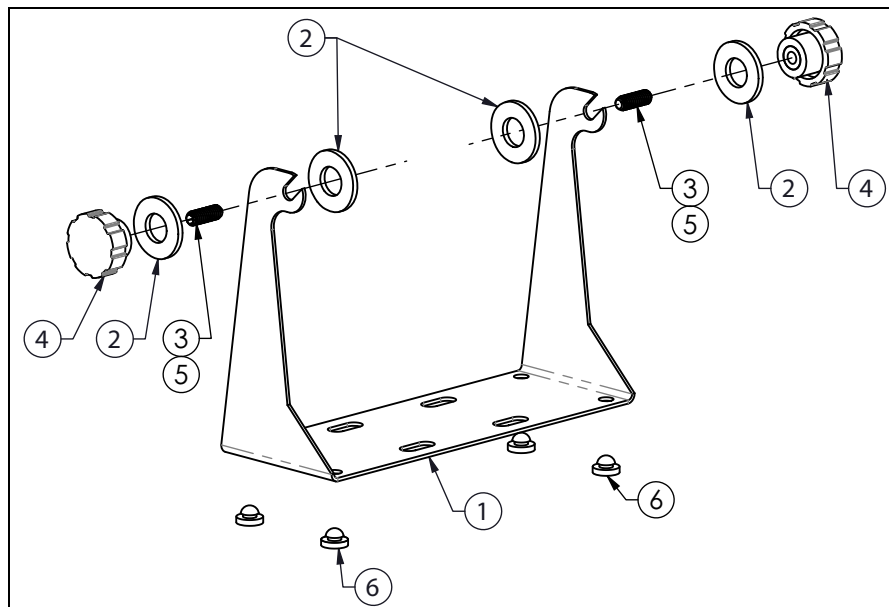

Figure 3-16. Tilt Stand Assembly (155173)

ITEM NO.	Part No.	DESCRIPTION	QTY.
1	155172	Tilt Stand	1
2	146200	Washer Flat 5/8 Plated	4
3	155192	Screw Set Allen DR CP SS 5/16-18 x 7/8 LG	2
4	143879	Knob Fluted 5/16-18 Internal Thread	2
5	142031	Adhesive Loctite® 271-21 Red 0.34 oz	2
6	143224	Rubber Feet	4

Table 3-2. Tilt Stand Parts List

## 3.11.3 Battery Option

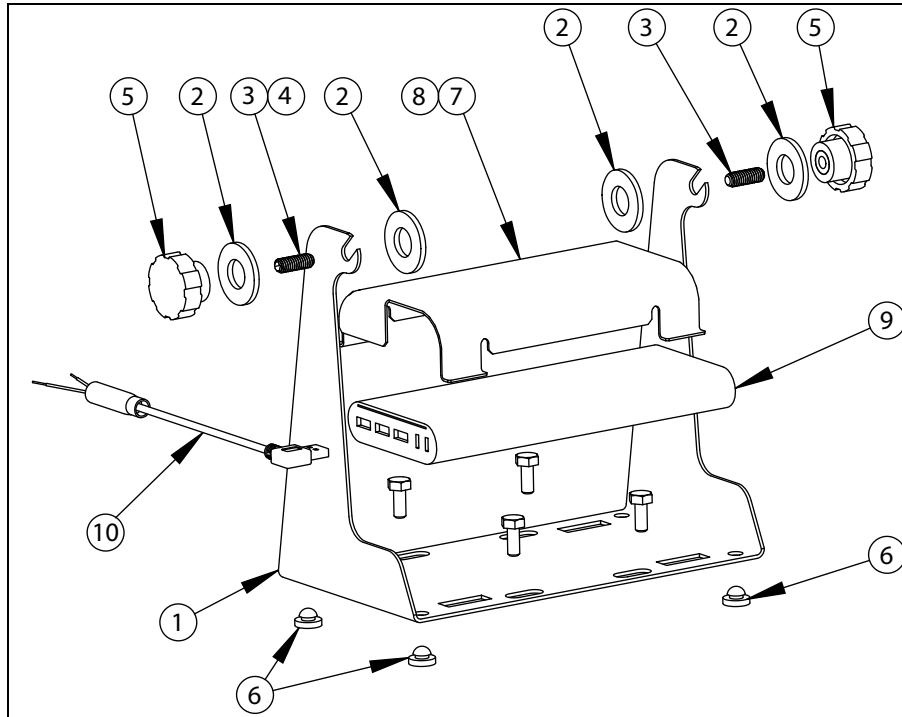











Figure 3-17. Battery Option Parts Illustration

ITEM NO.	Part No.	DESCRIPTION	QTY.
1	155172	Tilt Stand	1
2	146200	Washer Flat 5/8 Plated	4
3	155192	Screw Set Allen DR CP SS 5/16-18 x 7/8 LG	2
4	142031	Adhesive Loctite® 271-21 Red 0.34 oz	AR
5	143879	Knob Fluted 5/16-18 Internal Thread	2
6	143224	Rubber Feet	4
7	183070	Battery Hold Down 8004HD	1
8	148599	Pad Battery Side	4
9	184043	Battery, 5V Li-ion, USB	1
10	183494	Cable Assembly USB Power	1

## 4.0 Setup

The front panel keys function as shown below, when navigating through the menus during setup.

- Press  to enter or select a parameter.
- Press  to scroll through the parameters.
- To enter a decimal point, press  while the digit is blinking.
- Press  to save and go back one level or to weigh mode. *STORE* displays briefly.
- To change an entered value, press  to step back one digit and press  to change the digit.
- Press  to exit without saving changes.
- Press  and  simultaneously to initiate a test of the unit.

### 4.1 Setup Menu

To enter the setup menu, press the  and  keys at the same time.



**Note** *Not all parameters are available when the regulatory setting is HB-44 or R76, see [Section 4.12 on page 29](#).*

Parameters	Choices	Description
FUnc 1 FUnc 2		Function key 1 – Configurable to listed parameters; See <a href="#">Section 4.2 on page 21</a> ; Default OFF
		Function key 2 – Configurable to listed parameters; See <a href="#">Section 4.2 on page 21</a> ; Default OFF
	OFF	No function is assigned; The F-Key is disabled
	TEST	Test – runs an LCD test and displays system information; See <a href="#">Section 4.2.1 on page 21</a>
	TOTAL	Total – accumulates multiple weighments; See <a href="#">Section 4.2.2 on page 22</a>
	VIEW TOTAL	View total – activates the total weight display followed by the number of samples See <a href="#">Section 4.2.2 on page 22</a>
	NET/GROSS	Net/Gross – toggles between Net and Gross modes; See <a href="#">Section 4.2.3 on page 22</a>
	PEAK HOLD	Peak Hold – automatically updates the display when a higher peak weight reading is established See <a href="#">Section 4.2.4 on page 22</a>
	2 UNITS	2 Units – switches the force units between lb and kg; See <a href="#">Section 4.2.5 on page 22</a>
	HI RES	Hi Res – the unit is more sensitive to motion and movement resulting in a less stable display See <a href="#">Section 4.2.6 on page 23</a>
	PRINT	Print – outputs a configured text string to the RS-232 port on the base of the Dyna-Link See <a href="#">Section 4.2.7 on page 23</a>
	TARE	Tare – can be programmed to a F-key if desired, however, the <i>MSI-8004HD</i> has a dedicated tare key so it is not necessary
	CHAN	Chan – displays connected scan channels in order
ADD LOAD	Add Loads – switching display summing methods of local physical load pins (all, pairs or both) See <a href="#">Section 6.1 on page 35</a> .	

Table 4-1. Setup Menu Parameter Descriptions









Parameters	Choices	Description
A-OFF	OFF 15 30 45 60	Auto Off – prolongs the battery life of the scale by turning power off after the set time (in minutes) that the scale is not in use; See <a href="#">Section 4.3 on page 23</a>
SLEEP	OFF 5 15 30	Sleep – time (in minutes) before unit enters the sleep mode See <a href="#">Section 4.4 on page 24</a>
d, SPL	Auto Lo-1 Lo-2 Hi-1 Hi-2	Display Intensity – used to set the display brightness See <a href="#">Section 4.5 on page 24</a>
CoLor	GrEEEn rEd orAnGE bLUe	LED – set the display color to green, red or blue <i>NOTE: when green is selected, if setpoint 1 trips, the display color changes to red and if setpoint 2 trips the display will turn to orange</i>
SEtPoIntS SEtPt 1-8	-- GrERtE LESS OFF	Setpoints can be enabled/disabled only when using the remote display; see <a href="#">Section 4.6 on page 25</a> Greater Than – setpoint triggers when the tension exceeds the value Less Than – setpoint triggers when the tension is less than the value Off - setpoint parameter is disabled
OUtPUt	 LAtch Coil	Relay Output – dependant on the application being used Latch – if power is lost, the relay retains it's settings Coil – needs power to remain position
tOtAL	OFF tEtOn A. LoAd A. LAsT H. HiGH	Total Accumulation - sets the choice for weight accumulation for a single scale See <a href="#">Section 4.2.2 on page 22</a> ; When set to off, it's disabled Total On - Is a manual choice for accumulation; See <a href="#">Section 4.2.2 on page 22</a> . Auto Total - Choices for setting automatic accumulations.
FILtEr	OFF LO H r 1 H r 2	Weight Filter – allows the scale to adjust to situations where there may be movement
UnIt	lb kg Ton Mton kN	Weight Units – toggle units between pounds and kilograms
b.LiFE	StAnd LoNG	Battery Life – sets the options for standard or extended battery life See <a href="#">Section 4.11 on page 29</a>
StAnd	i ndU5 Hb-44 r-76 i unIt	Standards – sets the industry standard to be used <i>Note: When set to HB-44 or R76 the following options are not accessible:</i> bLiE SEtPoIntS OUtPUt b.LiFE

Table 4-1. Setup Menu Parameter Descriptions













Function key setup is independent.



- , ,  and  are preprogrammed to the parameters noted on the key.
-  and  can be programmed to other parameters if desired ([Section 4.2 on page 21](#)).  
If set to *OFF* there is no action when pressed. Keys can be reprogrammed to default selections, if desired.
- If a programmed function key does not work, the connected scale may not be set up to support the key.  
*Example: If the Function key is set for TOTAL, then TOTAL mode setup in the Setup Menu must also be set up for the target scale.*



## 4.2 Function Keys

There are two programmable function keys on the *MSI-8004HD*,  and .

1. Press  and  at the same time, *FUNC 1* displays.
2. Press  to scroll to the function key to be programmed.
3. Press . The currently saved parameter displays.
4. Press  to scroll through the settings.
5. Press  to select the desired setting.
6. Press  to save and exit.

### 4.2.1 Test







   can be pressed simultaneously to run a test of the *MSI-8004HD only*.

 or  can also be set to TEST if desired.

To run a test, press *Fx-TEST*, the following items scroll across the display.

- Illuminates all LED display segments and all LEDs
- *Soft* followed by the version number
- *Stand* followed by the standard setting
- *Batt* followed by the battery level in volts
- *TEST* followed by counting from *0.0.0.0.0.0* to *9.9.9.9.9.9*

The test can be single stepped by:

1. Press    simultaneously (or programmed F-Key), immediately press  to stop the auto scroll.
2. Use  to scroll through the steps and  to view the step value.
3. Press  to abort the test at any time.

Internal tests are also performed; if any test fails, an error code is displayed. See [Section 7.2 on page 49](#) for a description of all error codes.

#### 4.2.2 Total

1. Ensure the total mode has been programmed in the setup menu. If this has not been setup the F-Key assigned to *Total* will not work.
2. Program an F-key to Total. See [Section 4.2 on page 21](#).
3. Press Fx-Total to perform the total function set in [Section 4.8 on page 27](#).



#### Note

*This feature should not be confused with the *ttl.rd* (Total Remote Devices) function, which will add weight from two or more load sensors.*

#### 4.2.3 Net/Gross

Program an F-key to NetGross. See [Section 4.2 on page 21](#).

Press Fx-NetGross to toggle between gross and net (gross minus tare). Fx-NetGross only functions if a tare has been established.

The operator can switch back to gross from net without clearing the tare value. Only clearing or setting a new tare changes the tare value held before switching into Gross mode.

#### 4.2.4 Peak Hold

Peak hold uses a high speed mode of the A/D converter allowing it to capture transient loads at a far higher rate than typical scale.

- Peak Hold is cleared and enabled by pressing Fx-P-HLd.
- When a new peak is detected, the Fx LED will flash three times.
- The accuracy of the system in peak hold is slightly reduced to 0.2 percent of Capacity + 5d.
- The filter setting is turned off while in peak hold mode to obtain the fastest acquisition rate.

#### Example

*The Peak Hold function is useful in Dynamic and Fall tests. Common tests include Overall Breaking Strain (OBE), Breaking Force, and Cycled Breaking Strain.*

Capture Peak Force:

1. Program an F-key to P-HLd. See [Section 4.2 on page 21](#).
2. Prepare the stand test and test sample.
3. Press .
4. Press Fx-P-HLd, confirm that Pk is illuminated on the display.



#### Note

*A small jump in the reading may occur depending on the stability of the test device.*

5. Apply the test weight. The Fx LED blinks three times when a new peak ID is detected
6. Remove the weight and the peak value is recorded.
7. To run a new test, press Fx-P-HLd to clear the peak value. Repeat steps 3 to 6.

#### 4.2.5 Units



is preprogrammed to Units. To use as units, do not program to a different parameter.

Press  to set the units required for display.



### 4.2.6 Hi-Res

Program an F-key to HiRes. See [Section 4.2 on page 21](#).

Pressing Fx-HiRes places the display into a temporary high resolution mode. This mode continues until Fx-HiRes is pressed again, or power is cycled.



*Hi-Res mode does not increase the accuracy, but allows for smaller weight incrementation to display.*

Use  or  to zero out any initial error.

### 4.2.7 Print







The *Print* function is set to , so there is no need to program F1 or F2 to print.

## 4.3 Auto-Off

The Auto-Off feature powers off the unit when not in use. The time limit is reset when a button is pressed or the detected load is in motion exceeding 10 d. Using the battery option will save battery life.

When disabled, the unit only turns off by pressing , or if the battery dies.

To set the *Auto-Off* function:







1. Press and hold  and . *FUNC 1* displays.
2. Press  to scroll to *A-OFF*.
3. Press . The current auto off time displays.
4. Press  to scroll through the available times.
5. Press  when the desired time is displayed. *SLEEP* displays.
6. Press  to exit setup and store the settings.

## 4.4 Sleep

The Sleep parameter reduces power consumption by automatically dimming the display during periods of inactivity. To wake the unit, either a button must be pressed (front panel or RF remote), the weight must change by the amount set for Auto-Off (d) or there is a motion event.



**Note** *Sleep must be set to less time than the Auto-Off timer.*





1. Press and hold  and . *Func 1* displays.
2. Press  to scroll to the *SLEEP* function.
3. Press . The current *SLEEP* time is displayed.
4. Press  to scroll through the available times.
5. Press  when the desired time is displayed.
6. Press  to exit setup and store the settings.

## 4.5 Display Brightness

The Display setup menu is used to set the display brightness. There are four fixed brightness settings and one automatic light-sensing brightness setting.



The Auto setting automatically detects the ambient light and adjusts the brightness of the display accordingly. Bright light causes the display to be at the brightest setting. The display brightness reduces as ambient light reduces.

There are four fixed brightness settings, LO-1, LO-2, HI-1 and HI-2. Lower brightness settings increase battery life.

1. Press and hold  and . *Func 1* displays.
2. Press  to scroll to the *Display*.
3. Press . The current setting is displayed.
4. Press  to scroll through the available settings.



**Note** *The display brightness changes as each setting is displayed.*

5. Press  when the desired setting is displayed. *5.000* displays.
6. Press  to exit setup and store the settings.



## 4.6 Setpoints

*MSI-8004HD* display setpoints can be configured from remote devices or local math channel. If setpoint source is configured from remote devices, then setpoint event will be logical or with other remote device's setpoint event.

The *MSI-8004HD* supports eight LEDs for triggered setpoints. Common uses of setpoints are for warnings or process control. The *MSI-8004HD* has an audible output option that is triggered by Setpoint 1. Contact Rice Lake Weighing Systems for other setpoint output options.

Setpoint	Description
<b>Setpoint Mode</b>	
OFF	Setpoint is not activated
GRERt	Indicates the setpoint will trigger when the weight exceeds a set value
LESS	Indicates the setpoint will trigger when the weight is less than a set value
<b>Setpoint Weight Type</b>	
NETGr	responds to net or gross weight
GROSS	responds to gross weight regardless of the display
TOTAL	responds to the totaled weight
T-Cnt	responds to the total count (number of samples)
LFcnt	responds to the number of times the weight has exceeded 25% of capacity

Table 4-2. Available Setpoint Settings

When the display color is set to green, the *MSI-8004HD* is set to change the color of the display when setpoints 1 and 2 are tripped. This is useful in warning of possible overload conditions. This feature is not available with the blue LED display or when the display color is set to orange or red.









To set the display color to green and not have it change when setpoints are tripped, only use setpoints three through eight. The color of the display is based upon which setpoints are tripped. It can be used for any type of setpoint.







Setpoint 1	Setpoint 2	Display Color
Not tripped	Not tripped	Green
Not tripped	Tripped	Orange
Tripped	X	Red

Table 4-3. Display Colors- Green Only



Whenever Setpoint 1 is tripped, the display will turn red, regardless of the state of setpoint 2.

To set the setpoint:

1. Press and hold  and . *Func 1* displays.
2. Press  to scroll to the desired setpoint (*SetPt 1 - 8*).
3. Press . The current setpoint mode is displayed.
4. Press  to scroll to the setpoint mode desired.
5. Press . The current setpoint weight type is displayed.
6. Press  to scroll to the desired weight type.
7. Press . The desired weight type continues to display.

8. Press .  $5n\ 1 - 4$  displays ( $5n\ 1 - 4$  indicates setpoint source is from remote devices).
9. Press  to toggle between  $5n\ 1 - 4$  and  $5n\ 5$  ( $5n\ 5$  indicates setpoint source is the local math channel).
10. With the desired setting displayed, press . The current weight type value is displayed.
11. Press  to scroll the numbers and  to enter each digit.
12. When the correct value is displayed, press . The next setup menu item is displays.



**Note** To enter a decimal point, press  while digit is blinking. To correct a digit, press  to step back.

13. Press  to exit setup and store the settings.





## 4.7 Output

Relay output allows the selection of Latch or Coil relays.

- Latch relays retain position even if the power fails,
- Coil relays reset when power fails.



### IMPORTANT

*In the event of a power failure, the Latch relay uses continuous battery power and will deplete the battery more quickly than the coil relay.*

1. Press and hold  and .  $Func\ 1$  displays.
2. Press  to scroll to  $OutPut$ .
3. Press . The current setting is displayed.
4. Press  to toggle between  $Coil$  and  $Latch$ .



**Note** The display brightness changes as each setting is displayed.

5. Press  when the desired setting is displayed.  $b. L\ FE$  displays.
6. Press  to exit setup and store the settings.



## 4.8 Total Mode

For the accumulation of multiple weighments, the Total function uses the displayed load, so gross and net readings can be added into the same total.

There are four modes of totalizing, a manual and three auto modes.



All modes require that the weight on the scale return below 0.5% (relative to full scale) of *Gross Zero* or *Net Zero* before the next weighment can be added. Applied weight must be  $\geq 1\%$  of full scale above *Gross Zero* or *Net Zero* before it can be totaled.

### Manual Total

Manual Total (ttlOn) adds a current weight to a previously accumulated value manually. To add weight to the total it must be greater than 1% of capacity and not yet totaled. This assures that a weight on the scale is only added to the total once.

1. Program a F-key to Total. See [Section 4.2 on page 21](#).
2. With the weight to be added on the scale, press F-Total. The acknowledge LED blinks to indicate the weight was accepted and the *TOTAL* annunciator lights. Then the total weight is displayed for five seconds and the number of samples is displayed for two seconds.
3. Repeat steps 1 & 2 until all weight samples have been added.



*Total Mode will not function while the scale is in motion, ensure   is on. If the system fails to achieve stable readings, increase the filter setting or increase the size of the scale division (d) in the Init Cal procedure.*

*The F-Total functions as View Total only until the 1% threshold is exceeded to allow the addition to the total value.*

### Auto Total







This mode has three variations which are programmed in the Setup menu.

Program an F-key to *AUTO TOTAL*, it functions as *Auto Total On* / *Auto Total Off*. See [Section 4.2 on page 21](#).

Setpoint	Description
R. LoAd	Auto Load – ensures any settled load above the Rise Above threshold will be automatically totaled. The scale must fall below the Drop Below threshold before the next total is allowed.
R. LAsT	Auto Last – takes the last settled weight to auto total with. The total occurs only once the scale goes below the threshold. This allows the load to be adjusted without a total occurring. Once the load is removed, the scale uses the last settled reading for total.
R. h i Gh	Auto High – uses the highest settled reading. This is useful for loads that can't be removed all at once.

Table 4-4. Auto Load Selections

### Set Total Mode

1. Press  and  simultaneously. *FUNC 1* will display.
2. Press  to scroll to total.
3. Press . The currently saved total mode is displayed.
4. Press  to scroll through the choices.
5. With choice displayed, press  to select. *F i L t r* will be displayed.
6. Press  to exit setup and store the settings.

### Reset Total Load

To reset the total load to zero, press Fx-Total again and while the total load is being displayed, quickly press .







## 4.9 Filter

The Filter settings are used to stabilize the weight in an unstable condition. Increasing the filter will improve the stability, however settling times will be longer. The *MSI-8000HD* employs algorithms that speed up large weight changes while still controlling vibration even with high filter settings.







Parameter	Description
OFF	Disables filtering function
Lo	Low Filter
Hi - 1	High Filter
Hi - 2	Very High Filter

Table 4-5. Filter Parameters

Use the following steps to set up filtering.

1. Press  and  simultaneously. *Func 1* displays.
2. Press  to scroll to *F i L t E r*.
3. Press . The currently saved filter value displays.
4. Press  to scroll through the values.
5. With choice displayed, press  to select. *un i t* displays.
6. Press  to save and exit to weighing mode.

## 4.10 Unit

1. Press  and  simultaneously. *Func 1* displays.
2. Press  to scroll to *un i t*.
3. Press . *un i t* displays with lb or kg in the lower right of the display area.
4. Press  to toggle between lb and kg.
5. With the desired choice displayed, press  to select.
6. Press  to save and exit to weighing mode.









## 4.11 Battery Life – Optional

Select either Standard (*StAnd*) or Long (*Long*).

In *Long* battery life mode, the system is placed into a sleep state for several seconds at a time if there is no change in tension. This disables the display in order to reduce power consumption and increase battery life. After several seconds, the *MSI-8004HD* will wake up to check for any changes in tension. If there is a change in tension, the unit stays awake. The unit also stays awake if it is in configuration mode.

Although long battery life mode can significantly increase battery life, performance is better in standard battery life mode.

1. Press  and  simultaneously. *Func 1* displays.
2. Press  to scroll to *b. L i FE*.
3. Press . The current battery life setting displays.
4. Press  to toggle between settings.
5. With desired setting displayed, press  to select. *StAnd* displays.
6. Press  to save and exit to weighing mode.

## 4.12 Standard Settings

Setting the Standard to *hb-44* or *r-76* will disable the setup menu after power is cycled. To change this setting, the CAL button must be pressed. It is important that all settings have been configured, including power savings, display color, brightness, and setpoints prior to setting the standard.







### IMPORTANT

*To press the Cal button, the seal must be broken. This removes the Legal for Trade setting and must be resealed by a qualified technician to continue as a Legal for Trade unit.*

Selection	Description
Industrial ( <i>Indus</i> )	With the Industrial standard, there is full range zero, access to units switching, filters and peak hold; Most common setting
Handbook 44 ( <i>Hb-44</i> )	Enables only approved features per the NTEP HB-44 rules and regulations. Access is denied to Peak Hold, and the zero range may be limited. The Filter menu is moved to the calibration setup menu, so filters are only accessible through the calibration seal
R-76 ( <i>r-76</i> )	Sets the scale to enable only approved features per OIML R-76. Only kg weight units are available. The zero range is limited to 4% (-1 to +3% relative to calibrate zero). Net/Gross function is temporary. Once net weight is established, pushing an F key set for Net/Gross will cause a maximum 5 second display of the gross weight. Clear the Tare to display gross weight constantly. Other metrological aspects are changed to meet R-76 requirements.
1Unit ( <i>Unit</i> )	The 1unit standard is the same as Industrial, except units switching is inhibited. Used for metric only countries or where 1unit standard is to allow the scale to be calibrated in units other than lb or kg, since conversions are eliminated. Contact Rice Lake for more information on the standards settings.

Table 4-6. Standard Menu Selections

Use the following steps to set up standard settings.

1. Press  and  simultaneously. *Func 1* displays.
2. Press  to scroll to *StAnd*.
3. Press . The current standard displays.
4. Press  to scroll through the settings.
5. With desired setting displayed, press  to select. *Func 1* displays.
6. Press  to save and exit to weighing mode.

## 5.0 Calibration

The *MSI-8004HD* is calibrated using standard precision test weights. It is required that the weight used is at least 10% of full capacity in order to achieve rated accuracy.

*Example:*

*Use at least a 500 kg test weight to calibrate a 5000 kg capacity unit. The MSI-8004HD RF Indicator supports load pin linearization with up to four span points that can be calibrated in any order. Usually only one cal span point is necessary and is sufficient to reach rated accuracy.*

When adequate test weights are not available, the *MSI-8004HD* can be calibrated using a constant calibration (C- $\bar{C}RL$ ) See [Section 5.3.2 on page 32](#).

### 5.1 Calibration Switch

To calibrate the *MSI-8004HD* indicator it must be put into the calibration mode. The *MSI-8004HD* will need to be resealed after calibration is complete, to be in compliance with NTEP.



Figure 5-1. Calibration Switch



1. Remove screw and washer from the top of the unit.
2. Insert a small non-conductive tool into the hole far enough to press the switch.  $\bar{C}RL$  is displayed.

#### IMPORTANT

Caution should be used when pressing the configuration switch to avoid damage to the switch and other board components.

### 5.2 Reset the Load Pin Calibration

To remove current calibration, a calibration reset must be performed.

1. Select the load pin to reset by pressing the F-Key that is programmed to  $\bar{C}hRn$ .
2. Press the calibration switch and  simultaneously.  $\bar{R}ESE\bar{T}$  flashes.
3. Press .  $\bar{S}UR\bar{E}$  flashes.
4. Press  to reset the calibration for current load pin.  $\bar{C}RL$  displays.
5. Proceed with the Initial Calibration. See [Section 5.3](#).















#### IMPORTANT

Pressing  resets all indicator settings to the original factory settings.

Pressing  to cancel reset and return to the previous menu.



## 5.3 Initial Calibration













Initial calibration is used to setup units, capacity and resolution (d) required for the load pin or after a calibration reset.

1. Press the calibration switch. See [Section 5.1 on page 30](#).
2. Press  to select the load pin to be calibrated.
3. Press  and  simultaneously.  $\bar{C}RL$  displays.
4. Press .  $UNIT$  displays.
5. Press . The default units display.
6. Press  to scroll through the available units.
7. With desired unit displayed, press  to select.  $\bar{C}RP$  is displayed.
8. Press . The default capacity is displayed.
9. To enter a different capacity, press .
10. Press  to scroll through numbers and  to save the selected number and move to next digit.
11. When correct capacity is displayed, press  to store the value.  $d$  displays.
12. Press . The default display divisions are displayed.
13. Press  to scroll through the available display divisions.
14. With desired display division displayed, press  to select.  $UNLd$  displays.
15. Proceed with the routine calibration, starting with [Step 2 of Section 5.3.1 on page 31](#).

### 5.3.1 Routine Calibration

For maintenance and routine calibration use the following steps.

1. Press the calibration switch. See [Section 5.1 on page 30](#).
2. Press .  $UNLd$  displays.
3. Remove all weight from the scale.
4. Press .  $\square$  flashes.
5. Press .  $PASS$  displays momentarily, then  $LOAD$  displays.
6. Load the scale with a precision test weight; for best accuracy a test weight of 10% of capacity or more is recommended.





7. Press . Capacity of the scale flashes.
8. To enter a test weight other than the capacity, press .
9. Press  to scroll through numbers and  to save the selected number and move to next digit.
10. When the correct weight is displayed, press  to store the value. If *Cal* value is within limits, *PASS* displays momentarily, then *LOAD* displays.
11. Press  to enter the second load.
12. Add load to scale and press .
13. Press . The current weight on the scale flashes.
14. Repeat [Step 3](#) through [Step 10](#) for up to four loads.
15. When all loads are complete, press  to store the calibrations. *CAL* displays.
16. Press  to view the cal number. *C-CAL* flashes momentarily followed by the value. Record the *C-CAL* value, it is required when performing a *C-CAL* calibration. See [Section 5.3.2 on page 32](#).
17. Press . *STORE* displays momentarily, then *SETUP* displays.
18. Press  to exit calibration. *STORE* displays momentarily, then the unit returns to weigh mode.

Repeat this procedure to calibrate all scales that are connected to the *MSI-8004HD* remote display.







### 5.3.2 C-Cal Calibration

When adequate test weights are not available, the scale can be calibrated using a cal number calibration which is referred to as C-CAL. To use C-CAL, a factory generated C-CAL value must be known. Rice Lake supplies replacement load pins with the C-CAL value stamped on the serial number label. When a calibration is performed with test weights, a new C-CAL is generated.

The C-CAL number must be known prior to starting this procedure. Rice Lake prints this number on the serial number label. C-CAL reduces slightly the accuracy of the system and is intended for non-critical use only. For highest accuracy, calibrate with precision test weights.













1. Press the calibration switch. See [Section 5.1 on page 30](#).  
When doing the initial calibration option, units and capacity must be set. See [Section 5.3 on page 31](#).
2. Press  to scroll to *C-CAL*.
3. Press . *UNLD* displays.
4. Remove all weight from the scale.
5. Press . *0* flashes and *PASS* will display momentarily. Then *C-CAL* is displayed.
6. Press . The last known *C-CAL* value is displayed.



7. To accept the number displayed, press  and skip to [Step 10](#).  
To enter a different  $C - CRL$  value continue with next step.
8. Press  to scroll through numbers and  to save the selected number and move to next digit.
9. When the correct  $C - CRL$  value is displayed, press  to store. *PASS* displays followed by  $CRL'$  d.
10. Press . *StorE* displays momentarily, then *SEtUP* displays.
11. Press  to exit calibration. *StorE* displays momentarily, then the unit returns to weigh mode.

## 5.4 Setup

Setup is used to set the desired Industry Standard and Auto Zero Maintenance (AZM).

1. Press the calibration switch. See [Section 5.1 on page 30](#).
2. Press  to scroll to *SEtUP*.
3. Press . *StAnd* displays.
4. Press . The current standard setting displays.
5. Press  to scroll to *AutO*. See [Section 5.4.1](#).
6. Press  to enter Auto Zero Maintenance.
7. Press  to toggle between *On* OFF.
8. Press  to set on or off. *O. P-UP* displays.
9. Press  to enter zero on power-up.
10. Press  to toggle between *On* OFF.
11. Press  to set on or off. *StAnd* displays.
12. Press  to return to  $CRL$ .
13. Press  again to exit calibration. *StorE* displays momentarily and the unit returns to weigh mode.

### 5.4.1 Standard Settings

Below are the four selections in the standards menu.



Standard Type	Description
Industrial Industrial	With the Industrial standard, there is full range zero, access to units switching, filters, and peak hold
Handbook 44 HB44	Sets the scale to enable only approved features per the NTEP HB-44 rules and regulations; access is denied to Peak Hold and the zero range may be limited. The filter menu is moved to the cal setup menu, so filters are only accessible by breaking the calibration seal
R-76 R-76	Sets the scale to enable only approved features per OIML R-76 <ul style="list-style-type: none"> <li>only kg units are available</li> <li>zero range is limited to 5% (-2 + 3% relative to calibrate zero)</li> <li>net/gross function is temporary</li> <li>once net weight is established, press an F-key, set to net/gross to display the gross weight momentarily</li> <li>to display only gross weight clear the tare</li> <li>other meteorological aspects are changed to meet R-76 requirements.</li> </ul>
One Unit One Unit	The one unit standard is the same as Industrial, except that unit switching is inhibited, which is useful for metric only countries; allows the scale to be calibrated in units other than lb or kg, since conversions are eliminated.

Table 5-1. Standard Settings Parameter

Contact Rice Lake Weighing Systems for more information on the standards settings.

## 5.5 Reset the Load Pin Calibration

To remove current calibration, a calibration reset must be performed.

1. Press the *F*-Key set to scan to scroll to load pin to reset.
2. Press the calibration switch and  simultaneously. *RESET* flashes.
3. Press . *SURE* flashes.
4. Press  to reset the calibration for current load pin. *LR* displays.
5. Proceed with the Initial Calibration. See [Section 5.3](#).

#### IMPORTANT

Pressing  resets all indicator settings to the original factory settings.

Press the  to cancel reset and return to the previous menu.



## 6.0 Communications Setup

The *MSI-8004HD* uses 802.15.4 transceivers to communicate which operates in the 2.4 GHz systems if:

- Antennas are isolated at least 10' (3 m) from the equipment.
- *MSI-8004HD* based RF systems are peer to peer. In multiple scale connections, it acts as the network coordinator.

The *MSI-8004HD* uses three numbers to establish a piconet. A piconet is a network that is created using a wireless Bluetooth connection. [Table 6-1](#) lists out the three elements used in setting up a piconet.

Name	Description	Recommended Number Range
ScaleCore ID	Used to identify each device in a piconet, its range is 0-254 and cannot be duplicated within the same RF channel	20-30
RF Channel	Establishes the base network that all interconnected devices must match	12-23
Network ID	A 64 bit number that all interconnected devices must match, do not use a small number to avoid other 802.15.4 transceivers that default to a network ID of 0	Maximum of six digits with a range of 0-65535

*NOTE: For all devices that interconnect, the RF channel and network ID must match. The ScaleCore ID must be unique. The Dyna-Link or crane scale that is the weight source should be set to a ScaleCore ID of 0. If other source devices are added, they can be added in sequence.*

Table 6-1. Piconet Setup Ranges

### 6.1 Communications Menu

To enter the Communications menu, press  and  at the same time. *bU5Y* flashes momentarily before entering the communications menu.printer setup

Parameters	Settings	Description
<i>Pr i nt</i>	--	Print – prints a ticket if connected to a printer; see <a href="#">Table 6-3 on page 35</a>
<i>rF</i>	--	Radio Frequency – see <a href="#">Table 6-8 on page 38</a>
<i>Add i ng</i>	tMo.Ld	Load Totaling – The total number of Remote Sensor Devices (RD's) – Range 1-4 (Default is 1)
	ttl.rd	Methods of summing load pins All – total load pins (1-4) Prirs – sum in pairs (requires four remotes) see <a href="#">Section 6.3.1 on page 41</a> both – sum in pairs plus grand total vsedef – programmed using a computer program such as ScaleCore Connect off – summing is disabled
<i>ScALeS</i>	Listid	–
	Scid	ScaleCore ID – number must match
	Sn.id	Sensor ID

Table 6-2. Communications Menu Parameters

The RS-232 communications port is capable of outputting load data. All RF linked device weight modes are available in user formatted form. The control mode directs the *MSI-8004HD* to print. See [Section 6.1.1](#).

The communications port settings are independent of print settings in connected scales. They are only in the *MSI-8004HD*.

Settings	Description
<i>L i StEr</i>	Print setup – select the channel the port will be used with. Options: 0, 1, 2
<i>OutPUt</i>	Port selection – Select the port to use for communication with the printer; Options <i>Port 0</i> , <i>rF</i> , <i>Port 2</i>
<i>StErnG</i>	String Setup – print string format number entry screen. See <a href="#">Table 6-7</a>
<i>EntErL</i>	Print Control Options: <i>uSEr</i> , <i>LoAd</i> , <i>Cont</i> , <i>OFF</i> See <a href="#">Table 6-4</a>
<i>rALe</i>	Output Rate – print string output rate number entry screen. (0-65535 seconds)

Table 6-3. Print Setup Parameters

### 6.1.1 Control Modes

The user can select four control modes. They are described in [Table 6-4](#).

Mode	Description
uSEr	Printing is controlled by pressing F-3 Print
LoAd	One print occurs when a stable load is read, the scale must return to near zero before another print occurs <i>NOTE: Other configurations of load are available using the ScaleCore Connect. It can be downloaded from the Rice Lake Website</i>
Conti nuous	The unit will continuously output the data at a rate specified in the rate parameter (up to 65,535 seconds); setting the interval to 0 will set an interval as fast as the system can go
OFF	Printing is disabled; power consumption is lower with the print off

Table 6-4. Control Modes

### 6.1.2 Standard Print Strings

Commands that can be used to format gross, net and print strings are shown below.

Command	Description
<T>	Load data
<U>	Units
<M>	Load mode (lb/kg)
<CRLF>	Carriage return line feed
<SP>	Space

Table 6-5. Standard Print Strings

1	Current load	Fixed output length: 16. Leading zeros suppressed except for the least significant digit (LSD). <TTTTTT><SP><UU><SP><MMMM><CRLF>
2	Net load	Fixed output length: 16. Leading zeros suppressed except for the LSD. <TTTTTT><SP><UU><SP>NET<SP><SP><CRLF>
3	Gross load	Fixed output length: 16. Leading zeros suppressed except for the LSD. <TTTTTT><SP><UU><SP>GROSS<CRLF>
4	Tare Weight	Fixed output length: 16. Leading zeros suppressed except for the LSD. <TTTTTT><SP><UU><SP>TARE<CRLF>
5	Total Weight	Fixed output length: 16. Leading zeros suppressed except for the LSD. <TTTTTT><SP><UU><SP>TTL<CRLF>
6	Number of Samples Totaled	Fixed output length: 16. Leading zeros suppressed except for the LSD. <SP><SP><SP><SP><SP><SP><SSSSSS><SP><T-CNT><SP><CRLF>
7	Current Weight Mode	Net, Gross, Peak, etc <SP><MMMM><CRLF>
8/9	Carriage Return/ Line Feed	Used to add a space between print records. <CRLF>

Table 6-6. Standard Print Strings

Combinations of the standard print strings can be entered in the string number entry screen.

*Example: To get a Net, Gross, Tare printout with a space between records, enter 2349.*





## Print Strings Formats

String No.	Format	Prints
1	Wt-Unit-Mode ↵	Current weight
2	Wt-Unit-Net ↵	Net weight
3	Wt-Unit-Grs ↵	Gross weight
4	Wt-Unit-Tare ↵	Tare weight
5	Wt-Unit-Total ↵	Total weight
6	#Samples-TCNT ↵	Total count
7	no units or mode ↵	Current weight
8	—	Reserved
9	↵	CR-LF







Table 6-7. Print Strings Formats

The *ScaleCore Connect* application can also be used for custom output strings and can be downloaded from the Rice Lake website.

The serial output is configured as 38400 baud, Xon/Xoff handshaking, no hardware handshaking, 1 stop bit, no parity. Other baud rates are possible by special order only.





### 6.1.3 Printer Output Setup

Use the following steps to set up the printer output.

1. Press  and  at the same time. *Print* displays.
2. Press . *Unit* displays.
3. Press  to scroll to *Unit*.
4. Press . The current print string number is blinking.
5. Press  to scroll through the numbers and press  to save number and move to the next digit.

*Example:*

*If Net, Gross and Tare are to be used for the print format, the entry required is 2349. The 2 is net, 3 is Gross, 4 is tare and 9 inserts a space before the next print output.*











6. Once value is set, press  to save the print mode. *Unit* displays.
7. Press . The current control mode displays.
8. Press  to scroll through the options.
9. When the desired control mode is displayed, press . *Unit* displays.



**Note** If control mode has been set to continuous, press  then proceed to [Step 13](#).

10. Press . The current print rate displays.



11. Press  to scroll through the numbers and press  to save number and move to the next digit.
12. When value is correct, press . *LISTNR* displays.
13. Press . The current listener value displays.
14. Press  to scroll through the numbers and press  to save number and move to the next digit.
15. Once the desired value is displayed, press  to save. *OUTPUT* displays.
16. Press . The current output displays.
17. Press  to scroll through the options.
18. Once the desired output is displayed, press  to save. *SEND* displays.
19. Press  three times to exit, *STORE* displays briefly, then the unit returns to weigh mode.

## 6.2 RF Setup

The *MSI-8004HD* allows the use of dual RF modems. In addition to the XBee modem other options include:

- FHSS
- Wi-Fi
- Bluetooth
- Other

Contact Rice Lake Weighing Systems or a local dealer for more information about these options.

Mode	Description
<i>On. OFF</i>	Enable RF – On/Off, affects continuous mode only.
<i>Scale ID</i>	ScaleCore ID – range 1-254, (20-30)
<i>ChanL</i>	RF Channel – Range 12-23 <i>NOTE: The RF communication channel is not the same as the scan channel and is not preprogrammed to the F2 key</i>
<i>net ID</i>	Network ID – Range 0-65535
<i>STREN</i>	Transmission Strength – Range 0-4; see <a href="#">Table 6-9 on page 40</a>
<i>TYPE</i>	Select radio card that is being used; select <i>ZBEE</i> when the XBee card is installed; for all other cards, use <i>OTHER</i>
<i>Hold</i>	When set to <i>On</i> , the radio continues to use power. This will use the battery power faster. Default is set to <i>OFF</i> .

Table 6-8. RF Setup Parameters – XBee Modem Only













*It is possible to have multiple separate MSI ScaleCore RF networks in the same location. Each device on the same network must be on the same channel.*

*For best performance, different ScaleCore networks should be on different RF channels*















Use the following steps to set up the RF menu parameters.

1. Press  and  simultaneously. *Prnt* displays.
2. Use the  to scroll to *RF*.
3. Press . *On. Off* displays.
4. Press . The currently saved parameter is displayed.
5. Press  to toggle between On and Off.
6. With On displayed, press  to select. Off is only used when the *MSI-8004HD* is not using its RF Modem(s) for communication.
7. Press . The current ScaleCore ID displays.
8. Press  to scroll through numbers and  to save number and move to next digit.
9. When value is correct, press  to store. *ChanL* displays.
10. Press . The current channel setting displays.
11. Press  to scroll through numbers and  to save number and move to next digit.
12. When value is correct, press  to store. *Net ID* displays.
13. Press . The current Network ID displays.
14. Press  to scroll through numbers and  to save number and move to next digit.



*Rice Lake Weighing Systems recommends at least a four digit for the Network ID, to ensure there are no conflicts with any other 802.15.4 networks.*

15. When value is correct, press  to store. *StrEn* displays.
16. Press . The current strength setting displays.
17. Press  to scroll through 0-4.
18. When the number is correct, press . *Type* is displayed.
19. Press . The current type displays.
20. Press  to scroll through values.
21. With selected value displayed, press . *Hold* displays.
22. Press . The current setting displays.

23. Press  to toggle between on and off.
24. When the selection is correct, press  to store. *On. OFF* displays.
25. Press  to save and exit the RF menu.
26. Press  to exit to the communication menu.



*Transmission strength should be set to the lowest setting possible to achieve the transmission required. Both the scale and the MSI-8004HD should be set to the same transmission strength.*

Setting	RF Power Level	Transmit Current	Note
0	10dBm	137mA	Lowest Transmission Power
1	12dBm	155mA	(default on 7300s and 8000s)
2	14dBm	170mA	—
3	16dBm	188mA	—
4	18dBm	215mA	—

Table 6-9. Transmission Strength Setting – XBee Modem Only

### 6.3 Setup Multiple Sensor Network

The *MSI-8004HD* can monitor up to four load pins. They can be read individually, in pairs or summed. Load pin is shown for illustration purposes only, others can also be used.

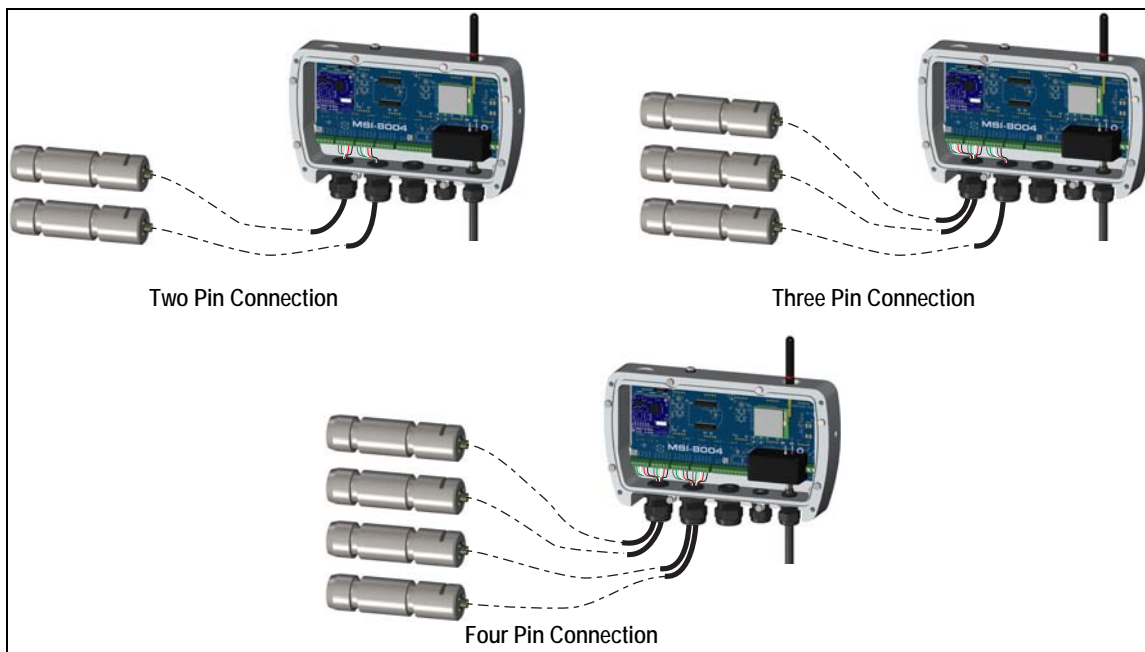













Figure 6-1. Multiple Sensor Network

Each load pin has a unique ScaleCore ID (SCID). The IDs must be consecutive, starting with 0.



### Set the Total Number of Load Pins

1. Press  and  at the same time. *Pr i n t* is displayed.
2. Press  to scroll to *Add i n g*.
3. Press  *t n o. L d* is displayed.
4. Set the number of load cells attached (2-4) by pressing  to scroll through the numbers and press  to save and move to the next number.
5. With correct number of load pins displayed press . See [Section 4.8 on page 27](#). This number does not include the *MSI-8004HD* or any modems. *Add. L d* displays.
6. Press . The current summing mode displays
7. Press  to scroll to the desired summing mode
8. Press . *t n o. L d* displays.
9. Press  twice to exit to the weigh mode.

#### 6.3.1 Load Totaling Settings

The four different types of load totaling modes are explained below.

##### All

All channels are added together. Press *Fx-Add.Ld* to view the sum of all sensors connected. Press *Fx-Add.Ld* again. *Add. L d* (Add Loads) displays to confirm that the summed channels are being displayed.



*If only the sum is to be observed, disable the Chan function key using the function key setup menu ([Section 4.2 on page 21](#)).*

##### Pairs

Pairs is used with four sensor systems, scrolling through the channels with *Fx-Add. L d*, they will be presented as separate weights first and then as pairs. This display is preceded by the LCD message *Pr i r 1* and *Pr i r 2*.

##### Both

This mode displays both the pair totals and the overall total. Each press of *Fx-Add. L d* scrolls through the summed combinations. First *Pr i r 1*, then *Pr i r 2* then the sum of all connected sensors is displayed.

##### Off



Sensor summing is disabled. A function key set to *Add. L d* (Add Loads) is unnecessary.

Use the following steps to set the Load Totaling parameters.



1. Program an F-key to the *Add. L d* function. See [Section 4.2 on page 21](#). The current channel is displayed.
2. Press *Fx-Add.Ld*. *Add. ALL* is displayed briefly, then the summed total.

Continue pressing *Fx-ttl.r d* to view all enabled sum types.

### 6.3.2 Scan Weight Inputs

1. Program F2 to  $\text{Chan}$  if necessary (F2 is programmed to  $\text{Chan}$  at factory).
2. Program F1 to  $\text{Add. Ld}$  for summed sensor readings. See [Section 6.3.1](#).
3. With the current channel displayed, press  to change display to the next channel. The scan channel number is displayed briefly, then the scan channel weight is displayed.
4. Press . In a two sensor system the  $\text{Chan}$  returns to the first channel (0).

## 6.4 Zero and Tare in Multiple Load Pin Systems

The channel that is displayed is considered the *Focus Channel*. Pressing  or  affects only the displayed channel. When displaying summed channels, ZERO or TARE commands will be sent to all devices that contribute to the displayed weight.

#### *Example:*

*If in the **Both** mode, and displaying pair 1 (sum of SC0 and SC1), pressing ZERO will zero only SC0 and SC1.*

*If displaying the grand total using the **ALL** mode, pressing ZERO will zero all connected sensors.*

#### *Using the Tare function:*

*If one device is tared in the individual display mode, the summed weight will be the sum of a Net and a Gross weight.*

*If TARE is pressed when displaying any of the summed modes, all devices that add to the current display are tared and placed in **Net** mode.*

## 6.5 Communications Port Hardware

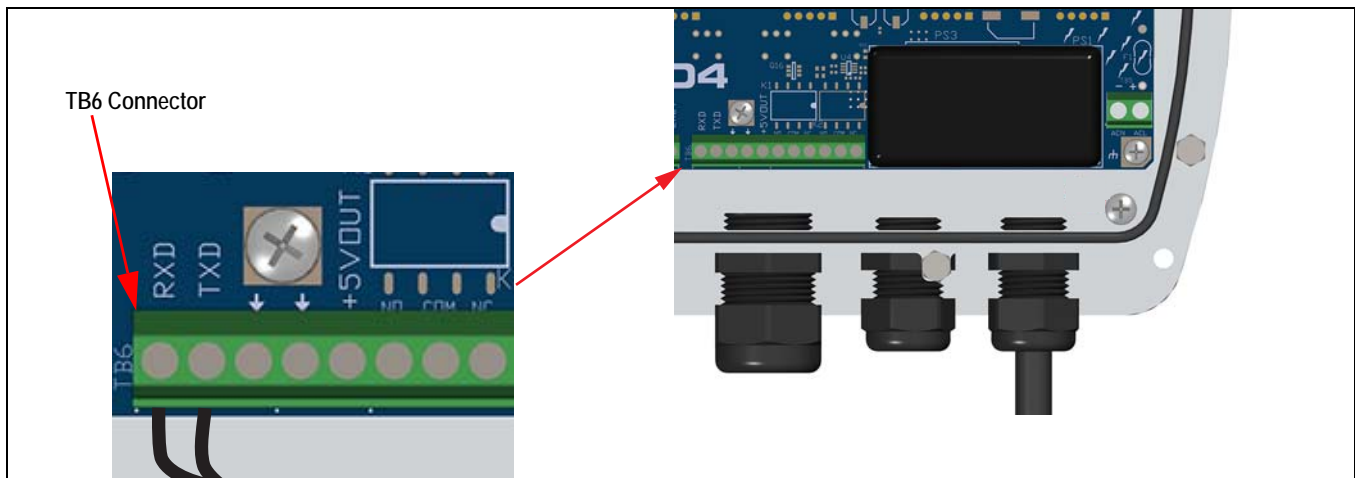

Figure 6-2. Comm Port Wiring

The wires are screwed into the RS-232 terminal block inside the enclosure. Route the cable through a cord grip, the other end should be a nine pin female connector that can then be plugged into a computer or printer's serial port.

The *MSI-8004HD* RS-232 communication port is used for software updates, connecting to a remote display and for connecting to an RS-232 device.

To access the serial connectors and connect the cable, the back cover of the *MSI-8004HD* will first need to be removed. See [Section 3.4 on page 7](#).

To connect to the serial ports, a cable with RS-232 signals brought out to wires on one end and to a standard D9 female serial connector on the other end is required. The wires will need be screwed into terminal block TB6 ([Figure 6-2](#)). Connect to the signals as labeled in the figures 6-3 through 6-5.

**Data Configuration:** The data output is fixed at 8-1-N.

**Baud Rate:** Is set at 38.4 k baud and is not programmable.

**Handshaking:** No hardware handshaking is supported. Xon/Xoff software handshaking is always on.

Comm Port 2 can either be used as a second wired serial port or for the second RF radio module. If the second RF radio module is being used, then the wired comm port 2 must be disabled. The serial port can be enabled or disabled through switch SW10, located on the main circuit board directly above terminal block TB6.

An unterminated cable (PN 143348) is available for wiring a connector to the M12 connector found on the *MSI-8004HD*.

The following diagrams show how to wire standard D9 connectors to access Communications Port 1 or Communications Port 2.

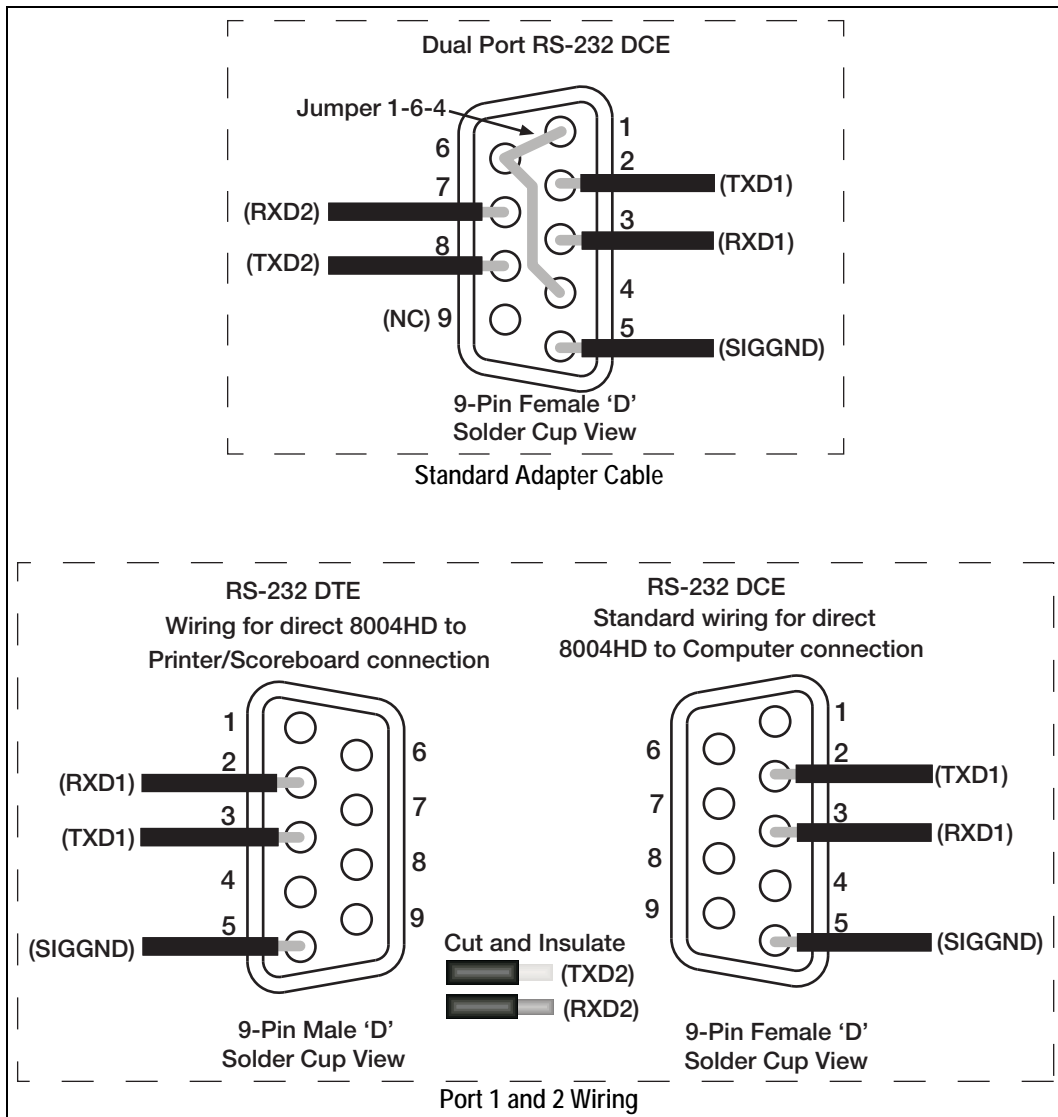

Figure 6-3. Communications Wiring

Wiring the shield drain to the metal shell of the connector is recommended. In some circumstances it may be necessary to disconnect the shield drain wire at the connector frame to prevent ground loops which can cause unstable readings. In extreme cases it may be necessary to use an isolated RS-232 interface.

## 6.6 Relays

The *MSI-8004HD* can be equipped with up to two relays for process control or safety systems.

Two independent relays are factory installed and are wired out to 4 pins on a M12 connector. The connecting cables are shown in [Table 6-10](#).

Part No.	Description
144440	PVC 4 m, rated to 250 VRMS, 4 A
	PVC 10 m, rated to 250 VRMS, 4 A
Alternately use a field wire able connector	
156256	Conn, Female 4 pin field wire able, IP67
	Right angle for 4-6 mm
	Straight for cable 6-8 mm OD
	Right angle 6-8 mm OD

Table 6-10. Relay Connector Cable Part Numbers

### 6.6.1 Relay Options

Relays are normally open (1 Form A). Specifications are listed below.

Relay Type	Description
AC/DC coil relay	<ul style="list-style-type: none"> <li>AC/DC Coil Relay: 144520 PA1a-5 V. 4 A Fuse: 144307</li> <li>AC Rating: 250 VAC @ 5 A. (limited by connector/cordset rating to 5 A continuous)</li> <li>DC Rating: 5 A @ 30 VDC, 0.5 A @ 100 VDC</li> <li>Best choice for 90% of applications.</li> </ul>
AC/DC SSR (solid state relay) - 60V	<ul style="list-style-type: none"> <li>Better for battery powered units and mates well with 24VDC industrial power supplies</li> <li>AC/DC SSR 60 VPK, 2.7 A: 13178 AQZ202D. 2 A Fuse: 144319</li> </ul>
AC/DC SSR - 120V	<ul style="list-style-type: none"> <li>For 115VAC operation when SSRs are preferred.</li> <li>AC/DC SSR 200 VPK. 0.9 A: 13180 AQZ207D. 0.75 A Fuse: 155221</li> </ul>
Other available relays	<ul style="list-style-type: none"> <li>AC/DC SSR 100 VPK, 2 A: 13179 AQZ205D. 1.5 A Fuse: 155220</li> <li>AC/DC SSR 400 VPK, 0.45 A: 13181 AQZ204D. 0.375 A Fuse: 155222 (Use limited to 250VRMS due to connector and Cordset limitations)</li> <li>DC Only SSRs</li> <li>DC SSR 60 VPK, 4 A: 13182 AQZ102D. 3 A Fuse: 155223</li> <li>DC SSR 200 VPK, 1.3 A: 14566 AQZ107D. 1 A Fuse: 160448</li> </ul> <p><i>NOTE: Normally open relays (1 Form A) can be made to function as normally closed (1 Form B) by programming the setpoint as a less than type. If the 8000HD is turned off or loses power, they will open.</i></p>
One 1 Form B closed SSR	<p>AC/DC SSR 400 VPK, 0.5 A: 14628 AQZ404. 0.5 A Fuse 144583 (Use limited to 250 VRMS due to connector and Cordset limitations).</p> <p>Requires a minor modification on the Relay board and can only be ordered by contacting Rice Lake Weighing Systems.</p>

Table 6-11. Relay Options





### 6.6.2 Extended Relay Kit – Optional

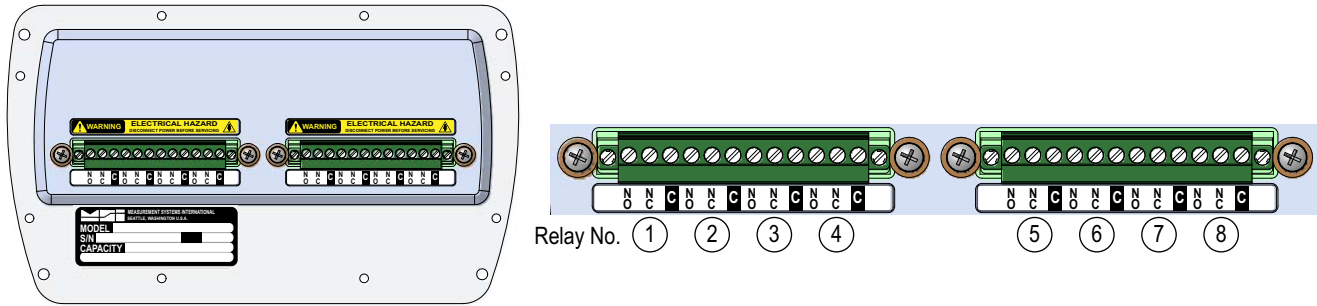

Figure 6-1. Extended Relay Kit:

Part No.	Description
172502	8-CH 0.9A 200VPK SSR FORM C
172501	8-CH 3A 60VPK SSR FORM C
172500	4-CH 3A 60VPK SSR FORM C
172498	8-CH 0.9A 200VPK SSR
172497	8-CH 3A 60VPK SSR
172495	8-CH 12A 5V RELAYS MOMENTARY
172494	4-CH 0.9A 200VPK AC/DC SSR
172493	4-CH 3A 60VPK AC/DC SSR
172492	4-CH 5V MOMENTARY
172490	4-CH 5V LATCHING RELAYS
171676	8-CH 12A RELAYS LATCHING

Table 6-12. Expanded Relay Option Kits

## 6.7 FCC Statement

Contains FCC ID: MCQ-PS2CTH

The *MSI-8004HD* complies with Part 15 of the FCC Rules. Operation is subject to the following conditions:

- This device may not cause harmful interference.
- This device must accept any interference received, including interference that may cause undesired operation.

## 6.8 International RF Certifications

Canada: Radio Certificate Number: IC 1846A-PS2CTH

Australia & New Zealand: DIGI-090F15C247

The product is compliant with the following standards and/or other normative documents:

Safety (article 3.1A) EN60950-1:2001

EMC (article 3.1b) ETSI EN 301 489-1 v1.7.1 (2007-04) In accordance with the specific requirements of ETSI EN 301 489-17 v1.2.1 (2002-08)

Spectrum (article 3.2) ETSI EN 300 328 v1.7.1 (2006-10)

## 6.9 Antenna Options



**Note** To meet FCC licensing rules, use only antennas supplied or recommended by Rice Lake Weighing Systems.

Antenna placement is critical to problem-free use of the system.

- Ensure a relatively clear transmission path exists between the devices to be connected. Radio signals travel primarily by line of sight (LOS), obstructions between stations may degrade the system performance.
- When using the long range antenna, mount the antenna on an elevated structure to ensure there is a clear LOS transmission path. This ensures the antenna will clear surrounding obstructions. Do not provide a ground plane for the antenna.
- Fixed station locations often benefit from directional antennas when the location of the other components of the RF network are fixed and/or in the same direction. Never use a directional antenna on a mobile system.
- If using the standard antenna, ensure the antenna is not blocked by any metal. Transmission is good through most kinds of glass so mounting a meter next to a window will work fine. If there is no clear line of sight location to mount the receiving device, consider switching to the long range antenna so the antenna can be set up remotely.
- The standard and long range antennas are vertical plane devices. They should be vertical, pointing up or down, when high off the ground. Do not mount them sideways. The long range 9 dBi antenna is particularly sensitive to off axis mounting. Use a level to ensure the antenna is exactly 90° perpendicular to the earth.
- Do not mount an omni-directional antenna next to metallic or concrete surfaces. This can result in reflections and undesired RF characteristics. Use a corner reflector instead.
- After installation, seal the antenna connection with an adhesive heat shrink boot. Failure to seal the antenna may result in liquid destroying the antenna and device it's connected to.



*Rice Lake Weighing Systems does not recommend extending the coaxial cable beyond three meters.*

*At 2.4 GHz more loss will result from coax losses than are gained by raising the antenna. If the antenna must be extended, use a very low loss 50 ohm coax such as RG-214, RF-195, or other low loss varieties.*

*For very short extensions (<1m), cables made with RG-316 are suitable.*

### FCC STATEMENT

FCC ID: HSW-2450M

Note: This unit has been tested and found to comply with the limits for a Class A digital device, pursuant to part 15 of the FCC Rules. These limits are designed to provide reasonable protection against harmful interference when the equipment is operated in a commercial environment. This equipment generates, uses, and can radiate radio frequency energy and, if not installed and used in accordance with the instruction manual, may cause interference to radio communications. Operation of this equipment in a residential area is likely to cause harmful interference in which case the user will be required to correct the interference at their expense.



### 6.9.1 Standard Antenna

The standard antenna is an articulated 1/2 wave 2 dBi gain design with a standard TNC connector that mounts directly on the enclosure.

This antenna and coax connector, though resistant to water, is not water-proof. Seal the TNC base with an adhesive heat shrink boot if this antenna might be exposed to rain or other weather conditions where it could get wet.

This antenna must be vertically oriented and is suitable for most short to medium range applications.



### 6.9.2 Long Range OMNI 9 dBi Antenna

This omni-directional high gain antenna is remotely mounted with a low loss coaxial cable and increases the range up to four times.

The antenna must be vertically mounted. The vertical Beamwidth (-3dB point) is 14 degrees.

This antenna is supplied with a 10 foot (3m) coax cable pre-attached. The 10-foot cable allows placement of the antenna above the unit for ease of clearing possible obstacles to data transmission.

It is also available with an N connector for applications requiring longer coax cable lengths.

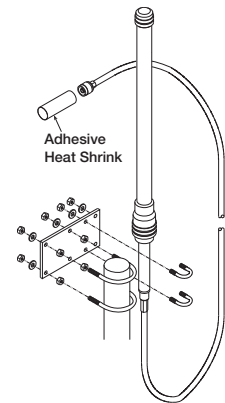

### 6.9.3 Vehicle Mount Whip Antenna

The vehicle mount whip antenna mounts directly to the roof of mobile vehicles and is weatherproof.

This 5 dBi gain whip mounts in a 3/4" hole on the roof of the vehicle.

The mount includes 17' of low loss coax terminated in a TNC connector.



### 6.9.4 YAGI Antenna

For maximum range, a 14 dBi gain Yagi Antenna is available by special order. Please contact Rice Lake Weighing Systems for details.



### 6.9.5 Corner Reflector Antenna

Corner reflector antennas are often the best choice for a wall mounted antenna. Rice Lake Weighing Systems offers a 14 dBi and a 9 dBi corner reflector.



14 dBi Corner Reflector



9 dBi Corner Reflector

### 6.9.6 Patch Antenna

The patch antenna is for applications where the standard antenna is vulnerable to physical damage or outdoor applications.

The patch antenna is mildly directional which requires more care in antenna placement for long range applications. Patch antennas are available by special order only. Please contact Rice Lake Weighing Systems for details.

## 7.0 Troubleshooting and Maintenance

### 7.1 Troubleshooting



Problem	Possible Cause	Solution
Display is blank when the power button is pressed	Discharged battery	Recharge the battery (Battery option only)
	Defective battery	Replace the battery (factory replacement only) (Battery option only)
	Defective switch or circuit board	Requires authorized service
Display does not function properly/front panel buttons do not function normally/indicator doesn't turn off.	Improperly loaded software	Reinstall the software
	Faulty circuit board	Requires authorized service
	Loose connectors	Requires authorized service
Indicator does not respond to tension changes	Out of calibration	Calibrate the unit
	Faulty load pin	Replace the load pin
	Load pin connector	Check connectors and wires
Display over ranges below 100% of capacity	Tared tension is added to load to determine overload point	Return to gross tension mode
	Zero requires adjustment	Re-zero the scale
	Too much tension/load has been zeroed	Re-zero the scale
Display drifts	AZM (Auto 0) is turned off	Turn AZM on
	Rapid temperature changes such as moving the scale from indoors to outdoors	Wait until the scale temperature has stabilized
Displayed tension shows a large error	Scale not zeroed before load is lifted	Zero the scale with no load attached
	lb/kg units causing confusion	Select proper units
	Requires recalibration	Recalibrate the unit
Display reading is not stable	Excessive vibration	Increase filtering or increase $d$ in Cal
	Excessive side loading	Improve load train symmetry
	Load pin faulty	Check load pin connections
Display toggles between <i>Error</i> and <i>Load</i>	Load exceeds capacity	Reduce tension immediately
	Faulty load pin or wiring	Check load pin and load pin wiring
Display toggles between <i>Error</i> and <i>Button</i>	A key is stuck or is being held down	Check switches for damage
Weight is on the indicator and RF Remote Display does not match	Units are not paired	See <a href="#">Section 6.2 on page 38</a>
<i>BT</i> is blinking	The battery is low	Recharge the battery (Battery option only)
Unit turns on, then immediately off	The battery is low	Recharge the battery (Battery option only)
Load will not zero	The system not stable	Wait for stable symbol  to turn on
		Increase filtering for more stability
	Zero out of range	Zero range might be limited. Reduce the tension or use Tare instead
Load will not tare or total	The system not stable	Wait for the stable symbol  to turn on, or if in a mechanically noisy crane, increase the filtering or reduce the size of the scale increment $d$ . It is also possible to increase the motion window. Contact Rice Lake Weighing Systems if there is a problem getting the MSI-8000HD to zero, tare or total due to stability issues
Setpoint lights blink	Set point is enabled and the trigger point has been reached	Disable set points if they are not needed
Manual total does not work	A function key is not set to <i>total</i>	Set up Func1 or Func2 for <i>total</i>
	Tension must be stable	Increase filtering for more stability

Table 7-1. Troubleshooting



Problem	Possible Cause	Solution
The auto total does not work	Load must be stable	Wait for stable symbol  to turn on or increase filtering for more stability
	Load thresholds are not reached	Weight must exceed one percent of capacity for auto total to work. Weight must drop below 0.5% of capacity for additional weightings to register

Table 7-1. Troubleshooting (Continued)

## 7.2 Error Codes

The ScaleCore Processor in the *MSI-8004HD RF Remote Display* detects errors and generates error codes to aid in troubleshooting.



Error Code	Definition	Comment
LcOFF	LC Disabled	A load pin was not enabled
2CAL	In Cal	The system is in calibration mode. Do not send commands unrelated to calibration.
unCAL	Not Calibrated	System has not been calibrated
 Error LoAd	Overload	The load/weight exceeds set capacity +9d, or load pin is damaged or disconnected.
 Error UndLd	Underloaded	The load/weight is more than 20 percent negative, or load pin is damaged or disconnected.

Table 7-2. Error Codes

## 7.3 Service Counters



*Only a Rice Lake Weighing Systems factory representative can reset the service counters, as these are an important safety warning feature. A thorough load train inspection is necessary, prior to resetting service counters, to ensure product safety.*

All Rice Lake RF linked scales/Dyna-Link 2 maintain two service counters for safety.

- The first counter (LFCnt) counts lifts above 25% of capacity.
- The second counter (OLCnt) counts the number of times the RF linked scale has been overloaded.

These counters warn the user to inspect the load train after a number of overloads or a long term frequency of high capacity lifts. Power up will be interrupted when the lift counter exceeds 16383 lifts or the overload counter exceeds 1023 overloads. Inspect the load train, then push any key to continue operation.

This feature is only available on *MSI-8004HD* Software release 2.00 and above. Service counters are available on the scale/Dyna-Link 2 front panel test function.

### 7.3.1 Access the Service Counters

Press  and  simultaneously, the following items display:

- LFCnt displays briefly, followed by the number of lifts
- OLCnt displays briefly, followed by the number of times the weight has exceeded capacity
- E-CAL and its value displays
- The unit returns to the weigh mode



*F1 must be pressed, if the Test function is set to F1, it will need to be pressed twice.*

Reference the Crane Scale Safety and Periodic Maintenance Manual, PN 153105, for proper loading techniques to improve the safety and longevity of the crane scale or Dyna-Link. This publication is available at [www.ricelake.com](http://www.ricelake.com) and is included on the CD shipped with the *MSI-8004HD*.



## 7.4 Mechanical Dimensions

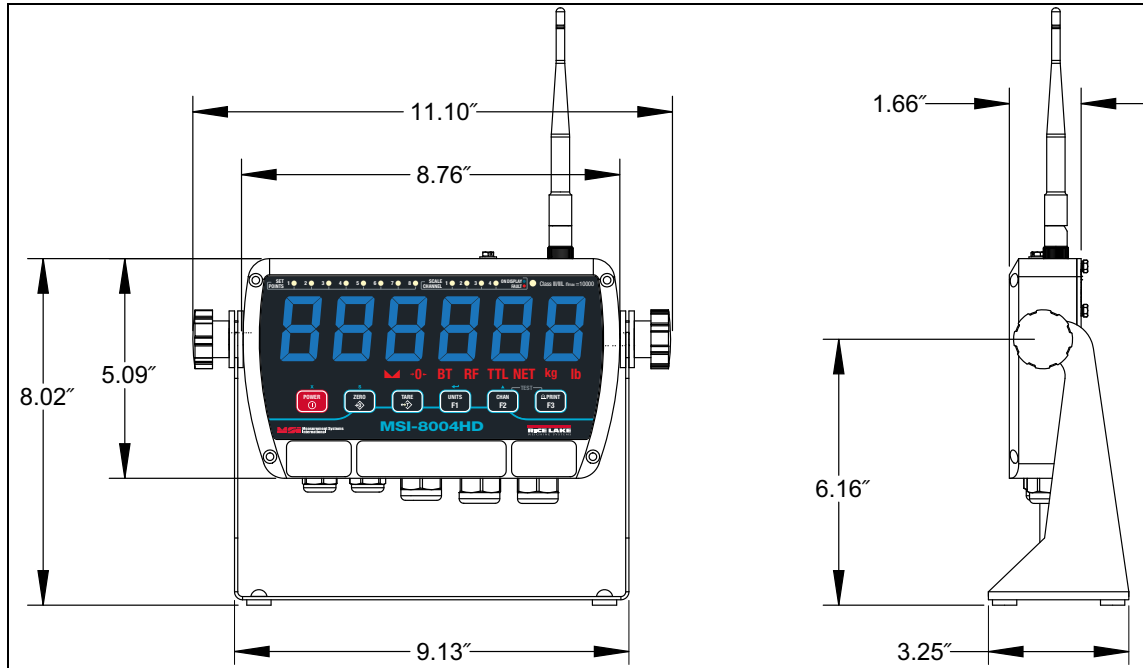

Figure 7-1. Mechanical Dimensions

## 7.5 Firmware Update

Updating firmware in the *MSI-8004HD* requires the following:

- DCE serial cable built per DCE cable schematic
- PC with Rice Lake's MSI ScaleCore Connect Program
- USB to serial converter (if the PC does not have standard RS-232 serial ports)

Ensure the driver for the USB converter is properly installed, and that the terminal program is set up for the proper communications port.

The latest firmware code is available from the Rice Lake Weighing Systems technical support and can be emailed upon request. The firmware version is displayed when the *MSI-8004HD* is turned on as *01-04* (versions will vary). *MSI-8004HD* firmware updates do not require a recalibration of the connected scale. Consult the version release notes for information regarding the updated code.

1. Set up the terminal serial port to 8 data bits, no parity, 1 stop bit, 38400 BAUD, XON/XOFF (flow control).
2. Connect the *MSI-8004HD* to the Dyna-Link serial port using the cable from [Section 6.5 on page 42](#). Connect the D9 connector to a PC or USB adapter.
3. Optional step: Test that there is a connection by typing {00FF01?}. If the connection is good the *MSI-8004HD* will respond with {000001r2;0;01E02;2011-07-08;11:05} or something similar.
4. On the terminal keyboard, type {ffff09=0199}. The *MSI-8004HD* shuts off.
5. Press  to turn the unit on again. The following menu should display.

*MSI-8004HD RF Remote Display SCALECORE2 BOOT LOADER Ver. xx-xx (c) Date, Time*

- (u) Download and program application code  
(the bootloader version may vary)
- (q) query app code info
- (g) execute app code
- (r) refresh



*The bootloader version may vary.*



6. Type **u**.

Terminal should display:

Send File NOW, or press ^ to abort:

7. Send the .prg file using the file send feature of the terminal program. The character # will tick away as the ScaleCore programs.

```
Send File NOW, or press ^to abort:#####
#####
#####
#####
```

Completed

8. After the file is received, the terminal displays *Completed*. Then the boot menu displays again.

MSI-8004HD Rice Lake MSI SCALECORE3 BOOT LOADER Ver. xx-xx (c) Date, Time

- (u) Download and program application code  
(the bootloader version may vary)
- (q) query app code info
- (g) execute app code
- (r) refresh

9. Optional step: send **q** to check the program. The ScaleCore will respond with a message that details the 32b checksum, the product ID and version, and the Application Code version number in the following form:

```
Computed Signature 76F481D8 32b CRC must match (76F481D8 is an example only)
Received Signature 76F481D8
Product ID 07 MSI-8000 product family
Product Version ID 00 Optional features code
App Code Version xx-xx Firmware version number
```

If the CRC Signature does not match, go back to step 4 and try again.

10. Send an **r** to restore the boot menu.

MSI-8004HD Rice Lake MSI SCALECORE3 BOOT LOADER Ver. xx-xx (c) Date, Time

- (u) Download and program application code  
(your bootloader version may vary)
- (q) query app code info
- (g) execute app code
- (r) refresh

11. Send a **g**. The *MSI-8004HD* should start.

## 8.0 Specifications

Enclosure	NEMA Type 4, IP66 milled anodized aluminum with o-ring gaskets
Keypad	On/Off, Zero (100%), Tare, Print, and two user-defined keys for the following functions: peak hold, high resolution, total, view total, net/gross, units switching
Display	6-digit 1.5" (38 mm) LED
Units Displayed	Pounds, kilograms
Annunciators	Stable, COZ, BT, RF, TTL, NET, kg, lb function LEDs. Channels: 1, 2, 3, 4, Setpoints
Power	90-267 VAC, 9-36 VDC, 18-72 VDC, 120-300 VDC
Operating Temp.	-4° F to 140° F (-20°C to 60°C)
RF Remote Channels	Up to four remote sensors, monitored individually, in pairs, or sum all (non-A/D version only)
Service Counters	A/D version only
A/D Inputs	Two independent or summing load pin inputs
Excitation	4.8 V current limited and over-voltage protected
Filtering	Off, Low, Hi-1, Hi-2
RF Radio Link	2.4 GHz 802.15.4
RF Effective Range	Typically 100' (33 m) or more
Data I/O	Dual RS-232 comm ports
Warranty	One-year limited
Optional	Bluetooth, Wi-Fi

### Approvals:



NTEP COC #17-036  
 $\pi_{max}$ : 10 000  
 Accuracy Class: III / III L









© Rice Lake Weighing Systems Specifications subject to change without notice.  
Rice Lake Weighing Systems is an ISO 9001 registered company.

230 W. Coleman St. • Rice Lake, WI 54868 • USA  
U.S. 800-472-6703 • Canada/Mexico 800-321-6703 • International 715-234-9171 • Europe +31 (0)26 472 1319