

Rice Lake Mechanical Chair Scale

Model RL-MCS, RL-MCS-10

Operation Instructions



RICE LAKE[®]
WEIGHING SYSTEMS
To be the best by every measure[®]

Contents

- 1.0 Introduction..... 1**
- 2.0 Installation Instructions..... 2**
 - 2.1 Pillar and Beam Installation 2
 - 2.2 Steelyard Rod Connection 3
 - 2.3 Installing Transport Handle 4
 - 2.4 Seat and Footrest Installation 5
 - 2.5 Arm Rest Installation. 6
- 3.0 Zero Adjustment..... 8**
- For More Information 9**
- Chair Scale Limited Warranty..... 10**

 *Technical training seminars are available through Rice Lake Weighing Systems. Course descriptions and dates can be viewed at www.ricelake.com or obtained by calling 715-234-9171 and asking for the training department*



Rice Lake continually offers web-based video training on a growing selection of product-related topics at no cost. Visit www.ricelake.com/webinars.

1.0 Introduction

The Rice Lake Mechanical Chair Scale is designed for the mobile challenged who have a difficult time standing on a conventional scale. It is ideal for use in clinics and nursing facilities. The scale is durable, having a sturdy enameled steel body, a durable molded plastic seat, heavy-duty footrest, and heavy-duty caster wheels for easy portability.

The Rice Lake Mechanical Chair Scale comes in two models:

- RL-MCS: lb/kg (440 lb (200 kg) capacity)
- RL-MCS-10: lb only (450 lb capacity)



Internet

This manual can be viewed and downloaded from the Rice Lake Weighing Systems web site at www.ricelake.com/health. Rice Lake Weighing Systems is an ISO 9001 registered company.

Additional information for the RL-MCS series scale can be found on the following link and selecting Rice Lake mechanical chair scale:

<http://www.Ricelakehealth.com/video>



Figure 1-1. Mechanical Chair Scale

2.0 Installation Instructions

You will receive your Mechanical Chair Scale partially assembled. Those items that need additional assembly are:

- Pillar and beam assembly to scale base
- Steelyard rod connection
- Transport handle onto scale base
- Seat and footrest installation
- Arm rest installation

Remove all components from the shipping crate and lay out in a convenient place.

2.1 Pillar and Beam Installation

The pillar and beam comes separate from the scale base and must be attached prior to use.

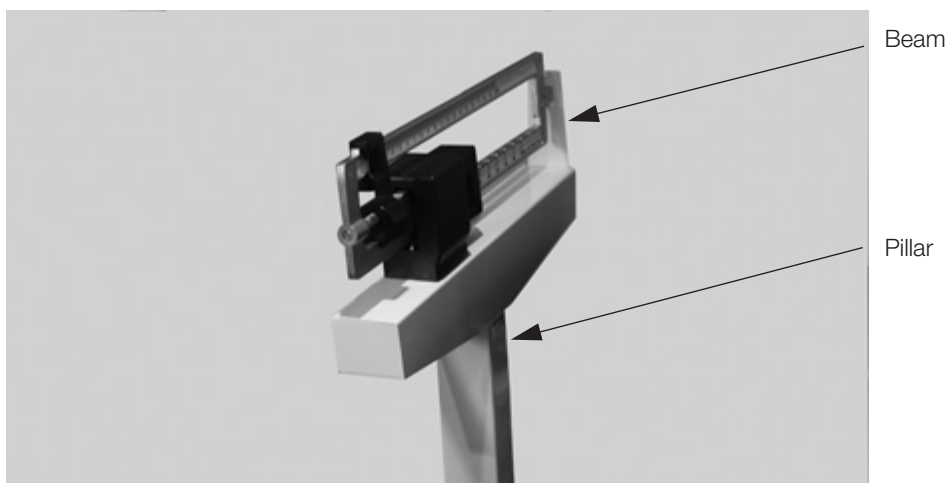

Figure 2-1. Pillar and Beam Components

Use the following steps to attach the pillar and beam to the scale base.

1. Have the scale sitting on the floor in an area that allows you to work freely.
2. Lock casters on the frame to eliminate the unit from rolling while assembling the scale.

Push down on latching assembly to lock wheels and prevent scale from rolling.

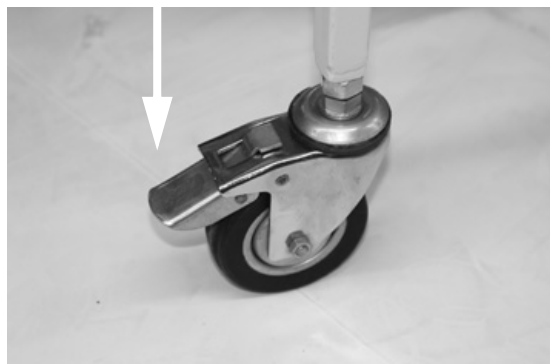

Figure 2-2. Lock Casters to Keep From Rolling

3. Remove the eight screws from the scale base using a Phillips head screwdriver (as shown in the left hand photo) and set screws aside in a safe place.



Figure 2-3. Remove Screws From Scale Base and Insert Pillar and Beam into Scale Base Assembly

Insert, **but don't fasten** the pillar and beam into the scale base assembly as shown in Figure 2-3 (right hand side photo).

2.2 Steelyard Rod Connection

The steelyard rod is located inside the pillar. **Remove the wire tie(s) holding the steelyard rod during shipment.** Insert the pillar into the base. Once the pillar is inserted to the scale base, the steelyard rod must be attached to the bottom of the scale. The two photos in Figure 2-4 show the hook of the steelyard rod and an inside photo of the ring in the scale bottom. Latch the hook onto the D-shaped ring shown in the right hand side picture.

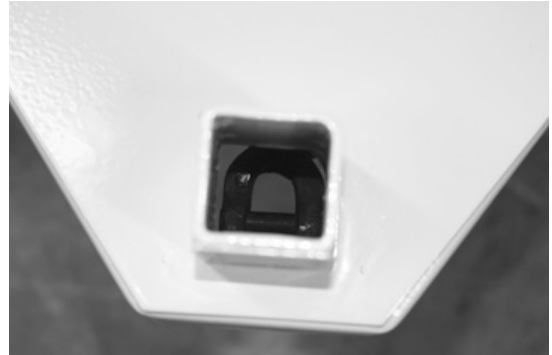
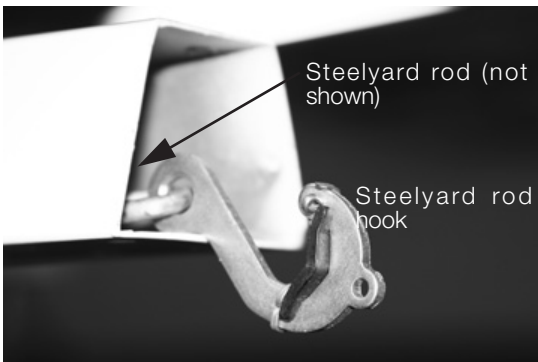

Figure 2-4. Attach The Steelyard Rod To the Scale Base D-Ring

Fasten the eight screws once the pillar and beam is connected to the scale base and the steelyard rod is hooked.



Figure 2-5. Insert and Tighten The Eight Screws

2.3 Installing Transport Handle

Once the pillar and beam are attached to the scale support frame and secured, it's time to attach the transport handle to the scale support frame (transport handle is illustrated in Figure 2-6).

1. Remove the four side screws (two on each side as shown in left hand side of Figure 2-6) from the scale support frame and set aside. The transport handle will attach to the scale support frame using those screws.

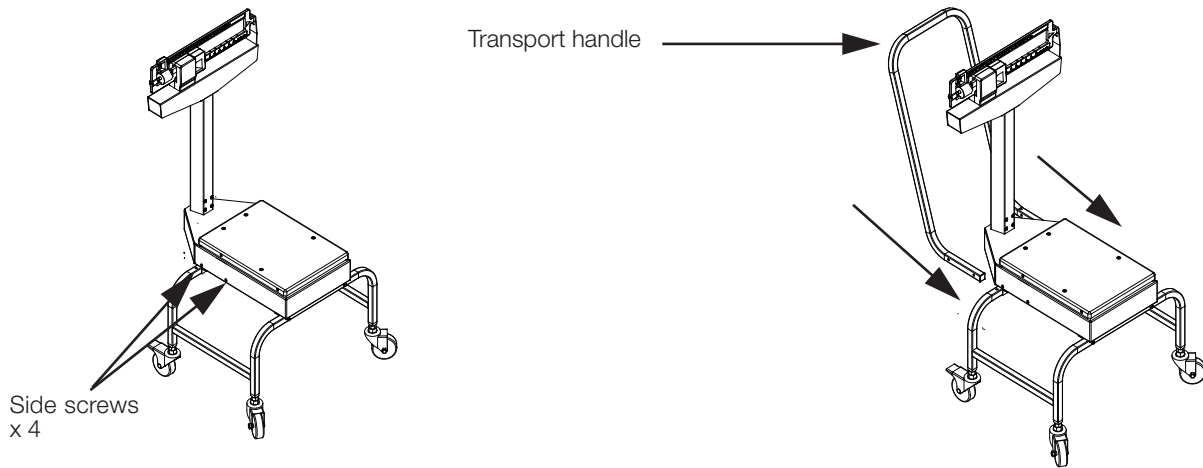

Figure 2-6. Transport Handle Installation

2. Insert the transport handle into the two sides of the scale support frame (shown in right side of Figure 2-6).
3. Insert and tighten the four screws using a Phillips screwdriver as shown in Figure 2-7.



Figure 2-7. Insert and Tighten Four Screws for Securing the Transport Handle to the Scale Support Frame

The transport handle should fit snugly against the scale support frame.

2.4 Seat and Footrest Installation

Once the transport handle is attached the next step is to install the molded seat to the scale support frame.

1. Remove the four screws from the movable scale support frame platform and set aside.



Four screws on scale support frame - only one screw shown

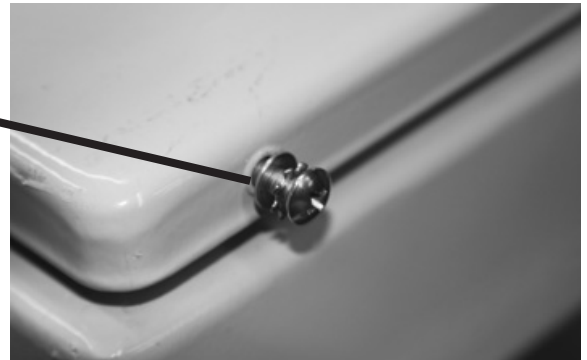
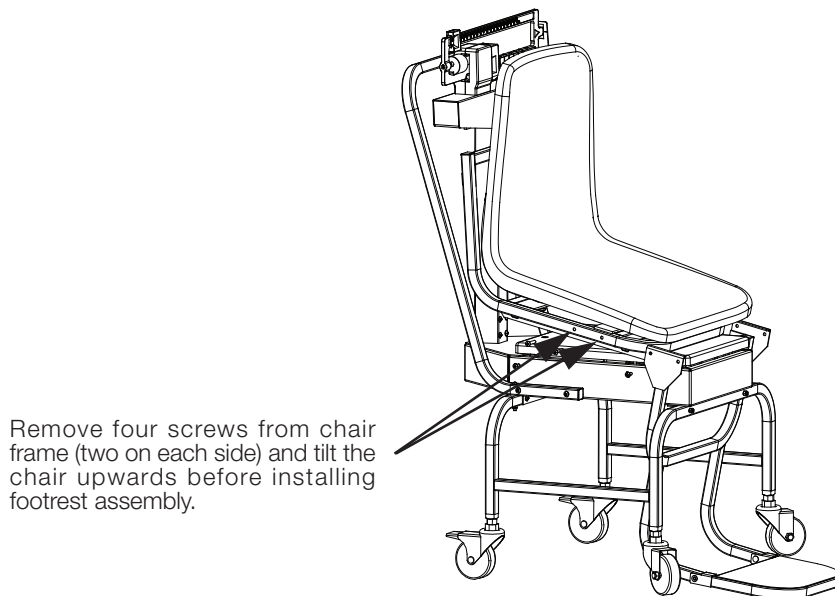

Figure 2-8. Removable Screws on The Movable Scale Support Frame

2. Set the chair onto the scale support frame platform but **do not** fasten the screws as the footrest assembly will also have to be put into place prior to tightening all screws.
3. Remove screws from the chair frame (shown in Figure 2-9) and set aside.
4. Tilt the chair upwards as shown in Figure 2-9. This will allow the installer to get the footrest assembly in place prior to securing the chair to the platform.



Remove four screws from chair frame (two on each side) and tilt the chair upwards before installing footrest assembly.

Figure 2-9. Tilt the Chair Upward Before Installing the Footrest Assembly

5. Slide the footrest assembly onto the chair scale base as shown in Figure 2-9.
Note that the footrest assembly for the footrest is hanging on the metal chair channel and lined up with the screw holes on the channel of the chair scale frame as shown in Figure 2-10.



Push footrest assembly back so that the holes line up.

Figure 2-10. Slide the Footrest Assembly So That Holes Line Up

Once the footrest is secured and the screws tightened for it, secure the molded seat onto the chair scale frame.

- 6. Secure the four screws (shown below).

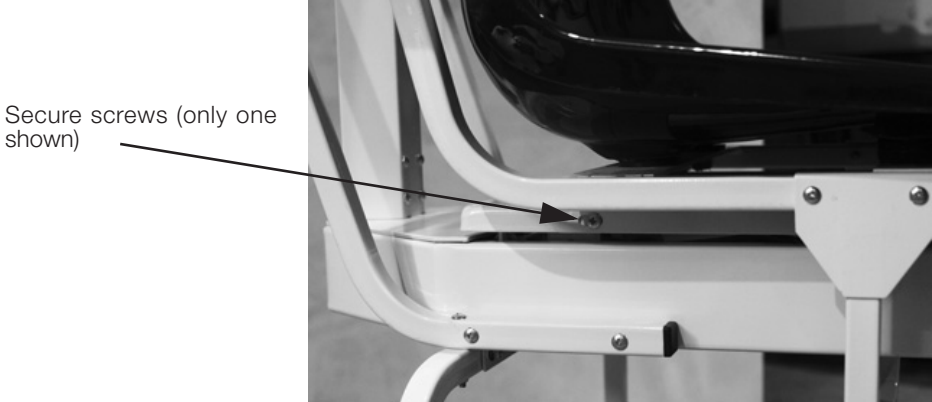

Figure 2-11. These Screws Hold The Molded Chair to the Scale Base

2.5 Arm Rest Installation

The last item to be installed on the mechanical chair scale are the two arm rests.



Figure 2-12. Detachable Arm Rest for the Mechanical Chair Scale

Use the following steps to attach the two arm rests to the mechanical chair scale molded seat.

1. Locate the bolt hole (x 4) location on the back of the molded chair.

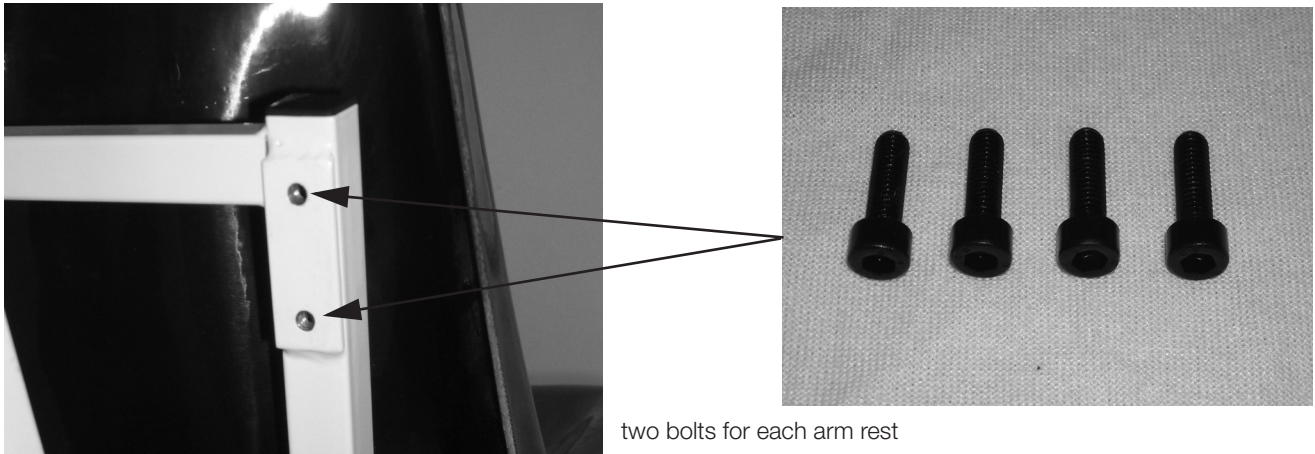

Figure 2-13. Hole Location and Four Bolts Used for Securing Arm Rest to Chair

2. Secure the arm rests to the molded chair using the four bolts (provided and shown in Figure 2-13), using the 5mm allen wrench that's been provided in this packaging.

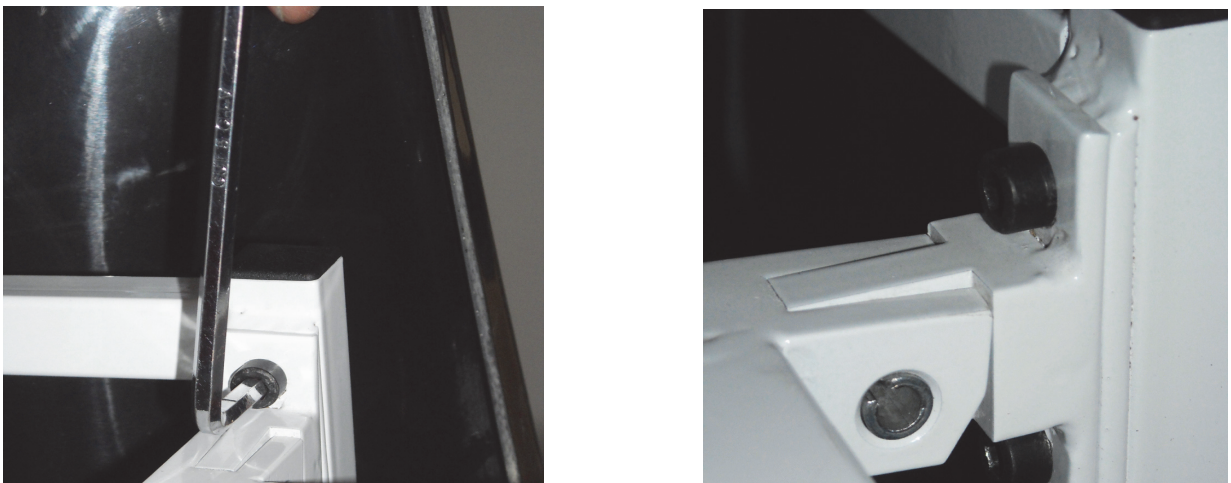

Figure 2-14. Secure Arm Rests to the Molded Chair

3. The arm rests are now in position and can be moved up and down.

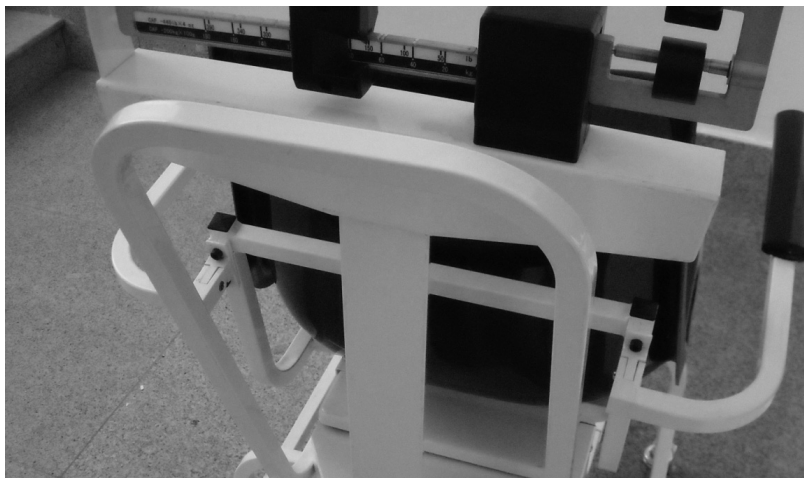

Figure 2-15. Arm Rests Are Secured to the Molded Chair Seat

3.0 Zero Adjustment

To ensure accurate weighments, a zero adjustment should be done to the scale upon arrival and setup. To perform a zero adjustment, perform the following steps.

1. Ensure the scale is sitting on a level surface.
2. Check the eye loop area of the scale to ensure that the scale pointer is equally balanced between the eye loop area.



Figure 3-1. Eye Loop Area and Zero Adjusting Screw Location (Lb/Kg model shown)

3. If the scale is not balancing properly, then the small zero balance weight must be adjusted. Turn the zero adjusting screw (shown in Figure 3-1) using a flat head screwdriver. By adjusting the screw, the zero balance weight will move accordingly.
4. The scale is now ready to weigh patients.
5. Have the patient sit down on the molded seat. **The patient should be completely seated in the chair, not leaning forward, and having feet firmly positioned on the footrest assembly.**



Important

For units having both lb/kg weighing capability, ensure that the large poise weights sits directly above the desired weight reading on the weigh beam. Note that lb readings are in white and kg readings are in black.

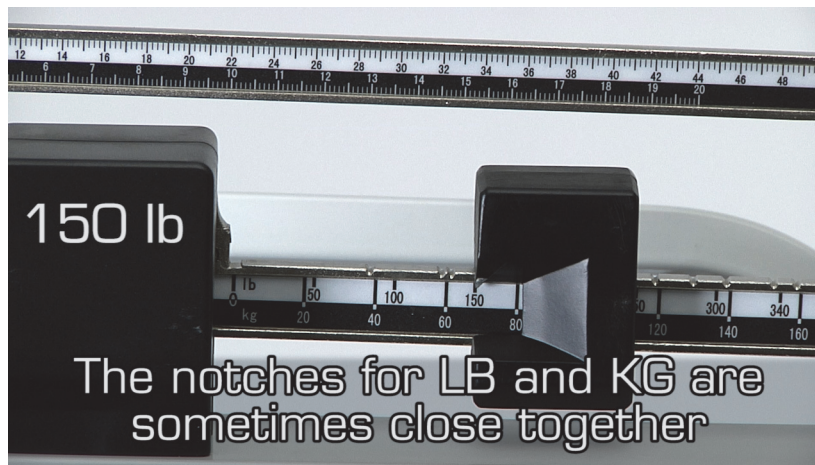

For More Information

Literature

- *Medical Scales - Mechanical Chair Scale*, PN 114086

Web Site

- <http://www.ricelake.com/medical>
- <http://www.ricelake.com/health>

Contact Information

Hours of Operation

Knowledgeable customer service representatives are available 6:30 a.m. - 6:30 p.m. Monday through Friday and 8 a.m. to 12 noon on Saturday. (CST)

Telephone

- Sales/Technical Support 800-472-6703
- Canadian and Mexican Customers 800-321-6703
- International 715-234-9171

Fax

- Fax Number 715-234-6967

Email

- U.S. sales and product information at proinfo@ricelake.com
- International (non-U.S.) sales and product information at intlsales@ricelake.com

Mailing Address

Rice Lake Weighing Systems
230 West Coleman Street
Rice Lake, WI 54868 USA

Chair Scale Limited Warranty

Rice Lake Weighing Systems warrants that all RLWS equipment and systems properly installed by a Distributor or Original Equipment Manufacturer (OEM) will operate per written specifications as confirmed by the Distributor/OEM and accepted by RLWS. All systems and components are warranted against defects in materials and workmanship for two years.

RLWS warrants that the equipment sold hereunder will conform to the current written specifications authorized by RLWS. RLWS warrants the equipment against faulty workmanship and defective materials. If any equipment fails to conform to these warranties, RLWS will, at its option, repair or replace such goods returned within the warranty period subject to the following conditions:

- Upon discovery by Buyer of such nonconformity, RLWS will be given prompt written notice with a detailed explanation of the alleged deficiencies.
- Examination of such equipment by RLWS confirms that the nonconformity actually exists, and was not caused by accident, misuse, neglect, alteration, improper installation, improper repair or improper testing; RLWS shall be the sole judge of all alleged non-conformities.
- Such equipment has not been modified, altered, or changed by any person other than RLWS or its duly authorized repair agents.
- RLWS will have a reasonable time to repair or replace the defective equipment. Buyer is responsible for shipping charges both ways.
- In no event will RLWS be responsible for travel time or on-location repairs, including assembly or disassembly of equipment, nor will RLWS be liable for the cost of any repairs made by others.

THESE WARRANTIES EXCLUDE ALL OTHER WARRANTIES, EXPRESSED OR IMPLIED, INCLUDING WITHOUT LIMITATION WARRANTIES OF MERCHANTABILITY OR FITNESS FOR A PARTICULAR PURPOSE. NEITHER RLWS NOR DISTRIBUTOR WILL, IN ANY EVENT, BE LIABLE FOR INCIDENTAL OR CONSEQUENTIAL DAMAGES.

RLWS AND BUYER AGREE THAT RLWS'S SOLE AND EXCLUSIVE LIABILITY HEREUNDER IS LIMITED TO REPAIR OR REPLACEMENT OF SUCH GOODS. IN ACCEPTING THIS WARRANTY, THE BUYER WAIVES ANY AND ALL OTHER CLAIMS TO WARRANTY.

SHOULD THE SELLER BE OTHER THAN RLWS, THE BUYER AGREES TO LOOK ONLY TO THE SELLER FOR WARRANTY CLAIMS.

NO TERMS, CONDITIONS, UNDERSTANDING, OR AGREEMENTS PURPORTING TO MODIFY THE TERMS OF THIS WARRANTY SHALL HAVE ANY LEGAL EFFECT UNLESS MADE IN WRITING AND SIGNED BY A CORPORATE OFFICER OF RLWS AND THE BUYER.

© 2012S Rice Lake Weighing Systems, Inc. Rice Lake, WI USA. All Rights Reserved.

RICE LAKE WEIGHING SYSTEMS • 230 WEST COLEMAN STREET • RICE LAKE, WISCONSIN 54868 • USA



230 W. Coleman St. Rice Lake, WI 54868 USA
U.S. 800-472-6703 Canada/Mexico 800-321-6703 International 715-234-9171 Europe +31 (0) 88 2349171

www.ricelake.com www.ricelake.mx www.ricelake.eu www.ricelake.co.in m.ricelake.com

PN 111372 - Rev A 02/14