

Tracer® AV2

Baggage Weighing Instrumentation



Approvals



Ideal for baggage weighing, Tracer AV2 combines a sleek five-button keypad with the most durable stainless steel display. The simple-to-install display features a large, backlit LCD display and the rugged keypad will endure years of busy check-in counter use.

Part Number/Price

Part #	Description	Price
202532	Tracer AV2, single LCD panel mount display, single keypad	Consult
202531	Tracer AV2, dual LCD panel mount display, single keypad	Consult
207287	Tracer AV2, dual LCD panel mount display, dual keypad	Consult
204452	Tracer AV2, single LCD external mount display, single keypad	Consult
204451	Tracer AV2, dual LCD external mount display, Single keypad	Consult

To complete your system, refer to page 184 for the BenchMark LP or page 185 for the BenchMark HD scales

Replacement Parts

Part #	Description	Price
205206	Tracer AV2 CPU module	Consult
207288	Kit, RD2 LCD display	Consult
207289	Kit, RD2 LCD display, external mount package	Consult
207290	Kit, five-button keypad	Consult
15438	Power cord, detachable, 7.5 ft long	Consult
203937	Power supply, 7.5V 30W	Consult
207302	Cable splitter, DB9 female to DB9 male connector	Consult

Standard Features

- Customer display (panel mount)
- CPU module
- Supports two displays (customer/agent)
- Five-button keypad for ticket agent
- Accumulation function
- Display indicates overweight bag

Specifications

Power:

115 to 230 VAC to CPU module
50/60 Hz

Power Consumption:

6 W

Excitation Voltage:

5 VDC, 8 x 350 ohm load cells

Analog Signal Input Range:

-0.5 mV/V to 4.5 mV/V

Analog Signal Sensitivity:

1 µV/graduation recommended

A/D Sample Rate:

6.25 to 120 Hz, software selectable

Resolution:

Internal: 8,000,000 counts
Display: 1,000,000

System Linearity:

Within 0.01% full scale

Communication:

Ethernet TCP/IP
USB Device

Annunciators:

lb/kg

Display:

Stainless steel, panel mounted, seven-digit LCD display, 0.8 in (20 mm) tall digits

Keys/Buttons:

Zero, Units, Accum, Print, Enter

Temperature Range:

14 °F to 104 °F (-10 °C to 40 °C)

Dimensions:

Panel Mount Display:

7.5 × 4.0 × 1.49 in
(19.05 × 10.16 × 3.79 cm)

External Mount Display:

7.5 × 3.9 × 1.44 in
(19.05 × 9.91 × 3.66 cm)

Panel Mount Keypad:

4.0 × 2.5 × 2.1 in
(10.16 × 6.35 × 5.33 cm)

CPU Enclosure:

7.5 × 7.0 × 2.25 in without mounting feet
11.13 × 7.0 × 3.06 in with mounting feet

Weight:

5.25 lb

Warranty:

Two-year limited

Approvals:

NTEP 21-015, Class III/IIIL, 10,000d
Measurement Canada AM-6168C
cULus

Dimensions

CPU Enclosure Assembly

A	7.30 in (18.55 cm)	F	11.10 in (28.20 cm)
B	7.00 in (17.78 cm)	G	2.40 in (6.10 cm)
C	3.20 in (8.13 cm)	H	10.00 in (25.40 cm)
D	8.00 in (20.32 cm)	I	4.50 in (11.43 cm)
E	7.50 in (19.05 cm)		

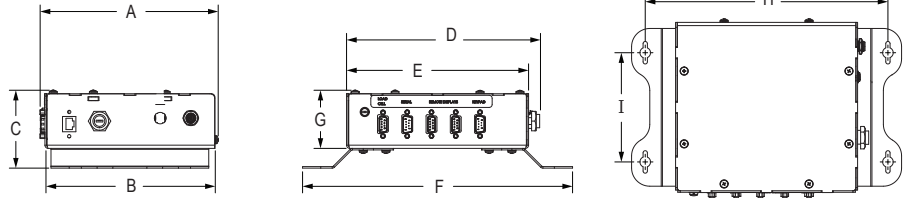

Remote Keypad (Panel Mount)

A	4.00 in (10.16 cm)	E	1.90 in (4.83 cm)
B	2.50 in (6.35 cm)	F	1.38 in (3.51 cm)
C	1.98 in (5.03 cm)	G	4.63 in (11.76 cm)
D	0.063 in (0.16 cm)	H	2.60 in (6.61 cm)

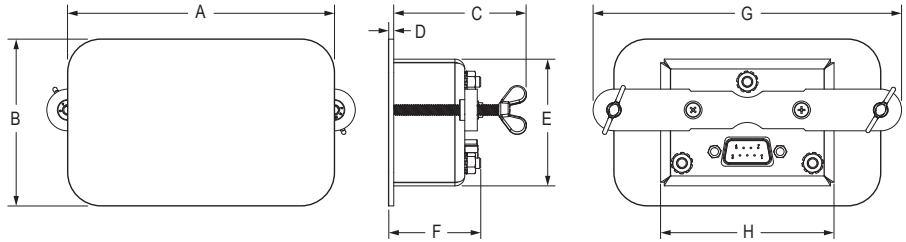

Remote Display (Panel Mount)

A	7.50 in (19.05 cm)	E	1.00 in (2.54 cm)
B	4.00 in (10.16 cm)	F	0.063 in (0.16 cm)
C	7.00 in (17.78 cm)	G	1.33 in (3.38 cm)
D	2.22 in (5.64 cm)	H	1.49 in (3.79 cm)

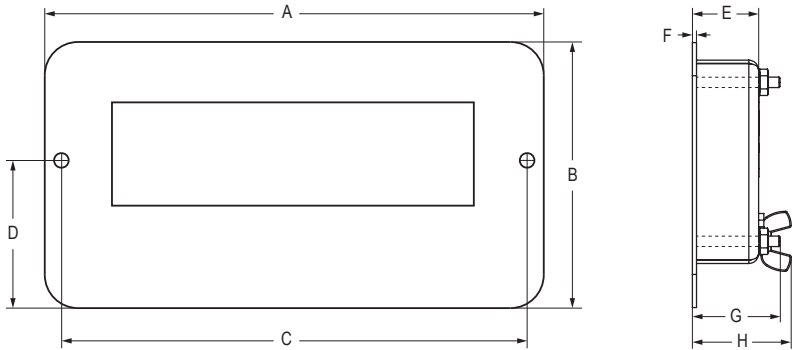

Remote Display (External Mount)

A	7.50 in (19.05 cm)	E	1.44 in (3.66 cm)
B	3.90 in (9.91 cm)	F	1.29 in (3.28 cm)
C	6.22 in (15.80 cm)	G	1.00 in (2.54 cm)
D	1.95 in (4.96 cm)		

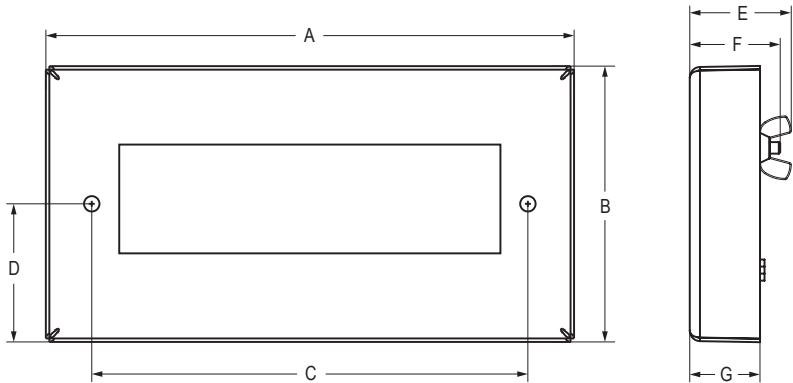

AVIATION