

# TA Plus

*Tuning Fork Analytical Balance*

## Operation Manual



An ISO 9001 registered company  
© Rice Lake Weighing Systems. All rights reserved.

Rice Lake Weighing Systems® is a registered trademark of  
Rice Lake Weighing Systems.

All other brand or product names within this publication are trademarks or  
registered trademarks of their respective companies.

All information contained within this publication is, to the best of our knowledge, complete and  
accurate at the time of publication. Rice Lake Weighing Systems reserves the right to make  
changes to the technology, features, specifications and design of the equipment without notice.

The most current version of this publication, software, firmware and all other product  
updates can be found on our website:

[www.ricelake.com](http://www.ricelake.com)

# Contents

<b>1.0</b>	<b>Introduction</b>	<b>1</b>
1.1	Safety	1
1.2	Standard Features	2
1.3	Capacities and Options	2
1.3.1	Options/Accessories	2
<b>2.0</b>	<b>Installation</b>	<b>3</b>
2.1	Measuring Environment Precautions	3
2.2	Balance Main Unit Precautions	3
2.3	Unpack Balance	4
2.4	Leveling the Balance	5
<b>3.0</b>	<b>Operation</b>	<b>6</b>
3.1	Front Panel	6
3.2	Annunciators	7
3.3	Precautions Related to a Specimen	8
3.4	Display Navigation	8
3.5	Power On/Off	8
3.5.1	Balance Operation Check	8
3.6	Zero-Point Adjustment	9
3.6.1	Zero-Point Adjustment Limits	9
3.7	Tare Value	9
3.7.1	Preset Tare	9
3.7.2	Check Tare Weight Using an F-Key	10
3.7.3	Add to Product	10
3.8	Weigh Mode	11
3.9	Counting Mode	11
3.9.1	Actual Value Setting—No Change	12
3.9.2	Numeric Value Setting Method	12
3.10	Percentage Mode	13
3.11	Multiplied By a Coefficient Mode	14
3.12	Specific Gravity Mode	15
3.12.1	Menus Available in Operation Mode	15
3.12.2	Materials Required in Specific Gravity Mode	15
3.12.3	Prepare Equipment to Measure Specific Gravity	15
3.12.4	Measure the Specific Gravity Mode	16
3.13	Unit Setting	16
3.14	Comparator Function	17
3.15	Addition Function	17
3.15.1	Plus Side Addition	18
3.15.2	Weighing with Minus Side Addition	18
3.15.3	View/Delete Total Value	19
3.16	Tare-Subtraction Reminder Function	19
3.16.1	Set Tare-Subtraction Reminder Function	19
3.17	Zero-Point-Adjustment Reminder Function	19
3.17.1	Set Zero-Point-Adjustment Reminder Function	19
3.18	Stabilization Wait Function	20
3.18.1	Set Stabilization Wait Function	20
3.19	Bar Graph Display	20



Technical training seminars are available through Rice Lake Weighing Systems. Course descriptions and dates can be viewed at [www.ricelake.com/training](http://www.ricelake.com/training) or obtained by calling 715-234-9171 and asking for the training department.

3.20	Back Light Display	21
3.21	Auto Off Function	21
3.22	Simple Self Counting System (SCS) Method	22
3.22.1	Set SCS Method	22
<b>4.0</b>	<b>Span Test and Calibration</b>	<b>23</b>
4.1	Span Adjustment	24
4.1.1	Span Adjustment with External Weight	24
4.1.2	Span Test with External Weight	24
4.1.3	Semi-Automatic Span Adjustment with Internal Weights	25
4.2	Span Test	25
4.2.1	Span Test with Internal Weights	25
4.2.2	Automatic Repeatability Measurement (ARM)	25
4.2.3	Calibrating the Internal Weight	26
4.2.4	Restore the Internal Weight Calibration Value to Default	26
4.2.5	Advice CAL and Automatic Span Adjustment	26
4.2.6	Weight Error Input	27
4.2.7	Weight Error Reflection	27
<b>5.0</b>	<b>Configuration</b>	<b>28</b>
5.1	General Navigation	28
5.2	Application Menu	29
5.2.1	Operation Modes	30
5.2.2	Units	31
5.2.3	Comparator Menu	32
5.2.4	Addition	33
5.3	Performance Menu	34
5.3.1	Stability	35
5.3.2	Response Speed	36
5.3.3	Zero Tracking	36
5.4	User Information	37
5.4.1	Preset Tare Mode	37
5.4.2	Input Preset Tare Value	38
5.4.3	Set the Discrimination Value of Comparator Function	38
5.5	External Input/Output Functions	40
5.6	Lock Functions	42
5.6.1	Total Lock Release	42
5.6.2	Key Lock Function	42
5.6.3	Menu Lock Function	43
5.7	Admin/Adjust Menu	44
5.7.1	Set Short Cut Mode	45
5.7.2	Set Free Keys	45
5.7.3	Maintenance Settings	46
5.7.4	Balance Manage Menu	47
<b>6.0</b>	<b>Scale Control and Adjustments</b>	<b>48</b>
6.1	Measuring Mode Shortcuts	48
6.2	Free Key	49
6.3	Balance Control Setting	50
6.3.1	Balance ID Setting	50
6.3.2	Password Control	51
6.3.3	Set Administrative Password	51



Rice Lake continually offers web-based video training on a growing selection of product-related topics at no cost. Visit [www.ricelake.com/webinars](http://www.ricelake.com/webinars)

# Contents

6.3.4	Set User Password . . . . .	51
6.3.5	Outputting the Span Adjustment Result . . . . .	51
6.3.6	Date Indication Format . . . . .	52
6.3.7	Date Setting . . . . .	52
6.3.8	Time Setting . . . . .	52
6.3.9	Output Language . . . . .	52
6.3.10	Readability Setting . . . . .	53
6.3.11	Auto Span Adjustment with Internal Weight on Power up . . . . .	53
6.3.12	Direct Start Setting . . . . .	53
6.3.13	Resetting to Factory Settings . . . . .	54
<b>7.0</b>	<b>Communications . . . . .</b>	<b>55</b>
7.1	RS-232 Connections . . . . .	55
7.2	Basic Data Output Format . . . . .	56
7.2.1	Data Description . . . . .	56
7.3	CBM Data Output Format . . . . .	57
7.3.1	CBM Data Description . . . . .	57
7.4	Input Commands . . . . .	59
7.4.1	Input Command Composition 1 . . . . .	59
7.5	Command Formats . . . . .	60
7.5.1	Input Command Composition 2 . . . . .	61
7.6	Response . . . . .	62
7.7	External Contact Input . . . . .	62
7.8	Communication Settings . . . . .	62
7.9	Set Communication Parameters . . . . .	63
7.9.1	Optional Relay Contact Output . . . . .	63
7.10	Print Examples . . . . .	64
<b>8.0</b>	<b>Troubleshooting and Maintenance . . . . .</b>	<b>65</b>
8.1	Precautions Related to the Main Unit of the Balance . . . . .	65
8.2	Error Messages . . . . .	66
8.3	Basic Maintenance . . . . .	68
8.3.1	Cleaning . . . . .	68
8.3.2	Dimensions . . . . .	68
8.4	Specifications . . . . .	69
8.4.1	Basic Communication Specification . . . . .	69
8.4.2	Model Specifications . . . . .	69
8.4.3	Functional Specifications . . . . .	70
<b>9.0</b>	<b>Appendix . . . . .</b>	<b>71</b>



Technical training seminars are available through Rice Lake Weighing Systems. Course descriptions and dates can be viewed at [www.ricelake.com/training](http://www.ricelake.com/training) or obtained by calling 715-234-9171 and asking for the training department.



*Rice Lake continually offers web-based video training on a growing selection of product-related topics at no cost. Visit [www.ricelake.com/webinars](http://www.ricelake.com/webinars)*

# 1.0 Introduction

This manual is intended for use by customers and service technicians responsible for installing and operating the Rice Lake TA Plus balance. Configuration and calibration of this balance can be accomplished using the TA Plus' front panel keys.



Manuals and additional resources are available from the Rice Lake Weighing Systems website at [www.ricelake.com](http://www.ricelake.com)

Warranty information can be found on the website at [www.ricelake.com/warranties](http://www.ricelake.com/warranties)

## 1.1 Safety

### Safety Signal Definitions:



**DANGER** Indicates an imminently hazardous situation that, if not avoided, will result in death or serious injury. Includes hazards that are exposed when guards are removed.



**WARNING** Indicates a potentially hazardous situation that, if not avoided, could result in serious injury or death. Includes hazards that are exposed when guards are removed.



**CAUTION** Indicates a potentially hazardous situation that, if not avoided, could result in minor or moderate injury.



**IMPORTANT** Indicates information about procedures that, if not observed, could result in damage to equipment or corruption to and loss of data.

### General Safety



**Do not operate or work on this equipment unless this manual has been read and all instructions are understood. Failure to follow the instructions or heed the warnings could result in injury or death. Contact any Rice Lake Weighing Systems dealer for replacement manuals.**



**Failure to heed could result in serious injury or death.**

**Ensure every individual operating or working with this balance has read and understands the following safety information.**

**Do not allow minors (children) or inexperienced persons to operate this balance.**

**Prior to cleaning, make sure the balance is disconnected from the power source.**

**Do not use this product if any of the components are loose or cracked.**

**Do not use in the presence of flammable materials.**

**Do not use near water and avoid contact with excessive moisture.**

**Do not drop the balance or subject it to violent shocks.**

**Do not make alterations or modifications to the balance.**

**For accurate weighing, the balance must be placed on a stable, level surface.**

**Do not use balance in wet or dusty locations.**

**Do not use balance or AC adapter with wet hands**

**Review MSDS (Material Safety Data Sheets) when applicable.**

**Only use the specified power supply supplied by Rice Lake Weighing Systems.**

**Do not use in an explosive environment.**

## 1.2 Standard Features

- Anti-electrostatic 360° transparent windshield
- Eight-digit, 16.5mm-high liquid crystal display (LCD) with backlight
- Single-touch response setting for environment
- 40-step bar graph display
- RS-232C interface
- ISO/GLP/GMP compliant printing record
- Underweigh hook included
- Internal calibration
- Plastic housing

## 1.3 Capacities and Options

Table 1-1 lists the TA Plus balance capacities.

Model	Capacity	Units of Measure	Unit
TA Plus - 124	120 g	Decimal Ounce	4.2 x 0.000005 oz
		Decimal Pound	0.26 x 0.000001 lb
		Troy Ounce	3.8 x 0.000005 ozt
		Pennyweight	77 x 0.0001 dwt
		Carat	600 x 0.0005 ct
		Momme	32 x 0.00005 mom
		Grain Unit	1,800 x 0.002 GN
		Tael	3.2 x 0.000005 TL
		Tola	10 x 0.00001 to
TA Plus - 224	220 g	Decimal Ounce	7.7 x 0.000005 oz
		Decimal Pound	0.48 x 0.000001 lb
		Troy Ounce	7 x 0.000005 ozt
		Pennyweight	140 x 0.0001 dwt
		Carat	1100 x 0.0005 ct
		Momme	58 x 0.00005 mom
		Grain Unit	3,300 x 0.002 GN
		Tael	5.8 x 0.000005 TL
		Tola	18 x 0.00001 to

Table 1-1. Models and Capacities

### 1.3.1 Options/Accessories

Table 1-2 lists options and accessories available for the Rice Lake TA Plus balance.

Part No.	Description
108255	115 VAC Adapter
108256	230 VAC Adapter
108257	In-Use Cover
107398	Operation Manual
75351	WinWedge® Tal Software
66535	Null Modem Cable
119919	AbleCable, requires null modem cable PN 66535

Table 1-2. Options/Accessories



## 2.0 Installation

---

**IMPORTANT**

*Use the balance only in areas free from environmental conditions that could affect the accuracy.*

*Always adjust the level of the balance before use.*

*Calibrate the balance when it is installed or relocated.*

*After moving balance, open windshield door to allow it to adapt to the ambient temperature for stable measurement.*

*Allow five minutes after powering on for the balance to warm up.*

### 2.1 Measuring Environment Precautions

#### Temperature/Air Draft/Humidity/Atmospheric Pressure

- Keep the room temperature constant
- Avoid exposure to airflow (air conditioner, heat ducts)
- Avoid exposure to direct sun that can cause abrupt temperature changes
- Low humidity can cause static electricity, resulting in inaccurate measurements
- Avoid locations that are subject to dust

#### Vibration/Shaking

- When possible, locate balance in a room on the first floor or basement
- Rooms near a road/railroad should be avoided
- Place balance on a table/counter that is not affected by vibration
- Placing a sheet of soft cloth or paper under the balance can cause shaking

#### Gravity

- The latitude and altitude of a measuring location can affect a weight reading due to changes in gravity
- Calibrate the balance at a measuring location to account for location gravity

#### Electromagnetic Wave

- Avoid locations where strong electromagnetic wave generating objects are present
- Avoid using tables that are subject to magnetism or static electricity

### 2.2 Balance Main Unit Precautions

#### Operating Precautions

- If a dust cover is used, wipe with an anti-static agent or remove the cover
- For stability, turn on the balance 30 minutes or more and load the balance a few times with a calibration weight equivalent to the weighing capacity prior to using

#### Adjustment

- Calibrate balance periodically with an external adjustment weight or internal adjustment weight, external is more precise
- Adjustment is needed when:
  - Using the balance for the first time
  - Using the balance after a long period of non-use
  - Relocating the balance
  - A major change in temperature, humidity or atmospheric pressure has happened

#### Maintenance

- Remove any dust or liquid from the pan and/or pan base prior to operation
- Ensure that no dust or liquid enters the balance when cleaning
- Frequent cleaning of the balance is required

## 2.3 Unpack Balance

Unpack the balance and inspect the contents. Report missing or damaged components to the shipper and Rice Lake Weighing Systems immediately.

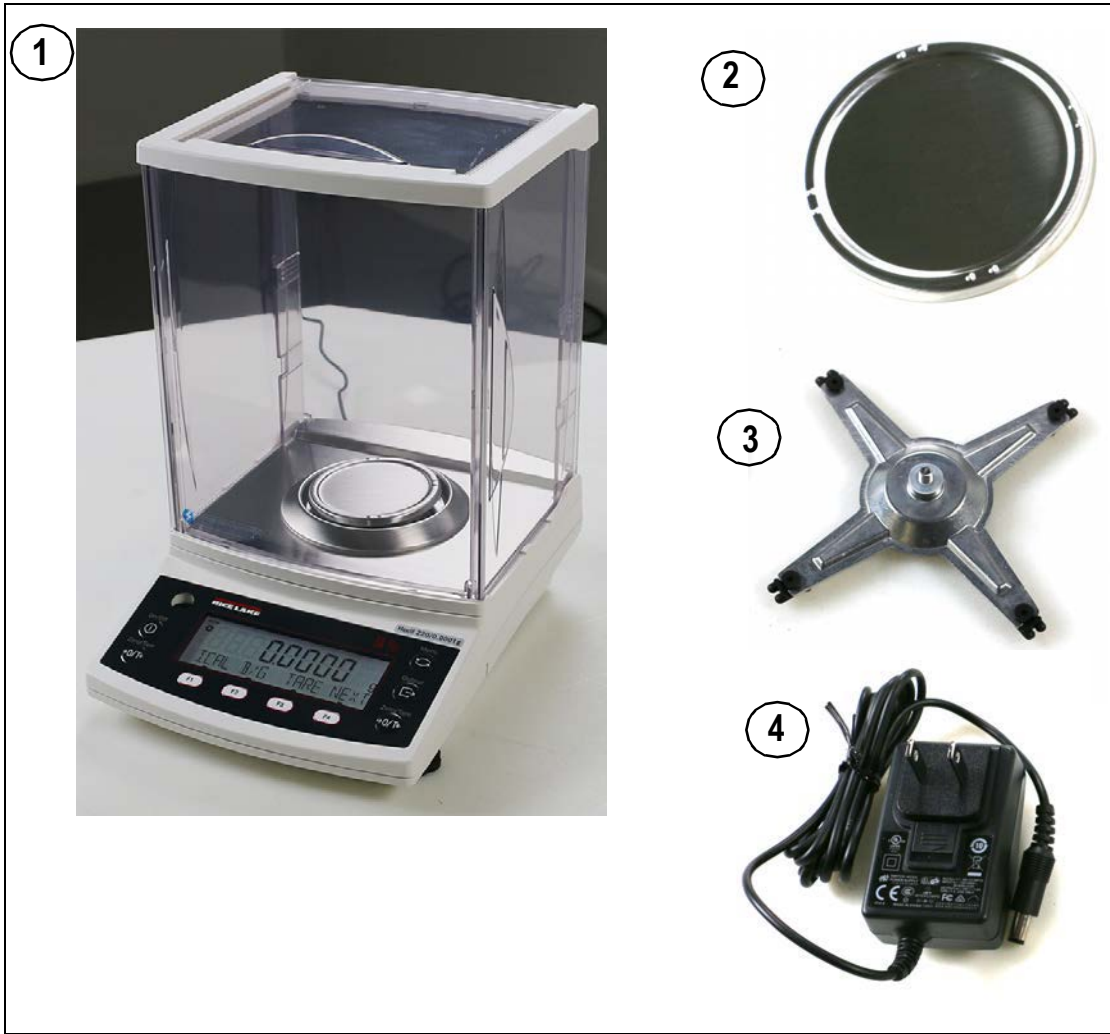

Figure 2-1. Balance Components

Item No.	Description
1	Main Unit
2	Pan
3	Pan Base
4	AC Adapter

Table 2-1. TA Plus Balance Parts

## 2.4 Leveling the Balance

Use the following steps to level the balance.

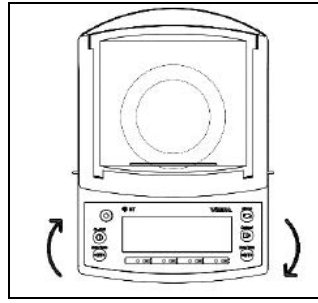

Figure 2-2. Unlock feet/adjusters

1. Turn the feet/adjusters several times as shown in [Figure 2-2](#) to unlock them.

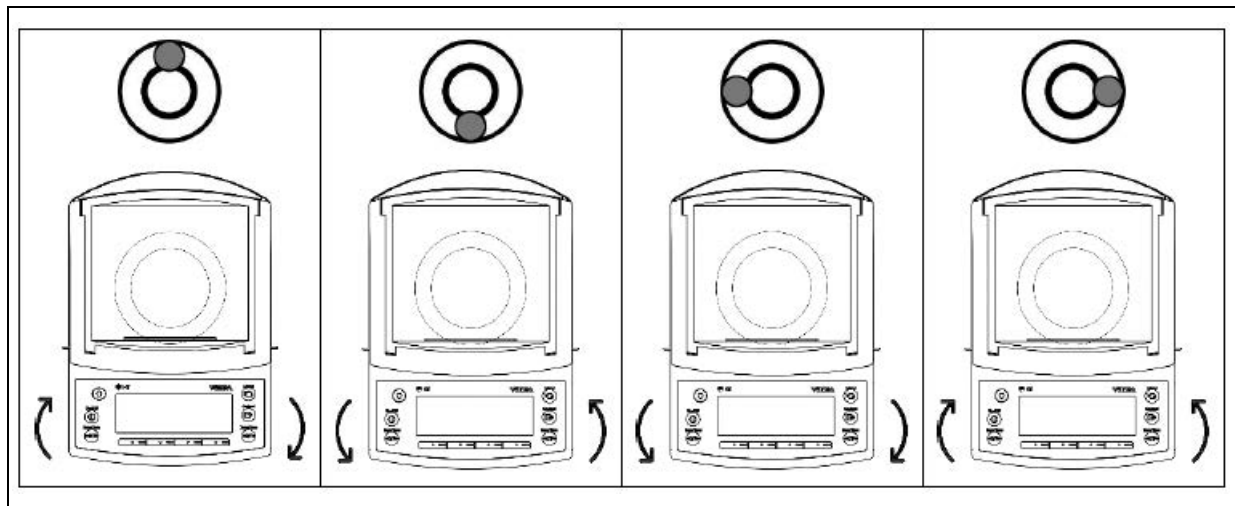

Figure 2-3. Level the Balance

2. Turn feet/adjusters until the bubble level is centered in the center circle. [Figure 2-3](#) indicates directions to turn the feet/adjusters to move the bubble in the center.

## 3.0 Operation

This section walks through using the modes of operation and the other functions used during the operation of the balance.

### 3.1 Front Panel

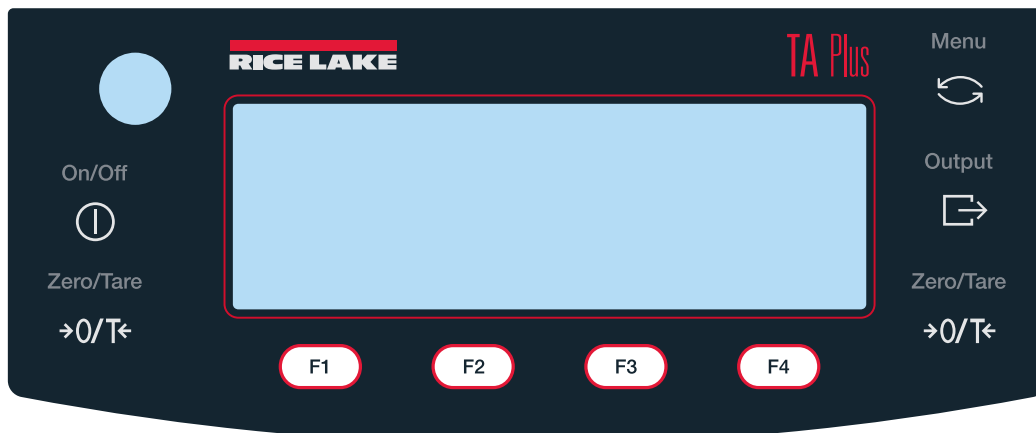

Figure 3-1. TA Plus Front Panel

Keys	Description
	Power - Press to turn the unit on; a long press to turn the unit off
	Menu - Press to enter/exit the settings menu; cancels setting value selection and returns to the measuring mode
	Output - Used for data outputting
	Zero - Zeros the balance Tare - Allows the weight of a container to be removed from the gross weight; leaving the net weight displayed.
	F1 - Select the mode, function or item; used for moving down to the menu/item selections; use for incrementing the numeric values
	F2 - Select the mode, function or item; used for moving down to the menu/item selections; use for decrementing the numeric values
	F3 - Select the mode, function or item; used for moving to the upper menu level or use for selecting the digit to change
	F4 - Select the mode, function or item; used for moving to the lower menu level; used for entering a value. Select the digit to change

Table 3-1. Keys and Descriptions

### 3.2 Annunciators

The Rice Lake TA Plus balance uses a set of LCD annunciators to provide additional information about the value being displayed on the screen.

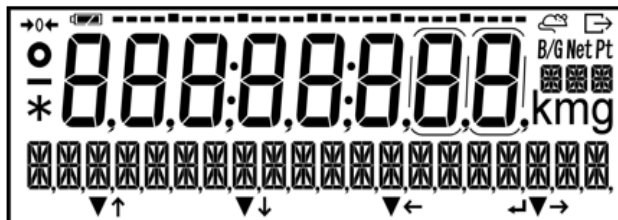

Figure 3-2. TA Plus Annunciators

LCD	Description
*	Asterisk - Lights while in standby mode; indicates that the addition is enabled and for accepting an additional load
-	Minus - Indicates that there is a negative weight value
○	Stable - Indicates that the balance is stable when displayed If this light is off, it indicates that the balance is unstable
⇨	Output - Used for data outputting
8	7 Segment String - Indicates the weight value and indicates the simplified character
B/G	Gross - Indicates that gross weight is being displayed
Net	Net - Indicates that net weight is being displayed
Pt	Preset Tare - Indicates a preset tare weight is displayed
XXXXXXXXXXXXXXXXXXXX	16 Segment String - Indicates various units
kmg	Units - Indicates the unit of value displayed; mg is not available in Legal for Trade applications
→0←	Zero point - Indicates the zero point
-----	Bar graph - Indicates the present total amount relative to the weighing capacity defined as 100%. Indicates the state of the span adjustment/calibration with internal weight

Table 3-2. LCD Annunciators

### 3.3 Precautions Related to a Specimen

#### Static Electricity

- Synthetic resin- and glass-made specimens are easily charged electrically
- Weighing electrically charged specimens makes the displayed value unstable, reducing the reproducibility of a test result
- Neutralize electrically charged specimens before measurement

#### Magnetism

- Specimens affected by magnetism weigh differently depending on the position on the pan, reducing reproducibility
- Eliminate the magnetism or place the specimens on a container/plate to protect the weighing mechanism

#### Moisture Absorption/Evaporation





- Wet or volatile specimens can cause the displayed value to continuously fluctuate due to evaporation
- Put these specimens in a container with a tight fitting lid to prevent evaporation during the weighing process

#### Specimen Temperature

- Difference in temperature between specimens and the windshield interior generates convection flow, causing errors
- If specimen temperature is excessively high or low, allow its temperature to stabilize at room temperature prior to measuring
- Ensure the windshield interior temperature is equal to room temperature prior to measuring
- Body temperature of operator affects measurement results; handle specimens with tweezers and refrain from putting hands in the windshield during operation

### 3.4 Display Navigation

Use the F-keys to navigate through the menus and enter numerical values.



-  = F1: Increments numeric values. Scrolls through menus/selections
-  = F2: Decrements numeric value. Scrolls through menus/selections
-  = F3: Select digits and returns to previous level
-  = F4: Enters the value or a level

### 3.5 Power On/Off

When balance is plugged in,  displays indicating it is in standby mode.

Press . A self-check runs, then 000000 displays.

- Do not press any buttons during the self-check
- The balance starts in the last operation mode set

Press and hold  to put the balance into standby mode (approximately 2-3 seconds).  displays.

#### 3.5.1 Balance Operation Check

Press on the weighing pan lightly to see if the weight display changes.

## 3.6 Zero-Point Adjustment

A zero-point adjustment is an adjustment of the scale's zero value with all weight removed from the scale. The scale must be stable and within the zero range to perform this.



**Note** *On Legal for Trade balances, this setting is read only, the wait time cannot be changed.*

Use the following steps to do a zero-point adjustment.

1. Ensure the weigh pan is empty.
2. Press **→0/T←**, **ZERO TARE** displays.
3. 0000000 displays after zero is complete.

The stability wait time can be set in the Applications menu in [Section 5.2 on page 29](#).

### 3.6.1 Zero-Point Adjustment Limits

The **Zero Point** limit is the threshold at which the operator can press **→0/T←** and have it zero.

#### IMPORTANT

*There is an upper and lower threshold, outside of that, the balance cannot be zeroed.*

Model	Lower Limit (g)	Upper Limit (g)
TA Plus - 124	-1.8	1.8
TA Plus - 224	-3.3	3.3

Table 3-3. Zero-Point Adjustment Limits



**Note** *Weight above 1.5% of capacity will be processed as a tare but a recalibration would be needed to adjust a zero point outside of this.*

## 3.7 Tare Value

To weigh using a container, the container weight should be subtracted from the total value. Then results displayed are the weight of the product only.



**Note** *A Tare Value is included in the total maximum capacity.*

*If a tare exceeds the zero point adjustment range (Section 3.6.1) on initial power up, the tare subtraction is executed.*

1. Place the empty container on the balance. The weight of the container displays.
2. Press **→0/T←**, **ZERO TARE** displays.
3. 0000000 displays after zero is complete.
4. Place the product to be weighed in the container. The net weight displays.
5. Remove the product and container from the balance.
6. Press **→0/T←** to remove the tare.



**Note** *Weight above 1.5% of capacity will be processed as a tare but a recalibration would be needed to adjust a zero point outside of this.*

### 3.7.1 Preset Tare

When a tare weight is already known, the tare subtraction can be configured as a **Preset Tare** parameter. Five preset tare values can be stored.

To use a preset tare:

1. Press displays.
2. Press **F1** until **3 USER INFO** displays.
3. Press **F4** and **31 PT MODE** and the current setting displays.

4. Press **F4**. The current setting begins to flash.
5. Press **F1** or **F2** to select desired preset tare number (1-5).
6. Press **F4** to save the setting.
7. Press  to return to operation display. **NET** displays in the upper right hand corner of the display.

To exit a preset tare:

1. Ensure there is no weight on the balance.
2. Press . **ZERO** flashes and display returns to Weigh Mode. **NET** is no longer displayed.



**Note** *This not only exits a preset tare, it also sets the preset tare mode back to off; disabling presets.*

### 3.7.2 Check Tare Weight Using an F-Key

If an F-key has been set to Tare, it can be used to see what the tare weight is.

1. Set an F-key to Tare.
2. With tare in place, press **F4** until **TARE** is displayed above an F-key.
3. Press the **TARE** F-key. The tare weight displays.
4. Press **F4** to return to operation mode.

### 3.7.3 Add to Product

To weigh additional products without the value of the existing product, use the following steps.

1. Place first product to be weighed on the balance.
2. Press . **ZERO TARE** displays.
3. 000000 displays after zero is complete.
4. Add additional products to the balance/container. The weight of additional product only is displayed.



### 3.8 Weigh Mode

Weigh mode is the basic mode for weighing product. Place the product on the tray, the weight will display in the units that were set in configuration.

Each mode of operation has F-key commands available.

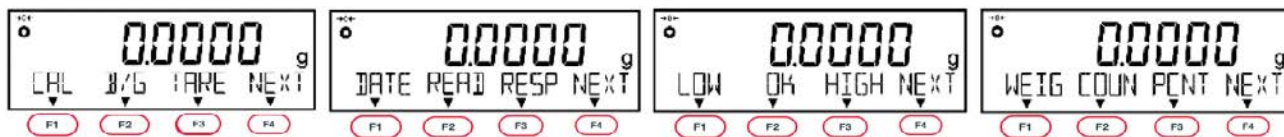

Figure 3-3. Weigh Mode F-Key Commands

F-Key Selections	Description
CAL	Use a short press to switch to the span adjustment and span test modes Use a continuous press to automatically start repeatable measurements
B/G	Displays current gross weight
TARE	Displays current tare
DATE	Displays current date
READ	Displays the current display division setting for the balance. ie: 1, 2, 5, 10
RESP	Displays the current setting for response time
LOW	Displays onW or NUM. Select onW to display current limit low, press NUM to enter a new limit low
OK	Displays onW or NUM. Select onW to display current limit OK, press NUM to enter a new limit OK
HIGH	Displays on W or NUM. Select onW to display current limit high, press NUM to enter a new limit high
WEIG	Press to display Weigh Mode
COUN	Press to display Count Mode
PCNT	Press to display Percent Mode
NEXT	Press to move between menu selections

Table 3-4. Weigh Mode F-Key Commands

### 3.9 Counting Mode

Counting mode counts the number of items placed on the balance. There are two methods to input the unit weight.

- Actual Value Setting Method: Place the specified number of samples on the balance to record the average unit weight, see [Section 3.9.1 on page 12](#)
- Numeric Value Setting Method: Input numeric value of the unit weight by key operation, see [Section 3.9.2 on page 12](#).

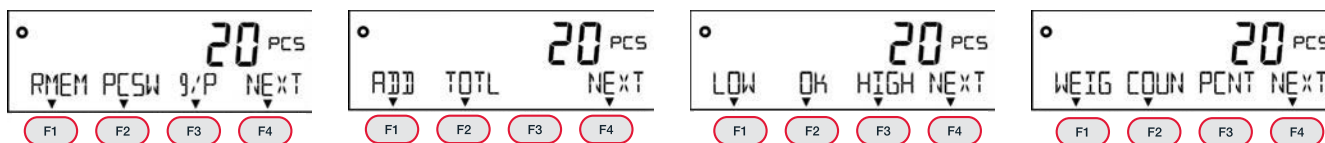

Figure 3-4. Counting Mode F-Key Commands

F-Key Selections	Description
RMEM	Change the unit weight
PCSW	Unit weight
g/P	Weight of samples/number of samples flash on display
ADD	Execute addition
TOTL	Total value
LOW	Displays onW or NUM. Select onW to display current limit low, press NUM to enter a new limit low

Table 3-5. Counting Mode F-Key Commands

F-Key Selections	Description
OK	Displays onW or NUM. Select onW to display current limit OK, press NUM to enter a new limit OK
HIGH	Displays onW or NUM. Select onW to display current limit high, press NUM to enter a new limit high
WEIG	Press to display Weigh Mode
COUN	Press to display Count Mode
PCNT	Press to display Percent Mode
NEXT	Press to move between menu selections

Table 3-5. Counting Mode F-Key Commands (Continued)

### 3.9.1 Actual Value Setting–No Change

Place the specified number of product on the balance to record the average unit weight internally.

Press **F3** or **F4** softkey to select No (change) or Yes (don't change). When there is no data recorded, this step is not available.

#### For YES (No Change):

1. Press **F4** (**YES**).
2. Press **F4** to scroll through the F-key commands until **OK** is displayed.
3. Press the **OK** F-key.
4. Place a container on the weigh pan and push **>0/T<** if needed. The zero-point adjustment or tare is set.
5. Add product for counting.

#### For NO (Change):

1. Press **F3** (**NO**). Press **F1** or **F2** to scroll through selections.
  - ON 5: 5 PCS
  - ON 10: 10 PCS
  - ON 30: 30 PCS
  - ON 50: 50 PCS
  - ON 100: 100 PCS
  - ON VAR: 1-999 PCS
  - PCSWGT: Unit weight value input
2. With the desired selection displayed, press **F4**.
3. Place a container on the weigh pan and push **>0/T<**. The zero-point adjustment or tare is set.
4. Add product for total count.

### 3.9.2 Numeric Value Setting Method

Use the key operation to input a numeric value.

1. Press **F3** or **F4** to select whether or not to use the previous data.  
When there is no data record, this step is skipped.
2. Press **F1** or **F2** to scroll through the F-key commands until **OK** is displayed. When **OK** is selected, skip to Step 5.
3. Select the unit weight value input mode by pressing **F1** or **F2** to PCSWGT.

4. Use **F1** or **F2** to enter the weight/number of the product.
5. Press **F4** to fix and the unit weight is recorded.
6. Place a container (tare) on the weighing pan and press **→0/T←**.
7. Place samples on the weighing pan and the count result is displayed.

### 3.10 Percentage Mode

The weight of a product to be weighed is shown in a percent relative to the reference weight.

There are two methods to enter the reference weight:

- Actual Value Setting Method [onW]: Where placing the reference weight on the balance is done to record the weight.
- Numeric Value Setting Method [NUM]: Inputting the numeric value of the reference weight is done by a key operation.



Figure 3-5. Percentage Mode F-Keys

F-Key Selections	Description
REF	Display reference value
TOUT	Tare value output
B/G	Gross
ADD	Executes addition
TOTAL	Total value
LOW	Displays onW or NUM. Select onW to display current limit low, press NUM to enter a new limit low
OK	Displays onW or NUM. Select onW to display current limit OK, press NUM to enter a new limit OK
HIGH	Displays onW or NUM. Select onW to display current limit high, press NUM to enter a new limit high
WEIG	Press to display Weigh Mode
COUN	Press to display Count Mode
PCNT	Press to display Percent Mode
NEXT	Press to move between menu selections

Table 3-6. Percentage Mode F-Keys Descriptions



**Note** **ADD** and **TOTL** can be used when **14 ADDITION** is set to Valid. See [Section 5.2 on page 29](#).

1. Press **↶**, then press **F4** to view the current operation mode.
2. If needed, press **F4** and use **F1** or **F2** to scroll to **PCNT**.
3. Press **F4**, then press **↶** to return to operation mode.
4. To use the previous data, press **F4** (**YES**). Skip to Step 6. (When there is no data record, this step is skipped) or  
To set the percent, press **F3** (**NO**).

- Press **F3** or **F4** to set one of the following:
  - Actual value (**onW**): Placing the reference weight on the balance and press **F4** (**OK**)
  - Numeric value (**NUM**): Use **F1** or **F2** to enter the reference weight and press **F4** (**OK**)
- Weigh the product, The ratio of the weight of the product to the reference weight is displayed in percent.

### 3.11 Multiplied By a Coefficient Mode

Measured weight is multiplied by the preset coefficient. This mode is not available in Legal for Trade units.

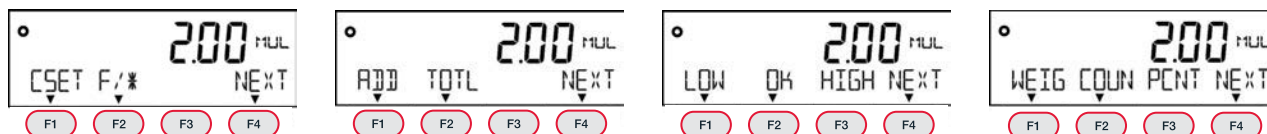

Figure 3-6. Coefficient Mode F-Keys

F-Key Selections	Description
CSET	Set the Coefficient value <ul style="list-style-type: none"> <li><b>NO</b>: Allows the change of the current coefficient</li> <li><b>YES</b>: Accept the currently set coefficient</li> </ul>
F/*	Toggles between MUL and g
ADD	Executes addition
TOTAL	Displays total value
LOW	Displays onW or NUM. Select onW to display current limit low, press NUM to enter a new limit low
OK	Displays onW or NUM. Select onW to display current limit OK, press NUM to enter a new limit OK
HIGH	Displays onW or NUM. Select onW to display current limit high, press NUM to enter a new limit high
WEIG	Press to display Weigh Mode
COUN	Press to display Count Mode
PCNT	Press to display Percent Mode
NEXT	Press to move between menu selections

Table 3-7. Coefficient Mode F-Key Descriptions



**Note** **ADD** and **TOTL** can be used when **14 ADDITION** is set to valid. See [Section 5.2](#) on page 29.

- Press . displays.
- Press **F2** until **Admin/Adjust** appears.
- Press , then press **F4**. The current operation mode displays.
- If needed, press **F4**. The currently displayed mode flashes.
- Use **F1** or **F2** to scroll to **MULT**.
- Press **F4**, then press to return to operation mode.
- To use the existing coefficient value, press **F4** (**YES**). (When there is no data record, this step is skipped.) or Press **F3** (**NO**) to set the coefficient value.
- Weigh the product, the weight is multiplied by the coefficient and the result displays.



**Note** The Coefficient can be changed at anytime using the **CSET F-key**.

### 3.12 Specific Gravity Mode

In the Specific Gravity Mode, the ratio of the density of a substance to the density of water at its densest (39° F for liquids) is calculated.

#### 3.12.1 Menus Available in Operation Mode

Use F-keys to select and scroll through menu items.



Figure 3-7. Specific Gravity Mode (Solid)



Figure 3-8. Specific Gravity Mode (Liquid)

F-Key Selections	Descriptions
RSET	Select the liquid <ul style="list-style-type: none"> <li>• OTHER: Any liquid other than water</li> <li>• H2O: Using water</li> </ul>
WAIR	Weight in air displays
WLIQ	Weight in liquid displays
WEIG	Press to display Weigh Mode
COUN	Press to display Count Mode
PCNT	Press to display Percent Mode
NEXT	Press to move between menu selections

Table 3-8. Specific Gravity Mode F-Key Descriptions

#### 3.12.2 Materials Required in Specific Gravity Mode





Materials needed to measure a specific gravity include:

- Water tank
- Hanging string or wire
- Basket for placing the sample
- Thermometer

#### 3.12.3 Prepare Equipment to Measure Specific Gravity



1. Input the water temperature or the specific gravity of the reference liquid.
2. Measure the sample weight in the air.
3. Compensate the buoyancy acting on the basket.
4. Measure the sample weight in the liquid.
5. The specific gravity of the sample is displayed.

### 3.12.4 Measure the Specific Gravity Mode

1. Press , then press **F4**. The current operation mode displays.
2. If needed, press **F4**. The currently displayed mode flashes.
3. Use **F1** or **F2** to scroll to **SPGR**.
4. Press **F4**, then press  to return to operation mode.
5. Select the reference liquid by pressing **F3** or **F4**;
  - OTHER: Liquid other than water
  - H2O: Water
6. Enter the specific gravity of the reference liquid and press **F4** to save.
7. Set the net/basket on the balance and press .
8. Add material/liquid to the net/basket to measure the weight.
9. Press **F4** to save.
10. Remove the material/liquid on the net/basket and press .
11. Lower the net/basket into the liquid.
12. Press  to compensate the buoyancy acting on the net/basket.
13. Put the material/liquid on the basket into the liquid and press **F4** to save. The specific gravity of the specimen is automatically calculated and displayed.

### 3.13 Unit Setting

There are many units types available. In Legal for Trade balances, only **g** and **ct** are available. See [Section 5.2.2 on page 31](#) for more information and a complete list of available units.

1. Press .  displays.
2. Press **F4**. **11 MODE** and the current operation mode displays.
3. Press **F1** or **F2** to scroll to **UNIT**.
4. Press **F4** to change the display unit.
5. Press **F1** or **F2** to scroll to the desired unit. See [Table 5-2 on page 31](#).
6. Press **F4** to save the operation mode.
7. Press  to return to operation display.

### 3.14 Comparator Function

The Comparator Function is used to preset threshold values (limits) and determine if a measured value is within the preset range. This function can be used in Weigh mode, Percentage mode, Counting mode and Multiplied by Coefficient mode.

#### How to Perform Discrimination

Set the lower and the upper limits and whether the weight of a specimen to be weighed is **LOW** (lower than the lower limit), **OK** (appropriate) or **HIGH** (higher than the upper limit).

For setup information, refer to [Section 5.2.3 on page 32](#).

Discrimination	Single point setting (lower limit)	Single point setting (upper limit)	Two-point setting (upper and lower limits)
Over the upper limit	< OK > Blinking	< HIGH > Blinking	< HIGH > Blinking
Appropriate amount	< OK > Blinking	< OK > Blinking	< OK > Blinking
Below the lower limit	< LOW > Blinking	< OK > Blinking	< LOW > Blinking

Table 3-9. Messages

The discrimination is performed according to the following criteria:

**Absolute value:** The discrimination is performed based on the upper and lower limit values that have been set in advance.

**Relative value:** A reference numeric value is set in advance, and the discrimination is performed based on the range defined by the upper and lower limit values that have been set for the reference numeric value.

Example:

- Two-point (upper and lower limits) setting
- Reference value = 1000.00g
- Lower limit value = 900.00 g, Upper limit value = 1200.00 g

Discrimination Method	Reference Value	Lower Limit Value	Upper Limit Value
	1000.00 g	900.00 g	1200.00 g
Absolute value		900.00 g	1200.00 g
Relative value	1000.00 g	-100.00 g	200.00 g











Table 3-10. Example

### 3.15 Addition Function

The Addition Function is used to weigh several specimens in sequence and indicate the total value. The addition function can be used in Percentage Mode, Counting Mode and Multiply Mode.

The addition function includes two ways of calculating method.

- Addition accumulating: specimens are weighed, removed and new specimens weighed
- Net adding function: specimens are weighed, then more specimens added without removing previous

1. Press .  displays.
2. Press . **11 MODE** and the current operation mode displays.
3. Press  or  to scroll to **ADDITION**.
4. Press  to enter the menu. **ACTIVATE** displays with current setting.
5. Press . The current setting begins to flash.
6. Press  or  to select desired setting.
7. Press  to save the setting.

8. Press **F1** or **F2** to scroll to **OPERATION**.
9. Press **F4**. The current setting begins to flash.
10. Press **F1** or **F2** to select desired setting.
11. Press **F4** to save the setting.
12. Press **F1** or **F2** to scroll to **DIRECTION**.
13. Press **F4**. The current setting begins to flash.
14. Press **F1** or **F2** to select desired setting.
15. Press **F4** to save the setting.
16. Press  to return to operation display.

### 3.15.1 Plus Side Addition

Set ADD to **F1** and TOTL to **F2** for this function. See [Section 4.7.2 on page 40](#).

1. Place a specimen to be weighed on the balance. Wait for **\*** to display.
2. Press **F1**. The weighed value is stored and **SUM TOTAL** displays momentarily.

#### For addition accumulating

1. Remove the first specimen and wait for 0.00 to display.
2. Place the next specimen on the balance. Wait for **\*** to display.
3. Press **F1**. The weighed value is stored and **SUM TOTAL** displays momentarily.
4. Repeat this procedure until all additions have been completed.

#### For net addition

1. Perform Steps 1-2 under [Section 3.15.1](#).
2. Without removing the previous specimen, add the next specimen to be weighed.
3. Once **\*** displays, press **F1**. **SUM TOTAL** displays.
4. The weight is displayed, followed by an automatic tare. Repeat this procedure until all additions have been completed.

### 3.15.2 Weighing with Minus Side Addition

Set ADD to **F1** and TOTL to **F2** for this function. See [Section 4.7.2 on page 40](#).

1. Place a first specimen to be weighed, **\*** displays.
2. Press , **0.00** displays.

#### For Addition Accumulating

1. Perform Steps 1-2 in [Section 3.15.1](#).
2. Remove the specimen, **\*** displays.
3. Press **F1**. The weighed value is stored and **SUM TOTAL** displays momentarily.
4. Repeat this procedure until all additions have been completed.



### For Net Addition

1. Perform steps 1-2 under [Section 3.15.1 on page 18](#).
2. Add a specimen to be weighed.
3. Once ✱ displays, press **F1**. **SUM TOTAL** displays momentarily.
4. The weight is displayed, followed by an automatic tare. Repeat this procedure until all additions have been completed.

### 3.15.3 View/Delete Total Value

Press **F2**, the total value displays.

Press **F3**, the total value is deleted.

## 3.16 Tare-Subtraction Reminder Function



If the Tare-Subtraction Reminder is activated, **PUSH TARE** displays when a container is placed on the balance.

*If the Zero-Point-Adjustment Reminder is activated at the same time, it has priority.*

There are two modes in the Tare-Subtraction Reminder function:

- **T Reminder 1** indicates the weight display is over the zero-point-adjustment range
- **T Reminder 2** indicates the weight display is over the zero-point-adjustment range before tare subtraction, and the net display is negative after tare subtraction

### 3.16.1 Set Tare-Subtraction Reminder Function



1. Press .  displays.
2. Press **F4**. **11 MODE** and the current operation mode displays.
3. Press **F1** or **F2** to scroll to **T REMINDER**.
4. Press **F4**. The current setting begins to flash.
5. Press **F1** or **F2** to select desired setting.
6. Press **F4** to save the setting.
7. Press  to return to operation display.





## 3.17 Zero-Point-Adjustment Reminder Function

If the Zero-Point-Adjustment Reminder is activated, **PUSH ZERO** is displayed if the load returns to within the zero point adjustment range after the load was over the range.

Place the samples on the weighing pan. When the samples are removed, **PUSH ZERO** displays. Press  and 0.00 displays

### 3.17.1 Set Zero-Point-Adjustment Reminder Function

1. Press .  displays.
2. Press **F4**. **11 MODE** and the current operation mode displays.
3. Press **F1** or **F2** to scroll to **Z REMINDER**.











4. Press . The current setting begins to flash.
5. Press  or  to select desired setting.
6. Press  to save the setting.
7. Press  to return to operation display.

### 3.18 Stabilization Wait Function

The Stabilization Wait Function indicates when the weighed value displays after a zero-point adjustment or tare, either after or before the weighed value stabilizes.











- OFF: function is not available
- ON: balance always waits for stabilization before displaying weighed value after the zero-point adjustment or tare

#### 3.18.1 Set Stabilization Wait Function

1. Press .  displays.
2. Press . **11 MODE** and the current operation mode displays.
3. Press  or  to scroll to **WT STABLE**.
4. Press . The current setting begins to flash.
5. Press  or  to select desired setting.
6. Press  to save the setting.
7. Press  to return to operation display.

### 3.19 Bar Graph Display

The bar graph is displayed above the weight display when set to on.











1. Press .  displays.
2. Press . **11 MODE** and the current operation mode displays.
3. Press  or  to scroll to **BARGRAPH**.
4. Press . The current setting begins to flash.
5. Press  or  to select **ON** or **OFF**.
6. Press  to save the setting.
7. Press  to return to operation display.

## 3.20 Back Light Display

The back light can be set to **3MIN**, **5MIN**, **10MIN**, **30MIN**, **ON** or **OFF**. The back light will be on for the set number of minutes or always on if **ON** is selected. If **OFF** is selected, there is no back light.

This function does not work under if:

- A menu is displayed
- A specimen is placed on the weighing pan and the display is not stable











1. Press .  displays.
2. Press . **11 MODE** and the current operation mode displays.
3. Press  or  to scroll to **BACKLIGHT**.
4. Press . The current setting begins to flash.
5. Press  or  to select desired time.
6. Press  to save the setting.
7. Press  to return to operation display.

## 3.21 Auto Off Function

The Auto Off function is used to set an amount of time for the balance to remain on with no activity. Once the set time is reached the balance will automatically turn off. It can be set to **3MIN**, **5MIN**, **10MIN**, **30MIN** or **OFF**. If set to **OFF**, the balance remains on indefinitely.

This function does not work under if:











- A menu is displayed
- A specimen is on the weigh pan and the display is not stable

1. Press .  displays.
2. Press . **11 MODE** and the current operation mode displays.
3. Press  or  to scroll to **BACKLIGHT**.
4. Press . The current setting begins to flash.
5. Press  or  to select desired time.
6. Press  to save the setting.
7. Press  to return to operation display.

## 3.22 Simple Self Counting System (SCS) Method



1. Put a set number of samples in place.
2. Put up to two times the set number of additional samples in place. The balance will automatically update the average sample weight.
3. Repeating this allows accurate counting.

### 3.22.1 Set SCS Method

1. Press .  displays.
2. Press . **11 MODE** and the current operation mode displays.
3. Press  or  to scroll to **SIMPLE SCS**.
4. Press . The current setting begins to flash.
5. Press  or  to select ON or OFF
6. Press  to save the setting.
7. Press  to return to operation display.

## 4.0 Span Test and Calibration

Use the following steps to access the span adjustment/test, calibration and other controlling and adjustment functions.

1. Press .  displays.
2. Press  until **Admin/Adjust** appears.

Individual key presses can then be used for specific functions as shown in the [Figure 4-1](#) flow chart. Refer to the following sections to complete the specific function.

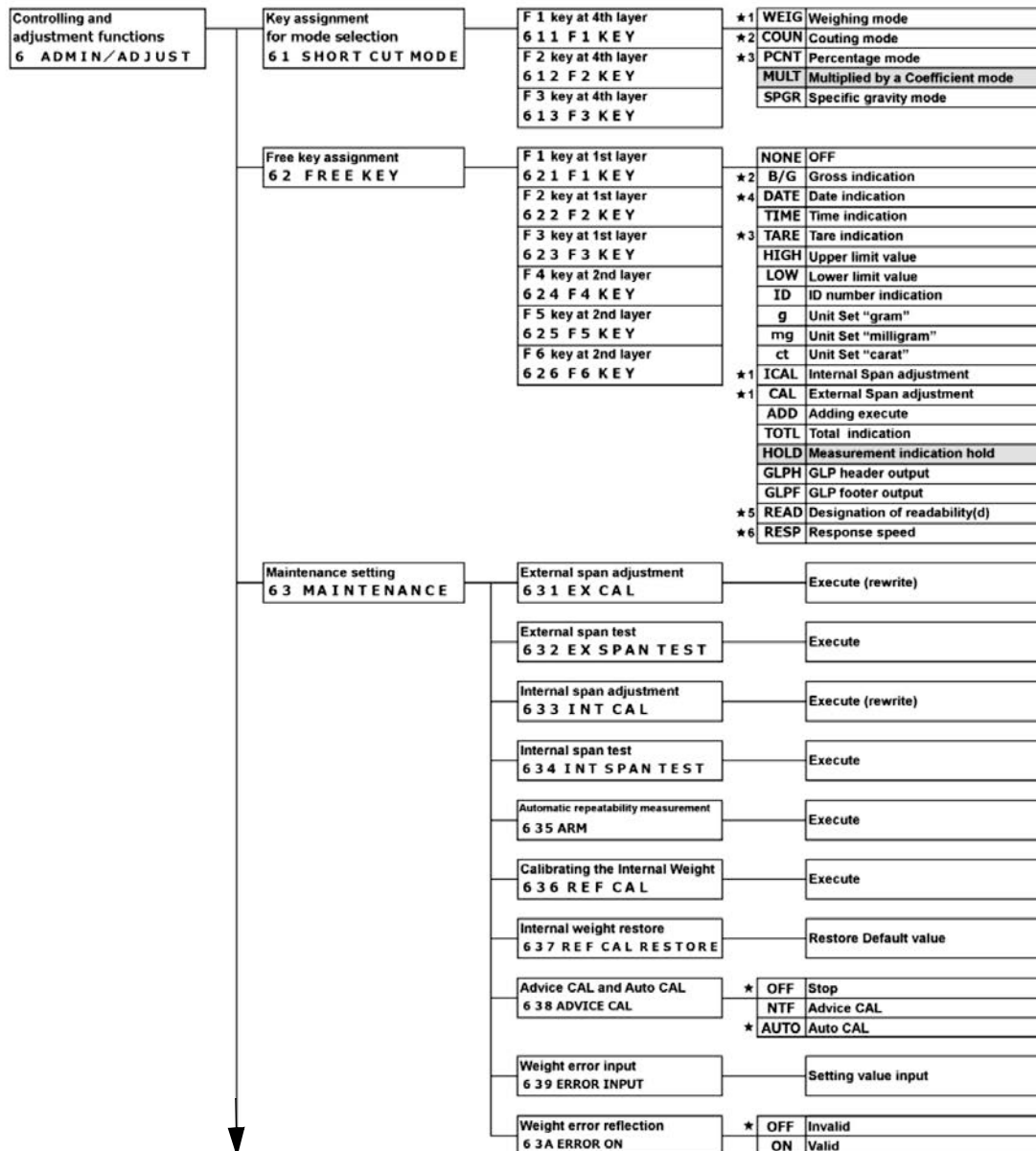

Figure 4-1. Span Adjustment Menu

## 4.1 Span Adjustment

Because an electronic balance is affected by the acceleration of gravity, a span adjustment is needed at every weighing location. The span adjustment is also needed when using the balance for a long period of time and when an accurate indication doesn't display any longer.

### 4.1.1 Span Adjustment with External Weight

3. Press **F4** to change the mode.
4. Press **F2** to scroll to **Maintenance**.
5. Press **F4** to scroll to **631 EX CAL**.
6. Press **F4** to start the span adjustment. **Cal Started** displays.
7. Press **F1** or **F2** to select the minimum interval for rounding the weight of the external weight.

Interval	Rounding Weight
1	0.0001 g
2	0.0002 g
5	0.0005 g
10	0.001 g

Table 4-1. External Weight

8. Press **F2** to set the interval.
9. Press **F2** to select a weight used for span adjustment.



**Note** An error of UC shown on the display may indicate the use of a weight less than the weighing capacity was used.

10. Press **F4** to initiate the zero span adjustment. **On 0** and **on processing** is displayed followed by **on F**.
11. Place the weight in the center of the weighing pan and on completion of the span adjustment, the display changes to **631 EX CAL**.
12. Remove weight from the weighing pan and press .

### 4.1.2 Span Test with External Weight



**Note** Make sure to use the external weight that is equal to the weighing capacity of the balance model.

1. Press **F4** to change the mode.
2. Press **F2** to scroll to **Maintenance**.
3. Press **F4** to scroll to **632 EX SPAN TEST**.
4. Press **F4** to start the span test. **on 0** and **processing** displays. On completion of the zero point, the display changes to **On FS**.
5. Place a weight in the center of the weighing pan. **On FS** displays then changes to **INSTRUMENTAL ER**.
6. Press **F4** and **632 EX SPAN TEST** displays.
7. Remove weight from the weighing pan and press .

### 4.1.3 Semi-Automatic Span Adjustment with Internal Weights

 **Note** Do not power off the balance while this function is operating.

1. Press **F4** to change the mode.
2. Press **F2** to scroll to **Maintenance**.
3. Press **F4** to scroll to **633 INT CAL**.
4. Press **F4** to start the span adjustment. **Cal Started** displays.
5. The span adjustment starts and **CH 0**, **CH FS** and **633 INT CAL** is displayed in that order.
6. Press  to exit.

## 4.2 Span Test

The span test is used to check the amount of offset in the span of the balance with respect to the reference weight. Performing this function will not calibrate the balance.

 **Note** To adjust the span or perform a span test, wait at least five minutes after the power is turned on.  
Do not power off the TA Plus balance while this function is operating.

### 4.2.1 Span Test with Internal Weights

1. Press **F4** to change the mode.
2. Press **F2** to scroll to Maintenance.
3. Press **F4** to scroll to **634 INT SPAN TEST**.
4. Press **F4** to start the span adjustment. **Span Test Started** displays.
5. The span test starts and **CH 0**, **CH FS** and **INSTRUMENTAL ER** is displayed in that order.
6. Press **F4**. **634 INT SPAN TEST** displays.
7. Press  to exit the setting menu.

### 4.2.2 Automatic Repeatability Measurement (ARM)

This function is used to calculate a standard deviation by loading and unloading the built in weight 10 times.

1. Press **F4** to change the mode.
2. Press **F2** to scroll to **Maintenance**.
3. Press **F4** to scroll to **635 ARM**.
4. Press **F4** to start the automatic readability measurement.
5. The test starts and the display and **ArM**, **Cnt 1**, **Cnt 2** through **Cnt 10**, then the standard deviation displays.
6. Press **F4** and **635 ARM** displays.
7. Press  to exit the setting menu.

### 4.2.3 Calibrating the Internal Weight

This function is used to calibrate the internal weight using an external weight.



**Note** To calibrate more accurately use a weight that is equivalent to the weighing capacity.

1. Press **F4** to change the mode.
2. Press **F2** to scroll to **Maintenance**.
3. Press **F4** **636 REF CAL** displays.
4. Press **F4** to start the span test. **on 0** and **processing** displays. On completion of the zero point, the display changes to **On FS**.
5. Place a weight in the center of the weighing pan and **on FS** displays.
6. **on 0** displays upon completion of the span adjustment.
7. Remove weight from the balance and a blinking **on 0** displays followed by **Ch 0** and **Ch FS**.
8. Upon completion of the calibrating of the internal weight, **636 REF CAL** displays.
9. Press  to exit the setting menu.

### 4.2.4 Restore the Internal Weight Calibration Value to Default

1. Press **F4** to change the mode.
2. Press **F2** to scroll to **Maintenance**.
3. Press **F4** **637 REF CAL RESTORE** displays. The internal weight calibration value is restored to the default factory settings.
4. Press **F4** and **637 REF RESTORE** displays.
5. Press  to exit the setting menu.

### 4.2.5 Advice CAL and Automatic Span Adjustment

The TA Plus balance generates an alarm when calibration is needed.

1. Press **F4** to change the mode.
2. Press **F2** to scroll to **Maintenance**.
3. Press **F4** **638 ADVICE CAL** displays.



4. Press **F2** to select the **NTF** setting. Options available are:

OFF	Disable
NTF	Advice CAL
AUTO	Auto CAL

Table 4-2. Alarm Calibration Settings

5. Press **F4** to change the mode.
6. Press  to exit the setting menu.
7. A message appears (**PLEASE EXEC CAL RET**) when time passed since a power up, a last span adjustment or temperature pressure changed.
8. Press **F4** to shift to the measuring mode.
9. Start a span adjustment with external weights ([Section 4.1.1 on page 24](#)) or a semi-automatic span adjustment with internal weights ([Section 4.1.3 on page 25](#)).

#### 4.2.6 Weight Error Input

The error of the external reference weight used for span adjustment/span test can be inputted.

1. Press **F4** to change the mode.
2. Press **F2** to scroll to **Maintenance**.
3. Press **F4** to scroll to **639 ERROR INPUT**.
4. Input the unit weight by pressing Press **F1** through **F3**.
5. Press **F4** to save the selection.
6. Press **F2** and **63A ERROR ON** displays.
7. Press **F4** then **F2** to select **ON**.
8. Press **F4** to save the selection.
9. Press  to exit the setting menu.
10. Perform and span adjustment/test weigh external weights ([Section 4.1.1 on page 24](#)).

#### 4.2.7 Weight Error Reflection

The error of the external reference weight used for span adjustment/span test can be inputted.

1. Press **F4** to change the mode.
2. Press **F2** to scroll to Maintenance.
3. Press **F4** to scroll to **63A ERROR INPUT**.
4. Input the unit weight by pressing Press **F1** through **F3**.
5. Press **F4** to save the selection.



## 5.2 Application Menu

The Application Menu is used to set operational parameters.

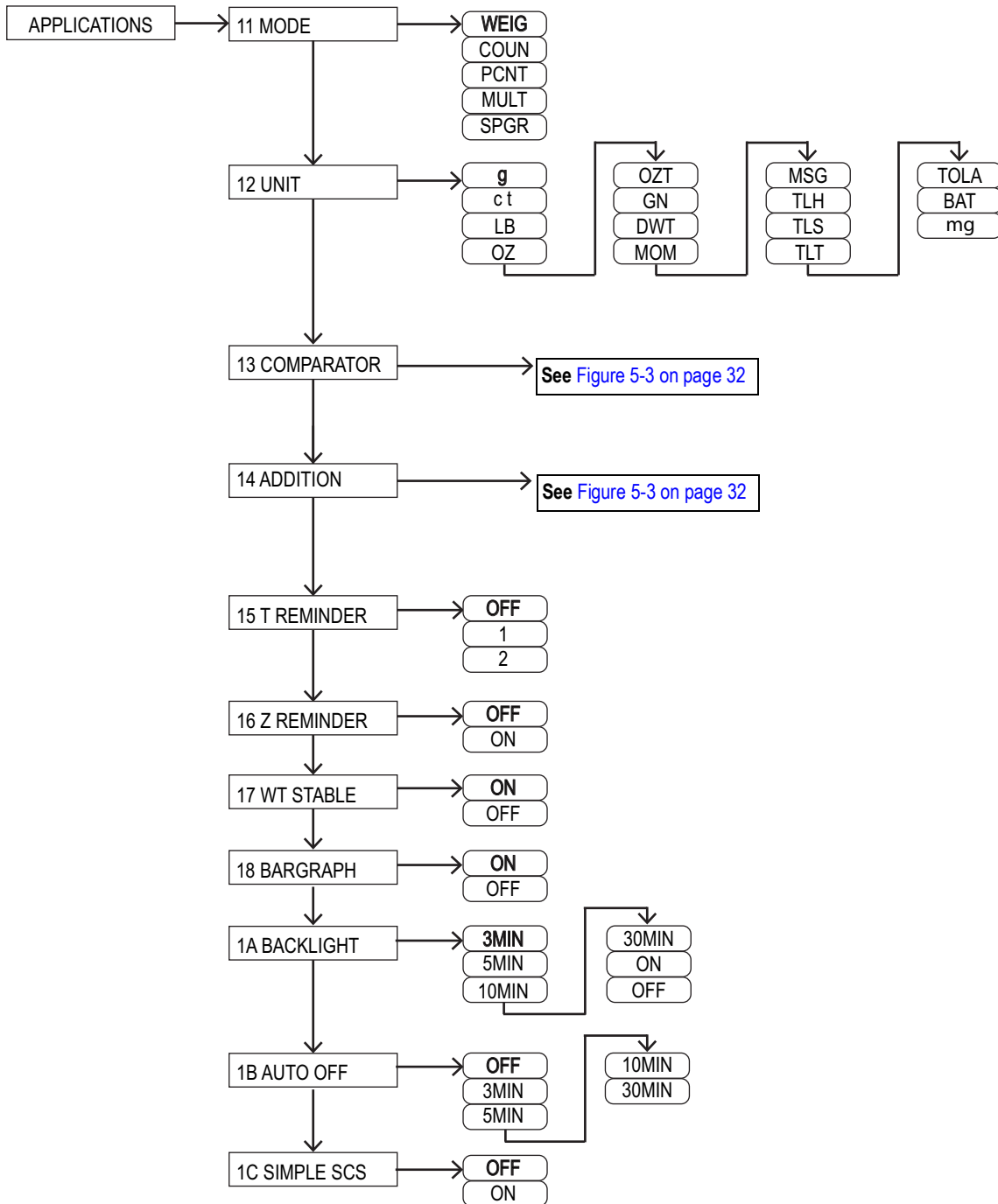

Figure 5-2. Applications Menu Layout









Menu	Parameters	Description
11 MODE	Select operation mode, see <a href="#">Section 5.2.1 on page 30</a>	
	WEIG	Weigh Mode
	COUN	Counting Mode
	PCNT	Percentage Mode
	MULT	Multiplied by a Coefficient
	SPGR	Specific Gravity Mode
12 UNIT	Set the unit for weight, see <a href="#">Section 5.2.2 on page 31</a>	
	g	Gram
	c t	Carat
	LB	Pound
	OZ	Ounce
	OZT	Troy Ounce
	GN	Grain
	DWT	Pennyweight
	MOM	Momme
	MSG	Mesghal
	TLH	Tael (Hong Kong)
	TLS	Tael (Singapore, Malaysia)
	TLT	Tael (Taiwan)
	TOLA	Tola
	BAT	Baht
	mg	Milligram
13 COMPARA-TOR	Comparator Function; see <a href="#">Figure 5-3 on page 32</a>	
14 ADDITION	Adding Function; see <a href="#">Section 5.2.4 on page 33</a>	
15 T REMINDER	Tare on Reminder	
	OFF	Disabled
	1	Activate the MODE 1
	2	Activate the MODE 2

Menu	Parameters	Description
16 Z REMINDER	Zero on Reminder	
	OFF	Disabled
	ON	Enabled
17 WT STABLE	Stability Waiting	
	ON	Enabled
	OFF	Disabled
18 BARGRAPH	Bar Graph Indication	
	ON	Enabled
	OFF	Disabled
1A BACKLIGHT	Back Light timer, time the backlight remains on	
	3MIN	3 minutes
	5MIN	5 minutes
	10MIN	10 minutes
	30MIN	30 minutes
	ON	Always on
	OFF	Disabled
1A AUTO OFF	Auto Power Off, time the balance is inactive before it powers off	
	OFF	Disabled
	3MIN	3 minutes
	5MIN	5 minutes
	10MIN	10 minutes
	30MIN	30 minutes
	1C SIMPLE SCS	Simplified SCS
OFF	Disabled	
ON	Enabled	

Table 5-1. Applications Menu Parameters

### 5.2.1 Operation Modes

Set the balance to desired operation mode.

- Press .  displays.
- Press . **11 MODE** and the current operation mode displays.
- Press  to change the mode if needed.
- Press  or  to scroll to the desired mode of operation.
- Press  to save the operation mode.
- Press  to return to operation display.











## 5.2.2 Units

Use [Table 5-2](#) when setting the display units. Not all units are available in Legal for Trade balances.

Display	Unit	Conversion coefficient	Model Weighing Capacity and Readability by Unit	
			TA Plus - 124	TA Plus - 224
g	gram	1.00000000E+00	120 0.0001	220 0.001
ct	carat	5.00000000E+00	600 0.0005	1100 0.01
LB	pound	2.20462260E-03	0.26 0.000001	0.48 0.00001
OZ	ounce	3.52739610E-02	4.2 0.000005	7.7 0.0001
OZT	troy ounce	3.21507460E-02	3.8 0.000005	7 0.0001
GN	grain	1.54323580E+01	1800 0.002	3300 0.1
DWT	pennyweight	6.43014930E-01	77 0.0001	140 0.001
MOM	momme	2.66666670E-01	32 0.00005	58 0.001
MSG	mesghal	2.16999761E-01	26 0.00005	47 0.001
TLH	Hong Kong tael	2.67172510E-02	3.2 0.000005	5.8 0.0001
TLS	Singapore, Malaysia tael	2.64554710E-02	3.1 0.000005	5.8 0.0001
TLT	Taiwan tael	2.66666670E-02	3.2 0.000005	5.8 0.0001
TOLA	tola	8.57353240E-02	10 0.0001	18 0.0001
BAT	baht	6.59630607E-02	7.9 0.00001	14 0.0001
mg	milligram	1.00000000E+03	120000 0.1	220000 1

Table 5-2. Unit Conversion Weighing Capacity and Readability

To set the desired unit displayed:

1. Press .  displays.
2. Press . **11 MODE** and the current operation mode displays.
3. Press  or  to scroll to **UNIT**.
4. Press  to change the display unit.
5. Press  or  to scroll to the desired unit.
6. Press  to save the operation mode.
7. Press  to return to operation display.

### 5.2.3 Comparator Menu

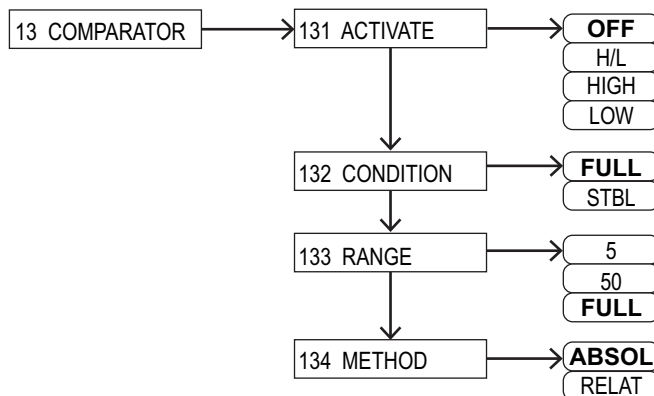





Figure 5-3. Applications Comparator Menu Layout

Menu	Parameters	Description
131 ACTIVATE	Activates the comparator function	
	OFF	Disabled
	H/L	Valid upper and lower limits
	HIGH	Valid upper limit
	LOW	Valid lower limit
132 CONDITION	Discriminant condition	
	FULL	Always
	STBL	Only at stable times
133 RANGE	Discriminant range	
	5	+5 (e/d) or more
	50	+50 (e/d) or more
	FULL	Entire area
134 METHOD	Discriminant method	
	ABSOL	Absolute value method
	RELAT	Relative value method

Table 5-3. Applications Comparator Parameters

See Section 3.14 on page 17 for user information.

- Press .  displays.
- Press **F4**. **11 MODE** and the current operation mode displays.
- Press **F1** or **F2** to scroll to **COMPARATOR**.
- Press **F4** to enter the menu. **ACTIVATE** displays with current setting.
- Press **F4**. The current setting begins to flash.
- Press **F1** or **F1** to select desired setting (**OFF**, **H/L**, **HIGH** or **LOW**).
- Press **F4** to save the setting.
- Press **F1** or **F2** to scroll to **CONDITION**.
- Press **F4**. The current setting begins to flash.

10. Press **F1** or **F2** to select desired setting.
11. Press **F4** to save the setting.
12. Press **F1** or **F2** to scroll to **RANGE**.
13. Press **F4**. The current setting begins to flash.
14. Press **F1** or **F2** to select desired setting.
15. Press **F4** to save the setting.
16. Press **F1** or **F2** to scroll to **METHOD**.
17. Press **F4**. The current setting begins to flash.
18. Press **F1** or **F2** to select desired setting.
19. Press **F4** to save the setting.
20. Press  to return to operation display.

### 5.2.4 Addition

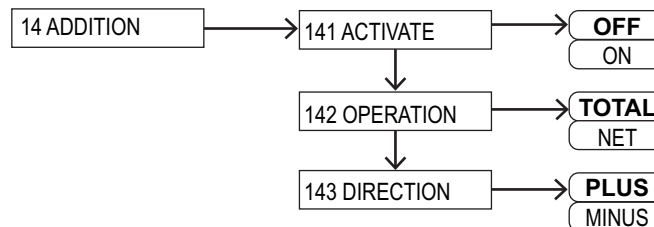





Figure 5-4. Applications Addition Menu Layout

Menu	Parameters	Description
131 ACTIVATE	Activates the addition function	
	OFF	Disabled
	ON	Enabled
132 OPERATION	Adding operation	
	TOTAL	Addition accumulated
	NET	Net addition
133 DIRECTION	Adding direction	
	PLUS	Plus side addition
	MINUS	Minus side addition

Table 5-4. Applications Addition Parameters

1. Press .  displays.
2. Press **F4**. **11 MODE** and the current operation mode displays.
3. Press **F1** or **F2** to scroll to **ADDITION**.
4. Press **F4** to enter the menu. **ACTIVATE** displays with current setting.

5. Press **F4**. The current setting begins to flash.
6. Press **F1** or **F2** to select desired setting.
7. Press **F4** to save the setting.
8. Press **F1** or **F2** to scroll to **OPERATION**.
9. Press **F4**. The current setting begins to flash.
10. Press **F1** or **F2** to select desired setting.
11. Press **F4** to save the setting.
12. Press **F1** or **F2** to scroll to **DIRECTION**.
13. Press **F4**. The current setting begins to flash.
14. Press **F1** or **F2** to select desired setting.
15. Press **F4** to save the setting.
16. Press  to return to operation display.

### 5.3 Performance Menu

Set the balance display stability, response and Zero Track speed.

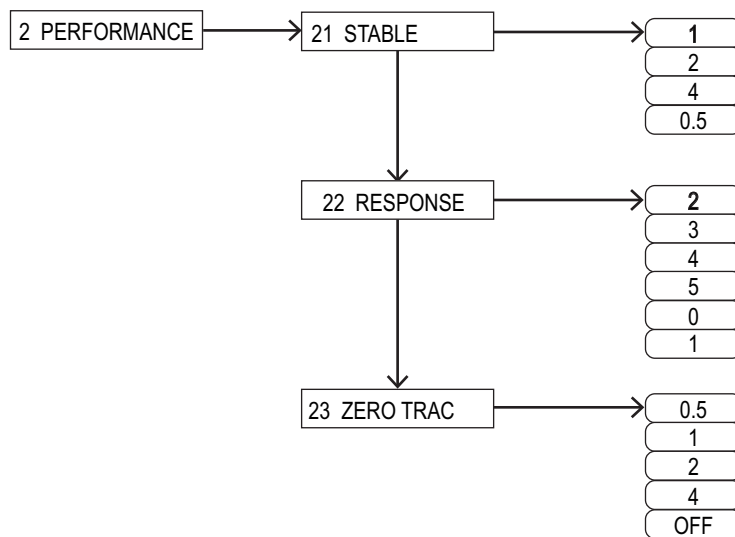

Figure 5-5. Performance Menu Layout



Menu	Parameters	Description
21 STABLE	Stability discrimination width	
	1	1d
	2	2d
	4	4d
22 RESPONSE	Response speed	
	1	Sensitive mode
	2	Fast
	3	Normal
	4	Slow
23 ZERO TRAC	Zero Tracking	
	0.5	0.5d
	1	1d
	2	2d
	4	4d
	OFF	Invalid











Table 5-5. Performance Menu Parameters

### 5.3.1 Stability

When the larger numeric value is set in this setting menu, the laxer stability judgment is applied and the balance displays **O** in more unstable conditions.















**Note** Selections 2 and 4 cannot be selected in Legal for Trade balances.

1. Press .  displays.
2. Press  or  to scroll to **PERFORMANCE**.
3. Press . **21 STABLE** and the current setting displays.
4. Press . The current setting begins to flash.
5. Press  or  to select desired setting.
6. Press  to save the setting.
7. Press  to return to operation display.

### 5.3.2 Response Speed

The larger the value is set in this menu, the more stable the balance display becomes in unstable conditions.













1. Press .  displays.
2. Press  or  to scroll to **PERFORMANCE**.
3. Press . **21 STABLE** and the current setting displays.
4. Press  or  to scroll to **22 RESPONSE**.
5. Press . The current setting begins to flash.
6. Press  or  to select desired setting.
7. Press  to save the setting.
8. Press  to return to operation display.

### 5.3.3 Zero Tracking

The Zero Tracking function makes it possible to automatically correct the zero-point fluctuation when **0** is displayed, through which the **0** display is maintained.



**Note** Selections 1, 2 and 4 cannot be selected in Legal for Trade balances.

1. Press .  displays.
2. Press  or  to scroll to **PERFORMANCE**.
3. Press . **21 STABLE** and the current setting displays.
4. Press  or  to scroll to **23 ZERO TRAC**.
5. Press . The current setting begins to flash.
6. Press  or  to select desired setting.
7. Press  to save the setting.
8. Press  to return to operation display.

## 5.4 User Information

Describes setting items related to the comparator function and preset tare weight.

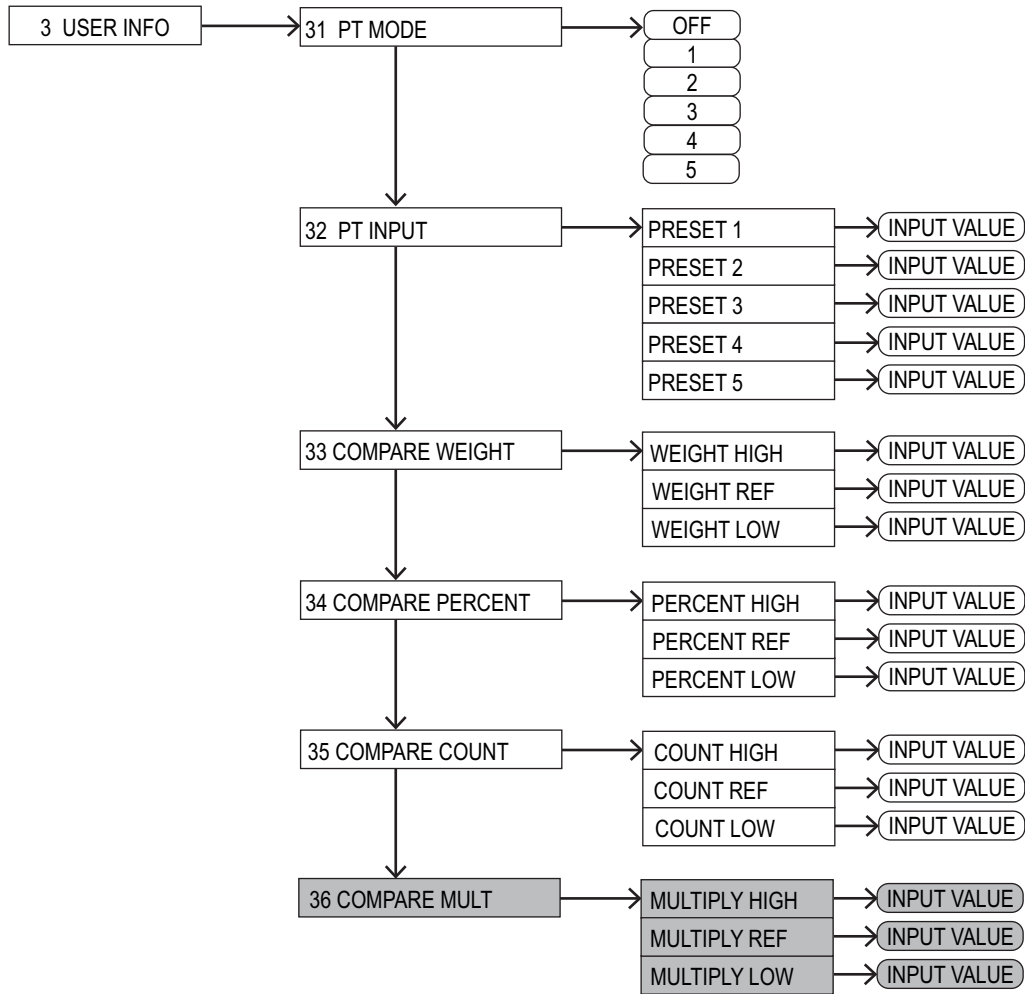

Figure 5-6. User Information Menu

Menu	Parameters	Description
31 PT MODE	Preset Tare Execution	
	Off	Invalid
	Setting 1-5	Execute
32 PT INPUT	Preset tare weight setting	
	Preset 1-5	Setting value input
33 COMPARE WEIGHT	Weight Comparator	
	Weight High	Setting value input
	Weight Ref	
	Weight Low	

Menu	Parameters	Description
34 COMPARE PERCENT	% Comparator	
	Percent High	Setting value input
	Percent Ref	
	Percent Low	
35 COMPARE COUNT	Comparator Counting	
	Count High	Setting value input
	Count Ref	
	Count Low	
36 COMPARE MULT	Multiple Comparator	
	Multiply High	Setting value input
	Multiply Ref	
	Multiply Low	

Table 5-6. User Information Menu

### 5.4.1 Preset Tare Mode



















A preset tare can be selected prior to weighing. See [Section 3.7.1 on page 9](#) for more information.

### 5.4.2 Input Preset Tare Value

There are two ways of inputting a preset tare weight value

- Actual value setting method (onW): Weighing a sample with a scale and then making it a setting value
- Numeric value setting method (NUM): Inputting a setting value directly via key operation

To enter a preset tare:

1. Press .  displays.
2. Press  or  to scroll to **USER INFO**.
3. Press . **31 PT MODE** displays.
4. Press  or  to scroll to **31 PT INPUT**.
5. Press . **PRESET 1** displays.
6. Press  or  to select desired preset tare (1-5).
7. Press . **SET PRESET onW NUM** displays.
8. Select  for **onW** or  for **NUM**.
  - If **onW** is selected, place the container on the scale, when weight is stable, press  to save
  - If **NUM** is selected use  or  to enter known value, press  to save
9. Press  to return to operation display. **NET PT** display in the upper right.

### 5.4.3 Set the Discrimination Value of Comparator Function

There are two ways of inputting a reference value and upper and lower limit values

- Actual value setting method (onW): Weighing a sample with a scale and then making it a setting value
- Numeric value setting method (NUM): Inputting a setting value directly via key operation

The discrimination is performed according to the following criteria:

#### Absolute Value

The discrimination is performed based on the upper and lower limit values that have been set in advance.

#### Relative Value

A reference numeric value is set in advance, and the discrimination is performed based on the range defined by the upper and lower limit values that have been set for the reference numeric value.

*Example:*



















*Two-point (upper and lower limits) setting, Reference value = 100.0000 g*

*Lower limit value = 90.0000 g, Upper limit value = 120.0000 g*

Discrimination Method	Reference value	Lower limit value	Upper limit value
	100.0000 g	90.0000 g	120.0000 g
Absolute value		90.0000 g	120.0000 g
Relative value	100.0000 g	-10.0000 g	20.0000 g

Table 5-7. Relative Value Example

To enter a value in the comparator function:

1. Press .  displays.
2. Press  or  to scroll to **USER INFO**.
3. Press . **31 PT MODE** displays.
4. Press  or  to scroll to the comparator function to be set.
5. Press  to enter the function.
6. Press  or  to select the parameter to set.
7. Press . Current function and **onW NUM** display.
8. Select  for **onW** or  for **NUM**.
  - If **onW** is selected, place the container on the scale, when weight is stable, press  to save
  - If **NUM** is selected use  or  to enter known value, press  to save
9. Press  to return to operation display. **NET PT** display in the upper right.

Repeat this section for each of the comparator settings:

- Comparator setting for Weighing mode: **33 COMPARE WEIGHT**
- Comparator setting for Percentage mode: **34 COMPARE PERCENT**
- Comparator setting for Counting mode: **35 COMPARE COUNT**
- Comparator setting for Multiplied by Coefficient mode: **36 COMPARE MULT**

## 5.5 External Input/Output Functions

This function is used for communication through the external peripheral devices. There is a RS-232C (D-SUB 9P) interface as standard equipment. See [Section 7.0 on page 43](#) for setup instructions.

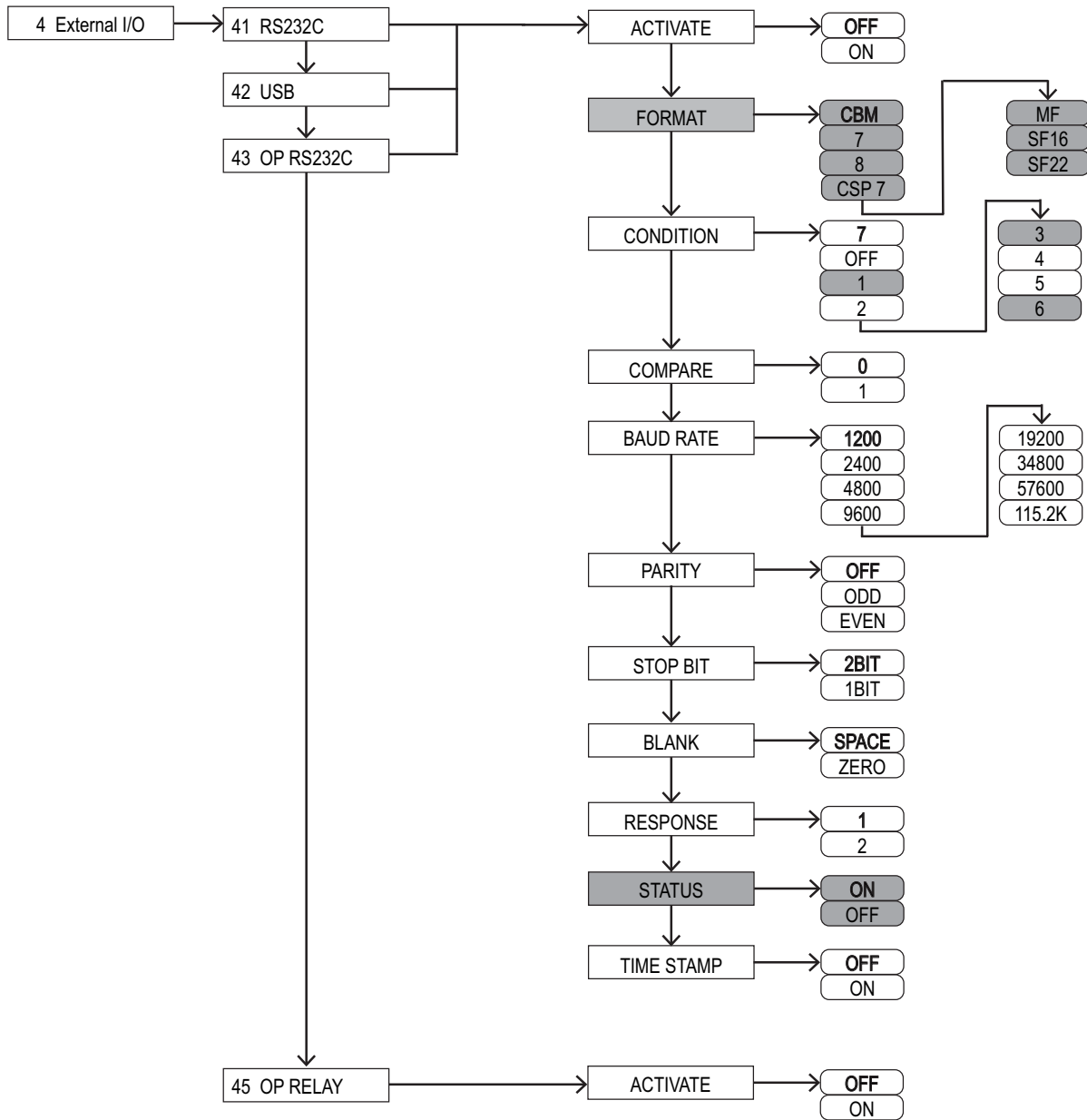

Figure 5-7. External Input/Output Menu Structure

Type	Menu	Parameters	Description
RS232C (Standard)	ACTIVATE	OFF	Stop
		ON	Operation
OP RS232C (Expanded Option)	FORMAT	CBM	CBM Format
		7	7 Digit Format
		8	8 Digit Format
		CSP 7	CSP Format 7 digits
		MF	MF Format
		SF16	SF Format 16 digits
		SF22	SF Format 22 digits
	CONDITION	7	Push down (output key) for one time output at stable times
		OFF	Output Stop
		1	Continuous output at all times
		2	Continuous output as stable
		3	Push down (output key) for one time instant output
		4	Auto output
		5	One time output at stable times
	COMPARE	0	Per output setting
		1	Output when discrimination result is okay or absent
	BAUD RATE	1200	1200 bps
		2400	2400 bps
		4800	4800 bps
		9600	9600 bps
		19200	19200 bps
		34800	34800 bps
		57600	57600 bps
		115.2K	115200 bps
	PARITY	OFF	NONE
		ODD	Odd Number
		EVEN	Even Number
	STOP BIT	2BIT	2 Bit
		1BIT	1 Bit
	BLANK	SPACE	Fill with a blank space (0 x 20)
		ZERO	Fill with 0 (0 x 30)
	RESPONSE	1	A00 Exx format
		2	ACK, NAK format
STATUS	OFF	Not added	
	ON	Append	
TIME STAMP	OFF	Not added	
	ON	Append	

Table 5-8. External Input/Output Parameters

## 5.6 Lock Functions

Limitations can be imposed on key operation and in accessing menu items.

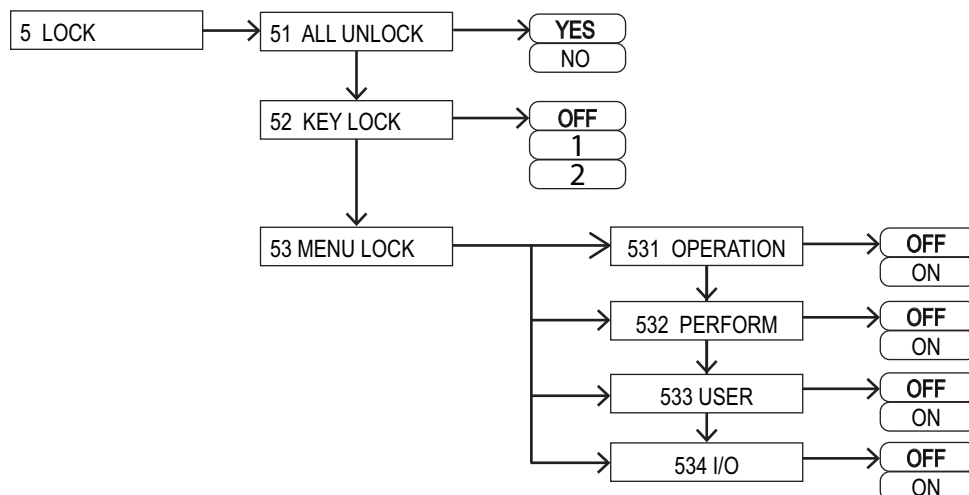

Figure 5-8. Lock Menu Structure

### 5.6.1 Total Lock Release

Use the following steps to release all the locks that have been set.



1. Press . displays.
2. Press or until displays.
3. Press . displays.
4. Press . displays.
5. Press (**YES**) or (**NO**).
6. Press . To return to the weigh mode.

### 5.6.2 Key Lock Function

Use the following steps to lock key operation.







1. Press . displays.
2. Press or until displays.
3. Press . displays.
4. Press or until displays.
5. Press . **OFF** starts flashing.



6. Press **F1** or **F2** to desired setting.
  - **OFF**: all keys are available
  - **1**:  locked for power off
  - **2**: All keys are locked (except ; when in menu mode all keys are available)
7. Press **F4**. The chosen setting displays.
8. Press  to return to the weigh mode.

### 5.6.3 Menu Lock Function

Various setting menus can be locked.

1. Press .  displays.
2. Press **F1** or **F2** until  displays.
3. Press **F4**.  displays.
4. Press **F1** or **F2** until  displays.
5. Press **F4**.  displays.
6. Press **F1** or **F2** to display the menus available for locking.
  - 531 OPERATION: Function related to the operation <1 APPLICATIONS>
  - 532 PERFORM: Function related to the performance <2 PERFORMANCE>
  - 533 USER: User information setting <3 USER INFO>
  - 534 I/O: External input/output functions <4 EXTERNAL I/O>
7. Press **F4** at each menu to be locked/unlocked. The current setting flashes.
8. Press **F1** or **F2** to display **ON** or **OFF**.
9. Press **F4**. Setting stops flashing.
10. When all menus are set, press  to return to the weigh mode.

## 5.7 Admin/Adjust Menu

Perform setting of the balance ID, the span adjustment and the date and time.

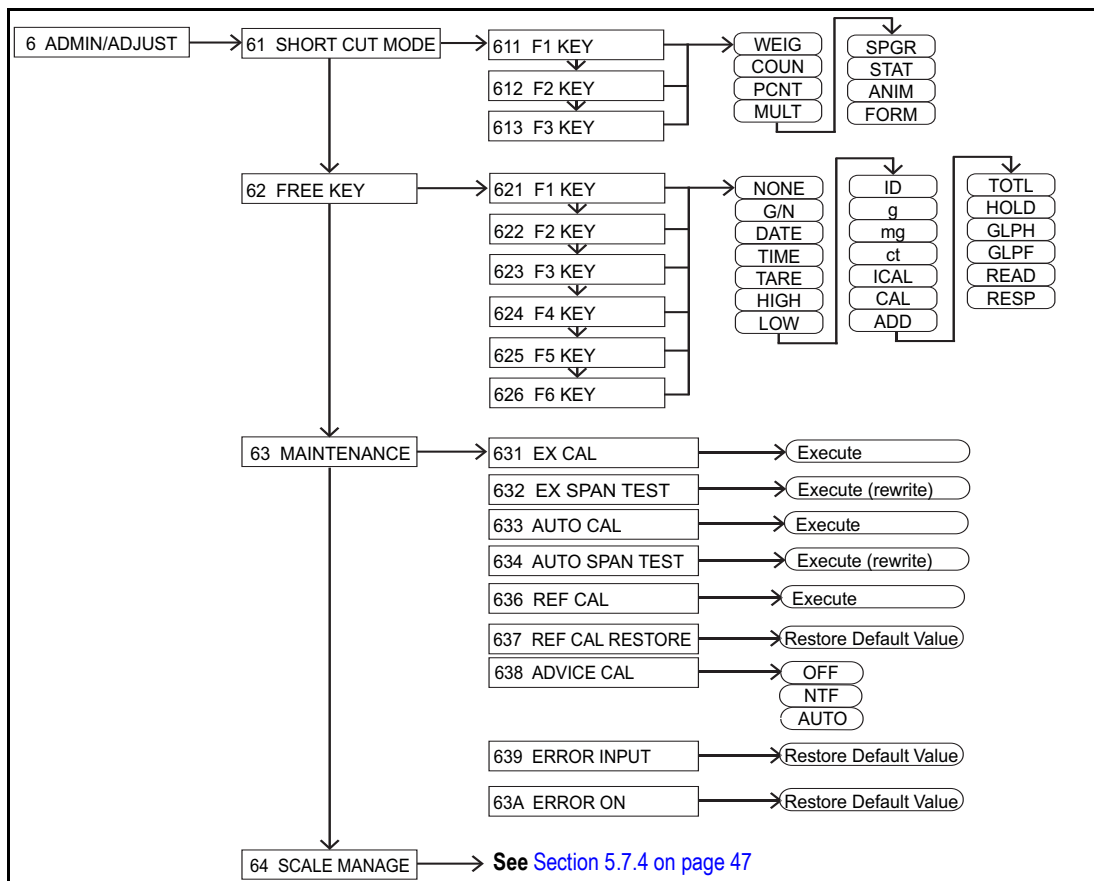

Figure 5-9. Controlling and Adjusting Menu Layout



Menu	Sub-Menu	Parameters – Description
61 SHORT CUT MODE	Key assignment for mode selection	
	611 F1 KEY – WEIG (default)	<b>WEIG</b> – Weigh Mode; <b>COUN</b> – Counting Mode; <b>PCNT</b> – Percentage Mode <b>MULT</b> – Multiplied by a Coefficient; <b>SPGR</b> – Specific Gravity Mode
	612 F2 KEY – COUN (default)	
	613 F3 KEY – PCNT (default)	
62 FREE KEY	Free key assignment; F1-F3 at layer 1; F4-F6 at layer 2	
	621 F1 KEY – G/N (default)	<b>G/N</b> – gross/net; <b>DATE</b> – date indication; <b>TIME</b> – time indication; <b>TARE</b> – tare indication; <b>HIGH</b> – upper limit value; <b>LOW</b> – lower limit value; <b>ID</b> – ID number indication <b>g</b> – unit setting; <b>mg</b> – unit setting; <b>ct</b> – unit setting; <b>ICAL</b> – internal span adjustment <b>CAL</b> – external span adjustment; <b>ADD</b> – adding execute; <b>TOTL</b> – total indication <b>HOLD</b> – measurement indication hold; <b>GLPH</b> – GLP header printing <b>GLPF</b> – GLP footer printing; <b>READ</b> – designation of readability (d) <b>RESP</b> – response speed; <b>NONE</b> – disabled
	622 F2 KEY – DATE (default)	
	623 F3 KEY – TIME (default)	
	624 F4 KEY – TARE (default)	
	625 F5 KEY – HIGH (default)	
	625 F5 KEY – HIGH (default)	
625 F6 KEY – LOW (default)		

Table 5-9. Controlling and Adjusting Parameters



Menu	Sub-Menu	Parameters – Description
63 MAINTENANCE	631 EX CAL	External Span Adjustment – Execute
	632 EX SPAN TEST	External Span calibration – Execute (rewrite)
	633 AUTO CAL	Internal Span Adjustment – Execute
	634 AUTO TEST SPAN	Internal Span calibration – Execute (rewrite)
	636 REF CAL	Calibrating with internal weight – Execute
	637 REF CAL RESTORE	Internal weight restore – Restore default value
	638 ADVICE CAL	Advice CAL and Auto CAL – OFF (Stop), NTF (Advice CAL), AUTO (Auto CAL)
	639 ERROR INPUT	Weight error input – Setting value input
	63A ERROR ON	Weight error reflection – OFF (Invalid), ON (Valid)

Table 5-9. Controlling and Adjusting Parameters (Continued)

### 5.7.1 Set Short Cut Mode



1. Press .  displays.
2. Press **F4**. **11 MODE** and the current operation mode displays.
3. Press **F1** or **F2** to scroll to **ADMIN/ADJUST**.
4. Press **F4**. The current sub-menu displays.
5. Press **F1** or **F2** to **SHORT CUT MODE**.
6. Press **F4**. The current F-Key displays.
7. Press **F4**. The current setting begins to flash.
8. Press **F1** or **F2** to select desired setting.
9. Press **F4** to save the setting.
10. Press  to return to operation display.

### 5.7.2 Set Free Keys

1. Press .  displays.
2. Press **F4**. **11 MODE** and the current operation mode displays.
3. Press **F1** or **F2** to scroll to **ADMIN/ADJUST**.
4. Press **F4**. The current sub-menu displays.
5. Press **F1** or **F2** to **FREE KEY**.
6. Press **F4**. The current F-Key displays.
7. Press **F1** or **F2** to scroll to desired F-Key.
8. Press **F4**. The current setting begins to flash.

9. Press **F1** or **F2** to select desired setting.
10. Press **F4** to save the setting.
11. Repeat [Steps 5-9](#) until all Free Keys are set.
12. Press  to return to operation display.

### 5.7.3 Maintenance Settings

1. Press   displays.
2. Press **F4**. **11 MODE** and the current operation mode displays.
3. Press **F1** or **F2** to scroll to **ADMIN/ADJUST**.
4. Press **F4**. The current sub-menu displays.
5. Press **F1** or **F2** to **MAINTENANCE**.
6. Press **F4**. The current parameter displays.
7. Press **F1** or **F2** to scroll to desired parameter.
8. Press **F4**. The current selection displays.
9. Press **F1** or **F2** to select desired selection.
10. Press **F4**. The current setting begins to flash.
11. Press **F1** or **F2** to select desired setting.
12. Press **F4** to save the setting.
13. Press  to return to operation display.

### 5.7.4 Balance Manage Menu

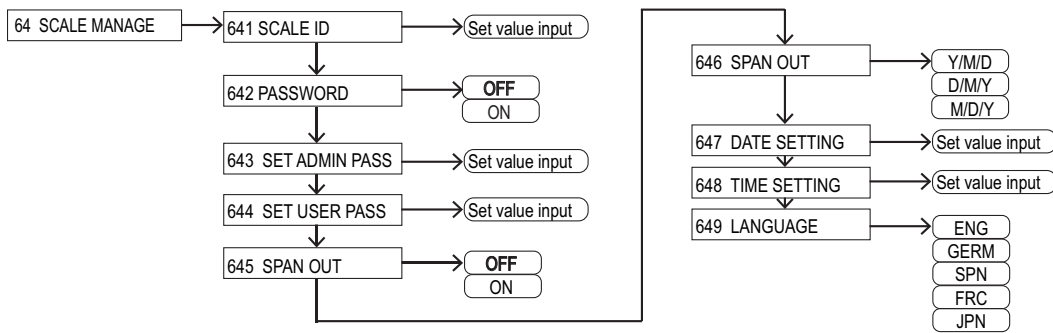

Figure 5-10. Controlling and Adjusting–Balance Manage Menu Layout

Menu	Parameters	Description
641 SCALE ID		Balance ID: Enter ID value
642 PASSWORD		Password Control
	OFF	Disabled
	ON	Enabled
643 SET ADMIN PASS		Administrators password registration–enter password value
644 SET USER PASS		User password registration–enter password value
645 SPAN OUT		Output of the span adjustment test
	OFF	Disabled
	ON	Enabled
646 DISP DATE		Date display format
	Y/M/D	Year, month, day
	D/M/Y	Day/month/year
	M/D/Y	Month/day/year
647 DATE SETTING		Enter date
648 TIME SETTING		Enter time
649 LANGUAGE		Printed Language
	ENG	English
	GERM	Deutsch
	SPN	Espanol
	FRC	French
	JPN	Japanese
64A READABILIT		Readability setting
	1	1d
	2	2d
	5	5d
	10	10d
64B START CAL		Span adjustment with internal weight at power on
	OFF	Disabled
	FORCE	Enabled
	SELEC	Selectable
64C DIRECT ST		Direct start setting
	OFF	Disabled
	ON	Enabled
64D INITIALIZE		Initialize
	YES	Cancel
	NO	Execute

Table 5-10. Controlling and Adjusting–Balance Manage Parameters

## 6.0 Scale Control and Adjustments

Use the following steps to access the span adjustment/test, calibration and other controlling and adjustment functions.

1. Press .  displays.

2. Press **F2** until **Admin/Adjust** appears.

Individual key presses can then be used for specific functions as shown in the [Figure 6-1](#) flow chart. Refer to the following sections within this chapter to complete the specific functions.

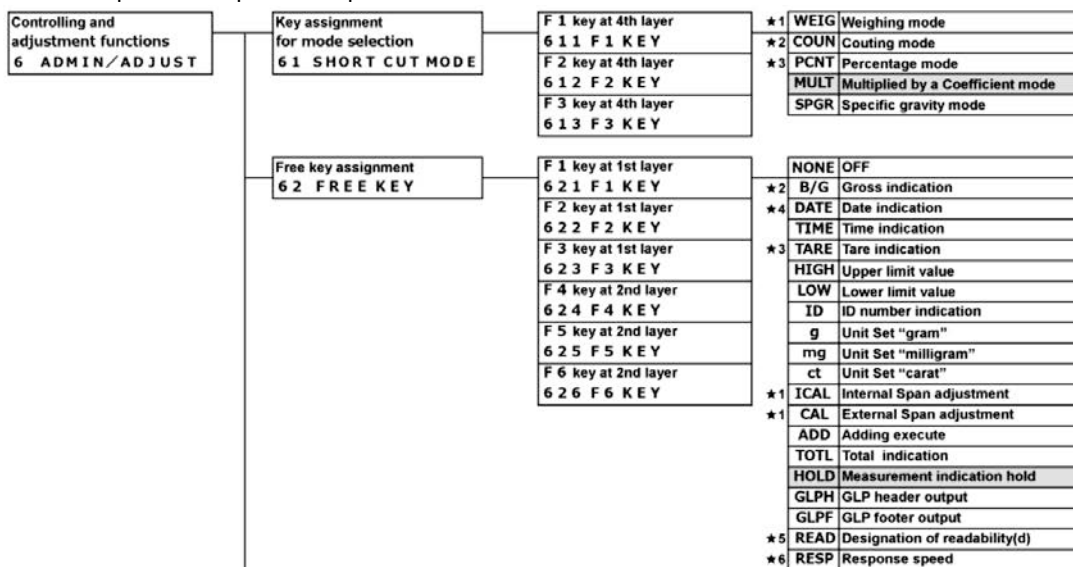



Figure 6-1. Control and Adjustment Menu

### 6.1 Measuring Mode Shortcuts

Shortcuts can be assigned to various measuring modes using the F keys which are displayed on the front panel of the TA Plus balance.

1. Press **F4** to change the mode.
2. Press **F2** to scroll to **Short Cut Mode**.
3. Press **F1** **611 F1 KEY** displays.
4. Press **F2** displays **612 F2 KEY**.
5. Press **F3** displays **613 F3 KEY**.
6. Press **F4**.
7. Press  to exit the setting menu.

## 6.2 Free Key

Various functions can be assigned to the F1 through F6 keys (which can be displayed in two different displays).

Note that the free key setting is valid only in the weighing mode.

Use the following steps to set up free keys.

1. Press **F4** to change the mode.
2. Press **F2** to scroll to **62 Free Key**.
3. Press **F1** **621 F1 KEY** displays.
4. Select the function to assign to the individual key. [Table 6-1](#) lists out the functions.

Parameter	Description
NONE	OFF
B/G	Gross indication
DATE	Date indication
TIME	Time indication
TARE	Tare value indication
HIGH	Upper limit value
LOW	Lower limit value
ID	ID number indication
g	Unit set gram
mg	Unit set milligram
ct	unit set carat
ICAL	Internal span adjustment
CAL	External span adjustment
ADD	Adding execute
TOTL	Total indication
HOLD	Measurement indication hold
GLPH	GLP header output
GLPF	GLP footer output
READ	Designation of readability (d)
RESP	Response speed

Table 6-1. Free Key Setting Parameters

5. Press **F2** displays **622 F2 KEY**
6. Press **F3** displays **623 F3 KEY**.
7. Press **F4** moves to a second layer of "free keys." **624 F4 KEY** displays.
8. Press **F5** displays **625 F5 KEY**.
9. Press **F6** displays **626 F6 KEY**.
10. Press  to exit the setting menu.

## 6.3 Balance Control Setting

The balance ID can be set to determine the balance. The balance ID is checked by the free key.

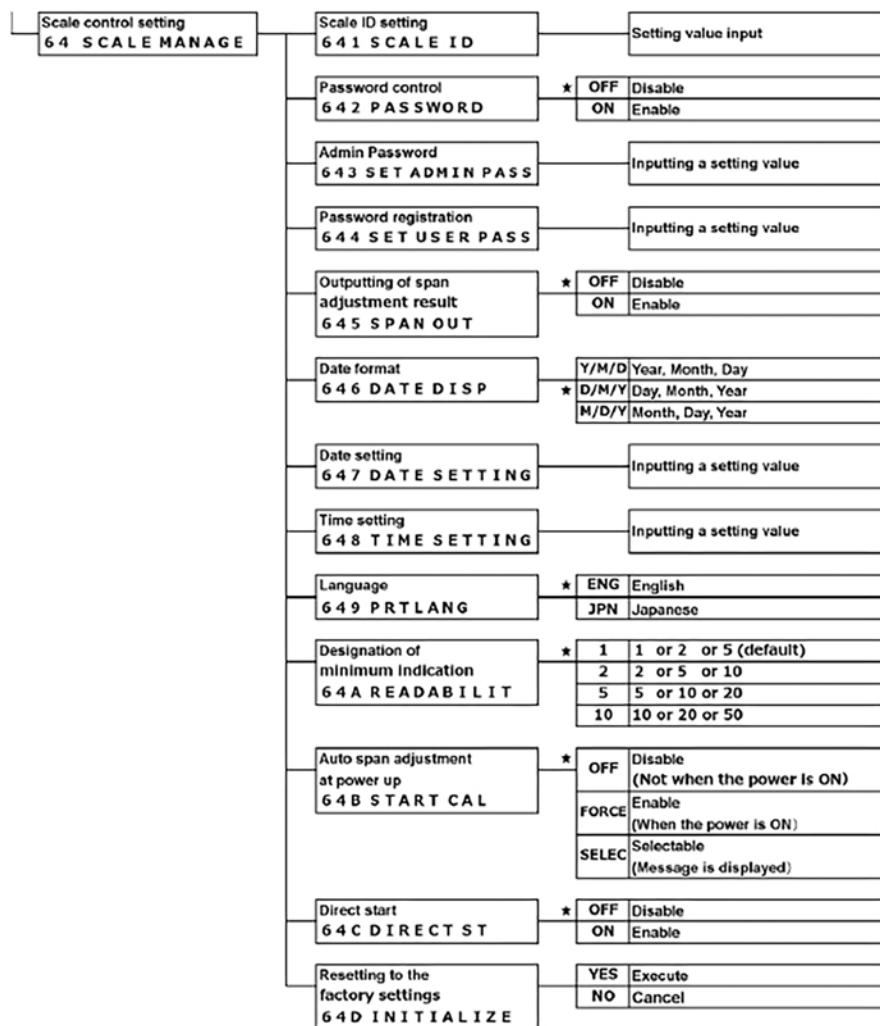



Figure 6-2. Scale Control Settings

### 6.3.1 Balance ID Setting

1. Press **F2** to scroll to **SCALE MANAGE**.
2. Press **F4** **641 SCALE ID** displays.
3. The digit for inputting blinks and press **F1** or **F2** to increment/decrement the digit to select.
4. Press **F3** to input to the next digit.
5. press **F1** or **F2** to increment/decrement the digit to select.
6. Press **F4** to save the selection. **641 BALANCE ID** displays.
7. Press  to exit the setting menu.



### 6.3.2 Password Control

The following steps enable or disable the password protection.

1. Press **F2** to scroll to **SCALE MANAGE**.
2. Press **F4** **642 PASSWORD** displays.
3. Press **F1** or **F2** to select OFF: disable or ON: enable.
4. Press **F4**.
5. Press  to exit the setting menu.

### 6.3.3 Set Administrative Password

The following steps set up a password for an administrator.

1. Press **F2** to scroll to **SCALE MANAGE**.
2. Press **F4** **643 SET ADMIN PASS** displays.
3. Press **F4** to input the password (four digits of 0-9 can be selected).
4. Press  to exit the setting menu.

### 6.3.4 Set User Password

The following steps set up a password for a user.

1. Press **F2** to scroll to **SCALE MANAGE**.
2. Press **F4** **644 SET USER PASS** displays.
3. Press **F4** to input the password (four digits of 0-9 can be selected).
4. Press  to exit the setting menu.





### 6.3.5 Outputting the Span Adjustment Result

After the span adjustment is complete, the results can be outputted automatically.

1. Press **F2** to scroll to **SCALE MANAGE**.
2. Press **F4** **645 SPAN OUT** displays.
3. Press **F1** or **F2** to select OFF: disable or ON: enable.
4. Press **F4**.
5. Press  to exit the setting menu.





### 6.3.6 Date Indication Format

Use the following steps to set up the date format.

1. Press  to scroll to **SCALE MANAGE**.
2. Press  **646 DATE DISP** displays.
3. Press .
4. Press  to exit the setting menu.





### 6.3.7 Date Setting

Use the following steps to set up dates

1. Press  to scroll to **SCALE MANAGE**.
2. Press  **647 DATE SETTING** displays.
3. The rightmost digit blinks so enter the date.
4. Press .
5. Press  to exit the setting menu.







### 6.3.8 Time Setting

Use the following steps to set time.

1. Press  to scroll to **SCALE MANAGE**.
2. Press  **648 TIME SETTING** displays.
3. The rightmost digit blinks so enter the date.
4. Press .
5. Press  to exit the setting menu.

### 6.3.9 Output Language

The Rice Lake TA Plus balance has two languages that can be set; English or Japanese. Use the following step to set a language.

1. Press  to scroll to **SCALE MANAGE**.
2. Press  **649 PRT LANG** displays.
3. Press  or  to select ENG: English or JPN: Japanese.
4. Press .
5. Press  to exit the setting menu.

### 6.3.10 Readability Setting

The larger the readability becomes, the less the balance is affected by external influences. In addition, the balances takes less time for the it to stabilize. Use the following steps to select a readability setting.

1. Press **F2** to scroll to **SCALE MANAGE**.
2. Press **F4** **64A READABILIT** displays.
3. Press **F1** or **F2** to select the following.

		The default readability		
		1	2	5
Set Value	1	1 (default)	2 (default)	5 (default)
	2	2	5	10
	5	5	10	20
	10	10	20	50

Table 6-2. Readability Settings

4. Press **F4**.
5. Press  to exit the setting menu.

### 6.3.11 Auto Span Adjustment with Internal Weight on Power up

1. Press **F2** to scroll to **SCALE MANAGE**.
2. Press **F4** **64B START CAL** displays.
3. Press **F1** or **F2** to select OFF - Disable, FORCE - Enable, SELEC - Selectable.
4. Press **F4**.
5. Press  to exit the setting menu.

### 6.3.12 Direct Start Setting

This function is used to turn on the TA Plus balance automatically without pushing  when connected to AC power.

1. Press **F2** to scroll to **SCALE MANAGE**.
2. Press **F4** **64C DIRECT ST** displays.
3. Press **F1** or **F2** to select OFF - Disable, ON - Enable.
4. Press **F4**.
5. Press  to exit the setting menu.

### 6.3.13 Resetting to Factory Settings

1. Press **F2** to scroll to **SCALE MANAGE**.
2. Press **F4** **64D INITIALIZE** displays.
3. Press **F3** or **F4** to select NO - Cancel, YES - Execute.
4. **64D INITIALIZE** displays.
5. Press  to exit the setting menu.

# 7.0 Communications

The balance can be connected to a computer using a compatible third party software program. Connections can be made using RS-232. Basic specifications include:

- RS-232C full duplex
- Asynchronous communication
- RS-232C: EIA-232-D/E
- Baud Rate: 1200-115200 bps
- Transmission: 1 start bit, non/odd/even number parity, 8 data bit, 1-2 stop bits

## 7.1 RS-232 Connections

The balance can be equipped with an optional RS-232 feature for communication with printers and computers.

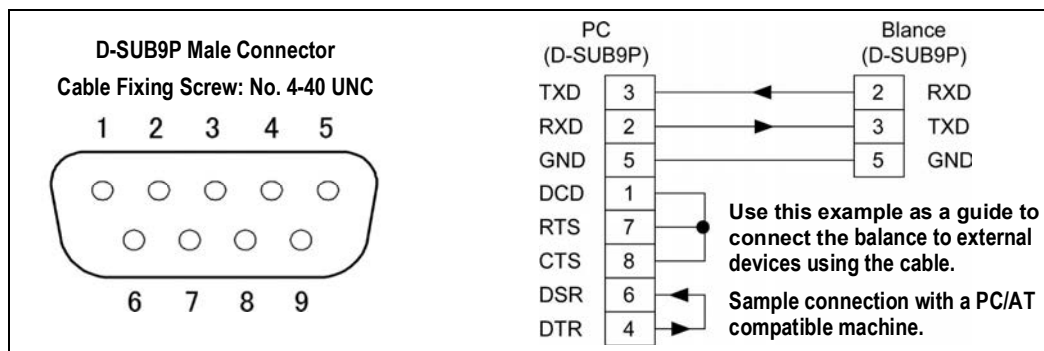

Figure 7-1. RS-232 Connection

Pin Number	Signal	Input/Output	Function
1	-	-	-
2	RXD	Input	Receive Data
3	TXD	Output	Transmit Data
4	DTR	Output	High (when the balance is powered on)
5	GND	-	Signal Grounding
6	-	-	-
7	-	-	-
8	-	-	-
9	Ext. Tare	Input	External Tare Range Setting

Table 7-1. Pin Connections



The DB-9 connector can set a tare range or adjust the zero point from an external device by connecting a contact or a transistor switch between the pin for externally setting a tare range (pin 9) and the signal ground (pin 5).

Allow at least 400 ms for connection (ON) time (Maximum voltage: 15 V when the balance is turned OFF, sink current: 20 mA when it is turned ON).

## 7.2 Basic Data Output Format

Date bit: 8 bit, Parity bit/Stop bit: Can be changed.

### 6-Digit Numeric Format

Consists of 14 characters, including terminators (CR=0xDH/LF=0xAH).

1	2	3	4	5	6	7	8	9	10	11	12	13	14
P1	D1	D2	D3	D4	D5	D6	D7	U1	U2	S1	S2	CR	LF

### 7-Digit Numeric Format

Consists of 15 characters, including terminators (CR=0xDH/LF=0xAH).

1	2	3	4	5	6	7	8	9	10	11	12	13	14	15
P1	D1	D2	D3	D4	D5	D6	D7	D8	U1	U2	S1	S2	CR	LF

### 8-Digit Numeric Format

Consists of 16 characters, including terminators (CR=0xDH/LF=0xAH).

1	2	3	4	5	6	7	8	9	10	11	12	13	14	15	16
P1	D1	D2	D3	D4	D5	D6	D7	D8	D9	U1	U2	S1	S2	CR	LF

### 7.2.1 Data Description

Symbol	Code	Description
P1 (one character) indicates the polarity of the data		
+	0x2B	Zero or positive data
-	0x2D	Negative data
D1 to D7/8/D9 (seven or eight or nine characters) stores the numeric data		
0-9	0x30-0x39	0 to 9 (numeric)
.	0x2E	Decimal point (floating)
(SP)	0x20	A space at the top of a numeric value Output to the least significant digit in the absence of a decimal point Unused high-order digit
U1, U2 (two characters) indicates the unit used to show numeric data		
M	G	0x4D 0x47 mg (milligram)
(SP)	G	0x20 0x47 g (gram)
C	T	0x43 0x54 ct (carat)
M	O	0x4D 0x4F mom (momme)
O	Z	0x4F 0x5A oz (ounce)
L	B	0x4C 0x42 lb (pound)
O	T	0x4F 0x54 ozt (troy ounce)
D	W	0x44 0x47 dwt (pennyweight)
G	R	0x47 0x52 GN (grain)
T	L	0x54 0x4C tH (Hong Kong tael)
T	L	0x54 0x4C tS (Singapore, Malaysia tael)
T	L	0x54 0x4C tT (Taiwan tael)
t	o	0x74 0x6F to (tola)
M	S	0x4D 0x53 MSG (mesghal)
B	A	0x42 0x41 BA (baht)
P	C	0x50 0x43 PCS (parts counting)
(SP)	%	0x20 0x25 % (percentage weighing)
(SP)	#	0x20 0x23 # (multiplied by the coefficient)
(S1) (one character) indicates the judgment result when the limit function is used		
L	0x4C	Shortage (low)

Table 7-2. Data Description

Symbol	Code	Description
G	0x47	Proper (ok)
H	0x48	Over (high)
(SP)	0x20	No judgment result or data type specified
e	0x65	Net weight
f	0x66	Tare weight
P	0x50	Preset tare weight
T	0x54	Total value (accumulated value)
U	0x55	Unit weight
d	0x64	Gross
S2 (one character) indicates the status		
S	0x53	Data stable
U	0x55	Data unstable
E	0x45	Data error (indicates that data other than S2 is invalid)
(SP)	0x20	No status specified

Table 7-2. Data Description (Continued)

### 7.3 CBM Data Output Format

Consists of 26 characters, including terminators (CR=0xDH/LF=0xAH).

(Data bit: 8, Parity: stop, stop bit: can be changed)

1	2	3	4	5	6	7	8	9	10	11	12	13	(SP): space
S1	C1	(SP)	T1	T2	T3	T4	T5	T6	D1	D2	D3	D4	
14	15	16	17	18	19	20	21	22	23	24	25	26	
D5	D6	D7	D8	D9	D10	D11	D12	U1	U2	(SP)	CR	LF	
1	2	3	4	5	6	7	8	9	10	11	12	13	(SP): space
*	*	(SP)	E	R	R	O	R	(SP)	*	*	*	*	
14	15	16	17	18	19	20	21	22	23	24	25	26	
*	*	*	*	*	*	*	*	*	*	(SP)	CR	LF	

#### 7.3.1 CBM Data Description

Symbol	Code	Description											
[S1] (1 character) Represents the status.													
(SP)	0x20	Data stable											
*	0x2A	Data unstable											
[C1] (1 character) Represents the result of comparator function.													
(SP)	0x20	Comparator result: Proper (OK) or No result											
H	0x48	Over (HIGH)											
L	0x4C	Shortage (LOW)											
[T1-T6] (6 characters) Represents the type of the data.													
(SP)	(SP)	(SP)	(SP)	(SP)	(SP)	0x20	0x20	0x20	0x20	0x20	0x20	0x20	Net weight (not tared)
N	(SP)	(SP)	(SP)	(SP)	(SP)	0x4E	0x20	0x20	0x20	0x20	0x20	0x20	Net weight (tared)
P	T	(SP)	(SP)	(SP)	(SP)	0x50	0x54	0x20	0x20	0x20	0x20	0x20	Preset tare weight
T	(SP)	(SP)	(SP)	(SP)	(SP)	0x54	0x20	0x20	0x20	0x20	0x20	0x20	Tare weight
T	O	T	A	L	(SP)	0x54	0x4F	0x54	0x41	0x4C	0x20	0x20	Total value (Accumulated value)
G	(SP)	(SP)	(SP)	(SP)	(SP)	0x47	0x20	0x20	0x20	0x20	0x20	0x20	Gross
U	N	I	T	(SP)	(SP)	0x55	0x4E	0x49	0x54	0x20	0x20	0x20	Unit weight

Table 7-3. Data Description

Symbol	Code	Description
[D1-D12] (12 characters) Numeric value data is stored.		
+	0x2B	When the data are 0 or positive
-	0x2D	When the data are negative
0-9	0x30 – 0x39	Numeric value (0 – 9)
.	0x2E	Decimal point (floating decimal point)
[	0x5B	The number surrounded by '['and ']' means auxiliary indication
]	0x5D	
(SP)		Spaces fill the top of the data; Output to the least significant digit in the absence of a decimal point Unused high-order digit

Table 7-3. Data Description (Continued)

Symbol	Code	Description
[U1, U2] (2 characters) Represents the unit of numeric value data.		
m	g	0x6D 0x67 mg (milligram)
(SP)	g	0x20 0x67 g (gram)
c	t	0x63 0x74 ct (carat)
m	o	0x6D 0x6F mom (momme)
o	z	0x6F 0x7A oz (ounce)
l	b	0x6C 0x62 lb (pound)
O	T	0x4F 0x54 ozt (troy ounce)
d	w	0x64 0x77 dwt (pennyweight)
G	R	0x47 0x52 GN (grain)
t	l	0x74 0x6C tlH (Hong Kong tael)
t	l	0x74 0x6C tlS (Singapore, Malaysia tael)
t	l	0x74 0x6C tlT (Taiwan tael)
t	o	0x74 0x6F to (tola)
M	S	0x4D 0x53 MSG (mesghal)
B	A	0x42 0x41 BAAt (baht)
P	C	0x50 0x43 PCS (parts counting)
(SP)	%	0x20 0x25 % (percentage weighing)
(SP)	#	0x20 0x23 # (multiplied by coefficient)

Table 7-4. Data Description



## 7.4 Input Commands

Input commands can be entered from an external device. [Table 7-5](#) displays measuring mode input commands.

Commands			
Measuring Mode	Zero-point Adjustment	Output Control	External Contact Input
	Tare Subtraction Date/time Output	Comparator Setting Preset Tare Setting Interval Time Setting	
Weighing	x	x	x
Counting	x	x	x
Percentage	x	x	x
Multiply	x	x	x
Specific gravity	x	-	x

Table 7-5. Transmission Procedure

Select an input command. The balance sends normal completion response or the requested result data.

- The balance transmits an error response if the operation is unsuccessful or if the command is invalid
- In normal display mode, the balance sends a response within one second of receiving the command; a response is sent for tare range, span adjustment or span test commands
- Do not send a command to the balance until a response from the previous command is received from the balance

The balance needs additional response time in some situations:

- The balance waits for stability after receiving a tare or a zero-point adjustment command if <17 WT STABLE> is <ON>
- If the balance receives a command when setting a function, when it is under span adjustment or if it is busy for other reasons, the command is executed after the current operation is completed

### 7.4.1 Input Command Composition 1

This is composed of four characters including the terminator (CR=0xDH/LF=0cAH).

C1	C2	CR	LF
----	----	----	----

## 7.5 Command Formats

**IMPORTANT** Do not confuse the alphabetical O for Arabic number 0 (Zero).

C1	C2	Code Ψ C1)	Code Ψ C2)	Description	Response	
					A00/Exx format	ACK/NAK format
T	(SP)	0x54	0x20	Tare	A00: Normal response  E01: Abnormal response	ACK: Normal response  NAK: Abnormal response
Z	(SP)	0x5a	0x20	Zero-point adjustment		
O	0	0x4f	0x30	Stop output		
O	1	0x4f	0x31	Continuous output		
O	2	0x4f	0x32	Continuous output (no output when unstable)		
O	3	0x4f	0x33	Press output key for one-time output		
O	4	0x4f	0x34	Auto output		
O	5	0x4f	0x35	One-time output when stable		
O	6	0x4f	0x36	One-time output when stable		
O	7	0x4f	0x37	Press output key for one-time output when stable		
Commands O0 to O7: <ul style="list-style-type: none"> <li>• Have the same functions as the output control set by the setting menu</li> <li>• Once commands are executed, that state is maintained; the status is reset to the setting menu when the balance is turned on again</li> </ul>						
O	8	0x4f	0x38	One-time output		
O	9	0x4f	0x39	One-time output after stability is obtained		
Command O8 to O9: <ul style="list-style-type: none"> <li>• Are used to request data from the balance</li> <li>• After the command is executed, it returns to O0</li> </ul>						
O	A	0x4f	0x41	Interval function (Output each time the output time has elapsed)		
O	B	0x4f	0x42	Interval function (Output when stable each time the output time has elapsed)		
When OA or OB command is sent, the interval function starts and must be sent again to end the function						

Table 7-6. Zero Point Adjustment/Tare/Output Control Setting Command

C1	C2	Code (C1)	Code (C2)	Description	Response
D	D	0x44	0x44	Date output request	Date data
D	T	0x44	0x54	Time output request	Time data

Table 7-7. Data Output Request and Time Output Request

### 7.5.1 Input Command Composition 2

This is composed of 15 characters including the terminator (CR=0xDH/LF=0xAH).

1	2	3	4	5	6	7	8	9	10	11	12	13	14	15
C1	C2	,	C3	C3	C3	C3	C3	C3	C3	C3	C3	C3	CR	LF

C3 has a 10 digit maximum (including the polarity +/-, comma and point). Do not include the measuring unit.

*Example: Upper limit input 1200.00g: LA,1200.00*

*Preset tare input 1000.00g: PT,1000.00*

*Interval time input 12:34:56: IA,12,34,56 (marked off by commas)*

The Input command can be entered when Weighing mode, Percentage mode, Counting mode or Multiplied by Coefficient mode are being used. If input when in an other modes, the outputs an abnormal response.

If the input value is not correct, the balance outputs an abnormal response.

C1	C2	Code (C1)	Code (C2)	Description	C3	Response	
						A00/Exx format	ACK/NAK format
L	A	0x4C	0x41	Upper limit value setting	Numeric value setting	A00: Normal response	ACK: Normal response
L	B	0x4C	0x42	Lower limit value setting	Numeric value setting	E01: Abnormal response	NAK: Abnormal response
L	C	0x4C	0x43	Reference value setting	Numeric value setting	Abnormal response	Abnormal response

Table 7-8. Comparator Setting Command

C1	C2	Code (C1)	Code (C2)	Description	C3	Response	
						A00/Exx format	A00/Exx format
P	T	0x50	0x54	Preset tare value setting	Numeric value setting	A00: Normal response E01: Abnormal response	ACK: Normal response NAK: Abnormal response

Table 7-9. Preset Tare Value Setting Command



**Note** When the normal response, the preset tare value is input in 321 PRESET 1 and the balance operates Preset tare. If the input value is 0 at Preset tare setting value command, the preset tare operation is canceled

C1	C2	Code (C1)	Code (C2)	Description	C3	Response	
						A00/Exx format	A00/Exx format
I	A	0x49	0x41	Interval (output) time setting	Numeric value setting	A00: Normal response E01: Abnormal response	ACK: Normal response NAK: Abnormal response

Table 7-10. Interval (Output) Time Setting Command

## 7.6 Response

The Response Command Format consists of five characters including terminators.

1	2	3	4	5
A1	A2	A3	CR	LF

Table 7-11. Response Command Format (A00/Exx format)

A1	A2	A3	Code (A1)	Code (A2)	Code (A3)	Description
A	0	0	0x41	0x30	0x30	Normal response
E	0	1	0x45	0x30	0x31	Abnormal response

Table 7-12. Response Command

Response Command Format consists of one character without a terminator.

1
A1

Table 7-13. Response Command Format (ACK/NAK format)

A1	Code(A1)	Description
ACK	0x06	Normal response
NAK	0x15	Abnormal response

Table 7-14. Response Command

## 7.7 External Contact Input

D-sub9 connectors can set a tare range or adjust the zero-point from an external device by connecting a contact or a transistor switch between the pin for externally setting a tare range (Pin 9) and the signal ground (Pin 5). Allow at least 400 ms for the connection (ON) time.

Maximum voltage: 15 V when the balance is turned off. Sink current: 20 mA when it is turned on.



**While external contact input is selected, command input is not available.**

**There is no response command corresponding to external contact input.**

## 7.8 Communication Settings

Set the communication source desired:

Standard RS232C

Extension RS232/Ethernet (Optional)

Relay Contact Output (Optional)

















**Output condition, 413 CONDITION 1,3,6, cannot be selected.**

**433 CONDITION 1,3 and 6 cannot be selected only when Extension RS232C option is connected.**

**41A STATUS, 42A STATUS and 43A STATUS cannot be selected. The net value status is always appended.**















Use the following steps to activate the desired communication source.

1. Press .  displays.
2. Press  or  to select **EXTERNAL I/O**.
3. Press . The current setting displays.

4. Press  or  to select the communication source desired.
5. Press  to enter the menu.
6. Press  or  to display **ACTIVATE**.
7. Press . The current setting begins flashing.
8. Press  or  to select **OFF** or **ON**.
9. Press  to save the setting.
10. Press  to return to operation display.

## 7.9 Set Communication Parameters

To set the parameters for the communication source:

1. Press   displays.
2. Press  or  to select **EXTERNAL I/O**.
3. Press . The current setting displays.
4. Press  or  to select the communication source desired.
5. Press  to enter the menu.
6. Press  or  to display the parameter to set.
7. Press . The current parameter setting begins flashing.
8. Press  or  to select desired setting.
9. Press  to save the setting.
10. Repeat process until all parameters have been set.
11. Press  to return to operation display.

See [Section 6.5 on page 35](#) for parameters and settings that are available.

### 7.9.1 Optional Relay Contact Output

When using the Relay Contact Output, the **COMPARE** parameter in the **Extension RS232/Ethernet (Optional)** communication source, must be set to:

- 0: AA's per the comparator setting. See [Section 3.17 on page 19](#)
- 1: Output when discrimination result is OK or absent

Set the **EXTERNAL I/O** to **OP RELAY**. See [Section 7.8 on page 62](#).

## 7.10 Print Examples

English	Spanish	English	Spanish	English	Spanish	English	Spanish
<p>GLP Header</p> <pre> TYPE: S/N: ID: START DATE: TIME:                 </pre>	<p>TIPO: No S. ID.: INICIO FECHA: HORA:                 </p>	<p>**CALIBRATION**</p> <pre> DATE: TIME: TYPE: S/N: ID: CAL. EXTERNAL REF:                 </pre>	<p>**CALIBRACION**</p> <pre> FECHA: HORA: TIPO: No S. ID.: CAL. EXTERNA REF.:                 </pre>	<p>**CALIBRATION**</p> <pre> DATE: TIME: TYPE: S/N: ID: CAL. INTERNAL REF:                 </pre>	<p>**CALIBRACION**</p> <pre> FECHA: HORA: TIPO: No S. ID.: CAL. INTERNA REF.:                 </pre>	<p>****REF. CAL****</p> <pre> DATE: TIME: TYPE: S/N: ID: REF:                 </pre>	<p>**REF. CAL. **</p> <pre> FECHA: HORA: TIPO: No S. ID.: REF.:                 </pre>
<p>GLP Footer</p> <pre> END DATE: TIME: SIGNATURE                 </pre>	<p>FIN FECHA: HORA: FIRMA                 </p>	<p>COMPLETE DATE: TIME: SIGNATURE                 </p>	<p>COMPLETADA FECHA: HORA: FIRMA                 </p>	<p>COMPLETE DATE: TIME: SIGNATURE                 </p>	<p>COMPLETADA FECHA: HORA: FIRMA                 </p>	<p>COMPLETE DATE: TIME: SIGNATURE                 </p>	<p>COMPLETADA FECHA: HORA: FIRMA                 </p>
		<p>Span adjustment result output (external weight)</p>		<p>Span adjustment result output (internal weight)</p>		<p>Calibration result output (internal weight)</p>	
<p>Time &amp; Date</p> <pre> DATE: TIME:                 </pre>	<p>FECHA: HORA:                 </p>	<p>***SPAN TEST***</p> <pre> DATE: TIME: TYPE: S/N: ID: CAL. EXT. TEST REF:                 </pre>	<p>PRUEBA AMPLITUD FECHA: HORA: TIPO: No S. ID.: PRUE. CAL. EXT. REF.:                 </p>	<p>***SPAN TEST***</p> <pre> DATE: TIME: TYPE: S/N: ID: CAL. INT. TEST REF:                 </pre>	<p>PRUEBA AMPLITUD FECHA: HORA: TIPO: No S. ID.: PRUE. CAL. INT. REF.:                 </p>	<p>**FORMULATION**</p> <pre> DATE: TIME: TYPE: S/N: ID:                 </pre>	<p>**FORMULACION**</p> <pre> FECHA: HORA: TIPO: No S. ID.:                 </pre>
<p>Specific Gravity measurement mode (water temperature input)</p> <pre> SAMPLE SP GR SAMPLE WEIGHT WATER TEMP                 </pre>	<p>MUESTRA SP. GR PESO MUESTRA TEMP. DE AGUA                 </p>	<p>ERROR:                 </p>	<p>ERROR:                 </p>	<p>ERROR:                 </p>	<p>ERROR:                 </p>	<p>Formulation mode header</p> <pre> N T TOTAL N TOTAL SIGNATURE                 </pre>	<p>N TOTAL TARA TOTAL NETO FIRMA                 </p>
<p>Specific Gravity measurement mode (liquid input)</p> <pre> SAMPLE SP GR SAMPLE WEIGHT MED. LIQ SP GR                 </pre>	<p>MUESTRA SP. GR PESO MUESTRA MED. LIQU. SP. GR                 </p>	<p>COMPLETE DATE: TIME: SIGNATURE                 </p>	<p>COMPLETADA FECHA: HORA: FIRMA                 </p>	<p>COMPLETE DATE: TIME: SIGNATURE                 </p>	<p>COMPLETADA FECHA: HORA: FIRMA                 </p>	<p>Formulation mode footer</p> <pre> N T                 </pre>	<p>N TOTAL TARA TOTAL NETO FIRMA                 </p>
		<p>Span test result output (external weight)</p>		<p>Span test result output (internal weight)</p>		<p>Formulation mode Net value and tare value output</p>	
<p>Statistics mode header</p> <pre> **STATISTICS** DATE: TIME: TYPE: S/N: ID: N SUM MAX MIN R AVE SD CV                 </pre>	<p>* ESTADISTICAS* FECHA: HORA: TIPO: No S. ID.: N SUM MAX MIN R AVE SD CV                 </p>						

Figure 7-2. Print Examples

## 8.0 Troubleshooting and Maintenance

---

This section covers basic troubleshooting and maintenance of the balance.

**IMPORTANT**

**Observe proper disposal.**

*\*This balance, including accessories may not be disposed of in domestic waste in conformance with the specific requirements of the country, county and local jurisdictions. When disposing of the product, contact local authorities and ask for the proper method of disposal.*

*\*Do not use volatile solvents on the balance.*

*\*Unplug the AC adapter from the receptacle when the balance is not going to be used for a long period of time.*

### 8.1 Precautions Related to the Main Unit of the Balance

#### Operating Precautions

- If equipped with a dust cover, the balance may be unstable due to static electricity charged on the cover at low humidity
- Wipe the cover with a wet cloth, use an anti-static agent, or use the balance with the cover removed
- For more stable measurements, it is recommended to turn the balance on for at least 30 minutes and load the balance a few times with a weight equivalent to the weighing capacity before adjustment

#### Adjustments

- Calibrate the balance periodically with a test weight or use an internal adjustment weight
- Turn the balance on for at least 30 minutes and load the balance a few times with a weight equivalent to the weighing capacity before adjustment
- Adjustments are also needed in the following cases:
  - Using the balance for the first time
  - Using the balance after a long period of non-use
  - Changing the location of the balance
  - There is a large change in temperature, humidity or atmospheric pressure

#### Maintenance

- Dirt or liquids on the weighing pan can cause errors or an unstable weight reading
- Clean the balance frequently, ensuring that dust or liquids don't enter into the internal parts of the balance

## 8.2 Error Messages

Error Message/ Error Code	Cause	Solution
OVER ERROR	Weight exceeds maximum capacity	Split load into several smaller loads and weigh them Replace the tare with a lighter one
	Result exceeds the maximum display digit	Clear the calculation result, if the calculation results exceed the maximum display digit it will continue to do so
UNDER ERROR	The load is below the lower limit	Check the position of the weigh pan and reset if necessary Check for contact with other objects; use the included pan base only
DISPLAY ERROR	The result exceeds the maximum display digit	If calculation results exceed the maximum display digit, it will continue to do so unless something is changed
LOWER ERROR	The specimen weight/reference weight in Counting/Percentage Mode is below the lower limit	Ensure the specimen weight/reference weight is higher than the lower limit
ERR001 ERR099	System error	Record the error code and notify the dealer or Rice Lake Weighing Systems
ERR703	Operation key pushed when unit is in standby Hardware issue	Ensure operation key is not pushed when unit is in standby or starting up from standby Record the error code and notify the dealer or Rice Lake Weighing Systems
ERR705	Initial zero adjustment error Initial zero adjustment was not completed during startup due to the unstable load	Ensure weigh pan is properly placed Check for contact with other objects Check for wind or vibration
ERR706	Load is out of initial zero adjustment range	Ensure load pan is empty when balance is powered on
ERR709 ERR710 ERR711	Load is unstable at zero adjustment/tare subtraction Span adjustment time-out error	Improper setting of the weighing pan or pan base is suspected Check for contact with other objects Check for wind or vibration
ERR717	Mass of calibration weight differs from designated mass by 1% or more in external span adjustment	Check the calibration value of the weight and use the proper calibration weight
ERR718	The mass of the calibration weight is under 50% of the maximum capacity at span adjustment or internal span adjustment weight adjustment by external calibration weight	Use a calibration weight which is equal to the maximum capacity
ERR719	Adjust value by external span adjustment or internal span adjustment is over 1% of maximum capacity	Execute a <b>637 REF CAL RESTORE</b> , then execute an internal span adjustment Check the mass of the weight used for the external span adjustment Perform a <b>636 REF CAL</b>
ERR722	Tare key is pushed during the preset tare operation	Ensure Tare key is not pushed during preset tare operation
ERR723	Out of Zero adjustment range (1.5% of maximum capacity)	Ensure weigh pan is empty while performing a zero adjustment
ERR724	Out of Tare subtraction range (0 g to maximum capacity)	Ensure tare weight is within the tare subtraction range
ERR734	Weight of the sample is out of the importing range at actual value setting method at Percentage Mode (lower limit to maximum capacity)	Load the sample of which weight is within the importing range
ERR735	Time-out error of importing the sample weight in the actual value setting method at Percentage Mode	Improper setting of the weighing pan or pan base is suspected Check for contact with other object Check for any wind or vibration
ERR736	The setting value is out of the setting range at numeric value setting method at Percentage Mode (lower limit to maximum capacity)	Set the value within the range

Table 8-1. Error Codes



Error Message/ Error Code	Cause	Solution
ERR737	Sample weight in the air is out of importing range at Specific Gravity Mode (over 0g to maximum capacity) Sample weight in the water/liquid is out of the importing range at Specific Gravity Mode (0 – maximum capacity to maximum capacity)	Divide the sample so its weight in the air is within the importing range
ERR738	Time-out error in importing the sample weight in the water/liquid at Specific Gravity Mode	Ensure weigh pan is properly seated Check for contact with other object Check for draft or vibration
ERR739	Time-out error of importing the sample weight of the value setting method of Preset tare setting	Ensure weigh pan is properly seated Check for contact with other objects Check for any draft or vibration
ERR740	The setting value is out of the setting range at numeric value setting method or actual value setting method at Preset tare setting (0g to maximum capacity)	Set the tare within the tare subtraction range
ERR741	<b>631 EX CAL</b> is executed while the external span adjustment function is disabled	Contact the dealer or Rice Lake Weighing Systems
ERR742	Internal span adjustment device is not working	Contact the dealer or Rice Lake Weighing Systems
ERR743	Battery power is too low to execute <b>633 INT CAL</b> , <b>634 INT SPAN TEST</b> or <b>636 REF CAL</b>	Replace batteries
ERR746	Invalid date or time was input <b>647 DATE SETTING</b> or <b>648 TIME SETTING</b>	Set the time and date correctly
ERR747	When importing a specimen weight in comparator function value setting method, there is a time-out error	Ensure weigh pan is properly placed Check for contact with other objects Check for draft or vibration
ERR748	The setting value is out of the setting range at numeric value setting method or actual value setting method at Comparator mode ( <b>0 – maximum capacity to maximum capacity</b> )	Set value within range
ERR749	When importing a specimen weight in adding function value setting method, there is a time-out error	Ensure weigh pan is properly placed Check for contact with other objects Check for draft or vibration
ERR750	Weight of added sample is out of range ( <b>0 – maximum capacity</b> )	Choose sample within importing range
	The total value exceeds maximum display digit	Clear total value
ERR751	Weight of sample is lighter than the minimum interval of the balance in Counting Mode	Choose a sample which unit weight is more than minimum interval of the balance
ERR752	Weight of sample is 0g or under in Counting Mode	Choose sample which unit weight is more than the minimum interval of the balance Counting Mode cannot operate subtractive counting
ERR753	Time-out error of importing the unit weight at Counting Mode	Ensure weigh pan is properly placed Check for contact with other objects Check for draft or vibration
ERR754	Deleted the latest data then executed deleting operation of the second latest data at Statistics Mode	Only the latest data can be deleted Select <ALL> to delete all the other data
ERR760	Adding operation is executed while the Adding function is disabled	Set <b>141 ACTIVATE ON</b> then execute the adding operation
ERR761	An error occurred at <b>636 REF CAL</b>	Re-execute <b>636 REF CAL</b>
ERR763	Calculation error in specific gravity of the sample in Specific Gravity Mode	Re-execute the specific gravity function
ERR764	External weight used for <b>631 EX CAL</b> is different from selected weight range at <b>SELECT WEIGHT</b>	Use a weight that is within the selected range
ERR 768	The setting value is out of range at <b>639 ERROR INPUT</b>	Use the external calibration weight with error $\pm 100$ mg and under

Table 8-1. Error Codes (Continued)

Error Message/ Error Code	Cause	Solution
ERR 769	Calculation error of solid specific gravity	Re-execute specific gravity measurement
ERR 770	Calculation error of liquid specific gravity	Re-execute specific gravity measurement

Table 8-1. Error Codes (Continued)

### 8.3 Basic Maintenance

Use the following instructions to complete general maintenance on the TA Plus balance.

#### 8.3.1 Cleaning

1. Remove the pan.
2. Remove the pan base.
3. Remove windshield door.
4. Turn windshield ring counterclockwise until it stops.
5. Pull the windshield straight up to remove.
6. Wipe away dirt with a dry, soft clean cloth. If heavily soiled, remove the weigh pan and the pan base and clean with a clean cloth slightly dampened with a neutral detergent.



**Using chemical agents, solvents or wipes could damage the windshield panel**

#### 8.3.2 Dimensions

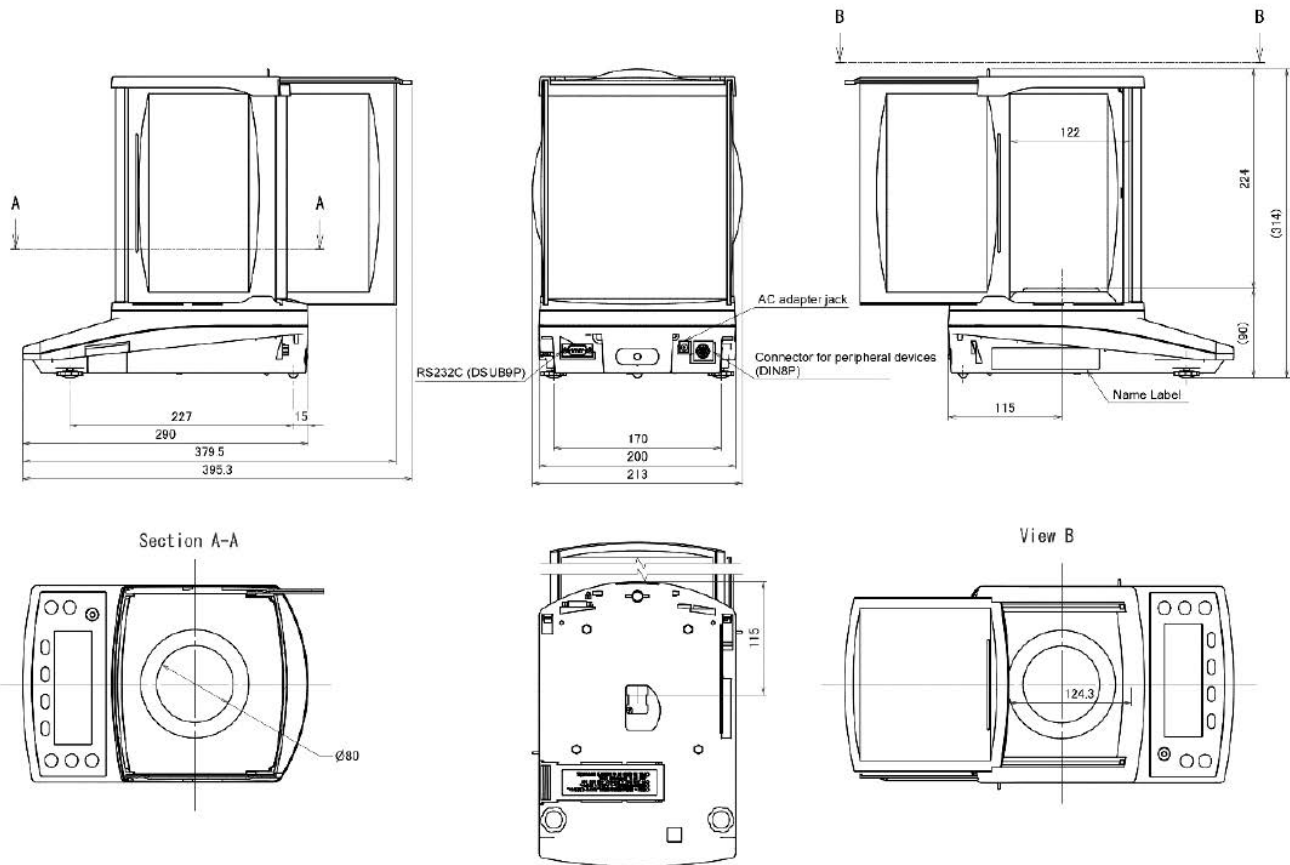

Figure 8-1. TA Plus Model Dimensions (measurements shown in millimeters)

## 8.4 Specifications

### 8.4.1 Basic Communication Specification

#### Transmission System

- Serial transmission, start-stop synchronization
- DSUB9P: bidirectional
- DIN8P: unidirectional from the balance to peripherals

#### Signal level

- Equivalent to EIA RS-232C
- High level (data logic 0) +5 – +15 V
- Low level (data logic 1) -5 – -15 V

#### Baud rate

- 1200/2400/4800/9600/19200 bps

#### Transmission Code Composition

- Start bit . . . . . 1 bit
- Parity bit . . . . . None/Odd number/Even number
- Data bit . . . . . 8 bit
- Stop bit . . . . . 1 bit/2 bit

### 8.4.2 Model Specifications

Model	Max	d	Indication limit	Counting mode minimum unit weight	Percentage mode weight limit	Dimensions of the pan	Span Adjustment
TA Plus -124	12000 mg	0.1	120009.0	0.0001 g	0.01 g	80 mm	External
	120 g	0.0001	120.0090				
	1100 ct	0.0005	600.090				
TA Plus - 224	220000 mg	0.1 mg	220009.0 mg	0.0001 g	0.01 g		
	220 g	0.0001 g	220.0090 g				
	1100 ct	0.001 ct	1100.090 ct				

Table 8-2. Model Specifications

### 8.4.3 Functional Specifications

Item	Description
Weighing System	Tuning fork vibration method
Weighing Modes	Weighing/counting/percentage/multiplied by coefficient/specific gravity modes
Functions	Functions related to the operation — comparator/adding/tare-subtraction reminder/zero-point adjustment reminder/stability waiting/bar graph/backlight/auto power off/simple SCS
	Function related to the performance — stability discrimination width/response speed/zero tracking
	User information settings — preset tare/weight/percentage/counting/multiplied by coefficient/comparator
	Functions related to the lock — total lock release/key lock/menu lock
	Controlling and adjustment functions — shortcut/free key/balance ID/password/output language (English, Japanese)/date and time setting/designation of minimum indication/span adjustment at power on/direct start/initialize
	Other functions that can be assigned to free keys — GLP footer and header output/date indication/time indication/balance ID indication
Display	LCD with backlight 7-segment: maximum 8-digit/segment height up to 16.5 mm 16-segment: maximum 20-digit/segment height up to 8.5 mm Bar graph: 30 steps
Tare range setting	Weight subtraction with the tare key
Zero tracking	Enabled (can be disabled in settings)
Display when overloaded	When the indication limit is exceeded, <OVER ERROR> is indicated.
Output	RS-232C compliant output is equipped as standard (D-sub9P male connector)
Calibration	TA Plus124: semi-automatic/automatic span adjustment/test by internal calibration device semi-automatic span adjustment/test with external weight advice CAL TA Plus 224: semi-automatic span adjustment/test with external weight advice CAL
Power	Dedicated AC adapter (100-240 VAC / 50-60 Hz)
Ratings	AC adapter: 12 VDC 0.9A
Balance weight (net)	2.9 kg
Operating conditions	Temperature: 10-30° C Humidity: 80% or lower (no condensation) Pollution degree: 2 Altitude: 2000m or less above sea level Location of use: indoor
Option	Specific gravity measuring kit

Table 8-3. Functional Specifications

## 9.0 Appendix

Weighing Capacity and Readability by unit.

Unit	Model	
	TA Plus - 124	TA Plus - 224
<b>g</b> gram	120 0.0001	220 0.0001
<b>ct</b> carat	600 0.0005	1100 0.001
<b>lb</b> pound	0.26 0.000001	0.48 0.000001
<b>oz</b> ounce	4.2 0.000005	7.7 0.000005
<b>oz t</b> troy ounce	3.8 0.000005	7 0.000005
<b>GN</b> grain	1800 0.002	3300 0.002
<b>dwt</b> pennyweight	77 0.0001	140 0.0001
<b>mom</b> momme	32 0.00005	58 0.00005
<b>MSG</b> mesghal	26 0.00005	47 0.00005
<b>t : H</b> Hong Kong tael	3.2 0.000005	5.8 0.000005
<b>t : S</b> Singapore/ Maylaysia tael	3.1 0.000005	5.8 0.000005
<b>t : T</b> Taiwan tael	3.2 0.000005	5.8 0.000005
<b>to</b> tola	10 0.00001	18 0.00001
<b>BA t</b> baht	7.9 0.00001	14 0.00001
<b>mg</b> milligram	120000 0.1	220000 0.1

Table 9-1. Weighing Capacity and Readability by Unit







© Rice Lake Weighing Systems Specifications subject to change without notice.  
Rice Lake Weighing Systems is an ISO 9001 registered company.

230 W. Coleman St. • Rice Lake, WI 54868 • USA  
U.S. 800-472-6703 • Canada/Mexico 800-321-6703 • International 715-234-9171 • Europe +31 (0)26 472 1319