

ROCKER COLUMN  
**RLSCA-50K**

Stainless Steel, Welded Seal, NTEP Certified 1:10,000 Class III Multiple Cell, IP67



Picture is a representation of actual product.

Approvals



Order Information

Load Rating	Part #	Est. Weight	Price
50,000 lb*	<b>68918</b>	7 lb	Consult
Replacement Parts			
Replacement load cup set upper and lower included	<b>85433</b>	1 lb	Consult
Replacement O-ring	<b>92988</b>	1 lb	Consult/each

\*Load cell supplied with load cups

Dimensions

Rated Capacity	A	B	C	D	F	H	I	J	K
50,000 lb/in	1.46	7.75	7.25	2.82	1.70	0.50	0.25	1.48	2.50

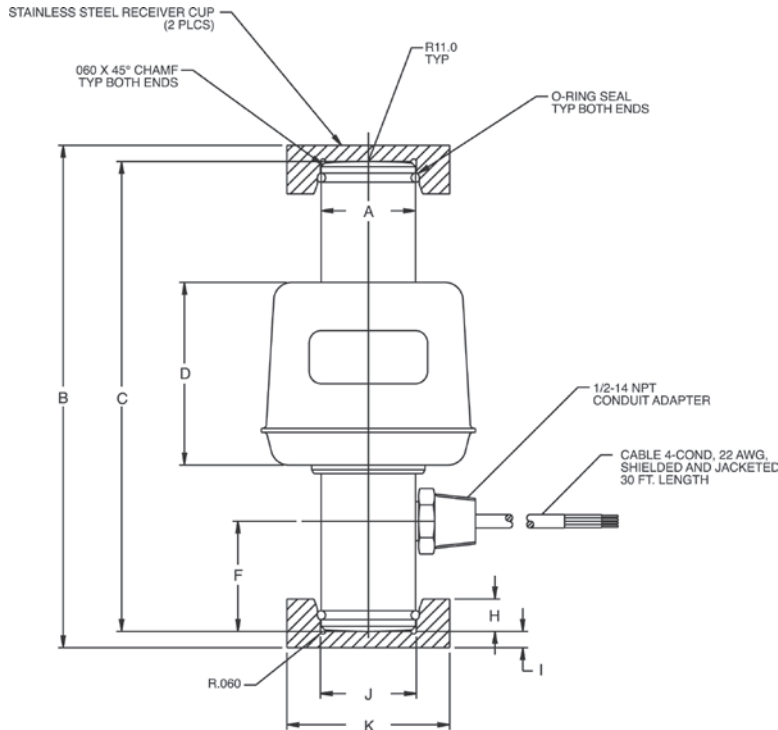

Interchangeable Products

CARDINAL®  
**SCA-50K**

Specifications

- Full Scale Output:**  
2 mV/V nominal
- Output Resistance:**  
1,050 (± 10) ohm
- Input Resistance:**  
1,100 to 1,500 ohm
- Material/Finish:**  
Stainless steel
- Temperature:**  
Compensated range  
14 °F to 104 °F (-10 °C to 40 °C)  
Operating range  
0 °F to 150 °F (-18 °C to 65 °C)
- Seal Type:**  
Welded-seal, IP67
- Safe Overload:**  
150% full scale
- Rated Excitation:**  
5 to 10 VDC (15 V maximum)
- Combined Error:**  
0.025% full scale
- Non-repeatability:**  
0.01% full scale
- Insulation Resistance:**  
1,000 megohm
- Cable Length:**  
30 ft
- Cable Diameter:**  
0.200 in  
Polyurethane jacket
- Cable Color Code:**  
Green +Excitation  
Black -Excitation  
Red +Signal  
White -Signal
- Warranty:**  
Two-year limited
- Approvals:**  
NTEP 01-073  
cFMus

RICE LAKE  
LOAD CELLS