

Load Ranger

*Bluetooth® Communication
Wheel Weigh Pad System*

Technical Manual



© Rice Lake Weighing Systems. All rights reserved.

Rice Lake Weighing Systems® is a registered trademark of
Rice Lake Weighing Systems.

All other brand or product names within this publication are trademarks or
registered trademarks of their respective companies.

All information contained within this publication is, to the best of our knowledge, complete and
accurate at the time of publication. Rice Lake Weighing Systems reserves the right to make
changes to the technology, features, specifications and design of the equipment without notice.

The most current version of this publication, software, firmware and all other product
updates can be found on our website:

www.ricelake.com

Revision History

This section tracks and describes the current and previous manual revisions for awareness of major updates and when the updates took place.

Revision	Date	Description
-	August 09, 2018	Initial manual release with the launch of the product
D	July 22, 2022	Revision history established after Rev C

Table i. Revision Letter History



Technical training seminars are available through Rice Lake Weighing Systems. Course descriptions and dates can be viewed at www.ricelake.com/training or obtained by calling 715-234-9171 and asking for the training department.

Contents

1.0 Introduction	1
1.1 Safety	1
1.2 FCC Compliance	2
1.3 Available Models	2
1.4 Features	2
1.5 Accessories	4
2.0 Installation	5
2.1 Choosing the Weighing Area	5
2.2 Positioning the Platforms	5
2.3 Correct Platform Use	7
2.4 Applications	7
2.4.1 Wireless Setup	7
2.4.2 Wired Setup	10
2.4.3 Hybrid Wireless Setup	11
2.5 Weighing of Objects or Structures	13
3.0 Setup and Operation	14
3.1 Weigh Pad Display	14
3.1.1 Key Functions	14
3.1.2 Display Features	15
3.1.3 Assign ID Numbers and Initialize Bluetooth	15
3.2 Ai-1 Indicator Display	16
3.2.1 Pairing Ai-1 Indicator with Weigh Pads	17
3.3 Standard Ai-1 Indicator Functions	20
3.3.1 Zeroing Weigh Pads with Indicator	20
3.3.2 Tare Options	20
3.4 Weighing Procedure	21
3.4.1 Wheel-Weighing System	21
3.4.2 Axle-Weighing System	21
3.5 Battery Recharging	22
3.6 Input Texts	23
3.7 Vehicle Database	23
3.7.1 Create Vehicle	23
3.7.2 Modify Vehicle	24
3.7.3 Delete Vehicle	24
3.7.4 Select Vehicle on Primary Weigh Screen	24
3.7.5 Deselect Vehicle on Primary Weigh Screen	24
3.7.6 Temporary Vehicle	25
3.7.7 Alphanumeric Search	25
3.7.8 Index Search	25
3.8 Print Formats	26
3.8.1 Default Print Formats	27
3.9 Setpoints	29
3.9.1 Change Setpoint Functions	29
4.0 Configuration	30
4.1 Weigh Pad Technical Menu	30



Rice Lake continually offers web-based video training on a growing selection of product-related topics at no cost. Visit www.ricelake.com/webinars

4.1.1	Keyboard Lock	31
4.1.2	Default Weigh Pad	31
4.1.3	Weigh Pad Metrological Configuration	32
4.1.4	View Weigh Pad Metrological	32
4.1.5	Overload Range	33
4.1.6	Unit Conversion	33
4.2	Indicator Technical Setup Menu	34
4.2.1	Configure Touch Display	35
4.2.2	Date and Time	35
4.2.3	Date and Time Password	35
4.2.4	Printout Headings	35
4.2.5	Shortcuts	35
4.3	Center of Gravity	36
4.3.1	Center of Gravity Units	36
4.3.2	Indicator Metrological Configuration	37
4.3.3	Overload Range	37
5.0	Calibration	38
5.1	Calibrate with Wheel Weigh Pad Display	38
5.1.1	Complete Calibration Procedure	38
5.1.2	Zero Calibration Procedure	39
5.2	Calibrate with Ai-1 Indicator	39
5.2.1	Standard Calibration	39
5.2.2	Zero Calibration	40
6.0	Maintenance	41
6.1	Operation Check	41
6.2	Maintenance and Cleaning	41
6.3	Accessory Assembly	42
6.3.1	Display Cover	42
6.3.2	Transport Wheels	42
6.3.3	Aluminum Ramps	43
6.4	Board Diagram	44
6.5	Wiring Schemes	45
6.5.1	Load Cell Wiring	45
6.5.2	Power Supply Wiring	46
6.5.3	RS485 Wiring	47
6.5.4	Bluetooth Connection	48
6.6	Calibration Jumper	49
6.7	Messages and Errors	49
6.7.1	Programming Errors	49
6.8	Frequently Asked Questions	50
7.0	Appendix	51
7.1	Wheel Weigh Pad (RF-MD, RF-WD, RF-XWD) Dimensions	51
7.2	Replacement Parts	52
7.2.1	Wheel Weigh Pad (RF-MD, RF-WD, RF-XWD) Replacement Parts	52
7.2.2	Load Ranger Ai-1 Replacement Parts	53
7.3	Replacement Load Cells	54
8.0	Compliance	55



Technical training seminars are available through Rice Lake Weighing Systems. Course descriptions and dates can be viewed at www.ricelake.com/training or obtained by calling 715-234-9171 and asking for the training department.

9.0 Specifications 57



Rice Lake continually offers web-based video training on a growing selection of product-related topics at no cost. Visit www.ricelake.com/webinars

1.0 Introduction

Load Ranger wheel weigh pads offer an adaptable, high accuracy solution for vehicle weighing. With unmatched performance, Load Ranger wireless weigh pads are able to capture wheel or axle weights, either individually or in sets of up to 14 pads. Besides vehicles, Load Ranger wheel weigh pads can weigh objects and structures with several support points of an array of sizes and capacities. Load Ranger wheel weigh pads can be paired with the Ai-1 touchscreen indicator and thermal printer to provide an all-in-one solution for weight summing and ticket printing.



Manuals and additional resources are available from Rice Lake Weighing Systems at www.ricelake.com/manuals

Warranty information can be found at www.ricelake.com/warranties

1.1 Safety

Safety Definitions:



DANGER: Indicates an imminently hazardous situation that, if not avoided, will result in death or serious injury. Includes hazards that are exposed when guards are removed.



WARNING: Indicates a potentially hazardous situation that, if not avoided, could result in serious injury or death. Includes hazards that are exposed when guards are removed.



CAUTION: Indicates a potentially hazardous situation that, if not avoided, could result in minor or moderate injury.



IMPORTANT: Indicates information about procedures that, if not observed, could result in damage to equipment or corruption to and loss of data.

General Safety



Do not operate or work on this equipment unless this manual has been read and all instructions are understood. Failure to follow the instructions or heed the warnings could result in injury or death. Contact any Rice Lake Weighing Systems dealer for replacement manuals.



WARNING

Failure to heed could result in serious injury or death.

Do not disassemble or tamper with the platforms.

All connections must be made by following applicable standards in the installation area and environment.

Do not install in environments at risk of explosion (except for specific versions).

Do not allow minors (children) or inexperienced persons to operate this equipment.

Ensure the pads and path to enter them is clear of all people and equipment.

Do not overload the platforms beyond the maximum declared load.

Do not use solvents or aggressive substances to clean the platform or weight indicator.

Do not pour liquids on the weight indicator.

Avoid prolonged exposure to atmospheric agents (sun, rain, etc.).

Do not expose the instrument to heat sources.

Do not lean platforms against a wall or object. Always lay platforms flat on the ground.

Always place or anchor the weight indicator and platform on a non-vibrating surface.

Anything not specifically described in this manual is to be considered as improper use of the equipment.

All of the indicator connections must be in accordance with applicable local and state laws within the installation environment.

1.2 FCC Compliance

United States

This equipment has been tested and found to comply with the limits for a Class A digital device, pursuant to Part 15 of the FCC Rules. These limits are designed to provide reasonable protection against harmful interference when the equipment is operated in a commercial environment. This equipment generates, uses and can radiate radio frequency energy and, if not installed and used in accordance with the instruction manual, may cause harmful interference to radio communications. Operation of this equipment in a residential area is likely to cause harmful interference in which case the user will be required to correct the interference at his own expense.

Canada

This digital apparatus does not exceed the Class A limits for radio noise emissions from digital apparatus set out in the Radio Interference Regulations of the Canadian Department of Communications.

Le présent appareil numérique n'émet pas de bruits radioélectriques dépassant les limites applicables aux appareils numériques de la Class A prescrites dans le Règlement sur le brouillage radioélectrique édicté par le ministère des Communications du Canada.

1.3 Available Models

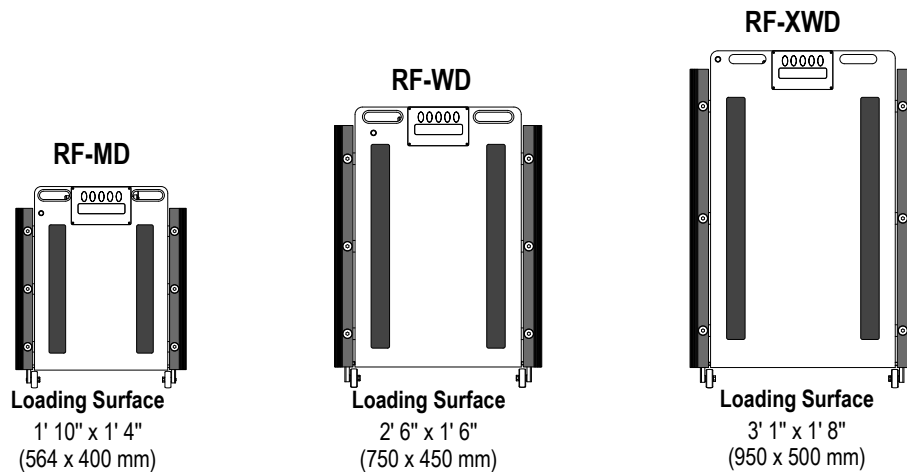

1.4 Features

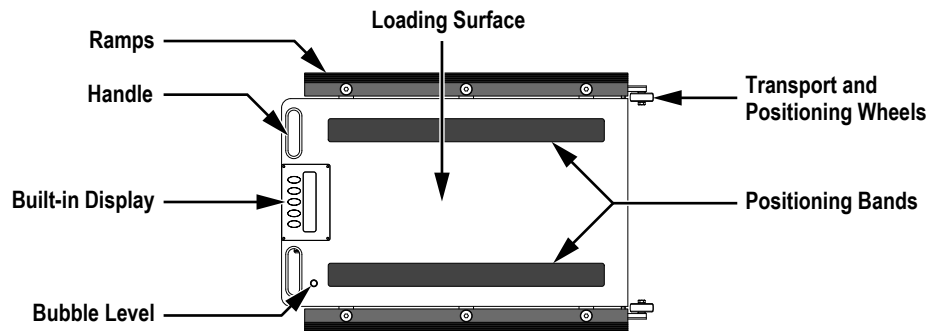

Wheel Weigh Pad Features

- Equipped with an industrial Bluetooth® radio module for ability to communicate with Ai-1 indicator
- Special aluminum alloy loading platform with positioning bands and bubble level
- Integrated wheels and handles for easier transport and positioning
- Built-in ramps with non-slip rubber on the undersides for good grip on all types of surfaces
- Cover plate provides protection of the display and buttons
- Internal NiMH rechargeable battery with 40 hours of battery life
- UL approved external battery charger
- IP67 overall protection rating with watertight connections

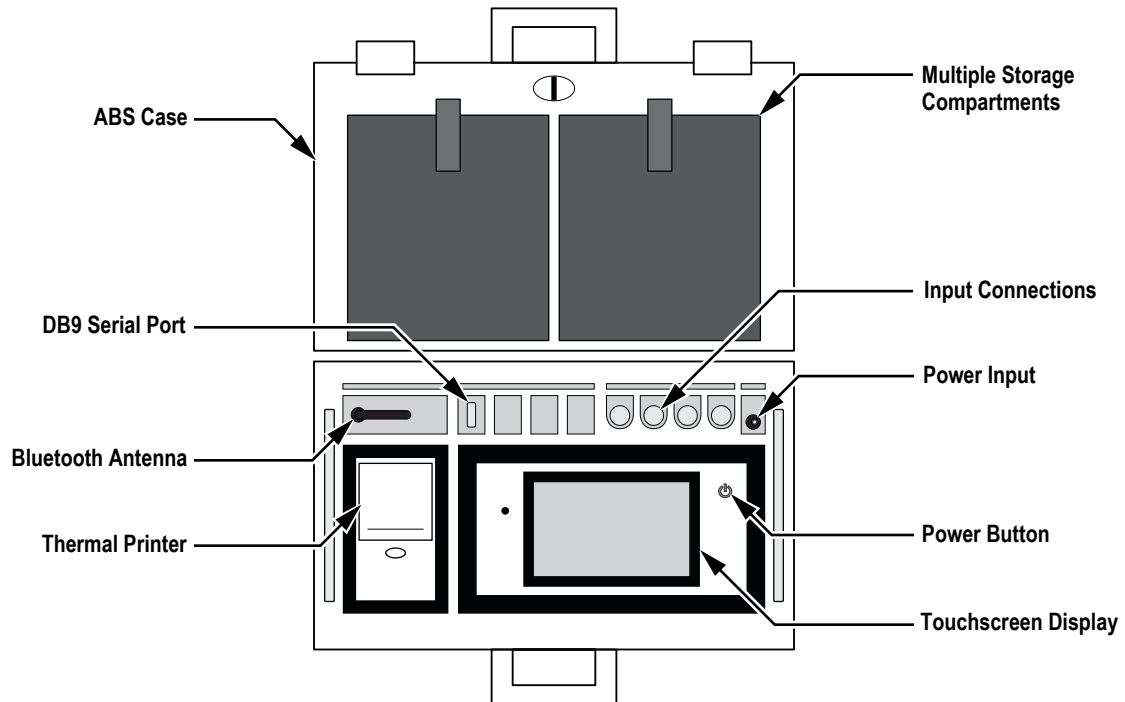

Ai-1 Indicator Features

- ABS transport case – 1' x 1' 6" x 7" (325 mm x 460 mm x 170 mm)
- Backlit graphic display with touchscreen technology
- Internal rechargeable battery with 10 hours of battery life
- Thermal printer
- Real time clock
- Permanent data storage
- Slot for micro SD card
- 24-bit A/D converter, up to 2300 conversions per second
- DB9 RS232 serial port

1.5 Accessories

Aluminum Ramps

The optional aluminum ramps are used to make it easier for a wheel to move onto and off of the platform. This is ideal for vehicles with small diameter wheels or for vehicles/aircraft moved with towing equipment.



Part No.	Description
181881	Aluminum Ramp for Load Ranger MD Models
181882	Aluminum Ramp for Load Ranger WD Models
181883	Aluminum Ramp for Load Ranger XWD Models

Table 1-1. Available Accessories

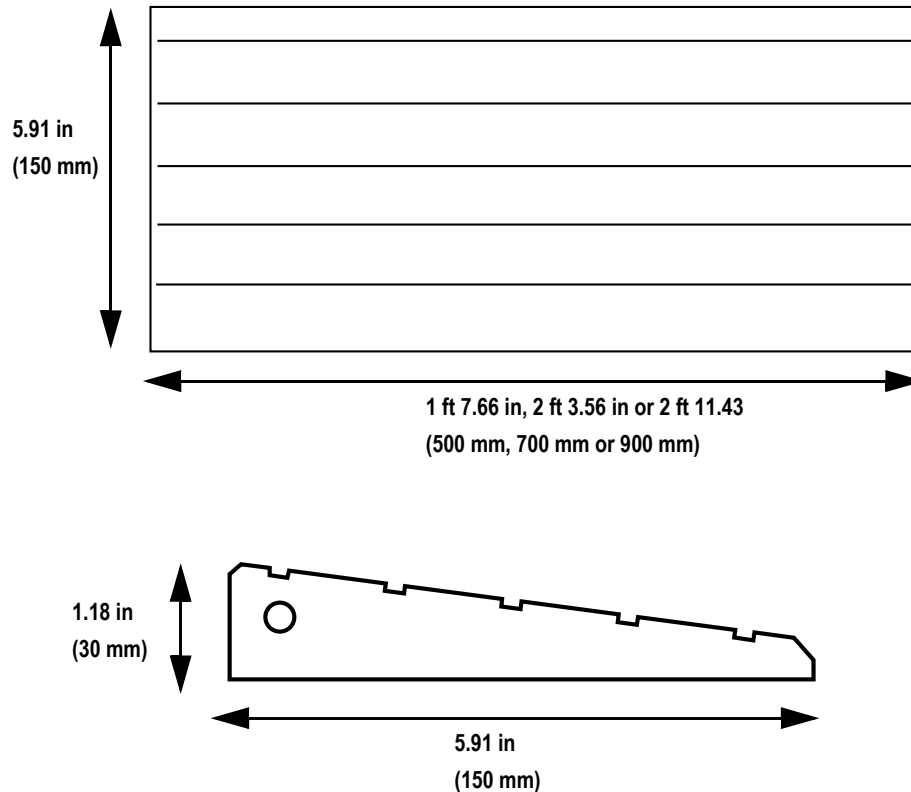

Figure 1-1. Aluminum Ramp Dimensions

2.0 Installation

Follow the procedures in the section to setup a Load Ranger system.

2.1 Choosing the Weighing Area

Load Ranger wheel weigh pads can be installed on most types of surfaces. For the best results, Rice Lake Weighing Systems recommends:

- An area that is large enough to allow vehicles to easily maneuver under safe conditions
- A minimum length twice that of the longest vehicle to be weighed
- Flat and level surfaces with a slope of less than 0.5%
- Use on hard surfaces, concrete or asphalt with a hardness of at least 1423 lb/in² (100 kg/cm²)
- The surface under the weighing area must withstand concentrated loads of at least 1.5 times the maximum capacity of the wheel weigh pad
- Environments where the temperature is between 14°F and 104°F (-10°C and 40°C)
- Always use the same direction of travel



IMPORTANT: Weighing area recommendations are important for accurate weighing and to avoid damage to the weigh pads. Avoid areas at risk of flooding and areas used for common transit. The wheel weigh pads are not designed to be used as road surfaces and must only be used at the time of weighing according to the conditions stated in [Section 2.3 on page 7](#).

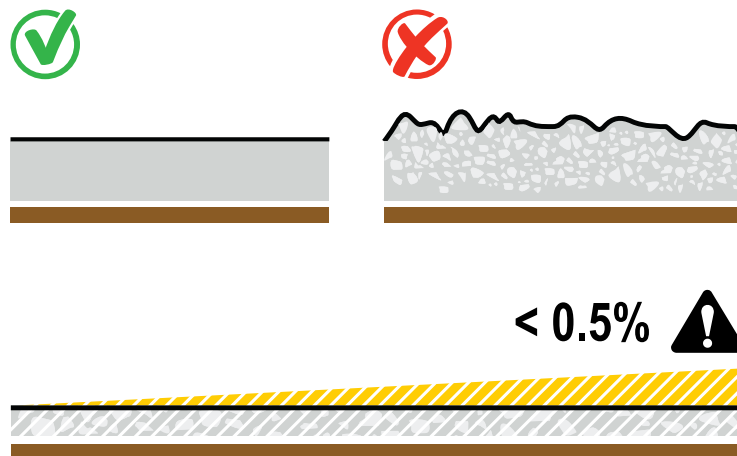
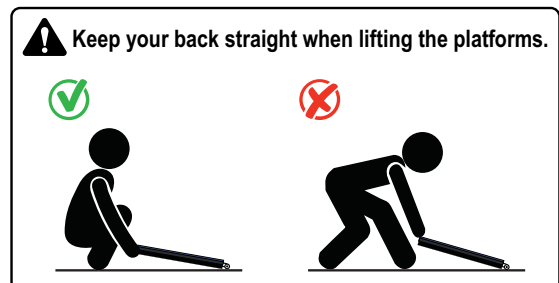
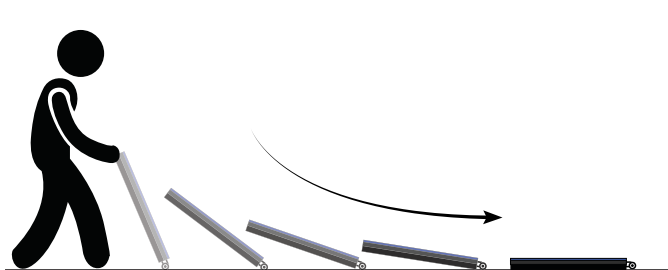

Figure 2-1. Weighing Area Characteristics

2.2 Positioning the Platforms

1. Use the built-in wheels to position and adjust the platforms.



2. Position the platforms directly in front of the wheels of the vehicle to be weighed.

1.



2.

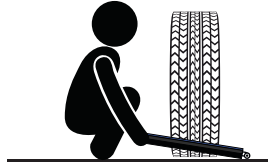

3.



CAUTION: Do not place hands or feet under the platform when positioning them. Wear protective gloves and shoes when installing the wheel weigh pad.

3. The display must be facing outwards in order to correctly transmit the wireless weighing data.

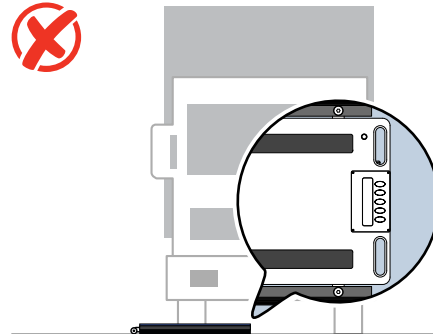
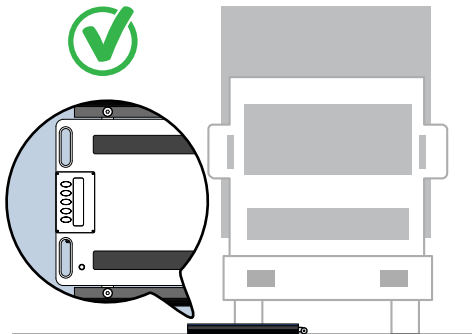

WARNING: Before positioning the platforms, ensure that the vehicle's engine is off, with the first gear engaged and the parking brake activated.

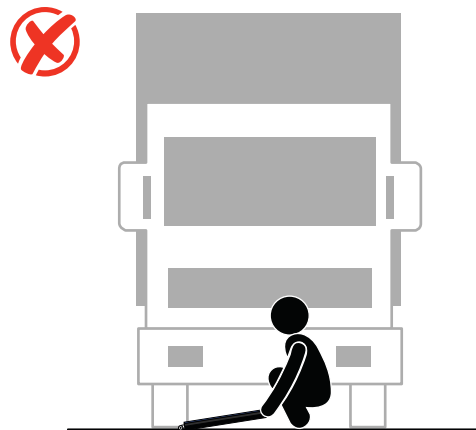
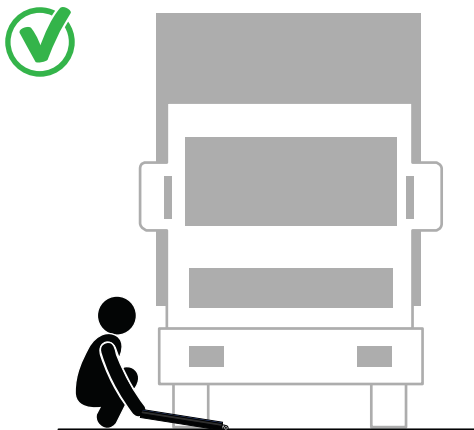

WARNING: Only position platforms when the vehicle is stopped. Never stand in front or behind the vehicle when positioning the platforms.

2.3 Correct Platform Use

Refer to the transit area and the positioning bands for the proper transit path and weighing location.

 **Avoid transit over the display to preserve correct operation and to prevent accidental scratches.**

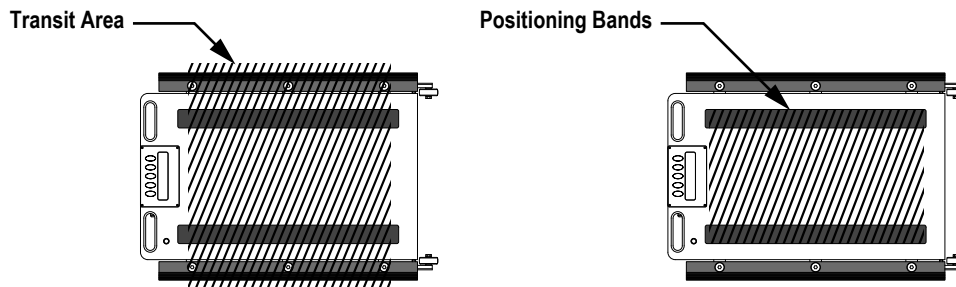

Always position the wheel weigh pads so the transit path onto and off of the platform fully utilizes the ramps.

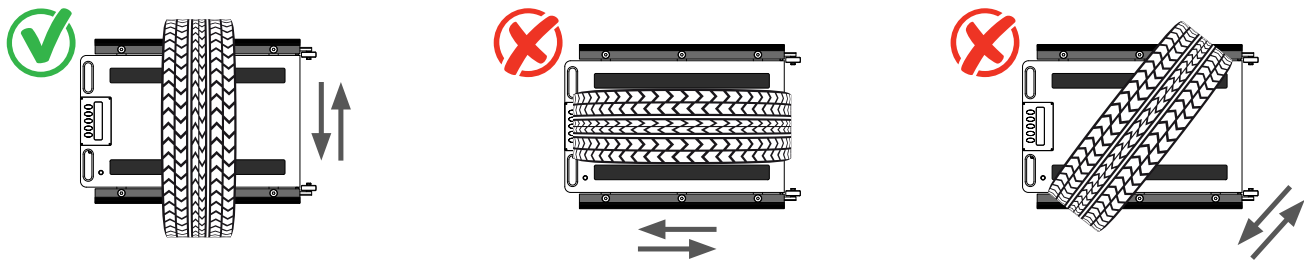

 **IMPORTANT: Failure to heed the following could result in equipment damage.**

- Do not weigh vehicles carrying liquids when using an axle-weighing system.
- The type and maintenance state of the vehicle being weighed can effect the weighing performance.
- Always keep the same direction of travel once the system has been optimized.

2.4 Applications

The Load Ranger weigh pads can be arranged to serve multiple applications. The adjustment from one scenario to another is made quickly and easily with the wireless and portability features of the Load Ranger system. This section highlights several of the arrangements available.

2.4.1 Wireless Setup

A wireless system allows for weighing with up to seven connected wheel weigh pads.

Two Platforms

Applications include weighing axles of the vehicle individually or trailers with only one axle.

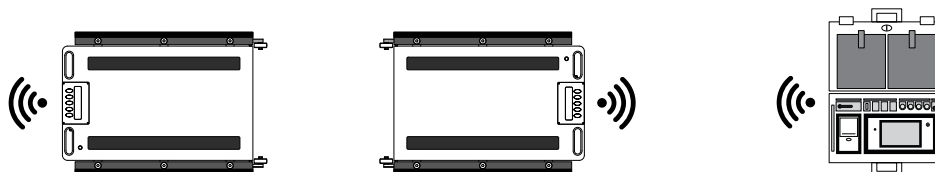

Three Platforms

Applications include weighing small planes, three-wheeled vehicles or trailers with a support pin.

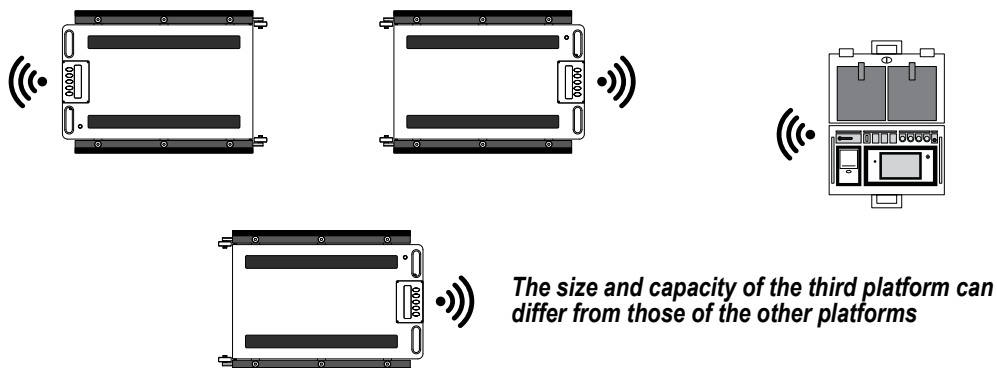

Four Platforms

Applications include weighing two-axle vehicles, trailers, containers or other items with four support points.

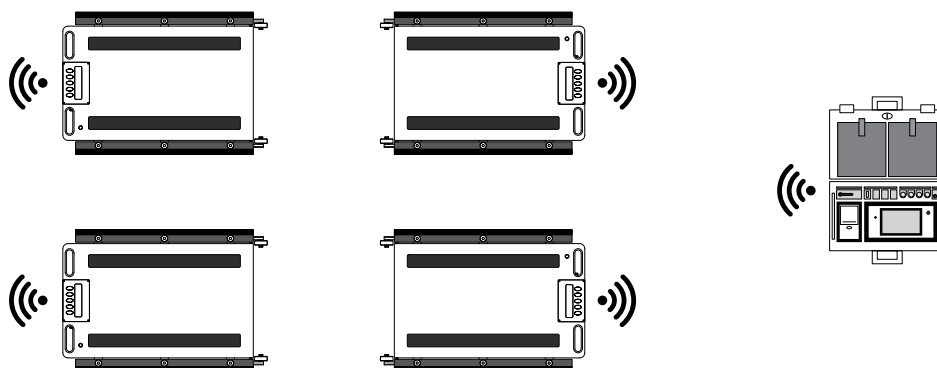

Five Platforms

Applications include weighing two-axle trailers with a support pin. When weighing both directions, a sixth platform can be used.

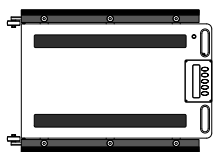

The size and capacity of the fifth platform can differ from those of the other platforms

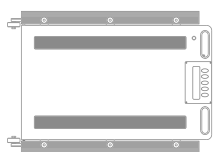
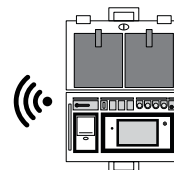
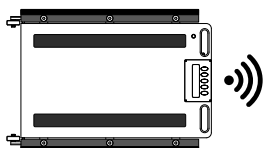
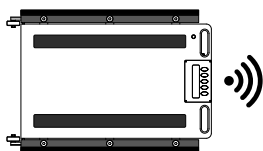
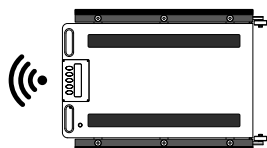
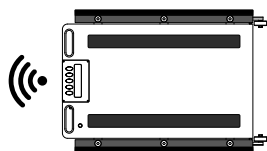

Optional sixth platform

Six Platforms

Applications include weighing three-axle vehicles or structures with six support points.

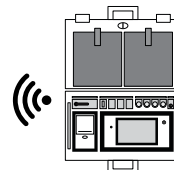
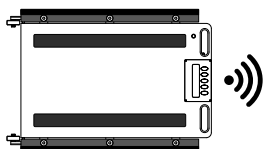
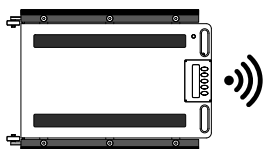
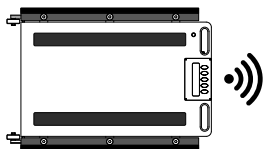
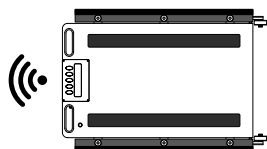
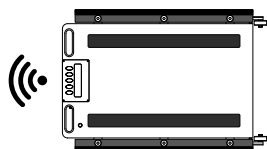
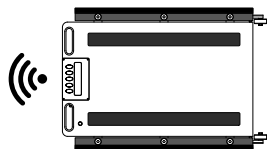

Connection Procedure

1. Assign ID numbers to the weigh pads and initialize Bluetooth ([Section 3.1.3 on page 15](#)).
2. Pair the Ai-1 indicator with the weigh pads ([Section 3.2.1 on page 17](#)).
3. Turn off the weigh pads and the Ai-1 indicator.
4. Connect RS485 cables to the weigh pads data communication ports.
5. Connect the other ends of each RS485 cable to one of the Ai-1 indicator communication ports.

 **NOTE:** The wheel weigh pads can be connected to any of the RS485 ports on the Ai-1 indicator. The pad ID assigned within the weigh pad dictates the scale number and it does not need to match the Ai-1 indicator channel number.

6. Turn on all of the weigh pads.
7. Turn on the Ai-1 indicator. *485 H* briefly displays on weigh pads (*H* represents the assigned pad ID number). *PL.H* then displays on the weigh pads and they are ready for use.

2.4.2 Wired Setup

A wired system allows for weighing with two to four connected wheel weigh pads.

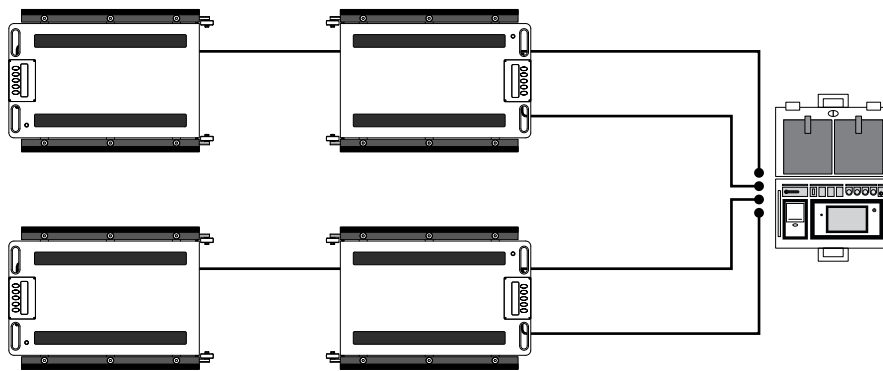

Figure 2-2. Recommend Cable Placement

The data communication port is located on the underside of the wheel weigh pad. For the RF-MD the port is located at the handle end of the platform and is the port further from the edge. For the RF-WD and RF-XWD the port is located at the end opposite of the platform handles.

 **NOTE:** The data communication port uses a 5-pin connector and the power connection port uses a 4-pin connector. No parameters need to be changes to switch from a Bluetooth to an RS485 connection.

Cable Positions

 **IMPORTANT:** Do not pass cables in transit areas, under the load cells or under the central box of the platform.

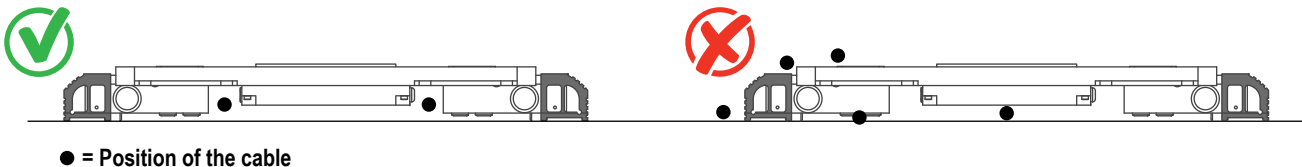

2.4.3 Hybrid Wireless Setup

A hybrid system allows for weighing up to 14 connected wheel weigh pads.

A hybrid wireless system allows for the weighing of vehicles with four to seven axles. These larger applications are possible by connecting each axle set of weigh pads together with a cable, so that one weigh pad is able to transfer both sets of weigh data wirelessly to the indicator.

Eight to Fourteen Platforms



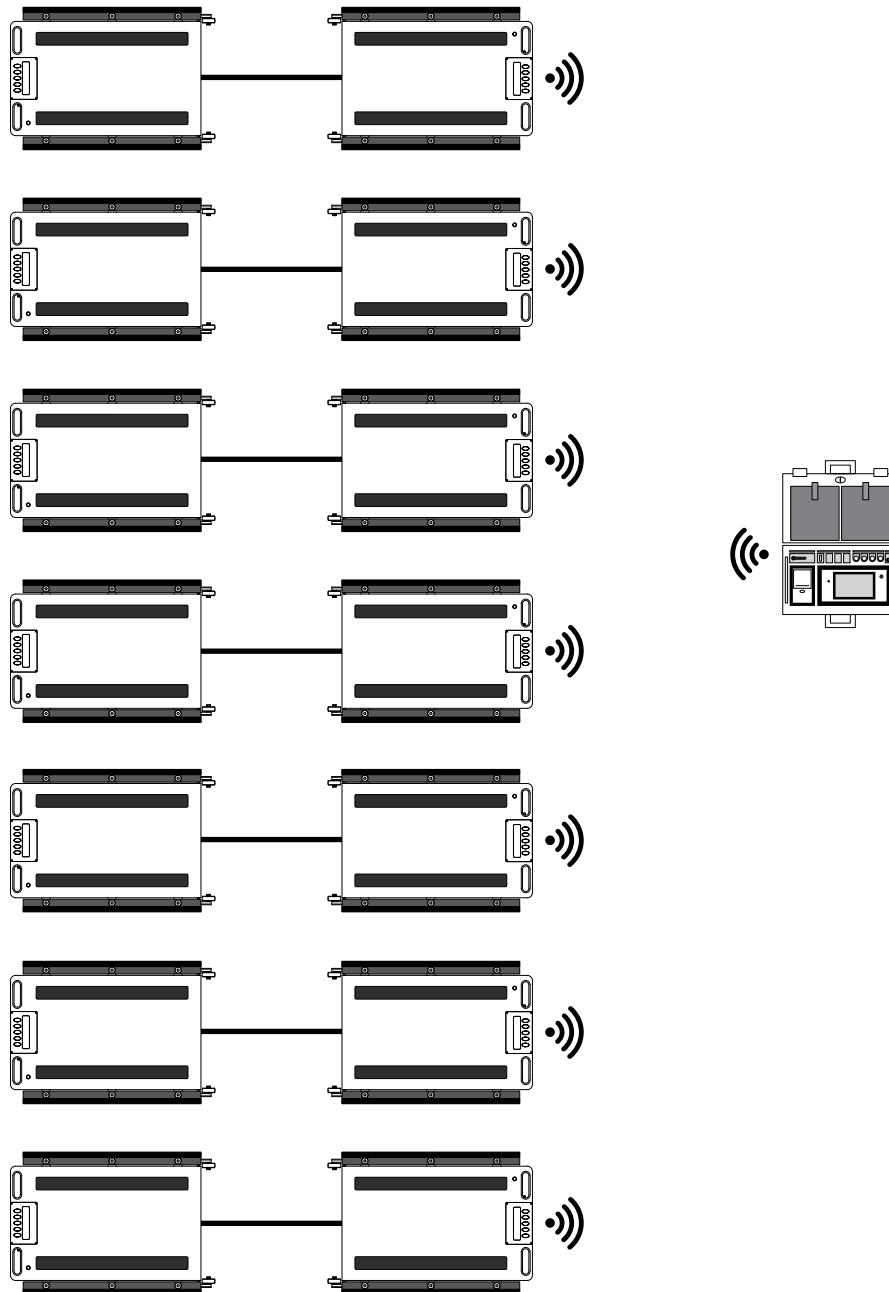













Applications include weighing multi-axle vehicles or structures with several support points in a single step.



NOTE: Seven wireless and seven wired wheel weigh pads can be connected together for a total of 14 wheel weigh pads.













Hybrid Configuration

For hybrid configuration of pads to the indicator, see the following procedure.

1. Wire and assign IDs to each wheel weigh pad in pairs of two (1-2, 3-4, 5-6...13-14).
2. Disable Bluetooth on the even wheel weigh pads (2, 4, 6...14) (Table 4-1 on page 30).
 - a. Press  to power on the even wheel weigh pads (2, 4, 6...14) then press  during startup. *LECH* flashes then *LRAL* displays.
 - b. Press  or  until *ADUANC* displays then press  (Table 4-1 on page 30). *CAL.PAR* displays..
 - c. Press  or  until *P in. USE* displays then press  (Table 4-1 on page 30). *YES* displays.
 - d. Press  until *n0* displays then press .
 - e. Press  twice. *SETORP* displays.
 - f. Press  to enter **Weigh** mode then press , *bt. 0n* displays.
 - g. Press  or  until *bt. OFF* displays then press .



IMPORTANT: Disable Bluetooth for each of the wireless even numbered wheel weigh pads (2, 4, 6...14). Do not disable Bluetooth for the odd numbered wheel weigh pads (1, 3, 5...13).

3. Power off each of the odd numbered wheel weigh pads (1, 3, 5...13).
4. Press  to power on the Ai-1 indicator.
5. During Ai-1 indicator startup press the upper right corner of the screen when the logo displays to enter the **Technical Setup** menu Section 4.2 on page 34.
6. Press  or  to navigate to the **Calibration** menu. *LRAL* displays (Section 5.2 on page 39).
7. Select **Scale Selection** then edit the number of scales on the indicator to equal the number of total wheel weigh pads.
8. Navigate to the **WWS Configuration** menu.
9. Select **WWS** pairing then press **Pair** to begin pairing.
 - a. Press  to power on the odd wheel weigh pads (1, 3, 5...13) then press  during startup. *LECH* flashes, then *LRAL* displays.
 - b. Press  three times. *SER LRAL* displays.
 - c. Press  to enter the **Serial** menu.
 - d. Press  or  until *bt. in it* displays then press .
 - e. Press  to enter the **Bluetooth Initialization** menu. *bt. in it* displays.
 - f. Press  to confirm. This will send a Bluetooth pairing signal (Table 4-1 on page 30). Repeat as necessary until both pair ID's are shown on the indicator.
 - g. Repeat **Step a** – **Step d** for each odd numbered wheel weigh pad, in numeric order.



NOTE: When an odd wheel weigh pad is paired, the even wheel weigh pad assigned to it automatically pairs (Step 1). A Bluetooth signal is sent to pair devices. The devices must be connected within 20-seconds. If the devices are not connected within 20-seconds another *bt. in it* must be sent.





Failure to send a Bluetooth pairing signal indicates damaged hardware.

10. On the indicator, press , then press  to save changes. Indicator restarts and returns to the weigh screen.



NOTE: Calibrate as necessary (Section 5.0 on page 38). For first time setup, calibration is required.

11. For each odd number ID wheel weigh pad, after paired, press  until *SETORP* displays then press .
12. The Ai-1 indicator boots to **Weigh** mode. The pads zero out then the weight displays.

2.5 Weighing of Objects or Structures

The Load Ranger weigh pads can be moved in any position directly below the point in which the structure must be weighed. Follow the weighing procedure below to weigh objects or structures correctly.



NOTE: Avoid sharp maneuvers, rapidly lowering the load and accidental crashes into or onto the weigh pads.

Weighing Procedure

1. Lower the load down to an approximate height of 4" (10 cm) from the ground.

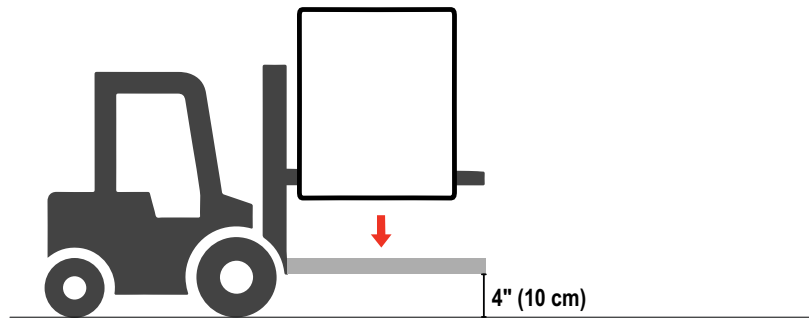

2. Position the load over the platforms.

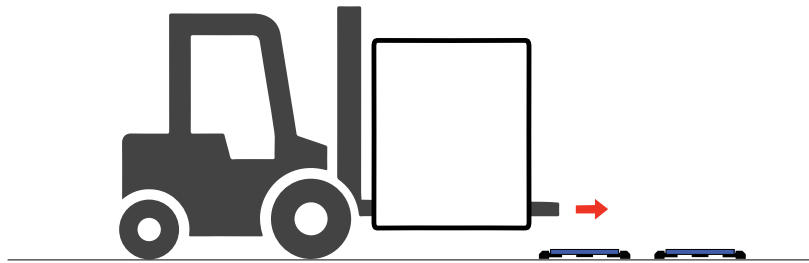

3. Place the load slowly onto the platforms.



IMPORTANT: Do not set the load on the weigh pad display. Always position the displays of the platforms towards the outside of the structure being weighed in order to correctly transmit the weight reading data.

3.0 Setup and Operation

The Load Ranger wheel weigh pads can be operated independently or with an Ai-1 indicator. The following section provides an overview and procedures for both types of applications.

3.1 Weigh Pad Display

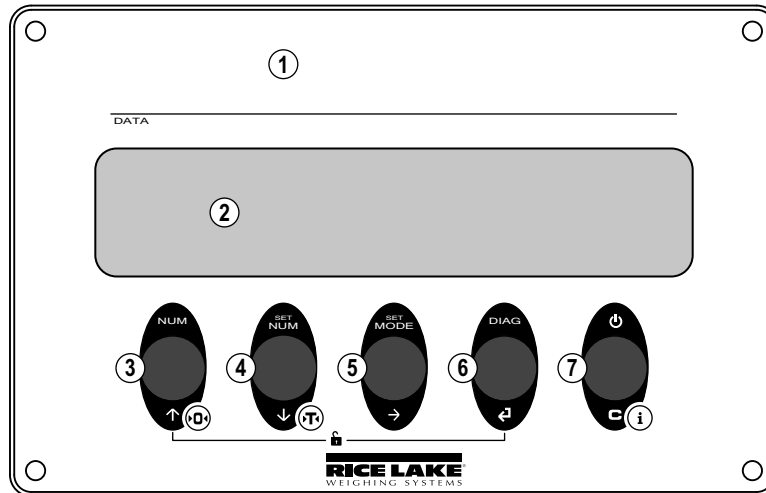

Figure 3-1. Wheel Weigh Pad Display with Cover

Item No.	Description
1	Model label location (an identical label is located on the underside of the platform)
2	Display – Six digit display; 1" characters
3	NUM – Toggles between weight and ID number; functions as a Zero key; used as an Up arrow to navigate menus or to edit a value
4	SET NUM – Display and edit pin number; functions as a Tare key; used as a Down arrow to navigate menus or to edit a value
5	SET MODE – Displays pin number and Bluetooth status; functions as a x10 multiplier; used as a Right arrow to edit a value
6	DIAG – Displays diagnosis and initiates a key test; used as an Enter key to accept an entry at a prompt or when editing a value
7	Power – Turns display on/off; displays wheel weigh pad information; used as Cancel within the menu structure

Table 3-1. Wheel Weigh Pad Keys

3.1.1 Key Functions

- Press to turn on the weigh pad display.
- Press and hold until `-OFF-` displays to turn off the weigh pad display.
- Press and hold until `INFO` displays to scroll through the weigh pad information (2 displays after `-OFF-`).
- Press to display the current platform ID number of the weigh pad.
- Press and hold until `ZERO` displays to zero the weight within 2% of the maximum capacity.
- Press to display and edit the current pin number associated with the weigh pad.
- Press and hold until `TARE` displays to tare the current weight on the weigh pad.
- Press to display the pin number and Bluetooth status of the weigh pad.
- Press and hold to turn a x10 multiplier on and off.
- Press to display a diagnosis of the current mode and to test each key by pressing each one when prompted.
- If the automatic key-lock is active, press then , to unlock the keypad.

3.1.2 Display Features

The weigh pad displays the current weight on the platform and applicable annunciators. When paired with the Ai-1 indicator, a weigh pad displays the assigned platform ID number (PLX) instead of the weight.

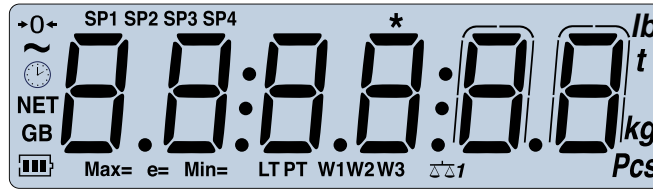

Figure 3-2. Weigh Pad Display



NOTE: Internal battery charge level:



Fully charged



Medium charge



Low charge

Low battery displays prior to the instrument automatically switching off.

Ensure to charge the battery for at least 12 hours with the supplied charger after initial startup.



Unstable weight indicator.



Zero weight indicator.

3.1.3 Assign ID Numbers and Initialize Bluetooth

1. Press **C** to turn on the wheel weigh pad.
2. Press **↓** during startup. *LECh* flashes, then *CAL* displays.
3. Press **↓** three times. *SEr AL* displays.
4. Press **↶** to enter the **Serial** menu. *id* displays.
5. Press **↶** to enter the ID settings.
6. Press **↑** or **↓** to increase or decrease the selected digit and press **→** to move between the digits to enter the pad ID number.



NOTE: The first Pad ID number must be 01 and the remaining pad ID numbers must increment in ascending numeric order. Example: 01, 02, 03. Do not configure two pads with the same ID number. See [Figure 3-3](#) for number positioning.

7. Press **↶** to confirm. *bt . in it* displays.
8. Press **↶** to enter the **Bluetooth Initialization** menu. *bt . in i²* displays.
9. Press **↶** to confirm. *BA it* displays followed by *bt on . on . bt* displays.
10. Press **C** twice. *SAVEP* displays.
11. Press **↶** to confirm. *StorE* briefly displays and all the changed parameters are saved.
12. Repeat steps for all wheel weigh pads in the system.

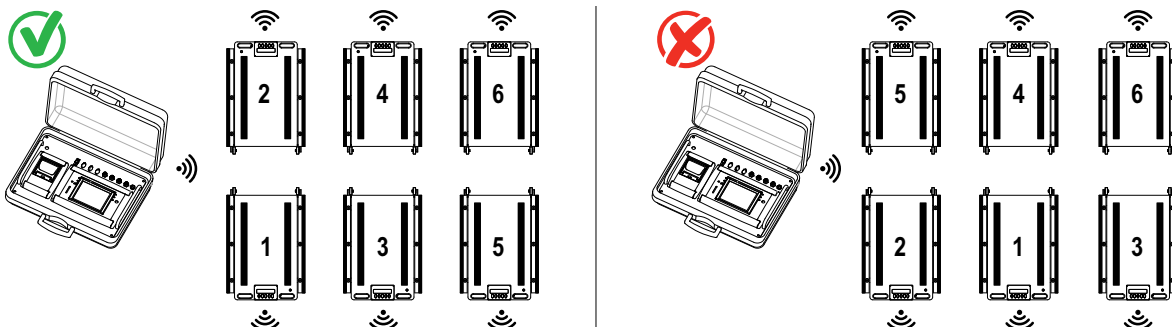

Figure 3-3. Wheel Weigh Pad Positioning

3.2 Ai-1 Indicator Display

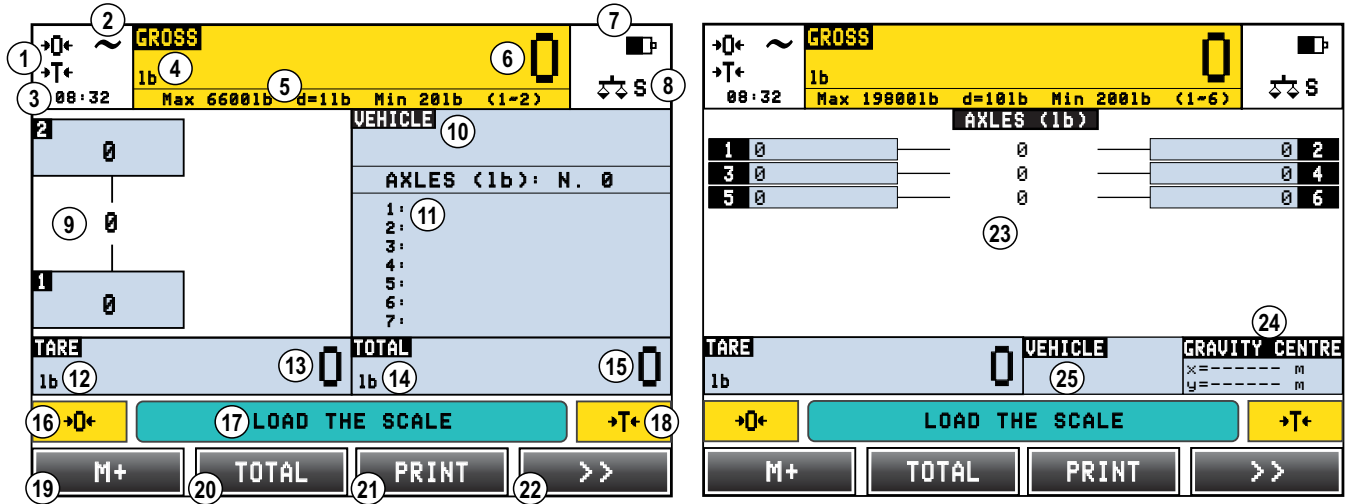

Figure 3-4. Ai-1 Indicator – Primary Weigh Screens

Item No.	Description
Axle-Weighing Primary Weigh Screen	
1	Zero and tare annunciators
2	Unstable annunciator
3	Time – Press within cell to adjust the date and time
4	Gross weight cell – Press within cell to make full screen and press again to return; Gross weight unit annunciator displays
5	Scale information
6	Gross weight value
7	Battery annunciator; plug annunciator displays when indicator is charging
8	Scale annunciator – S = whole scale weight displayed, 1 = platform ID 1 weight displayed, 2 = platform ID 2 weight displayed, etc.
9	Wheel and axle weight display cell – Only displays two axles at a time; Press within cell to select platforms for scale
10	Vehicle cell – Press within cell to select a vehicle
11	Axles cell – Displays total weight of each axle
12	Tare weight cell – Press within cell to manually enter a tare weight; tare weight unit annunciator displays
13	Tare weight value
14	Total weight cell – Total weight unit annunciator displays
15	Total weight value
16	Zero key – Press to zero based on the scale annunciator
17	Indicator message
18	Tare key – Press to tare the current weight of all weigh pads; scale annunciator must be on S (whole scale weight displayed)
19	Programmable key 1 – Set to M+ by default
20	Programmable key 2 – Set to Total by default
21	Programmable key 3 – Set to Print by default
22	Programmable key 4 – Set to More by default
Wheel-Weighing Primary Weigh Screen	
23	Wheel and axle weight display cell – Displays all connected weigh pads; press within cell to select platforms for scale
24	Center of gravity cell – See Section 4.3 on page 36
25	Vehicle cell – Press within cell to select a vehicle

Table 3-2. Ai-1 Indicator – Primary Weigh Screen Descriptions

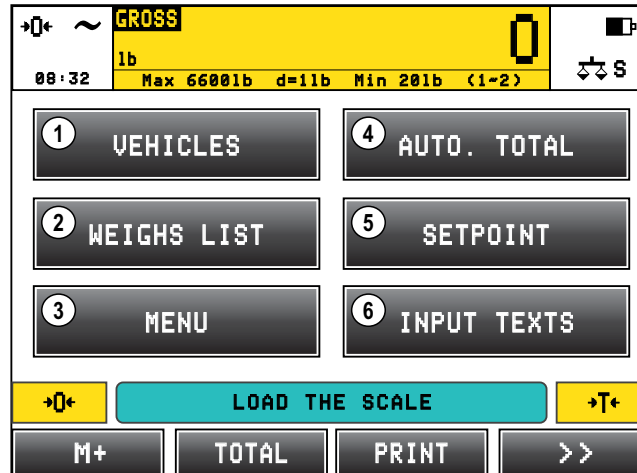

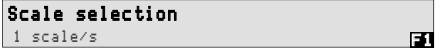

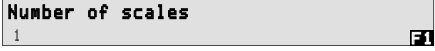



Figure 3-5. Ai-1 Indicator – Secondary Weigh Screen

Item No.	Description
1	Vehicles database entry key
2	Weighs List key – Press to print the current M+ weigh data
3	Menu key – Press to access the operations menu
4	Auto. Total key – Press for Weighs to auto print partial total prompt
5	Setpoint key – Press to view and edit the Outputs setpoint settings
6	Input Texts key – Press to view and edit the Input texts

Table 3-3. Ai-1 Indicator – Secondary Weigh Screen Descriptions

3.2.1 Pairing Ai-1 Indicator with Weigh Pads

1. Navigate to the **Technical Setup** menu ([Section 4.2 on page 34](#)).
2. Press  **Calibration** .
3. Press  **Scale selection** 
 1 scale/s
4. Press  **Number of scales** 
 1
5. Select the number of wheel weigh pads to be used.

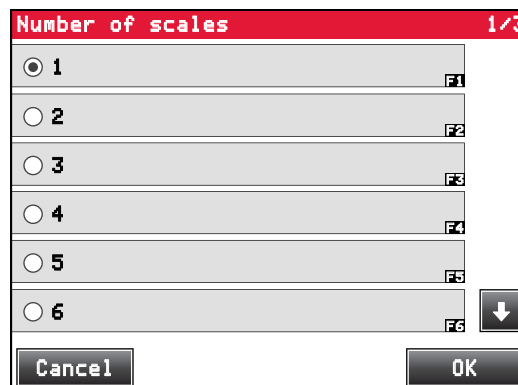

Figure 3-6. Select Number of Weigh Pads

6. Press .
7. Press .
8. Press .
9. Press to start pairing process. A prompt displays (Figure 3-7). Do not press anything at this time.

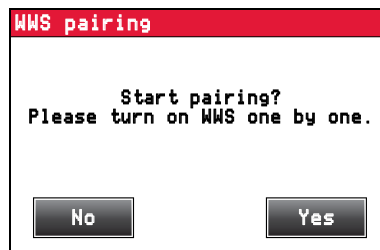

Figure 3-7. Start Pairing

10. Turn off all wheel weigh pads.
11. Turn on the first weigh pad only (pad assigned ID 01).
12. Press in the prompt window (Figure 3-7) to start the pairing process. **Connecting...** displays alongside the ID number.
13. Once the serial number of the first wheel weigh pad displays, turn on the second wheel weigh pad (assigned ID 02).

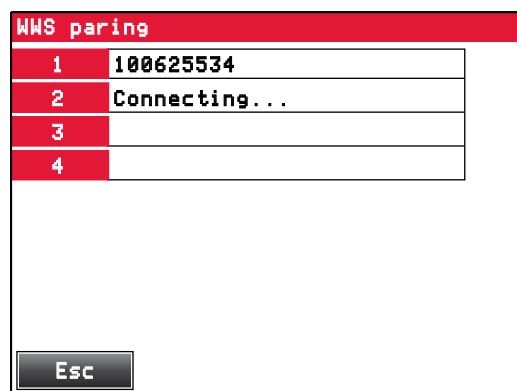

Figure 3-8. Pairing

14. Repeat this process until all of the weigh pad pin numbers in the desired system are displayed. Once the last wheel weigh pad is paired, a prompt displays.

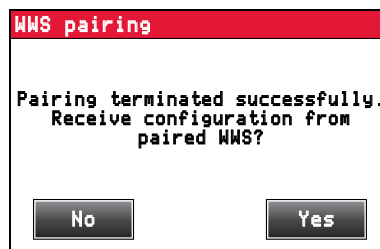

Figure 3-9. Pairing Successful

15. Press **Yes** to confirm the completion of pairing. The **Gravity Value Setting** keyboard displays.
- Press **No** to return to the **WWS Configuration** menu

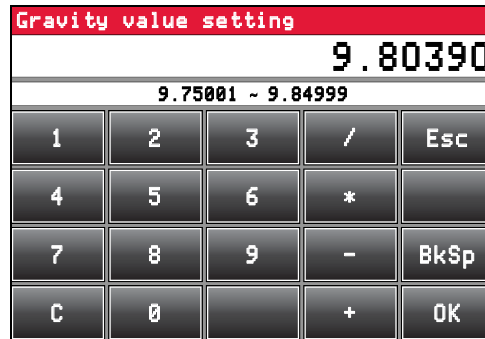

Figure 3-10. Set Gravity Value

16. Enter the gravity value for the area the wheel weigh pads are to be used in.
17. Press **OK**.
18. Press **←** three times to get back to the **Technical Setup** menu.

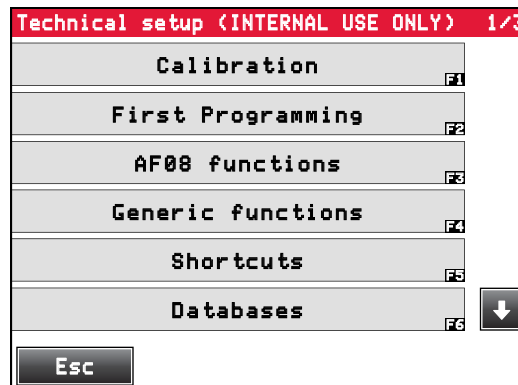

Figure 3-11. Technical Setup Menu

19. Press **Esc**. Setup changed box displays.



Figure 3-12. Setup Changed

20. Press **Yes** to save settings and complete setup. Indicator reboots to **Weigh** mode.

Initial Setup Parameters



The following parameter windows may display during initial setup before the indicator reboots to **Weigh** mode.



- The **Backup of the Configuration** window — Press **Yes** to backup all settings
- The **Password** window displays — Press **Yes** or **No**, depending if a password is needed or not
- The **Technical Setup** window displays — Press **Yes** to convert the indicator units to match the weigh pad units

3.3 Standard Ai-1 Indicator Functions

3.3.1 Zeroing Weigh Pads with Indicator

The Ai-1 indicator can zero all of the connected weigh pads at once or individually. The  annunciator displays if the wheel weigh pad weight is zeroed.

To zero the whole system (all of the connected weigh pads), ensure  S is displayed and press .

To zero an individual weigh pad, the corresponding scale number (Example:  1) must be displayed, then press .

 **NOTE:** The weight value displayed by the indicator also corresponds with scale annunciator ( S,  1,  2, etc.).

3.3.2 Tare Options

 **NOTE:** The tare weight is not subtracted from the displayed gross weight value, but from the sum total of the totalized axles.

The gross, tare and net weight are present when printing on multiple print formats (Section 3.8 on page 26).







Semiautomatic Tare

1. Load wheel weigh pad with the tare weight.
2. Press  to tare the gross weight on the wheel weigh pad. The weight value and the **PT** annunciator display.



Manual Tare

1. Touch the tare weight cell on the indicator display.
2. Type in the tare weight value and confirm by pressing . The entered value and the **PT** annunciator display.





Preset Vehicle Tare

1. Press  to switch the indicator display to the secondary weigh screen.
2. Press  to view the vehicle database.
3. Press a vehicle entry to edit. Example: 
4. Press the tare weight entry to edit. Example: 
5. Type in the tare weight value and confirm by pressing .
6. Press  to return to the vehicle database. Repeat previous steps if needed for additional tare weights.
7. Press  to return to the secondary weigh screen.

Tare Cancellation Options

- Press  with the weigh pads unloaded
- Manually set the tare weight value to zero
- Press 

Lock/Unlock Tare

1. Press  to switch the indicator display to the secondary weigh screen.
2. Press .
3. Press  Scale functions
4. Press  Lock/Unlock Tare. Display returns to the secondary weigh screen. Unlocked Tare or Locked Tare displays briefly in the indicator message cell.

3.4 Weighing Procedure

The Load Ranger Wheel Weigh Pads can be arranged in wheel-weighing systems with up to fourteen weigh pads and axle-weighing systems with only two weigh pads. This section highlights the differences between the two systems.

3.4.1 Wheel-Weighing System

A wheel-weighing system consists of as many platforms as there are vehicle wheels to be weighed. This method allows the user to weigh the whole vehicle in a single step. The Ai-1 indicator display simultaneously shows the weight of single wheels, axles and the total gross or net weight. The Ai-1 indicator also has the ability to show the center of gravity coordinates if setup correctly (Section 4.3 on page 36).

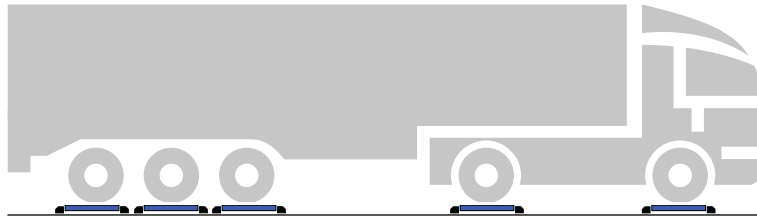

Figure 3-13. Wheel-Weighing System

Wheel-Weighing Procedure

1. Assign ID numbers to the wheel weigh pads (Section 3.1.3 on page 15) and pair Ai-1 indicator with the wheel weigh pads (Section 3.2.1 on page 17).
2. Position the wheel weigh pads (Section 2.2 on page 5).
3. Select the vehicle to be linked to the weigh if necessary (Section 3.7.4 on page 24).
4. Perform a full scale zero (Section 3.3.1 on page 20).
5. Position vehicle onto the platforms.
6. Press **M+**, once weight is stable.
 - If weight is captured correctly the indicator executes the printout for the weight of each wheel and axle, if configured.
 - If the scale is unable to capture the weight (*example*: due to instability) a prompt displays.
Press **Yes** to attempt weighing again or press **No** to cancel the weigh.
7. Press **TOTAL** to execute the printout of the total weight, minus the tare value if needed.
8. Remove the vehicle from the platforms.

3.4.2 Axle-Weighing System

An axle-weighing system consists of only two platforms. With this method, each axle of the vehicle is weighed separately and then added together. The Ai-1 indicator displays the weight of the current axle and the corresponding individual wheels, while also listing the previous axle weights and the total gross or net weight.



Figure 3-14. Axle-Weighing System



NOTE: To achieve the best weighing accuracy, release the parking brake and turn off the engine.
If the vehicle has self-leveling suspensions, disable them.

Axle-Weighing Procedure

1. Assign ID numbers to the wheel weigh pads (Section 3.1.3 on page 15) and pair Ai-1 indicator with the wheel weigh pads (Section 3.2.1 on page 17).
2. Position the wheel weigh pads (Section 2.2 on page 5).
3. Select the vehicle to be linked to the weight if necessary (Section 3.7.4 on page 24).
4. Perform a full scale zero (Section 3.3.1 on page 20).
5. Position the first part of the vehicle onto the platforms.
6. Once weight is stable, press **M+**.
 - If weight is captured correctly the indicator executes the printout of the weight of each wheel and axle, if configured.
 - If the scale is unable to capture the weight (*example*: due to instability) a prompt displays. Press **Yes** to attempt weighing again or press **No** to cancel the weigh.
7. Remove the current vehicle axle from the platforms.
8. Repeat previous steps until remaining axles have been weighed.
9. Press **TOTAL** to execute the printout of the total weight, minus the tare value if needed.



NOTE: The next press of **M+** resets the previous weight total and is considered the first axle of the next weight.

3.5 Battery Recharging

Wheel Weigh Pads

Use provided battery charging cable. The power connection port is located on the underside of the wheel weigh pad. For the RF-MD the port is located at the handle end of the platform and is the port closest to the edge. For the RF-WD and RF-XWD the port is located at the end opposite of the platform handles.



NOTE: The power connection port uses a 4-pin connector and the data communication port uses a 5-pin connector.

The battery charging cable light is a steady red when charging and turns to a steady green when fully charged.

Battery charging takes approximately four hours to reach a full charge.

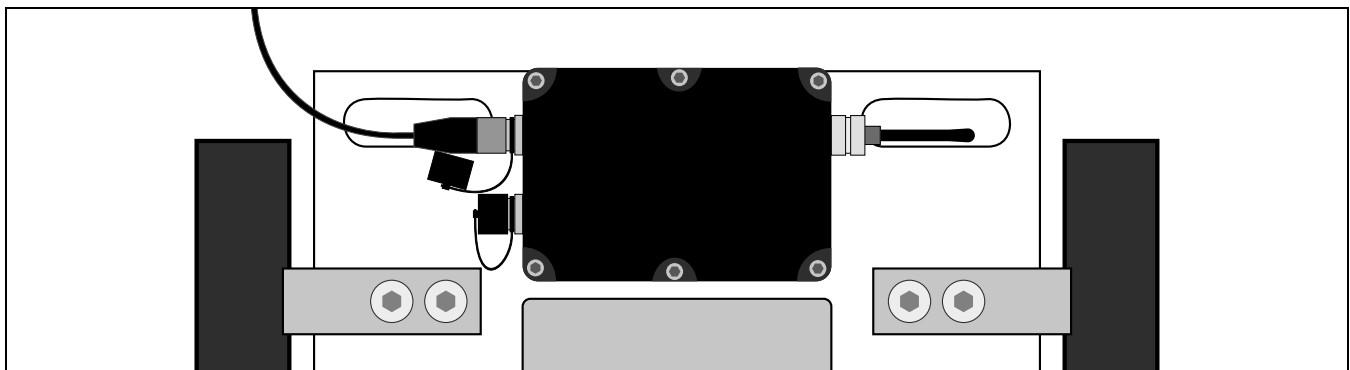

Figure 3-15. RF-MD Battery Cable Connection





Ai-1 Indicator

Use provided battery charging cable. The power light on the Ai-1 indicator is a steady red and the battery icon on the Ai-1 display changes to a plug icon when the battery charging cable is connected.

Battery charging takes approximately five hours to reach a full charge.

3.6 Input Texts

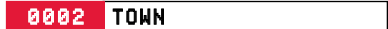
Associates manually entered content to the weight entry in the database.



1. Press  to switch the indicator display to the secondary weigh screen.
2. Press  to view the input text options.
3. Press the cell of the text to be changed.
Example: Press .
4. Use the displayed keyboard to enter the desired text.
5. Press  to confirm text.
6. Press  to return to the secondary weigh screen.

3.7 Vehicle Database



NOTE: The Description 1 text displays to the right of the vehicle database number. When vehicle entry is used, Description 1 and Description 2 is added to the printed ticket ([Section 3.8 on page 26](#)).

3.7.1 Create Vehicle

1. Press  to switch the indicator display to the secondary weigh screen.
2. Press  to view the vehicle database.
3. Press the cell next to the vehicle database number.

Example: Press .

Or press  at the bottom of the display to use the next available database number.

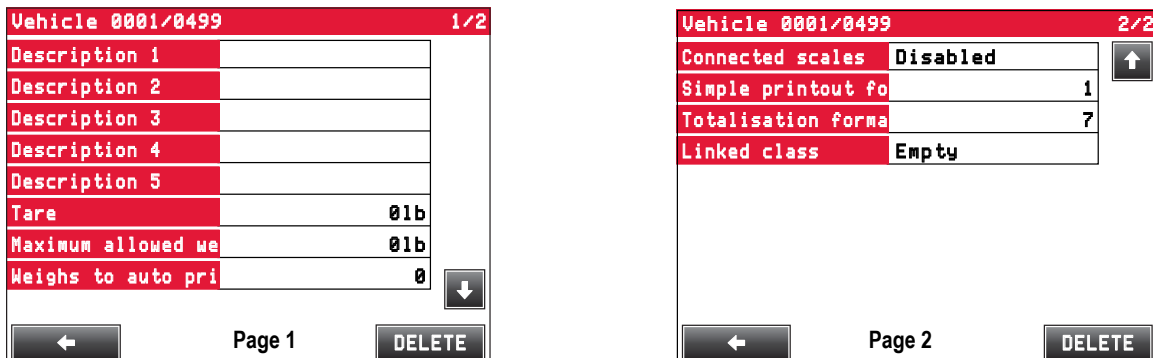





















Figure 3-16. Vehicle Database Entry

4. Press  to title the database entry.
5. Use the displayed keyboard to enter content.
6. Press  to confirm text.
7. Repeat procedure for all of the desired cells.
8. Press  to confirm database entry or press  to cancel.
9. Press  to return to the secondary weigh screen.

3.7.2 Modify Vehicle

1. Press  to switch the indicator display to the secondary weigh screen.
2. Press  to view the vehicle database.
3. Press the cell next to the vehicle database number to be modified.
Example: Press  .
- Or press  to search for the database entry to be modified ([Section 3.7.7 on page 25](#)).
4. Press the desired cell.
5. Use the displayed keyboard to enter content.
6. Press  to confirm content.
7. Repeat procedure for all cells that need to be modified.
8. Press  to confirm database entry update or press  to delete the entry.

3.7.3 Delete Vehicle

1. Press  to switch the indicator display to the secondary weigh screen.
2. Press  to view the vehicle database.
3. Press the cell next to the vehicle database number to be deleted.
 Or press  to search for the database entry to be deleted ([Section 3.7.7 on page 25](#)).
4. Press  to delete the database entry.
5. Press  to confirm or press  to cancel.



NOTE: If confirmed, Empty displays to the right of the vehicle database number.

6. Press  to return to the secondary weigh screen.

3.7.4 Select Vehicle on Primary Weigh Screen



1. Press the vehicle cell on the primary weigh screen to view the current list of vehicle database entries.
2. Press the desired vehicle entry to select. Vehicle description displays in vehicle cell.

3.7.5 Deselect Vehicle on Primary Weigh Screen

1. Press the vehicle cell on the primary weigh screen. The current list of vehicle database entries displays.



NOTE: The current selected vehicle database number is displayed at the bottom of the screen.

2. Press . A confirmation prompt displays.
3. Press  to confirm or press  to cancel. If confirmed, display returns to primary weigh screen and the vehicle cell is empty.

3.7.6 Temporary Vehicle

1. Press the vehicle cell on the primary weigh screen to view the current list of vehicle database entries.
2. Press **0000 Temporary**. The previous temporary entry will be cleared.

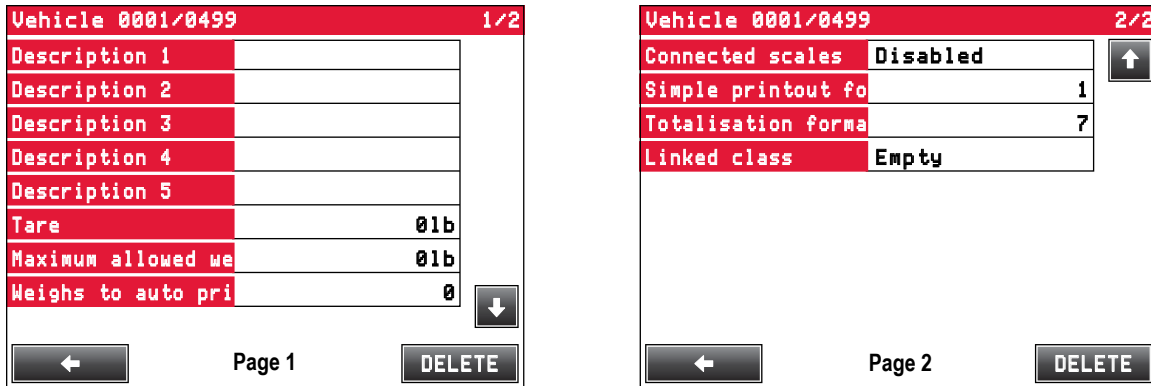

Figure 3-17. Vehicle Database Entry

3. Press the **Description 1** to title the temporary database entry.
4. Use the displayed keyboard to enter content.
5. Press **OK** to confirm text.
6. Repeat procedure for the desired cells.
7. Press **←** to confirm database entry and return to the primary weigh screen or press **DELETED** to cancel.



NOTE: The previous temporary entry has already been cleared and does not return if the new temporary entry is canceled.

3.7.7 Alphanumeric Search

1. Press the vehicle cell on the primary weigh screen to view current list of vehicle database entries to make a selection.
Or press **VEHICLES** on the secondary weigh screen to view the vehicle database for modifying entries.
2. Press **A..Z** in the vehicle database selection/modify screen.
3. Use the displayed keyboard to searched for a vehicle entry. Search results auto-filter as characters are entered.
4. Select vehicle from search results.

3.7.8 Index Search

1. Press the vehicle cell on the primary weigh screen to view current list of vehicle database entries to make a selection.
Or press **VEHICLES** on the secondary weigh screen to view the vehicle database for modifying entries.
2. Press **INDEX** in the vehicle database selection/modify screen.



NOTE: Within the database modify screen, press **>>** then press **INDEX**.

3. Use the displayed keypad to enter the vehicle database number.
4. Press **OK** to select the vehicle.





3.8 Print Formats

The Ai-1 indicator has 12 print functions and each function has an associated print format. When a function has been executed through the procedures in this section, the associated format is sent to the print serial port.

Item No.	Print Function	Description	Format
1	SIMPLE PRINTOUT	MENU -> Printout -> Simple printout With the approved instrument the net weight must be greater or equal to 20 divisions; With the non-approved instrument the net weight must be greater than zero	1
2	PARTIAL TOTAL	TOTAL in the main screen toolbar MENU -> Totals -> Print partial total	2
3	GENERAL TOTAL	MENU -> Totals -> Print general total	3
4	GRAND TOTAL	MENU -> Totals -> Print grand total	4
5	HANDLED VEHICLE TOTAL	MENU -> Totals -> Print vehicle total MENU -> Totals -> Print vehicles total	5
6	HEADING OF FIRST TOTALIZATION	M+ in the main screen toolbar	6
7	TOTALIZATION	M+ in the main screen toolbar	7
	LIST OF ALL THE WEIGHS	MENU -> Af08 functions -> Print weighs list Formats 8, 9, 10 are related to all weighs list	
8	LIST HEADING	Printed before the 1st list item	8
9	SINGLE WEIGH	Single item print format	9
10	SECTOR END	Printed after the total number of items	10
11	PRINT AT STARTUP	Printed at startup after the auto-zeroing procedure	11
12	RESULT OF THE CALCULATOR	MENU -> Generic functions -> Calculator	12

Table 3-4. Print Functions and Formats

There are 30 available print formats to associate to the print functions. To change the print format of the print function use the following procedure:

1. Press  to switch the indicator display to the secondary weigh screen.
2. Press .
3. Press .
4. Press . [Figure 3-18](#) displays.

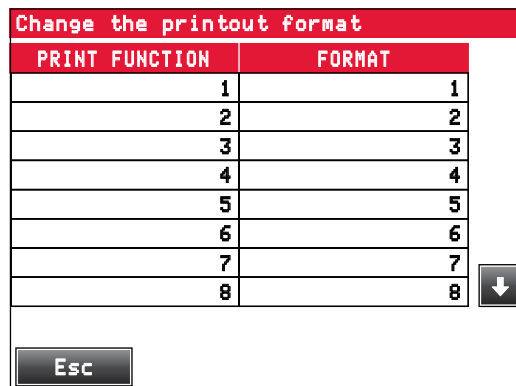

Change the printout format	
PRINT FUNCTION	FORMAT
1	1
2	2
3	3
4	4
5	5
6	6
7	7
8	8

Figure 3-18. Change Print Format Table

5. Press within the **FORMAT** column to change the print format associated with the corresponding print function.
6. Press  twice to save changes and return to the secondary weigh screen.

3.8.1 Default Print Formats

Printout Heading Section 4.2.4 on page 35	[Rice Lake Weighing Systems 800-472-6703
Vehicle Description 1 and 2 Section 3.7 on page 23	[RLWS TRUCK 1 WI RL4321
Date and Time Section 4.2.2 on page 35	—	25/06/18 09:37
Weight Breakdown	[WHEEL1 12001b WHEEL2 12501b AXLE 1 24501b WHEEL3 12701b WHEEL4 12801b AXLE 2 25501b
Weight Totals	[----- GROSS 50001b TARE 01b NET 50001b
Center of Gravity Section 4.3 on page 36	[GRAVITY CENTRE x= 0.00ft x= 0.00ft

Figure 3-19. Print Format 1

```

-----
GROSS          50001b
TARE           41501b
NET            8501b
    
```

Figure 3-20. Print Format 2

```

GENERAL TOTAL

WEIGHS          2
GROSS          85001b
TARE           55001b
NET            30001b
    
```

Figure 3-21. Print Format 3

```

GRAND TOTAL

WEIGHS          4
GROSS          185001b
TARE           110001b
NET            75001b
    
```

Figure 3-22. Print Format 4

```

Rice Lake
Weighing Systems
800-472-6703

VEHICLE TOTAL

RLWS TRUCK 2
WI RL8642

WEIGHS          2
GROSS          208001b
TARE           98001b
NET            110001b
    
```

Figure 3-23. Print Format 5

```

Rice Lake
Weighing Systems
800-472-6703

RLWS TRUCK 1
WI RL4321

25/06/18  09:41
    
```

Figure 3-24. Print Format 6

```

WHEEL 1      23001b
WHEEL 2      22501b
AXLE 1       45501b
    
```

Figure 3-25. Print Format 7

```

VEHICLE      0

RLWS TRUCK 2
WI RL8642

25/06/18  09:43
    
```

Figure 3-26. Print Format 8

```

WHEEL 1      23001b
WHEEL 2      22501b
AXLE 1       45501b
    
```

Figure 3-27. Print Format 9

```

-----
GROSS          50001b
TARE           10001b
NET            40001b
    
```

Figure 3-28. Print Format 10

```

-----
ERROR MESSAGE PRINTOUT
    
```

Figure 3-29. Print Format 11



```

      450 +
      550 =
-----
     1000
    
```

Figure 3-30. Print Format 12

3.9 Setpoints

Follow the procedure in this section to set the setpoint thresholds. See [Section 3.9.1](#) to change the setpoint functions.

1. Press  to switch the indicator display to the secondary weigh screen.
2. Press  to view the output setpoint settings.

Outputs setpoint setting		
Output	Value ON	Value OFF
1	01b	
2	01b	
3	01b	
4	01b	









Figure 3-31. Output Setpoint Settings

3. Press within the **Value ON** cell that needs to be changed.
4. Use the number pad to enter a new value and press .
5. Repeat for additional setpoints if needed.
6. Press  to save changes and return to the secondary weigh screen.



Note Press within the available **Output** cells to view the current setpoint function.

3.9.1 Change Setpoint Functions

1. Navigate to the **Technical Setup** menu ([Section 4.2 on page 34](#)).
2. Press .
3. Press .
4. Adjust outputs as needed.
5. Press . A prompt displays.
6. Press  to save changes. The indicator resets and returns to the weigh screen.

4.0 Configuration

This section provides the procedures necessary to access the **Technical Setup** menu of the Ai-1 indicator, to configure the settings in the **First Programming** menu and to configure center of gravity settings. It also outlines the procedures for accessing the wheel weigh pad **Technical Setup** menu and changing key parameters.

4.1 Weigh Pad Technical Menu

1. Press **⏻** to turn on the wheel weigh pad.
2. Press **⏴** during startup. **EEh** flashes, then **RL** displays.
3. Press **⏴** or **⏵** to scroll through the wheel weigh pad **Technical Setup** menu.

Parameter	Description
RL	Quick calibration; See Section 5.1 on page 38 to calibrate the wheel weigh pad
0.RL	Zero calibration; See Section 5.1.2 on page 39
GrAV	Gravity of use location; Enter value
SERIAL	Configuration of serial ports
id	Pad ID number configuration; Enter value: 00-99
bt. init	Resets the Bluetooth module and the connection to the associated host module
com.bt	Bluetooth communication port configuration; bAUD Settings: 1200, 2400, 4800, 9600, 19200, 38400, 57600, 115200
com.485	RS485 communication port configuration; bAUD Settings: 1200, 2400, 4800, 9600, 19200, 38400, 57600, 115200
Filter	Weighing filter – Must be set to Stand.3 for correct operation; Contact Rice Lake Weighing systems to use additional filters
Screen	Adjust display screen
backlit	Backlighting; Settings: no, YES (always on), Auto (on when weight is unstable)
brght	Brightness; Settings: brght 1- brght 5
Loch	Weight not displayed, press NUM to temporarily see the weight; Settings: no, YES
AutoOFF	Auto Off; Settings: no, YES
RESET	Factory configuration reset – Resets the device to the factory defaults, while maintaining the calibration in memory
diag	Diagnostics
ADC.uV	A/D converter – Check of input signal in μ V
disPLA	Display – Integrity check of all segments and icons
KEYb	Keyboard – Press any key to verify its correct operation, with beep and code on display
SER.num	Serial number of the scale
PRG.VER	Hardware revision (example: REU 5) followed by software version (Example: 04.06.01)
diu. int	Manufacturer use only
ADC.Pnt	Manufacturer use only
bt.RdC	Manufacturer use only
SERIAL	Manufacturer use only
bt.h	Bluetooth module test – Checks correct communication between the motherboard and the integrated Bluetooth module bt.oH – The Bluetooth module is communicating properly bt.Err – Communication is down between the two boards

Table 4-1. Weigh Pad Parameters and Descriptions

Parameter	Description
<i>AdvAnc</i>	Advanced
<i>CAL.PAR</i>	Calibration parameters: <i>dEC .n</i> – Decimal point; Settings: 0, 0.0, 0.00, 0.000 <i>d .U</i> – Division size; Settings: 1, 2, 5, 10, 50, 100, 200 <i>u.n</i> – Unit of measure; Settings: G, HG, t, Lb <i>rAnGE 1</i> – Wheel weigh pad capacity; Enter value: Max range = 800.000 <i>rAnGE 2-3</i> – For multi-range wheel weigh pads; Enter value
<i>CAL.AdJ</i>	See Section 5.1 on page 38 to calibrate the wheel weigh pad
<i>no .SE</i>	For correct system operation, this parameter must be set to <i>no</i>
<i>METRO</i>	Metrological parameters: <i>rEGUL</i> – Regulatory parameters menu : NTEP, OIML, Measurement Canada, Industrial Mode, NONE (Table 4-2 on page 32) <i>0.PERC</i> – Reset percentage via key; With approved scale: 0-2; With non-approved scale: 0-50 <i>d .Stb</i> – Sensitivity of the weight stability control; Settings: <i>no</i> 0- <i>no</i> 20 <i>0.tRH</i> – Zero hold function (tracking); Settings: <i>tr no</i> , <i>tr 1r4</i> , <i>tr 1r2</i> , <i>tr 1- 10</i> <i>on.ZERO</i> – Reset at power and reset percentage; Settings: <i>no</i> , <i>YES</i> (<i>0.PERC</i> – 10) <i>CAL.AdJ</i> – Manufacturer use only <i>CAL.PAR</i> – Manufacturer use only. Weight value for calibration converted for unit. <i>d.SALE</i> – Manufacturer use only
<i>LoCH.Hb</i>	Keyboard lock (Section 4.1.1)
<i>Pin.tEC</i>	Access PIN to Technical menu; Settings: <i>no</i> , <i>YES</i> (enter five digit pin number)
<i>Pin.uSE</i>	Access PIN to User menu; Settings: <i>no</i> , <i>YES</i> (enter five digit pin number)
<i>dFLt.t</i>	Total memory and calibration reset

Table 4-1. Weigh Pad Parameters and Descriptions (Continued)

4.1.1 Keyboard Lock

This prevents keys from accidentally being pressed during weighing.









1. Navigate to the weigh pad Technical menu ([Section 4.1 on page 30](#)). *CAL* displays.
2. Press . *AdvAnc* displays.
3. Press . *CAL.PAR* displays.
4. Press to scroll through parameter options until *LoCH.Hb* displays.
5. Press . The current keyboard lock setting displays.
6. Press to scroll through settings and press to save selection.
7. Press four times to back out of the menu. *SAUEP* displays.
8. Press . *StorE* briefly displays and unit returns to **Weigh** mode.

4.1.2 Default Weigh Pad

Total reset of memory and calibration to the manufacturer settings.

1. Navigate to the weigh pad Technical menu ([Section 4.1 on page 30](#)). *CAL* displays.
2. Press . *AdvAnc* displays.
3. Press . *CAL.PAR* displays.
4. Press . *dFLt.t* displays.
5. Press . *SAUEP* displays.
6. Press to default the weigh pad. *UR .t* displays while process runs, then *CAL.PAR* displays.
7. Press two times to back out of the menu. *SAUEP* displays.
8. Press . *StorE* briefly displays, then *CAL* displays. See [Section 5.1 on page 38](#) to recalibrate the weigh pad.

4.1.3 Weigh Pad Metrological Configuration

1. Navigate to the weigh pad Technical menu (Section 4.1 on page 30). *CAL* displays.
2. Press . *ADUARC* displays.
3. Press . *CAL.PAR* displays.
4. Press  or  until *NETOL* displays.
5. Press . *RECAL* displays.
6. Press  the current metrological parameter displays.
7. Press  or  until the desired metrological parameter displays then press .

Regulatory Parameter	Weight on Scale	Tare in System	Front Panel Key Function	
			Tare	Zero
NTEP	Zero or negative	No	No action	Zero
		Yes	Clear tare	
	Positive	No	Tare	
		Yes	Tare	
OIML	Zero or negative	No	No action	Zero
		Yes	Clear tare	Zero and Clear Tare
	Positive	No	Tare	Zero
		Yes	Tare	Zero and Clear Tare if weight is within ZRANGE; No action if weight is outside of ZRANGE
Measurement Canada	Zero or negative	No	No action	Zero
		Yes	Clear tare	
	Positive	No	Tare	
		Yes	No Action	
Industrial Mode	Allows users to configure industrial settings			
NONE	Zero or negative	No	Tare	Zero
		Yes	Clear tare	
	Positive	No	Tare	
		Yes	Clear tare	

Table 4-2. Metrological Functions



NOTE: OIML

*Zero function clears the existing tare.

NTEP and Measurement Canada

*Indication at zero in NTEP and Measurement Canada with the same number of 0 as character for d. If d=50g the indication at zero should indicate 00 g.

*The Zero function performs the zero only.

*Max value for automatic zeroing = 20%.

*In legal for trade mode, the weight is never shown when master is connected.



Measurement Canada

*Multiple tares are not allowed, tare must be cleared prior to entering a new tare.

*When zeroing, the scale reduces maximum indication of the same amount. Max value = 100%.

* Center of Zero (CoZ) cannot be displayed if showing a negative net weight.

4.1.4 View Weigh Pad Metrological

1. Press  to turn on the wheel weigh pad.
2. Press  during startup.
3. Metrological version briefly display (HH, HH) then weighing program version briefly displays (HH, HH, HH).

4.1.5 Overload Range

1. Navigate to the weigh pad Technical menu (Section 4.1 on page 30). \overline{CAL} displays.
2. Press \uparrow . ADU displays.
3. Press \leftarrow . $\overline{CAL.PAR}$ displays.
4. Press \uparrow or \downarrow until $NEED$ displays.
5. Press \leftarrow . $REWL$ displays.
6. Press \uparrow or \downarrow until $OVER$ displays.
7. The current overload condition displays. Press \uparrow or \downarrow until the desired overload condition displays then press \leftarrow .

Condition	Description
FS + 9 DIVISIONS	OIML Default
FS + 2%	NTEP/Measurement Canada Default
FS + 1 DIVISIONS	-
FS	-
NOTE: The system default settings are: Metrological Function: NTEP / Measurement Canada Overload Range: FS + 2%	

Table 4-3. Overload Range Settings

 **NOTE:** See Table 4-2 on page 32 for additional metrological information.

4.1.6 Unit Conversion

By default the Load Ranger is configured to operate with pounds (lb) as the unit of measure. This section discusses how to change units of measure, capacity, and set the calibration weight.

 **NOTE:** Units available are pound (lb), kilogram (kg), gram (g) and Short Ton (tn).

Set units and Capacity

To change the units of measure and set the capacity, perform the following:

1. Navigate to the weigh pad Technical menu (Section 4.1 on page 30). \overline{CAL} displays.
2. Press \uparrow . ADU displays.
3. Press \leftarrow . $\overline{CAL.PAR}$ displays.
4. Press \leftarrow . DEC displays.
5. Press \uparrow or \downarrow until $UNIT$ displays.
6. Press \leftarrow . Currently selected unit displays.
7. Press \uparrow or \downarrow until desired unit displays.
8. Press \leftarrow . $RANGE$ displays.
9. Press \leftarrow . Current range displays.
10. Press \uparrow , \downarrow , \leftarrow and \rightarrow until desired range displays.

 **NOTE:** The Range parameter value is a conversion value from pounds to the desired units. For example, 1 lb is 0.45359237 kg. Table 4-4 shows unit conversion values for 1 lb.

Ib Conversion Weight	Conversion Unit	Conversion Value
1	g	453.59237
1	kg	0.45359237
1	Short ton	0.0005

Table 4-4. Overload Range Settings

11. Press . Conversion value is accepted and *rRnSE 2* displays.
12. Repeat steps 9 through 11 for remaining ranges.
13. *dEc n* displays.
14. Press three times to exit the Technical menu.

Weight for Calibration

To set the weight for calibration, perform the following:

1. Navigate to the weigh pad Technical menu ([Section 4.1 on page 30](#)). *LR* displays.
2. Press . *AduRnL* displays.
3. Press . *LR.PPr* displays.
4. Press or until *NETROL* displays.
5. Press . *REQU* displays.
6. Press or until *LR.PPr* displays.
7. Press or until *Point* displays.
8. Press . *WEght* displays.
9. Press , , and until desired weight is set.



NOTE: The Weight parameter value is a conversion value from pounds to the desired units. For example, 1 lb is 0.45359237 kg. [Table 4-4](#) shows unit conversion values for 1 lb.

lb Conversion Weight	Conversion Unit	Conversion Value
1	g	453.59237
1	kg	0.45359237
1	Short ton	0.0005

Table 4-5. Overload Range Settings

10. Press . *Point5* displays.
11. repeat steps 8 through 10. *REQU* displays.
12. Press three times to exit the Technical menu.

4.2 Indicator Technical Setup Menu

1. Press to turn on the Ai-1 indicator.
2. During startup, press the upper right corner of the screen when the logo displays to enter the **Technical Setup** menu.



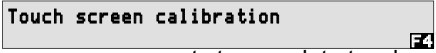

Figure 4-1. Touch Upper Right Corner of the Display

4.2.1 Configure Touch Display

1. Navigate to the **Technical Setup** menu ([Section 4.2](#)).
2. Press .
3. Press .
4. Follow on-screen prompts to complete touch screen calibration.



4.2.2 Date and Time

1. Navigate to the **Technical Setup** menu ([Section 4.2](#)).
2. Press .
3. Press .
4. Set the date and time. Date is set DD / MM / YY. Time is set in military standard time.



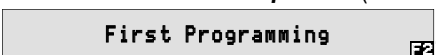

NOTE: Date and time can also be set in weighing mode by pressing within the time cell in the upper left corner of the screen.

4.2.3 Date and Time Password

1. Navigate to the **Technical Setup** menu ([Section 4.2 on page 34](#)).
2. Press .
3. Press .
4. Press .

4.2.4 Printout Headings

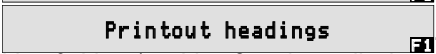
1. Navigate to the **Technical Setup** menu ([Section 4.2 on page 34](#)).
2. Press .
3. Press .
4. Press .
5. Press Line 0, Line 1 or Line 2 and use displayed keyboard to enter content.



NOTE: The printout headings display at the top of all printouts.

4.2.5 Shortcuts

Toolbar Customization

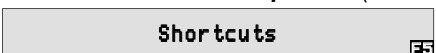
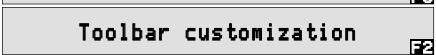
1. Navigate to the **Technical Setup** menu ([Section 4.2 on page 34](#)).
2. Press .
3. Press .
4. Select a button to customize the title and the function.



NOTE: Changing the function buttons of the display toolbar impacts weighing procedures described in this manual.

4.3 Center of Gravity

The instrument is able to calculate and print the center of gravity coordinates of the vehicle being weighed.

NOTE: *The weight of each weigh pad must be greater than zero to calculate center of gravity.*
The Gravity Center cell only appears on the Ai-1 indicator display when three or more weigh pads are connected.

Follow this procedure to calculate the center of gravity of a vehicle with four wheels.

1. Position vehicle on the wheel weigh pads.
2. Press the gravity center cell on the primary weigh screen of the Ai-1 indicator.
3. Input the vehicle measurements. Refer to [Figure 4-2](#) for how to specify the coordinates.
 Example: vehicle with four wheels, that has a width of 13' and a length of 15'.

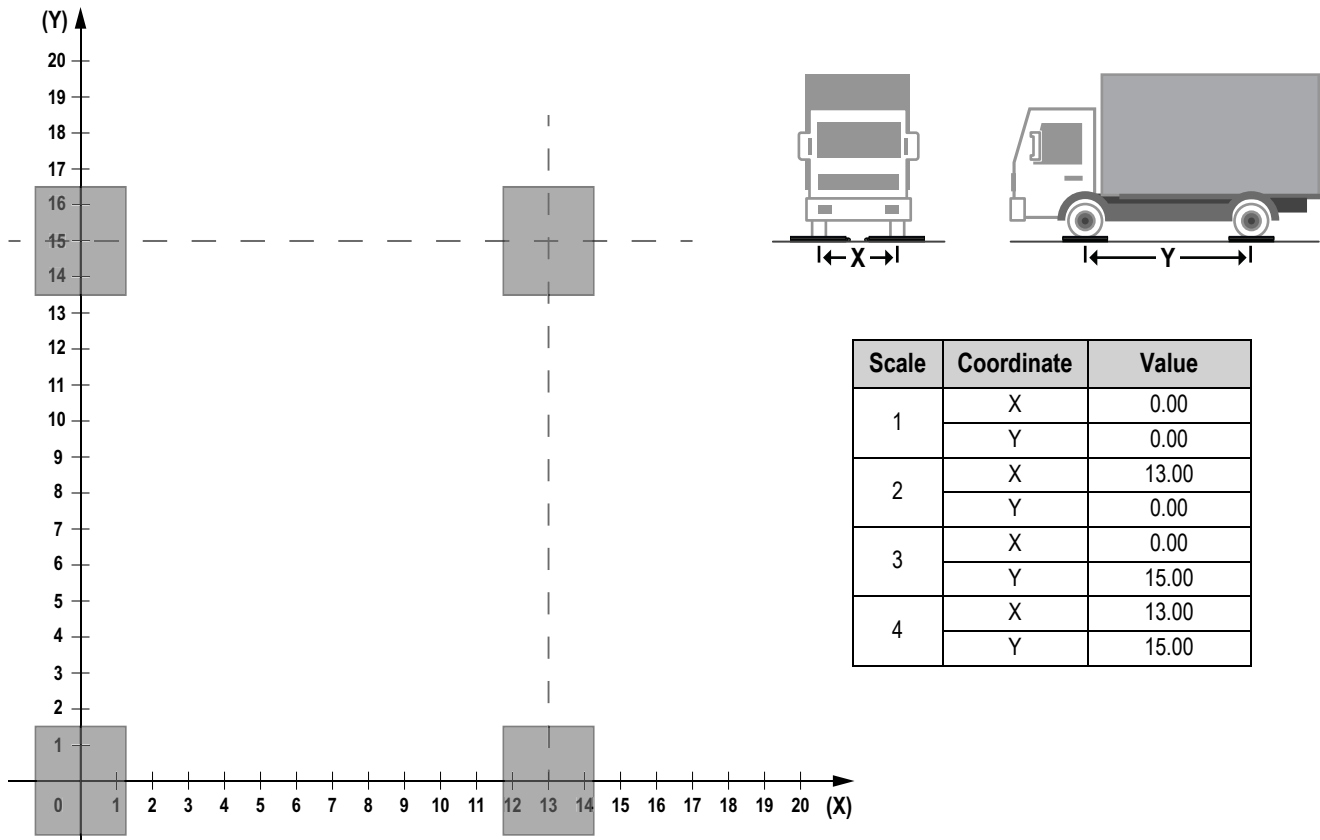



Figure 4-2. Center of Gravity Graph

4.3.1 Center of Gravity Units

Follow this procedure to change the units indicated with the Center of Gravity calculation.

1. Navigate to the **Technical Setup** menu ([Section 4.2 on page 34](#)).
2. Press **AF08 functions**.
3. Press **Gravity Center Calculation**.
4. Press **Coordinates unit of measure**.
5. Use displayed keyboard to enter units abbreviation and press **OK**.
6. Press **Esc**, then press **Yes** to save changes. Indicator restarts and returns to the weigh screen.



4.3.2 Indicator Metrological Configuration

1. Navigate to the **Technical Setup** menu ([Section 4.2 on page 34](#)).
2. Press .
3. Press .
4. Select the desired metrological parameter:
 - OIML
 - **NTEP** (Default)
 - CANADA



NOTE: See [Table 4-2 on page 32](#) for additional metrological information.

4.3.3 Overload Range

1. Navigate to the **Technical Setup** menu ([Section 4.2 on page 34](#)).
2. Press .
3. Press .
4. Press .
5. Select the desired overload condition ([Table 4-3 on page 33](#)).

5.0 Calibration

This section provides the procedures necessary to calibrate the Load Ranger wheel weigh pads through the built-in displays and with the Ai-1 indicator.

 **NOTE:** When using the Ai-1 indicator with the weigh pads, skip to [Section 5.2 on page 39](#) to calibrate all of the weigh pads through the Ai-1 indicator.

5.1 Calibrate with Wheel Weigh Pad Display

This section describes procedures for setting calibration parameters and the calibration of the Load Ranger Wheel Weigh Pads through the built-in display.











5.1.1 Complete Calibration Procedure

Follow these steps to set the calibration parameters and complete a calibration:

 **NOTE:** Press  at any time to back out one level or multiple times to return to the Weigh mode.

1. Turn indicator on by pressing  and press  during startup. `CAL` displays.
2. Press . `CAL.PAR` displays.









 **NOTE:** If `dIU` displays instead of `CAL.PAR`, press , then press  two times until `ADJRN` displays. Press  and `CAL.PAR` displays then continue with [Step 3](#).

3. Press . `dEE iN` displays.
4. Press . The current decimal setting displays.
5. Press  to scroll through decimal settings and press  to save selection. `dIU` displays.
6. Press . The current division setting displays.
7. Press  to scroll through division settings and press  to save selection. `u.N.` displays.
8. Press . The current unit setting displays.
9. Press  to scroll through unit settings and press  to save selection. `rRnEE 1` displays.
10. Press . Range 1 value displays. Use the numeric entry procedure to set value.

 **NOTE:** For single-range wheel weigh pads, Range 1 is set as the max wheel weigh pad capacity.

11. Press . `rRnEE2` displays.

 **NOTE:** Range 2 should only be set for multi-range wheel weigh pads. For single-range wheel weigh pads, skip to [Step 14](#).

12. Press . Range 2 value displays. Use the numeric entry procedure to set value.
13. Press . `dEE iN` displays.
14. Press . `CAL.ADU` displays.
15. Press . `ZERO` displays. Ensure weigh pad is unloaded.
16. Press . `-OH-` briefly displays once the procedure is complete, then `CAL.Pnt` displays.
17. Press . The current setting for the number of calibration points displays.
18. Press  to scroll through settings (1-3) and press  to save selection. Calibration point 1 value displays.
19. Use the numeric entry procedure to set the calibration weight value and press . `LOAD` displays.

20. Load the weight specified for calibration point 1.



NOTE: For proper calibration, use a calibration weight of at least half of the capacity when loading the calibration weight for calibration.

- If doing multiple calibration points, **-oH-** briefly displays once the calibration procedure is complete for calibration point 1, then the calibration point 2 value displays.
- If doing a single calibration point, **uNL.oPd** displays. Skip to [Step 23](#).

21. Repeat [Step 19 on page 38](#)–[Step 20](#) for calibration point 2 and 3 if needed.

22. Once the calibration procedure is complete for the final calibration point, **uNL.oPd** displays.

23. Unload the weigh pad. **LRL.oH** briefly displays, then **cRL.Pnt** displays.

24. Press **⏪** four times to back out of the menu. **SRUEP** displays.

25. Press **↩**. **StorE** briefly displays and unit returns to **Weigh** mode.

5.1.2 Zero Calibration Procedure

Follow these steps to complete a zero calibration through the weigh pad display:

1. Turn indicator on by pressing **⏪** and press **⏴** during startup. **LRL** displays.
2. Press **⏴**. **o.CAL** displays.
3. Press **↩**. **SurEP** displays.
4. Press **↩**. **LRL.oH** briefly displays once calibration procedure is complete, then **LRU** displays.
5. Press **⏪**. **SRUEP** displays.
6. Press **↩**. **StorE** briefly displays and unit returns to **Weigh** mode.

Or press **⏪** to cancel and unit returns to **Weigh** mode.

5.2 Calibrate with Ai-1 Indicator

5.2.1 Standard Calibration

1. Navigate to the **Technical Setup** menu ([Section 4.2 on page 34](#)).

2. Press **Calibration**.

3. Press **Scale X**.



NOTE: To change calibration parameters (decimals, units, divisions, etc.), press **Parameters**.
By changing parameters in one wheel weigh pad, the Ai-1 indicator sets all other paired wheel weigh pads to the same parameters selected.

4. Press **Calibration**. Calibration points message displays.

5. Press **OK**. Calibration zero acquisition prompt displays.



6. Unload the wheel weigh pad and press **OK**. Calibration acquisition of point 1 message displays.

7. Press **OK**. Calibration point 1 weight prompt displays.

8. Enter the weight value of the calibration point and press **OK**. Calibration load weight prompt displays.

9. Load the wheel weigh pad with a test weight equal to the entered value and press **OK**. Once procedure is complete, a successful calibration message displays.









10. Press **OK**.

11. Press  to return to the **Calibration** menu.
12. Repeat [Step 3 on page 39–Step 11](#) until all wheel weigh pads have been calibrated.
13. Press , then press  to save changes. Indicator restarts and returns to the weigh screen.



NOTE: When the Ai-1 indicator is off the weigh pads do not retain the calibration settings configured through the Ai-1 indicator. The weigh pads return to their own previously configured settings or defaults. Once the Ai-1 indicator is turned back on the indicator settings are restored from the previous use.

5.2.2 Zero Calibration

1. Navigate to the **Technical Setup** menu ([Section 4.2 on page 34](#)).
2. Press .
3. Press .
4. Press . A prompt displays to unload the platform.
5. Unload the weigh pad and press . A prompt displays to confirm the zero calibration was successful once procedure is complete.
6. Press .
7. Press  to return to the **Calibration** menu.
8. Repeat [Step 3–Step 7](#) to complete a zero calibration for the remaining wheel weigh pads.
9. Press , then press  to save changes. Indicator restarts and returns to the weigh screen.

6.0 Maintenance

Periodically check the operation of the wheel weigh pads to ensure accuracy over time.

The pads must be checked by a specialist with test weights to obtain an official calibration certificate.

6.1 Operation Check

The following procedure can also be used for an uncertified check of the operation of the wheel weigh pads:

Place one or two pads on the edge of a truck scale and proceed with the weighing of individual wheel or the first axle. Ensure the weights displayed by the two systems are equal.

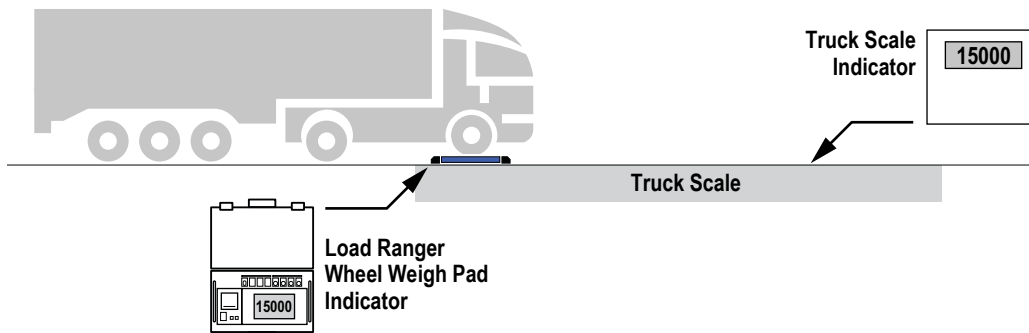

Single Platform Test

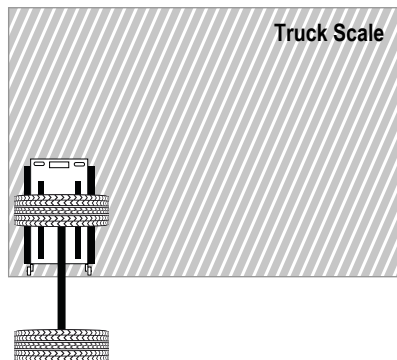

Axle-Weighing Test

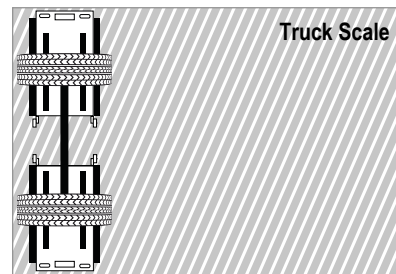

6.2 Maintenance and Cleaning

- Remove any debris from the weighing area, as well as the area under the wheel weigh pads, that may prevent the loading surface from bending correctly
- Clean the platform with non-aggressive substances
- Periodically check the condition of the connection cables
- Fully charge the battery before prolonged non-use

6.3 Accessory Assembly

6.3.1 Display Cover

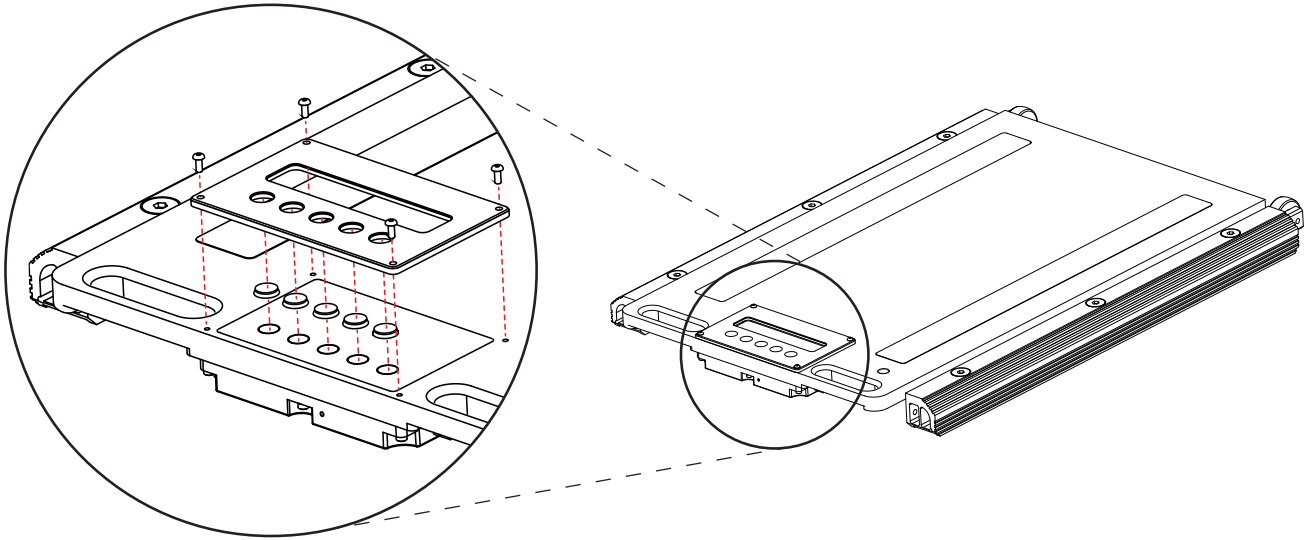

6.3.2 Transport Wheels

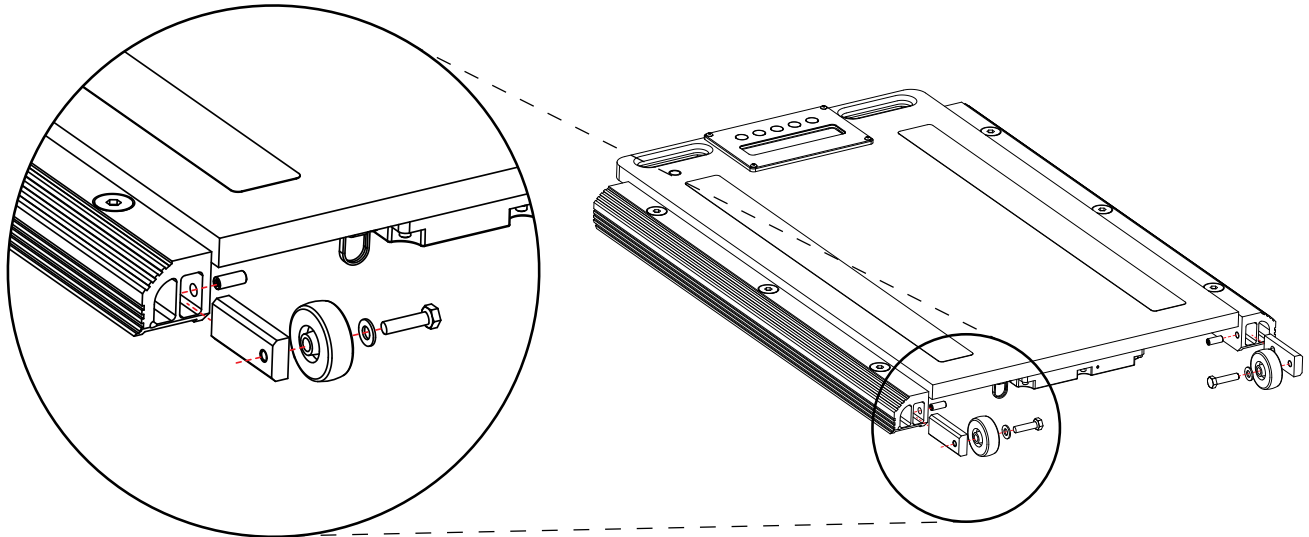

6.3.3 Aluminum Ramps



NOTE: The wheels may need to be loosened to insert the threaded pins. Use a rubber mallet if needed, but ensure the threads are facing outwards. The pin is slightly wider on the threaded side.

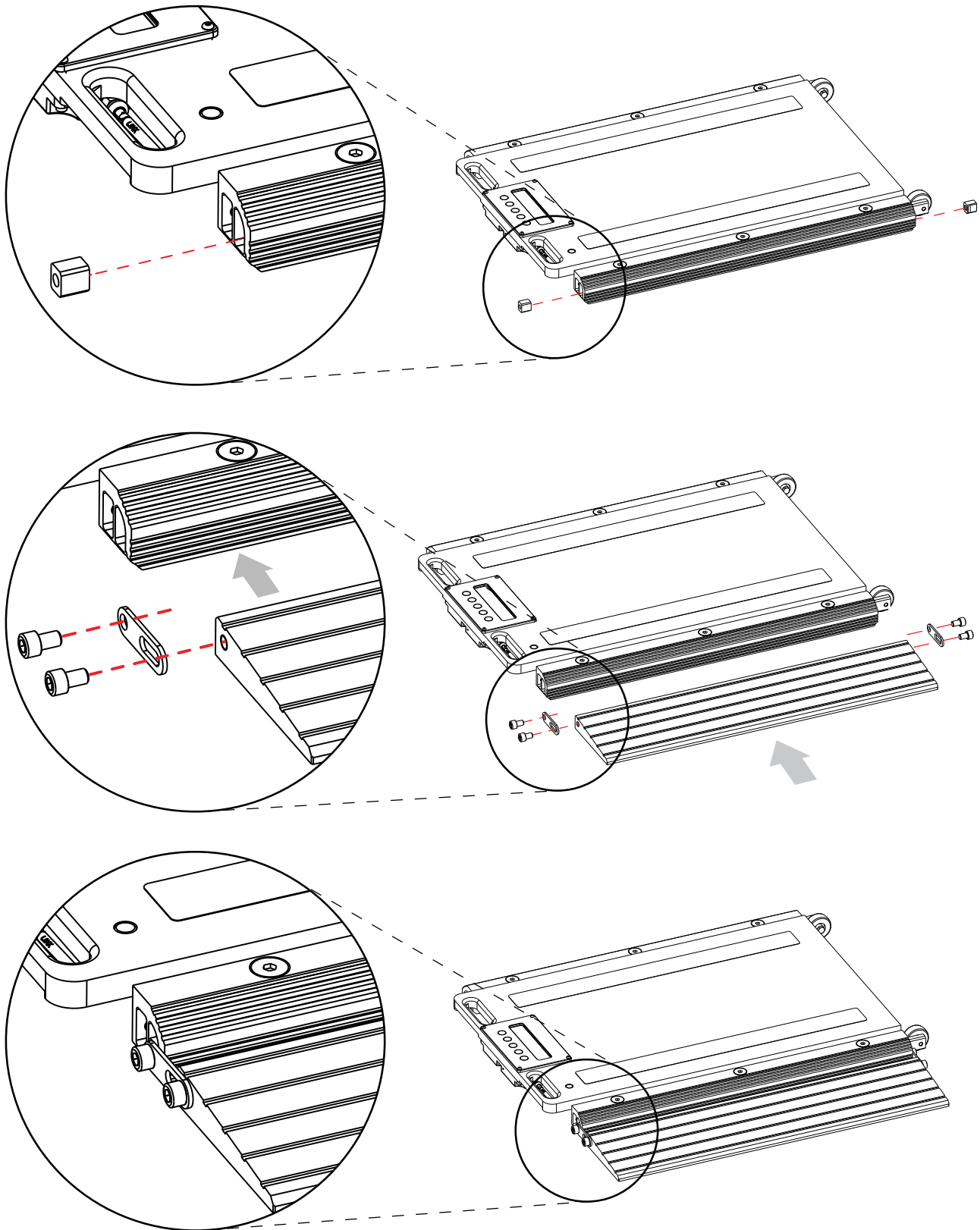

6.4 Board Diagram

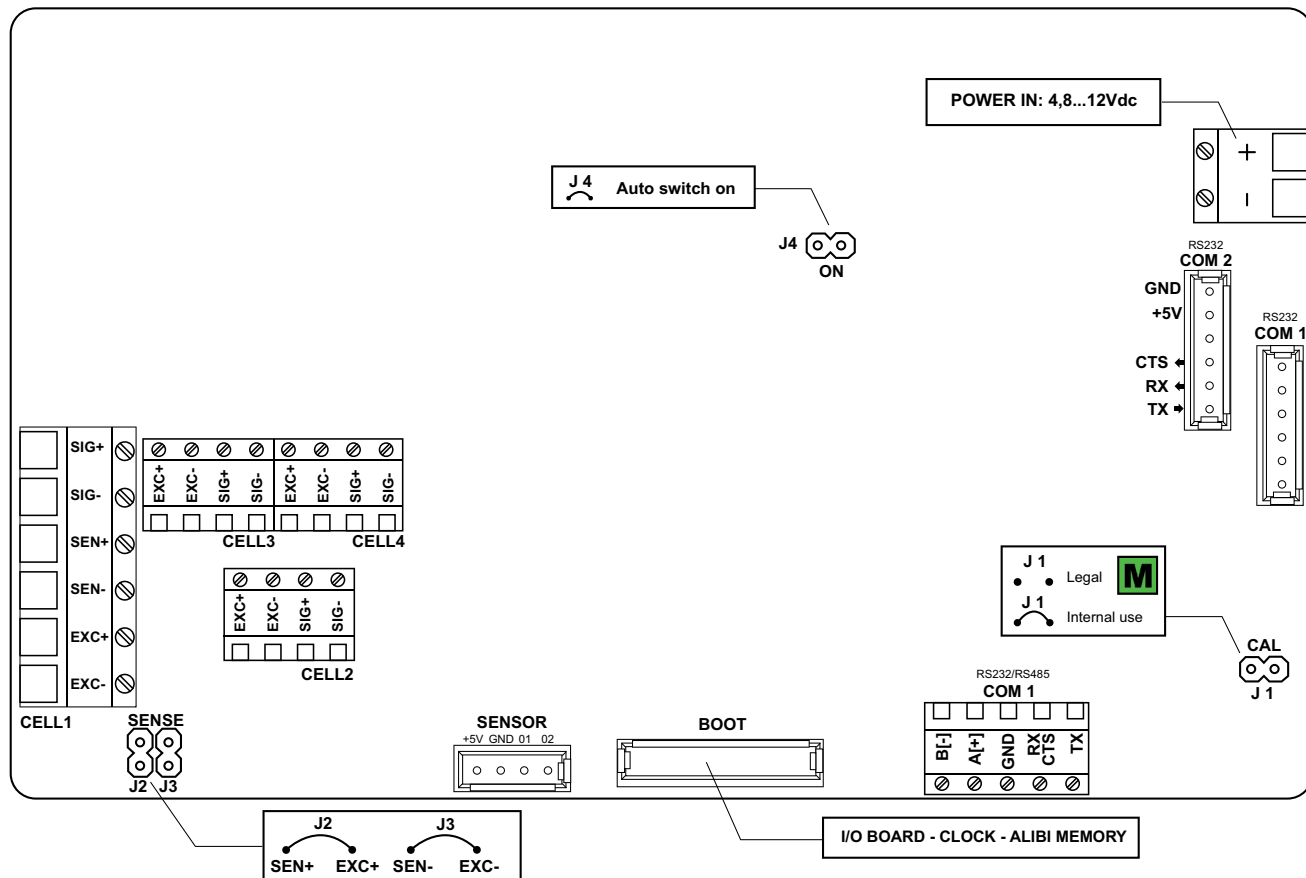
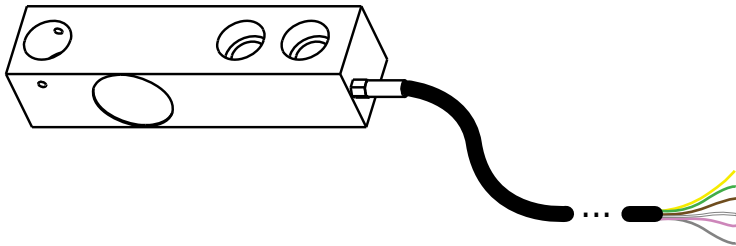

Figure 6-1. Wheel Weigh Pad Board Diagram

6.5 Wiring Schemes

6.5.1 Load Cell Wiring

Load Cell Cable



Interconnection Cable

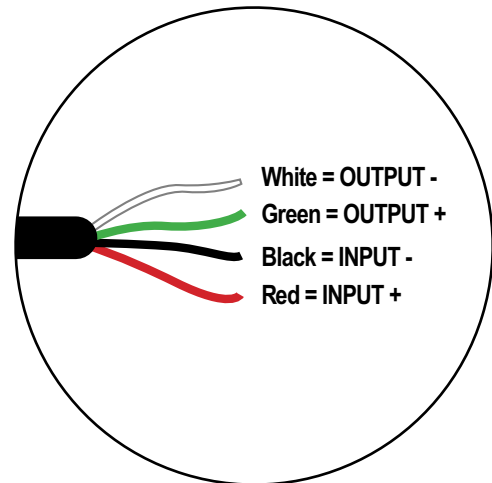
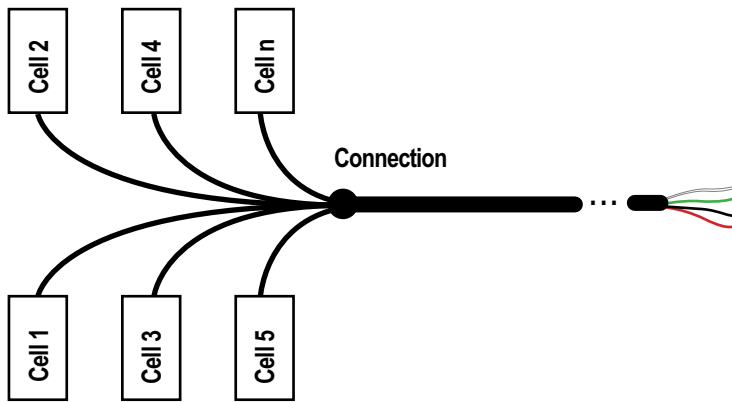

Board Connection

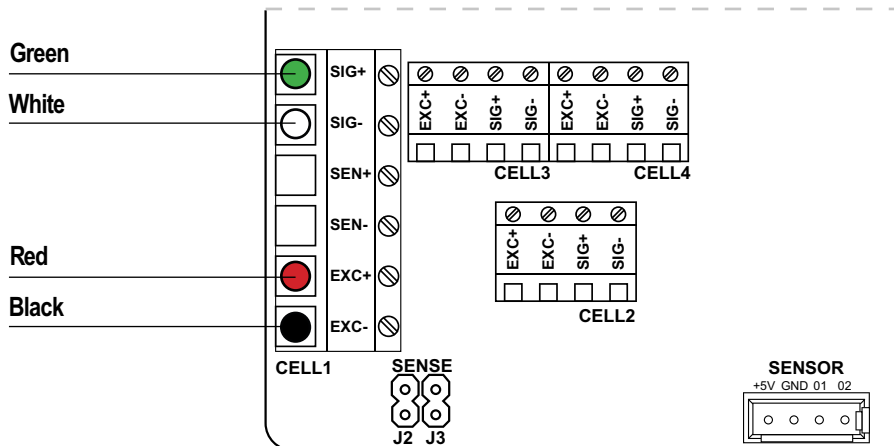

Location On Board

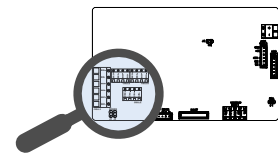

6.5.2 Power Supply Wiring

Charging Connector Position

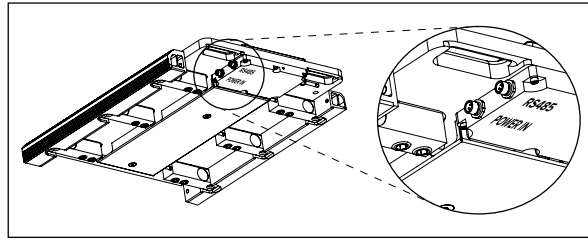
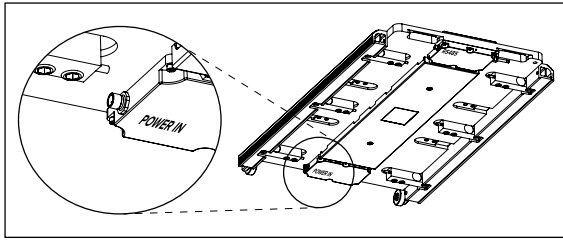

Pin Configuration

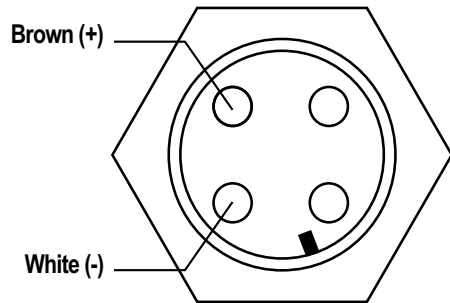

Board Connection

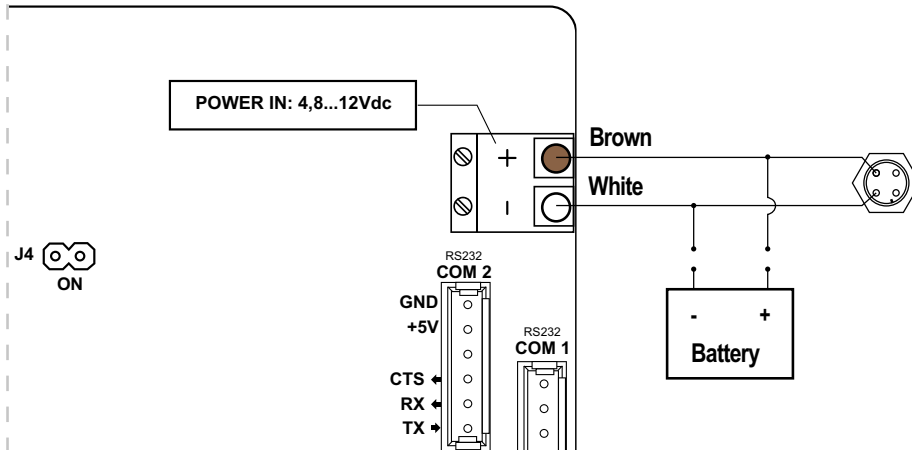

Location On Board

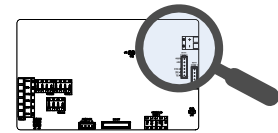

6.5.3 RS485 Wiring

RS485 Connector Position

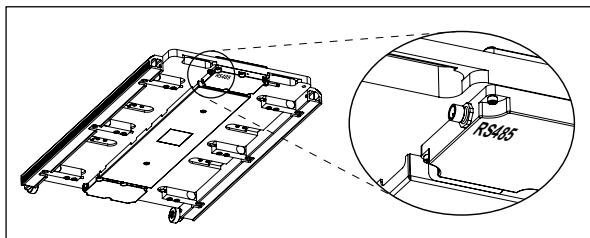

Pin Configuration

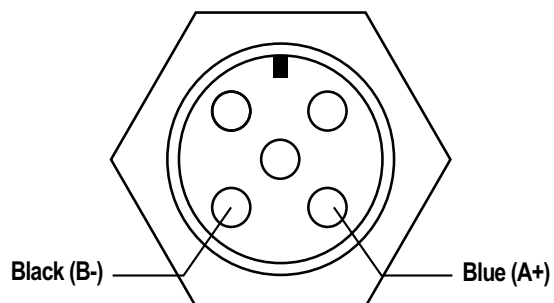

Board Connection

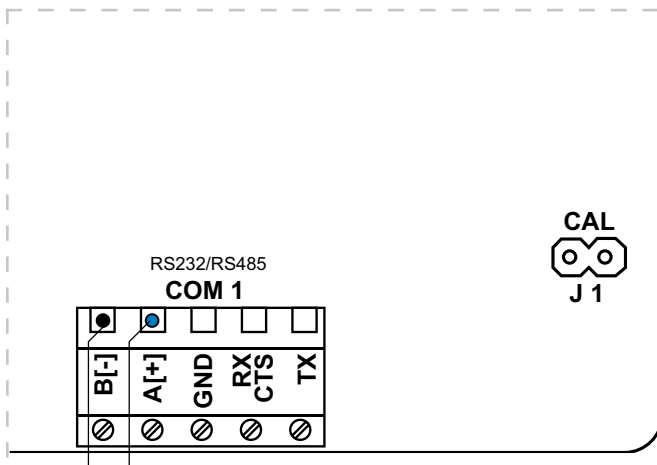

Location On Board

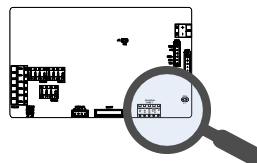

6.5.4 Bluetooth Connection

The Bluetooth module is built into the platform. The antenna is in an optimal position for continuous communication.

! **IMPORTANT:** The antenna is protected against impact and crushing. Do not modify the angle or the position of the antenna. Only use the provided antenna or a Rice Lake Weighing Systems replacement.

Bluetooth Antenna Position

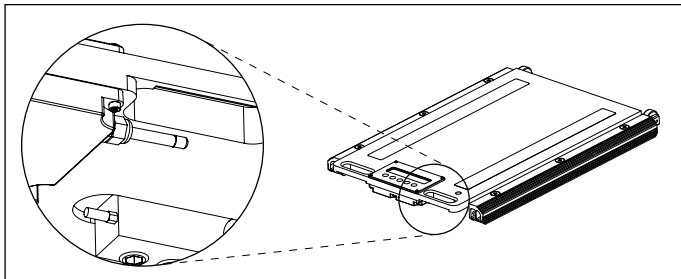

Board Connection

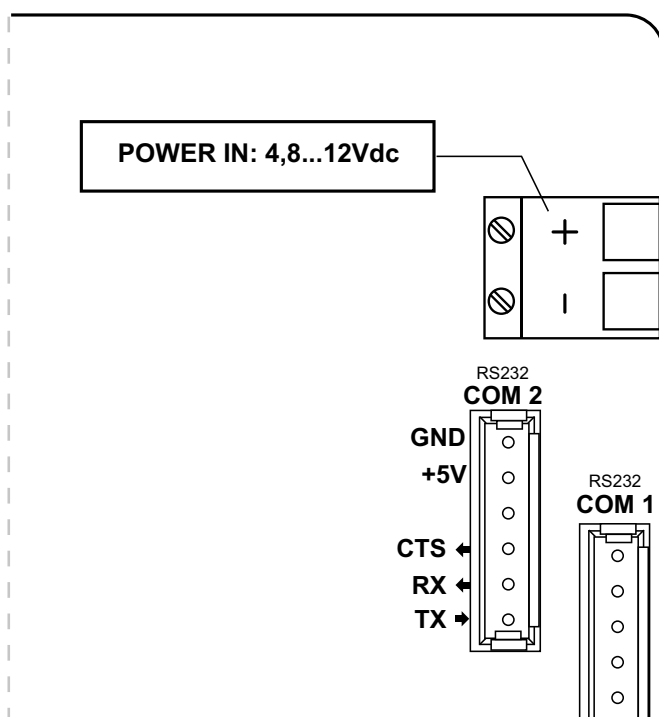

Location On Board

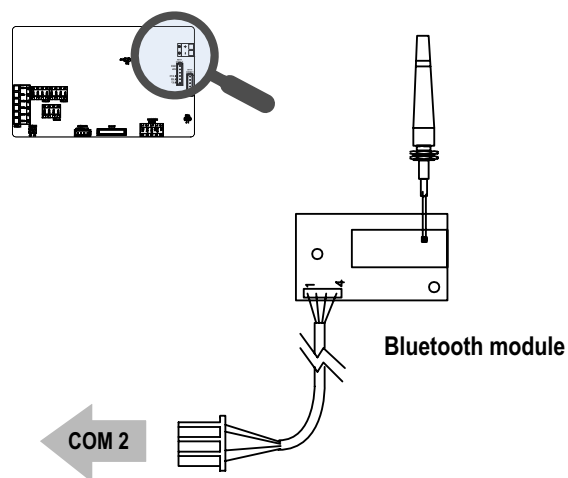

6.6 Calibration Jumper

Calibration access can be restricted by removing the calibration jumper.

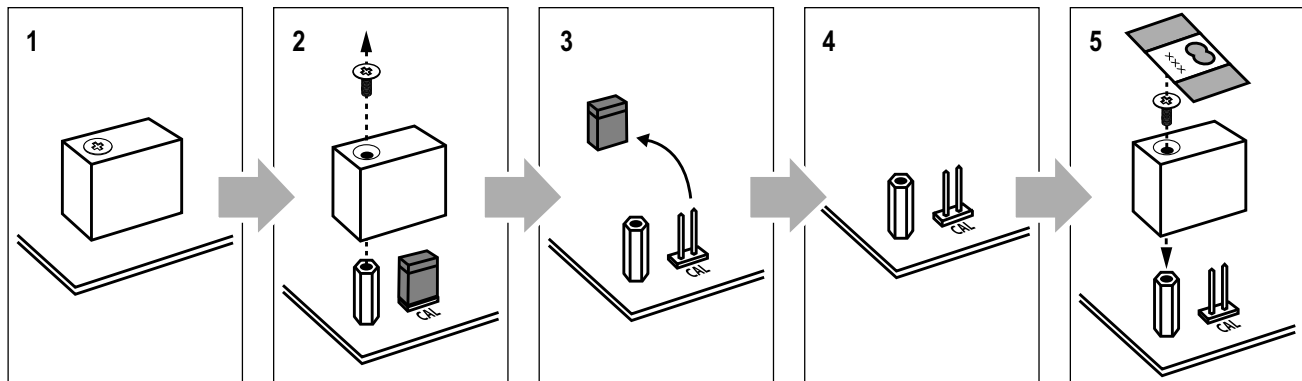

6.7 Messages and Errors

Message	Description
<i>PL 1 PL 2 PL 3 PL 4 ...</i>	If the WWP radios are type-approved, the display shows the platform number instead of the weight
<i>ZEro</i>	Weight reset in progress; contact technical support if the message persists
<i>Er. Plat</i>	Unstable weight when acquiring a point during the calibration phase
<i>undEr</i> (flashing)	Weighing error; unload the platform, turn it off and turn on the indicator again; contact technical support if the problem persists
<i>oUEr</i> (flashing)	If the weight exceeds the maximum capacity, immediately remove the load and check that the platform has not been damaged

6.7.1 Programming Errors

Message	Description	Solution
<i>PrEC.</i>	Calibration error	First calibrate the zero point, then proceed with the next points
<i>Err.Pnt</i>	Calibration error	Check the connection of the load cell Check that the cell signal is stable, valid and greater than the previously acquired point
<i>Er 11</i>	Calibration error	Increase the calibration weight
<i>Er 12</i>	Calibration error	Check that the signal coming from the cell increases as the weight on the scale increases When acquiring the calibration points, use the increasing calibration weights
<i>Er 36</i>	Calibration error	Check that the signal coming from the load cell is not negative
<i>Er 37</i>	Calibration error	Repeat the calibration, checking that the capacity and division have been correctly set
<i>Er 38</i>	Calibration error	Capacity entered in the <i>rAnGE</i> parameter is not a multiple of the division set in the <i>dIU</i> step
<i>Er 39</i>	Instrument not configured	Reset factory configurations (menu <i>RdUPnE</i> , parameter <i>dFLtE</i> , Section 4.1.2 on page 31)
<i>Er 40</i>	Calibration error	Maximum capacity not set (<i>rAnGE=0</i>)
<i>Er 41</i>	Calibration error	Reset factory configurations (menu <i>RdUPnE</i> , parameter <i>dFLtE</i> , Section 4.1.2 on page 31)
<i>Er 85</i>	Instrument configured but not calibrated	Perform calibration
<i>Err. Plat</i> <i>rEtErYP</i>	Weight unstable	Check <i>AdE. uU</i> in the <i>d iAC</i> menu (Table 4-1 on page 30) that the signal is stable and retry if connection of the cells is with 4 wires, check that the sense jumpers are inserted
<i>bt. Err</i>	Bluetooth module error	The Bluetooth module is not responding (Section 6.8 on page 50)

6.8 Frequently Asked Questions

Communication Problems in a Wireless System

- Ensure there are no other devices communicating on the same frequencies
- Ensure there are no obstructions between the indicator and the platforms
- Turn the indicator outwards
- Reboot all the weigh pads and indicator
- Ensure there are no systems on the same frequency (868 MHz)

How to Increase the Accuracy of an Axle-Weighing System

The weighing accuracy in axle-weighing mode is influenced by several factors:

- Type of weighing area: it must comply with the leveling conditions ([Section 2.1 on page 5](#))
- Remove any unevenness between the axles by using the leveling modules or pit frames
- Vehicles with several axles close to each other require a surface that is leveled correctly
- Type of vehicle: vehicles with self-leveling suspensions can affect the weighing process; disable them if possible
- Transported load: the axle weighing process does not allow weighing vehicles that carry liquids
- If the system has been optimized for a direction of travel, using it in other direction might reduce the weighing accuracy

The Wheel Weigh Pad Will Bend When Loaded

The bending of the loaded weighing surface makes the operation of the load cells easier, thereby ensuring optimal weighing accuracy. Before installing the platforms, always remove any dirt and debris from the floor under the platform.

The Keypad is Locked / The Platform Does Not Turn Off

Nothing can be entered if the automatic keypad lock function has been activated, including turning off the platform. See [Section 3.1.1 on page 14](#) to unlock the keypad. See [Section 4.1.1 on page 31](#) to change parameter settings.

7.0 Appendix

7.1 Wheel Weigh Pad (RF-MD, RF-WD, RF-XWD) Dimensions

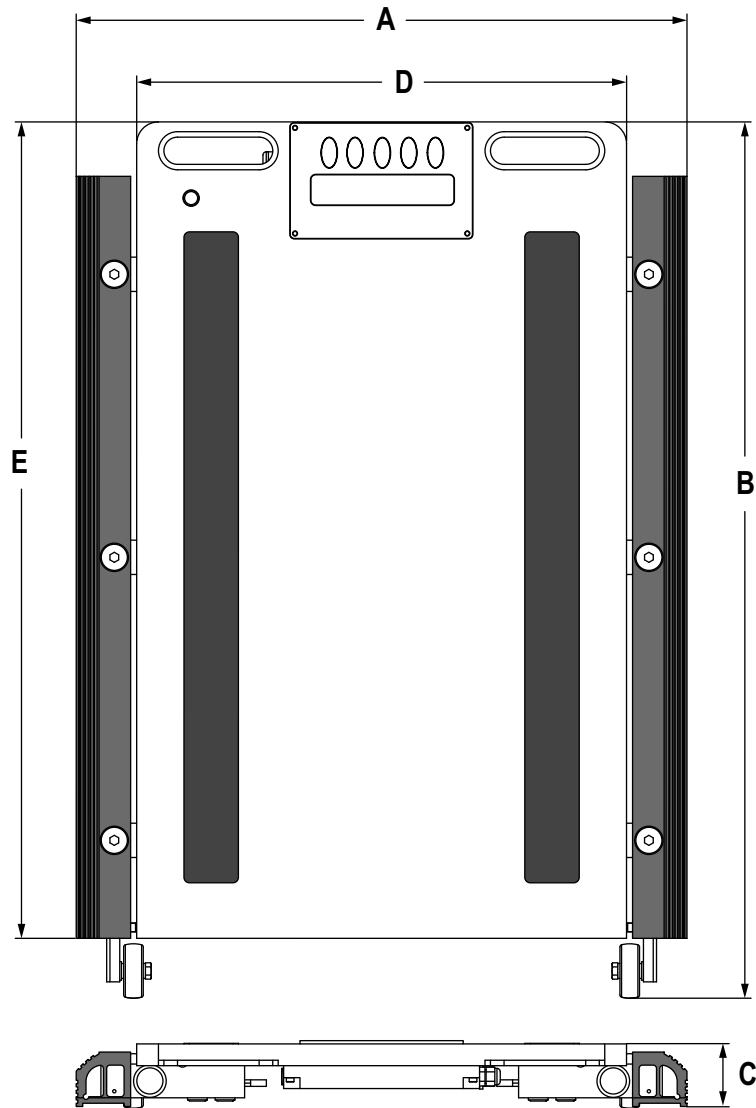

Figure 7-1. Wheel Weigh Pad Dimensions Diagram

Key	RF-MD	RF-WD	RF-XWD
A	1' 8"	1' 10"	2'
B	2'	2' 8"	3' 3"
C	2.28"	2.28"	2.28"
D	1' 4"	1' 6"	1' 8"
E	1' 10"	2' 6"	3' 1"

A, B and C represent the overall platform dimensions
D and E represent the loading surface dimensions

Table 7-1. Wheel Weigh Pad (RF-MD, RF-WD, RF-XWD) Dimensions

7.2 Replacement Parts

7.2.1 Wheel Weigh Pad (RF-MD, RF-WD, RF-XWD) Replacement Parts

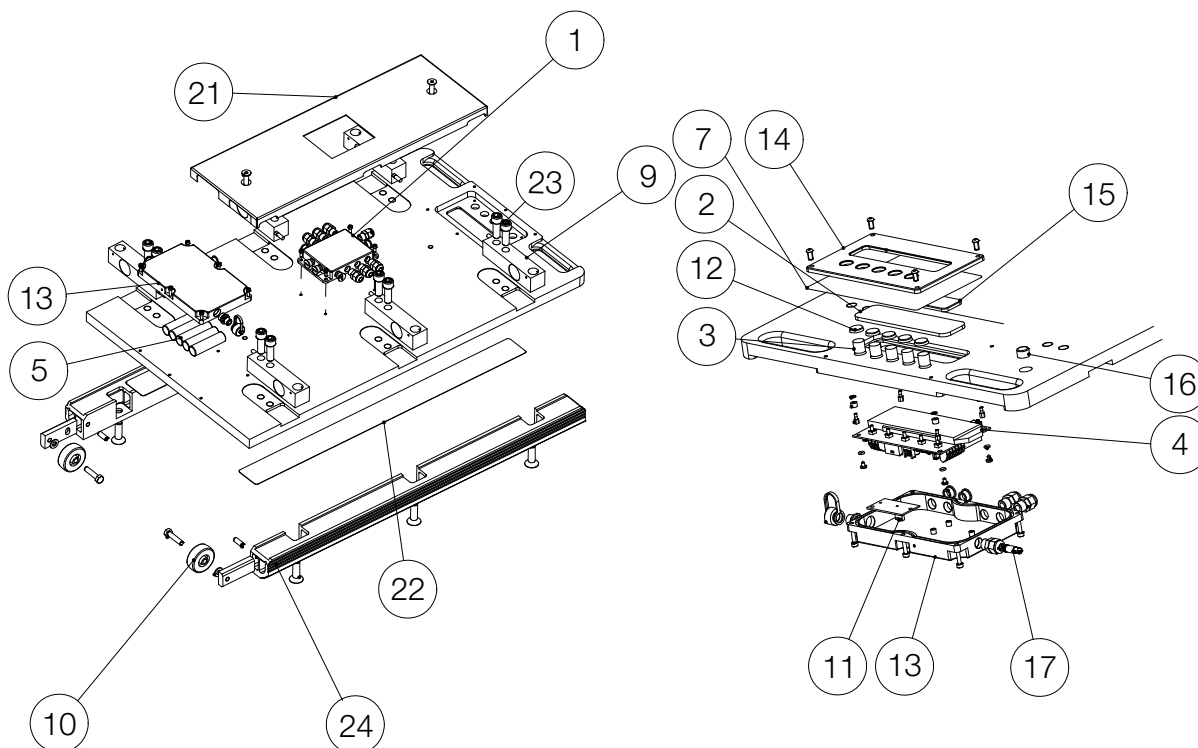

Figure 7-2. Wheel Weigh Pad (RF-MD, RF-WD, RF-XWD) Replacement Parts Diagram

Item No.	Part No.	Description
1	192596	Junction Box
2	192607	Protective Display Glass
3	192608	Extension Keys (Kit x 5) for RF-XWD
	192624	Extension Keys (Kit x 5) for RF-MD/RF-WD
4	192609	CPU Board
5	188482	NIMH Battery Pack
7	192616	Adhesive Film
9	183798	SBX2000 2,000 kg Load Cell
10	192605	Wheel
11	192610	Bluetooth Module
13	192614	Protection for Board
14	192615	Protection for Keys
16	192597	Bubble Level
17	200815	Antenna
NS	200816	Cable to Connect Antenna to Bluetooth Module
NS	188911	Battery Charger (230 VAC EU plug version)
NS	185064	110 VAC Version with US Plug
NS	-	Load Cell Terminal Strip
NS	194063	Battery Box Charger Connection Port, Green, Male Plug

Item No.	Part No.	Description
RF-MD		
21	192595	Protection Plate
22	192600	Adhesive Strip
NS	183796	1,000 kg Load Cell (Used on 3,000 lb Wheel Pad Only)
NS	183799	2,500 kg Load Cell (Used on 6,500 lb, 13,000 lb, 22,000 lb, 33,000 lb Wheel Pad Only)
23	192602	Load Cell Mounting Hardware
24	192598	Ramp with Gripping Rubber
RF-WD		
21	192618	Protection Plate
22	192601	Adhesive Strip
NS	183799	2,500 kg Load Cell (Used on 6,500 lb, 13,000 lb, 22,000 lb, 33,000 lb Wheel Pad Only)
23	192602	Load Cell Mounting Hardware
24	192598	Ramp with Gripping Rubber
RF-XWD		
21	192622	Protection Plate
22	192625	Adhesive Strip
NS	183799	2,500 kg Load Cell (Used on 6,500 lb, 13,000 lb, 22,000 lb, 33,000 lb Wheel Pad Only)
23	192604	Load Cell Mounting Hardware
24	192621	Ramp with Gripping Rubber

Table 7-2. Wheel Weigh Pad (RF-MD, RF-WD, RF-XWD) Replacement Parts

7.2.2 Load Ranger Ai-1 Replacement Parts

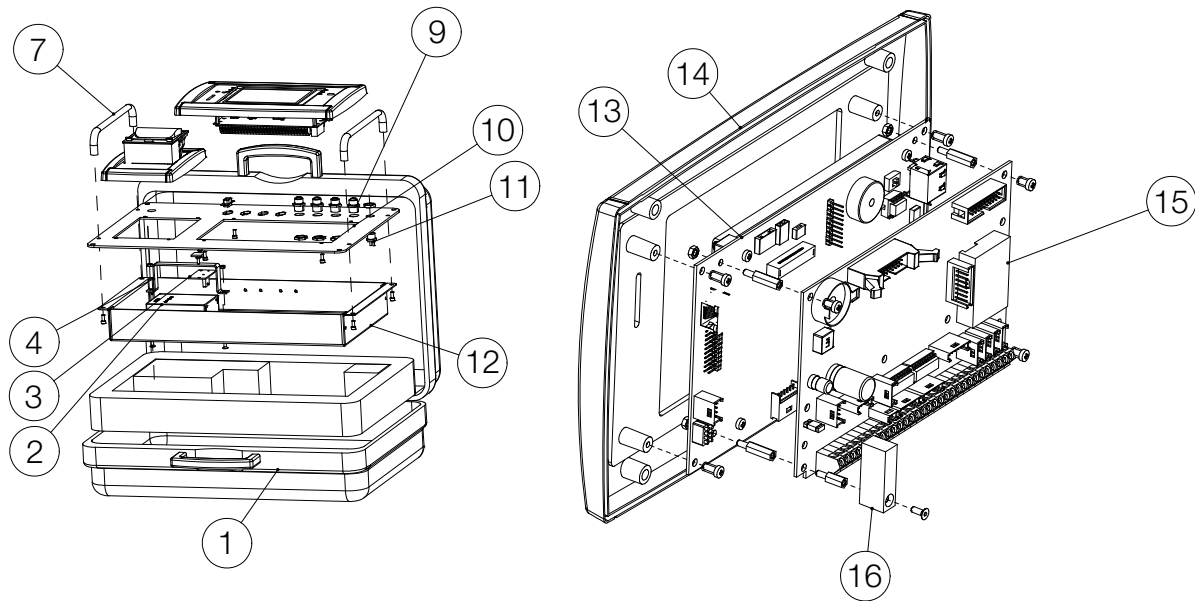

Figure 7-3. Load Ranger Ai-1 Replacement Parts Diagram

Item No.	Part No.	Description
1	192584	Carry Case
2	192580	Built-in Battery, 6 V, 4.5 Ah
3	193554	Built-in Bluetooth Interface
4	192588	Fixing Bracket for Battery
7	192582	Aluminum Handle
NS	193555	Bluetooth Board Connector Cable
10	192587	Front Panel
12	192581	Galvanized Case
13	192589	Display Board
14	192590	Front Panel
15	192585	CPU Board
16	192586	Frame, Jumper Protection
NS	194063	Battery Box Charger Connection Port, Green, Male Plug
NS	192591	Power Adapter 120-230 VAC

Table 7-3. Load Ranger Ai-1 Replacement Parts

7.3 Replacement Load Cells



Mod	Part No.	Load Cell	Qty.
Load Ranger RF-MD	181843	183796	4 pcs
Load Ranger RF-MD	181844	183799	4 pcs
Load Ranger RF-MD	181845	183799	4 pcs
Load Ranger RF-MD	181846	183799	6 pcs
Load Ranger RF-MD	181847	183799	6 pcs
Load Ranger RF-WD	181848	183799	6 pcs
Load Ranger RF-WD	181849	183799	6 pcs
Load Ranger RF-WD	181850	183799	6 pcs
Load Ranger RF-XWD	181853	183799	8 pcs
Load Ranger RF-XWD	181854	183799	10 pcs

Table 7-4. Replacement Load Cell Mods

Part No.	Capacity	Load Cell
183796	1000 kg	Shear Beam Approved Load Cell, C3, Max = 1000 kg; Nickered Steel, IP68 Protection Degree, 1000 Ohm output resistance
183799	2500 kg	Shear Beam Approved Load Cell, C3, Max = 2500kg; Nickered Steel, IP68 Protection degree, 1000 Ohm Output Resistance

Table 7-5. Replacement Load Cells

8.0 Compliance

	EU DECLARATION OF CONFORMITY <i>EU-KONFORMITÄTSERKLÄRUNG</i> <i>DÉCLARATION UE DE CONFORMITÉ</i>		Rice Lake Weighing Systems 230 West Coleman Street Rice Lake, Wisconsin 54868 United States of America 
	Type/Typ/Type: Load Ranger		
English	We declare under our sole responsibility that the products to which this declaration refers to, is in conformity with the following standard(s) or other regulations document(s).		
Deutsch	Wir erklären unter unserer alleinigen Verantwortung, dass die Produkte auf die sich diese Erklärung bezieht, den folgenden Normen und Regulierungsbestimmungen entsprechen.		
Français	Nous déclarons sous notre responsabilité que les produits auxquels se rapporte la présente déclaration, sont conformes à la/aux norme/s suivante ou au/aux document/s normatif/s suivant/s.		
EU Directive	Certificates	Standards Used / Notified Body Involvement	
2014/30/EU EMC	-	EN 61000-6-2:2015, EN 61000-6-4:2007+A1:2011, EN61326-1:2013, EN55011:2009 +A1:2010	
2014/35/EU LVD	-	EN 61010-1:2010	
2011/65/EU RoHS	-	EN 50581:2012	
Signature:	<u>Brandi Harder</u>		Place: <u>Rice Lake, WI USA</u>
Name:	<u>Brandi Harder</u>		Date: <u>November 16, 2021</u>
Title:	<u>Quality Manager</u>		

Form 1126 Rev.1 03/19

Approved by: Quality Department



UK DECLARATION OF CONFORMITY

Rice Lake Weighing Systems
230 West Coleman Street
Rice Lake, Wisconsin 54868
United States of America



Type: Load Ranger

English We declare under our sole responsibility that the products to which this declaration refers to, is in conformity with the following standard(s) or other regulations document(s).

UK Regulations	Certificates	Standards Used / Approved Body Involvement
2016/1091 EMC	-	EN 61000-6-2:2015, EN 61000-6-4:2007+A1:2011, EN61326-1:2013, EN55011:2009 +A1:2010
2016/1101 Low Voltage	-	EN 61010-1:2010
2012/3032 RoHS	-	EN 50581:2012

Signature: Brandi Harder

Place: Rice Lake, WI USA

Name: Brandi Harder

Date: February 8, 2022

Title: Quality Manager

9.0 Specifications

Construction

Aluminum alloy

Overall IP Rating

IP67 protection Rating

Display

Backlit LCD with 1" digits

Keyboard

Waterproof mechanical keyboard

Platform Dimensions (L x W x H)

Load Ranger RF-MD: 1' 10" x 1' 8" x 2.28"
(564 mm x 511 mm x 58 mm)

Load Ranger RF-WD: 2' 6" x 1' 10" x 2.28"
(750 mm x 561 mm x 58 mm)

Load Ranger RF-XWD: 3' 1" x 2' x 2.28"
(950 mm x 611 mm x 59 mm)

Loading Surface (L x W)

Load Ranger RF-MD: 1' 3" x 1' 4"
(403 mm x 400 mm)

Load Ranger RF-WD: 1' 11" x 1' 6"
(603 mm x 450 mm)

Load Ranger RF-XWD: 2' 5" x 1' 8"
(748 mm x 500 mm)

Weight

Load Ranger RF-MD: 40 lb (18.2 kg)

Load Ranger RF-WD: 62 lb (28.2 kg)

Load Ranger RF-XWD: 102 lb (46.3 kg)

System Accuracy

0.05% of rated capacity

Power Supply

Internal rechargeable battery (6 V - 4.5 Ah); Includes UL approved AC wall adapter

Approximately 40 hours of battery life for the wheel weigh pads
(approximately 12 hours of charge time)

Approximately 10 hours of battery life for the Ai-1 indicator

Operating Temperature

14°F to 104°F (-10°C to 40°C)

Storage Temperature

-4°F to 140°F (-20°C to 60°C)

Radio Frequency

Direct sequence spread spectrum at 2.4 GHz, license free 802.15.4

Connectivity

Built-in Bluetooth module (standard 4.0)

Effective Range

Up to 100' (30 m) line of sight typical

RS485 Port Connection

M12 female connector

Warranty

Two-year limited warranty

Approvals



NTEP

CC 20-003P Class III



NOTE: Select sizes and capacities only, consult factory for more information.

Radio Certificate Number

Bluetooth: US: PVH0946; Canada: 5325A-0946

WiFi: US: ZXVHLK-RM04



© Rice Lake Weighing Systems Specifications subject to change without notice.

230 W. Coleman St. • Rice Lake, WI 54868 • USA

U.S. 800-472-6703 • Canada/Mexico 800-321-6703 • International 715-234-9171 • Europe +31 (0)26 472 1319