

RL35023S Single-Ended Beam, Stainless Steel

NTEP 1:5000 Class III Multiple Cell, IP67

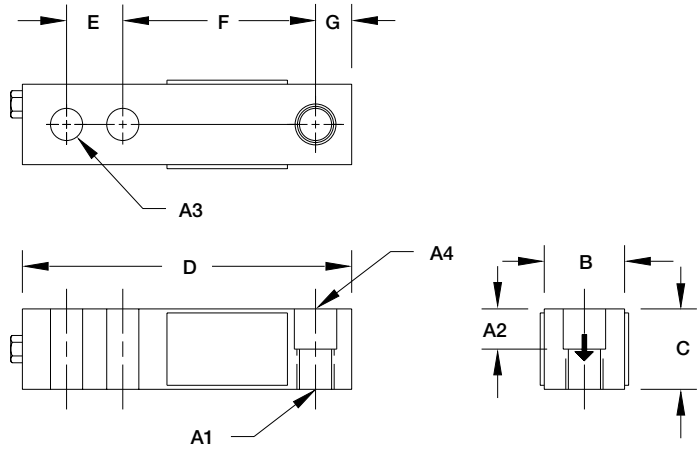

Picture is a representation of actual product

RATED CAPACITY	DIMENSIONS										
	A1	A2	A3	A4	B	C	D	E	F	G	
lb/inches											
1000-4000	1/2-20 UNF-2B	.62	.53	.53 DIA.	1.25	1.25	5.12	1.00	3.00	.50	
5000-10,000	3/4-16 UNF-2B	.75	.78	.78 DIA.	1.50	1.50	6.75	1.50	3.75	.75	
kg/mm											
453.6-1814.4	1/2-20 UNF-2B	15.8	13.5	13.5 DIA.	31.8	31.8	130.1	25.4	76.2	12.7	
2268.0-4535.9	3/4-16 UNF-2B	19.1	19.8	19.8 DIA.	38.1	38.1	171.5	38.1	95.3	19.1	

SPECIFICATIONS:

Full Scale Output:	3.0 mV/V	Insulation Resistance:	5000 megohms
Bridge Resistance:	350 ohms, nominal	Deflection at Capacity:	1000 lb = .013"/.33 mm, 2000-2500 lb = .015"/.38 mm, 4000-5000 lb = .025"/.64 mm, 10,000 lb = .032"/.81 mm,
Material/Finish:	Stainless steel	Seal Type:	Environmentally-sealed, IP67
Temperature:	Compensated range 14°F to 104°F/-10°C to 40°C	Cable Length:	20'/6.1 m
Safe Overload:	150% Full scale	Cable Coloring:	Red + Excitation Black - Excitation Green + Signal White - Signal
Rated Excitation:	10V DC (15V maximum)	Warranty:	Two-year limited warranty
Nonlinearity:	0.03% Full scale		
Hysteresis:	0.02% Full scale		

RL35023S ORDER INFORMATION

Load Rating	Part #	Price
1000 lb (453.6 kg)	30649	\$365.00
2000 lb (907.2 kg)	30650	\$365.00
2500 lb (1134.0 kg)	30651	\$365.00
4000 lb (1814.4 kg)	30652	\$365.00
5000 lb (2268.0 kg)	30653	\$430.00
10,000 lb (4535.9 kg)	30654	\$430.00
Conduit Adapter Kit* (must be factory installed to maintain warranty)		
3/8-24 Nipple	31533*	\$27.00
3/8-24 to 1/4-18 NPT	31534*	\$27.00

* Parts #31533 and #31534 must be installed together to form the Conduit Adapter Kit

INTERCHANGEABLE PRODUCTS

Manufacturer	Model
Vishay Sensortronics	(see page 303) 65023 S
Vishay Sensortronics	(see page 302) 65023 SS

WEIGH MODULE AVAILABLE

Model	Page #
RL50210 TA	32
RL1800 Series	44