

# MSI-6260CS TRANS-WEIGH

## RF DIGITAL CRANE SCALE

### Options and Accessories

- Universal direct power supply; 85-265VAC, 47-440Hz/130-300VDC
- Substitute shackle for bottom swivel hook (for possible headroom loss reduction)
- Oversized top lifting eye or shackle (for oversized crane hook interface)
- Oversized bottom swivel hook
- Low headroom adapter (for in-block installation)
- Anti-heat shielding (for high temperature mill and foundry applications)
- Ethernet 802.11b/g connectivity
- NTEP Certified
- Retrofit Kit for converting existing MSI-4260 and MSI-6260 crane scales to MSI-6260CS CellScale configuration

### MSI-6260CS Dimensions

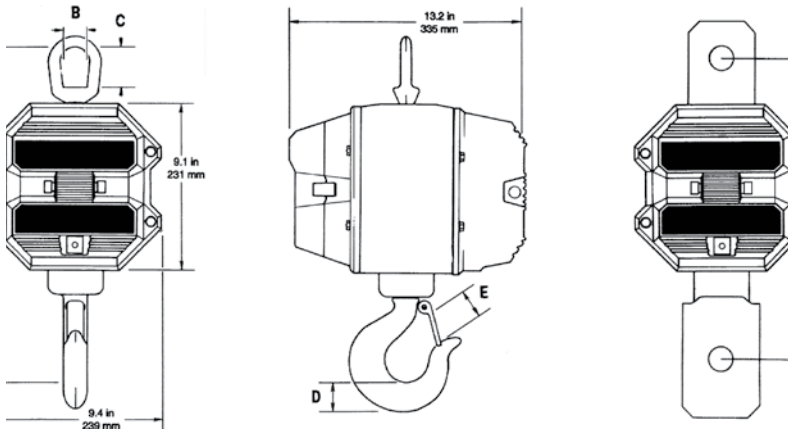

Note: 50/70/100,000lb models come standard with top shackle and bottom swivel hook.

Capacity	Resolution**	A*	B*	C*	D*	E*	F	Hook	Eye Nut or Shackle	Shipping Weight
500 lb 250 kg	0.2 lb 0.1 kg	18.3 in 465 mm	2.25 in 57.1 mm	3.06 in 77.7 mm	1.44 in 37.0 mm	1.41 in 36.0 mm	—	5 ton alloy swivel	CR # 7 eye nut	53 lb 24 kg
2,000 lb 1,000 kg	1 lb 0.5 kg	18.3 in 465 mm	2.25 in 57.1 mm	3.06 in 77.7 mm	1.44 in 37.0 mm	1.41 in 36.0 mm	—	5 ton alloy swivel	CR # 7 eye nut	53 lb 24 kg
5,000 lb 2,500 kg	1 lb 0.5 kg	20.5 in 521 mm	2.50 in 64.0 mm	3.50 in 89.0 mm	1.81 in 46.0 mm	1.69 in 42.9 mm	—	7 ton alloy swivel	CR #8 eye nut	62 lb 28 kg
10,000 lb 5,000 kg	2 lb 1 kg	20.5 in 521 mm	2.50 in 64.0 mm	3.50 in 89.0 mm	1.81 in 46.0 mm	1.69 in 42.9 mm	—	7 ton alloy swivel	CR # 8 eye nut	62 lb 28 kg
20,000 lb 10,000 kg	5 lb 2 kg	28.5 in 724 mm	4.00 in 101.6 mm	6.25 in 159 mm	2.62 in 66.5 mm	2.41 in 61.2 mm	—	15 ton alloy swivel	CR # 11 eye nut	105 lb 47 kg
30,000 lb 15,000 kg	10 lb 5 kg	30.0 in 762 mm	4.00 in 101.6 mm	6.25 in 159 mm	3.00 in 76.2 mm	3.19 in 81.0 mm	—	22 ton alloy swivel	CR # 11 eye nut	125 lb 55 kg
50,000 lb 25,000 kg***	10 lb 5 kg	41.0 in 1041 mm	5.00 in 127 mm	6.00 in 152 mm	3.62 in 92.0 mm	3.63 in 92.0 mm	15.0 in 381 mm	30 ton alloy swivel	CR 25 ton shackle # 2130	235 lb 106 kg
70,000 lb**** 35,000 kg****	20 lb 10 kg	43.2 in 1097 mm	5.00 in 127 mm	6.00 in 152 mm	4.56 in 116 mm	3.75 in 95.0 mm	15.0 in 381 mm	37 ton alloy swivel	CR 40 ton shackle # 2140	270 lb 121 kg
100,000 lb***** 50,000 kg*****	20 lb 10 kg	52.1 in 1324 mm	5.75 in 146 mm	6.65 in 169 mm	5.06 in 129 mm	4.25 in 108 mm	16.25 in 413 mm	CR 45 ton S1 swivel	CR 55 ton shackle # 2140	420 lb 189 kg

CONSULT FACTORY FOR HIGHER CAPACITIES – See MSI-9300HT specification sheet for applications that require fixed hooks and/or use with powered rotators.

CR = Crosby® or equivalent (Crosby is a registered trademark of The Crosby Group, LLC.)

- \* These dimensions also apply to 50/70/100,000lb models with hook and shackle
- \*\* Resolution subject to change for NTEP Certified units
- \*\*\* Ultimate overload: 490% of kg capacity
- \*\*\*\* Ultimate overload: 475% of lb capacity / 430% of kg capacity
- \*\*\*\*\* Ultimate overload: 450% of kg capacity

Your Rice Lake Weighing Systems distributor is:

**RICE LAKE**  
WEIGHING SYSTEMS

230 W. Coleman St. • Rice Lake, WI 54868 • USA  
TEL: 715-234-9171 • FAX: 715-234-6967 • [www.ricelake.com](http://www.ricelake.com)

An ISO 9001 registered company © 2017 Rice Lake Weighing Systems PN 154318 11/17  
Specifications subject to change without notice.

### Specifications

- Accuracy:** ± (0.1% +1 d) of applied load
- Resolution:** 3000 to 5000 d standard (up to 10,000 d available)
- Enclosure:** NEMA 4 IP66, marine grade 356 alloy anodized cast aluminum
- Lifting Eye, Shackle & Hook:** Crosby® or equivalent with 360° thrust-bearing swivel hook
- Design Overload:** 200% safe / 500% ultimate (except as noted)
- Functions:** POWER on/off (all other scale functions are controlled from other optional networked MSI scale indicators, MSI-9850 and/or MSI-9750A)
- Displayable Units:** Pounds or kilograms selectable
- Power:** 12 volt rechargeable battery, 115/230VAC battery charger included
- Operating Time:** Up to 40 hours between charging with typical use
- Operating Temperature:** -4°F to 158°F (-20°C to 70°C)
- Calibration:** Digital via MSI-9750A or MSI-9850 RF indicators or via serial interface with PC terminal program
- Radio Link:** FHSS at 2.4 GHz (up to 64 network selections)
- Radio Link Effective Range:** Typically 500 ft (150 m) indoor, 1000 ft (300 m) outdoor with standard antennas
- Approvals:** NTEP CC 07-007

# MSI-6260CS Trans-Weigh

RF DIGITAL CRANE SCALE

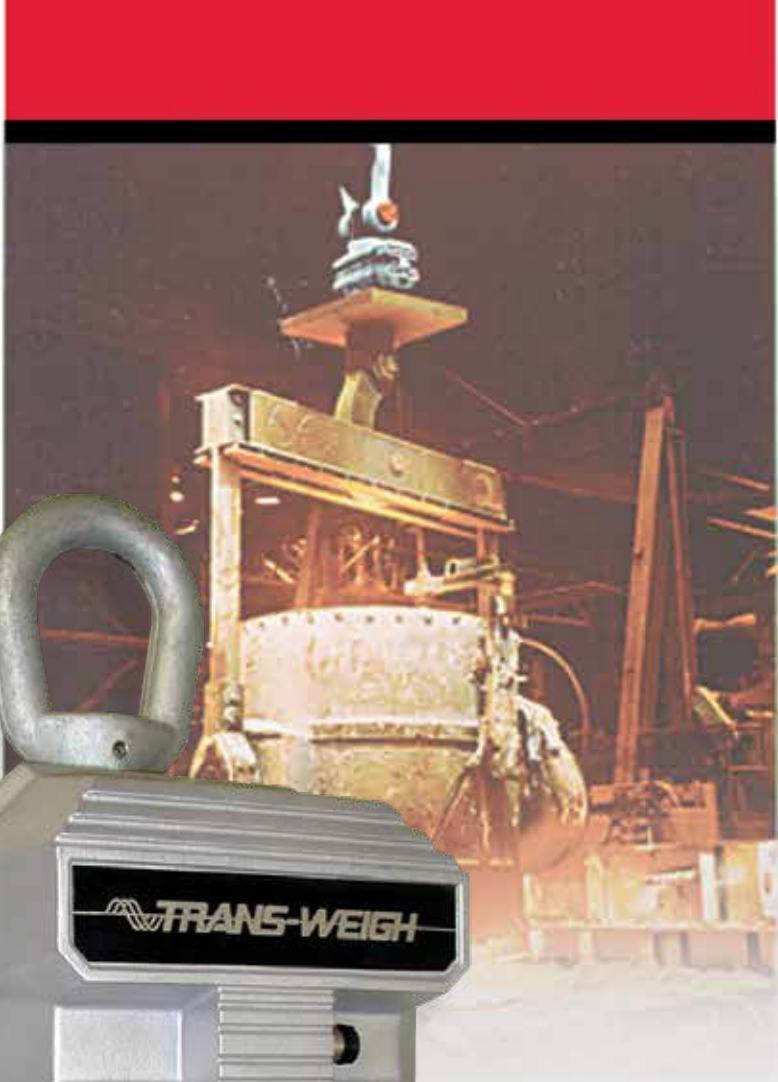

COMPATIBLE WITH:



MSI-9750A



MSI-9850



LaserLight2 Remote Display



MSI-9020

**RICE LAKE**  
WEIGHING SYSTEMS

800-874-4320  
[www.ricelake.com/msi](http://www.ricelake.com/msi)

# The MSI-6260CS Trans-Weigh features wireless connectivity for application in automated industrial weighing and process control installations.

The MSI-6260CS RF is a key member of the MSI CellScale™ product family and a world-renowned industrial grade crane scale featuring RF wireless connectivity with nearly all types of plant information systems. When networked with other CellScale components, the MSI-6260CS provides enhanced system solutions for advanced wireless data collection and transfer in industrial material weighing as well as process control applications.

MSI-6260CS integrated with CellScale technology enables single or multiple crane scales to be controlled and monitored safely and efficiently from MSI's RF remote indicators MSI-9850 and MSI-9750A. Wireless, real-time transmission of weight and product information may be processed through a system-configured network of CellScale components from distances up to 1000 feet (300 m). Operating ranges can be further increased when optional long-range antennas are configured with other networked CellScale components. Both fixed and handheld digital weight indicators are available as well as RF modems for wireless connectivity to peripheral computers and scoreboards. Optional 802.11b/g Ethernet connectivity is also supported for adaptation with existing plant information systems.

Ideal for use in demanding industrial applications and environments, the MSI-6260CS is available in a standard range of capacities up to 50 tons. Larger capacity and application specific designs are also available on request. All electronics are securely shock mounted in a robust NEMA4/IP66 marine grade enclosure. Additional options are also available for mill and foundry use over high-temperature ladle installations.

Also see specifications for other CellScale family components complementing the MSI-6260CS including: MSI-9750A, MSI-9850, RF indicators, MSI-9000, MSI-9020, RF scoreboards and MSI-9300 and MSI-9300HT crane scales. The MSI-9300 and MSI-9300HT provide all of the same features and benefits of the MSI-6260CS plus an integrated digital display and fixed hook options for use with powered rotating hooks or special installations. MSI CellScale products provide configurable system solutions to satisfy nearly any wireless weighing application.

## Optional Components



MSI-9750A



MSI-9300



MSI-9020



MSI-9850

# Wireless connectivity Scaling



MSI-6260CS  
Wireless  
Communication  
with CellScale  
Crane Scales  
and Peripherals

LaserLight2 Remote Display



## Optional MSI-6260CS Retrofit Kit

MSI-6260CS Retrofit Kit integrates CellScale technology with existing MSI-4260 Port-A-Weigh Plus and MSI-6260 Trans-Weigh crane scales.

The retrofit kit replaces the existing front casting and electronics section of both models MSI-4260 and MSI-6260. After conversion, the new MSI-6260CS adapts easily into any CellScale network.