

1280 Enterprise Series

Dual A/D Scale Card Installation

The Dual A/D Scale Card (PN 164683) provides two additional scale channels. The 1280 can support up to eight scales. The configuration of each scale is stored both on the card and in the indicators memory. The CPU board will rewrite the calibration to the A/D scale card if replacing or swapping installed cards.



Manuals can be viewed and downloaded from the Rice Lake Weighing Systems website at www.ricelake.com

Warranty information can be found on the website at www.ricelake.com/warranties

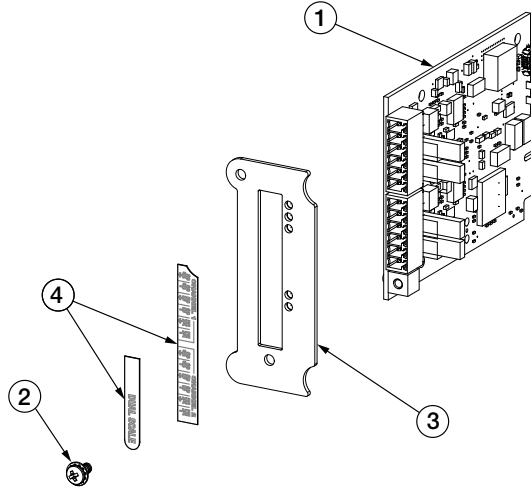

Figure 1. Dual A/D Scale Card Kit

Item No.	Part No.	Description	Qty.
1	160760	Board Assembly, Dual A/D	1
2	14822	Screw, Machine 4-40 NC x 1/4	1
3	164676	Face Plate, Option Card	1
4	167194	Label, Dual Scale A/D	1

Table 1. Dual A/D Scale Card Kit Parts List

The included parts kit contains items used for installation of the card. Items listed for stud grounding of the shields pertain to the panel mount enclosure. See the 1280 technical manual (PN 167659) for more information on grounding the shield with the cord grip.

Part No.	Description	Qty.
14621	Nut, Kep 6-32NC HEX (used for stud grounding)	2
14822	Screw, Mach 4-40 NCx1/4 (secures card to controller assembly)	1
15130	Washer, lock No. 6 Type A (used for stud grounding)	2
153883	Connector, 6 position screw terminal (interface connector)	2
15631	Cable tie, 3 inch nylon (secures cable in panel mount installation)	4
53075	Clamp, ground cable shield (used for stud grounding)	2
94422	Label, capacity .40 X 5.00 (used with dual scale A/D scales)	2
166957	Regulatory seal for the A/D card to prevent removal. 158208 - Screw, mach 4-40 x 3/8 (2) 165927 - Clip, load cell locking (1)	1
171801	Ferrite core, snap on (clips onto the load cell cable)	2

Table 2. Parts Kit (PN 163784)



WARNING: Always disconnect power before opening the indicator. Option card is not hot swappable.



CAUTION: Use a wrist strap to ground yourself and protect components from electrostatic discharge (ESD) when working inside the indicator enclosure.

1. Open the indicator as instructed in the 1280 technical manual.
2. Remove a slot cover plate from the controller assembly to open a slot for the card.
3. Remove protective tape from pins J3 on the option card prior to installation. Make sure the pins are clean of any sticky residue by carefully wiping with rubbing alcohol.
4. Ensure S1 switch on the card is in the *Run* position (Figure 2).
5. Align the card to the slot; the screw hole in the faceplate of the card should align with the screw hole on the controller assembly.
6. Slide the card into the top and bottom grooves of the slot. Push the card until it is securely seated in the back plane.
7. Secure with screw 4-40 NC x 1/4 (provided).
8. To attach the cable from the scale to the A/D scale card, route the cable through the cord grip.
9. For Channel 1, wire the load cell cable from the scale to the connector (from the parts kit) for J1 as shown in Figure 2 and Table 3.
10. For Channel 2, wire the load cell cable from the scale to the connector (from the parts kit) for J2 as shown in Figure 2 and Table 3.



NOTE: To use a 6-wire load cell cable (with sense wires), remove jumpers JP1 and JP2 before installing the card into the slot. To use 4-wire connections, leave jumpers JP1 and JP2 on. Remove jumpers JP3 and JP4 for 6-wire connections to J2.

11. When connections are complete, install load cell connector on the A/D scale card.



NOTE: A sealing clip can be installed over the over the connector to provide a hardware seal that allows access while preventing removal of the scale card and connector.

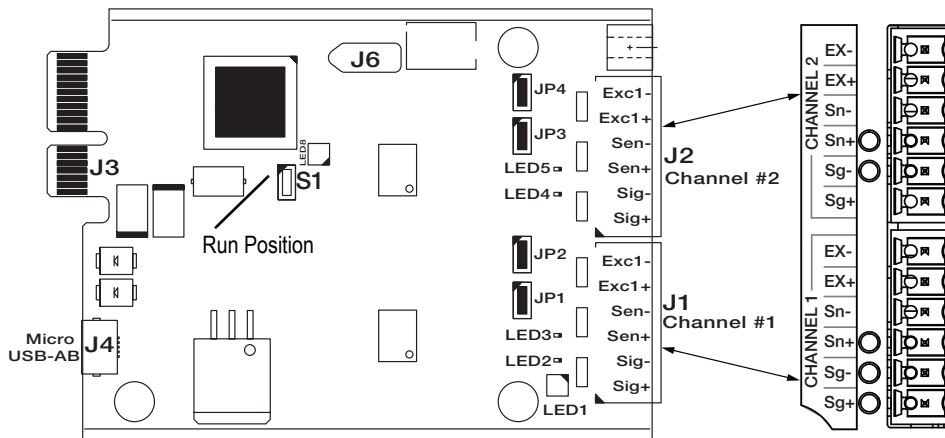

Figure 2. Dual A/D Scale Card

J1/J2	Channel #1/Channel #2
Pin 1	SIGNAL +
Pin 2	SIGNAL -
Pin 3	SENSE +
Pin 4	SENSE -
Pin 5	EXCITATION +
Pin 6	EXCITATION -

* For 6-wire load cell connections to connector J1, remove jumpers JP1 and JP2.
 * For 6-wire load cell connections to connector J2, remove jumpers JP3 and JP4.

Table 3. Pin Assignments



NOTE: The slot of the controller assembly that is selected for the installation of the card will determine the scale channels that can be associated to a scale number.

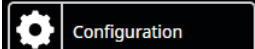

Slot 1 = Slot 1 Channel 1 Slot 1 Channel 2	Slot 4 = Slot 4 Channel 1 Slot 4 Channel 2
Slot 2 = Slot 2 Channel 1 Slot 2 Channel 2	Slot 5 = Slot 5 Channel 1 Slot 5 Channel 2
Slot 3 = Slot 3 Channel 1 Slot 3 Channel 2	Slot 6 = Slot 6 Channel 1 Slot 6 Channel 2

Table 4. Associated Scale Channels

12. Use cable ties from the parts kit to secure loose cables inside the enclosure as needed. Ensure no excess or loose cable is left inside the enclosure.
13. Ground the shield cable using the ground washer in the metal cord grip, or use the grounding stud on the enclosure with cable clamp included in the parts kit. See the 1280 technical manual for more information.
14. Tighten cord grips. Ensure cord grip nut is also tight.
15. Reassemble and power the indicator.
16. Press  on the weigh mode screen. The **Main Menu** displays.
17. Press  for access to the Configuration menu.



NOTE: Access to the Configuration menu may be restricted. Refer to the 1280 technical manual for more information.

18. To configure the scale channel, select  to enter the scales menu.
19. Select the scale number (1-8) to be configured from the selection field drop down list.
20. Select  and set the scale to **Analog Load Cell Scale**. The **Select Scale Hardware** screen displays.
21. Select the slot and channel to associate the available hardware for the scale being configured.
22. See the 1280 technical manual for calibration.

LED Status Indicators

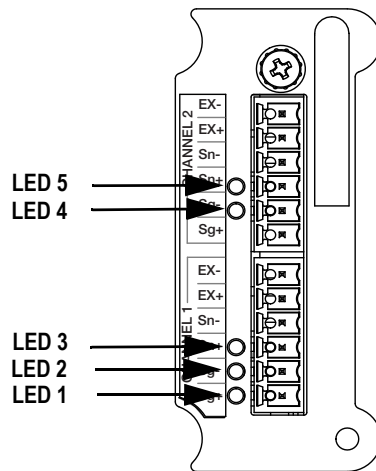

Figure 3. Dual A/D Scale Card Faceplate

LED	Status
1	Green flashing indicates card it is working. Red indicates it is faulty
2	Green indicates a load cell is connected and configured correctly
3	Not used
4	Green indicates a load cell is connected and configured correctly on channel 2
5	Not used

Table 5. LED Status Lights

Specifications

Excitation Voltage	10 ± 0.5 VDC, 16 x 350Ω or 32 x 700Ω load cells per A/D card
Sense Amplifier	Differential amplifier with 4- and 6-wire sensing
Analog Signal Input Range	-60 mV/V to +60 mV/V
Analog Signal Sensitivity	0.3 uV/grad minimum @ 7.5 Hz 1.0 uV/grad typical @ 120 Hz 4.0 uV/grad typical @ 960 Hz
A/D Sample Rate	7.5–960 Hz, software selectable
Input Impedance	>35 MΩ typical
Internal Resolution	8 million counts/8,000,000
Weight Display	1,000,000
Input Sensitivity	10 nV per internal count
System Linearity	±0.01% of full scale
Zero Stability	±150 nV/°C, maximum
Span Stability	± 3.5 ppm/°C, maximum
Input Voltage Differential	±800 mV referenced to earth ground



© Rice Lake Weighing Systems Specifications subject to change without notice.

230 W. Coleman St. • Rice Lake, WI 54868 • USA
U.S. 800-472-6703 • Canada/Mexico 800-321-6703 • International 715-234-9171 • Europe +31 (0)26 472 1319