

Hanging Scales

TABLE OF CONTENTS

On-site OS-10/OS-25/OS-45	418
<i>Suspended Scale</i>	

Product names, logos, brands and other trademarks featured or referred to within this publication are the property of their respective trademark holders.

On-site OS-10/OS-25/OS-45

Suspended Scale



Standard Features

- Hold function
- Units of measure: lb/lb-oz/kg
- Adjustable automatic shut-off
- Ergonomic handheld design
- Battery operated, two AA batteries included
- Carrying case and top s-hook included
- Captured lower hook, removable upper hook (included)

Specifications

Capacity:

OS-10:
 22 lb × 0.02 lb
 22 lb × 0.25 oz
 10 kg × 0.01 kg

OS-25:
 55 lb × 0.05 lb
 55 lb × 0.5 oz
 25 kg × 0.02 kg

OS-45:
 99 lb × 0.1 lb
 99 lb × 1 oz
 45 kg × 0.05 kg

Power:

Two AA batteries (included)

Operating Temperature:

32 °F to 104 °F (0 °C to 40 °C)

Warranty:

One-year limited

Approvals:

CE Marked

Approvals



Part Number/Price

Part #	Model	Capacity	Est. Weight	Price
130292	OS-10	10 kg × 0.01 kg (22 lb × 0.02 lb) (22 lb × 1/4 oz)	1.25 lb	\$90.00
130293	OS-25	25 kg × 0.02 kg (55 lb × 0.05 lb) (55 lb × 1/2 oz)	1.25 lb	\$90.00
130294	OS-45	45 kg × 0.05 kg (99 lb × 0.1 lb) (99 lb × 1 oz)	1.25 lb	\$90.00

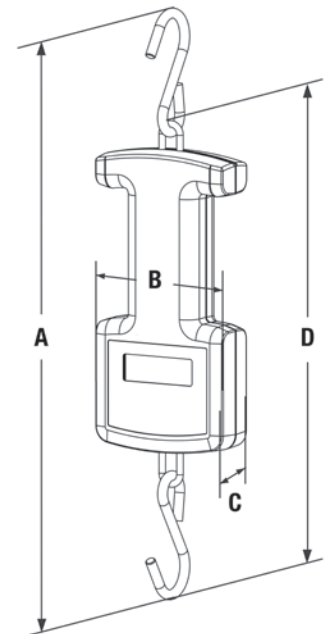

Dimensions

	Inches	Centimeters
A	14.3	36.3
B	3.6	9.2
C	1.3	3.2
D	11.6	29.4

HANGING SCALES

