

# Aviation

---

## TABLE OF CONTENTS

<b>Tracer® AV2</b> .....	<b>38</b>
<i>Baggage Weighing Instrumentation</i>	

*The following product names, logos, brands and other trademarks featured or referred to within this publication are the property of their respective trademark holders.*

# Tracer® AV2

Baggage Weighing Instrumentation



## Approvals



Ideal for baggage weighing, Tracer AV2 combines a sleek five-button keypad with the most durable stainless steel display. The simple-to-install display features a large, backlit LCD display and the rugged keypad will endure years of busy check-in counter use.

## Part Number/Price

Part #	Description	Price
202532	Tracer AV2, single LCD panel mount display, single keypad	\$1,945.00
202531	Tracer AV2, dual LCD panel mount display, single keypad	\$2,345.00
207287	Tracer AV2, dual LCD panel mount display, dual keypad	\$2,445.00
204452	Tracer AV2, single LCD external mount display, single keypad	\$1,995.00
204451	Tracer AV2, dual LCD external mount display, Single keypad	\$2,495.00

To complete your system, refer to page 180 for the BenchMark LP or page 181 for the BenchMark HD scales

## Replacement Parts

Part #	Description	Price
205206	Tracer AV2 CPU module	\$1,045.00
207288	Kit, RD2 LCD display	\$475.00
207289	Kit, RD2 LCD display, external mount package	\$525.00
207290	Kit, five-button keypad	\$195.00
15438	Power cord, detachable, 7.5 ft long	\$20.00
203937	Power supply, 7.5V 30W	\$155.00
207302	Cable splitter, DB9 female to DB9 male connector	\$10.00

## Standard Features

- Customer display (panel mount)
- CPU module
- Supports two displays (customer/agent)
- Five-button keypad for ticket agent
- Accumulation function
- Display indicates overweight bag

## Specifications

### Power:

115 to 230 VAC to CPU module  
50/60 Hz

### Power Consumption:

6 W

### Excitation Voltage:

5 VDC, 8 x 350 ohm load cells

### Analog Signal Input Range:

-0.5 mV/V to 4.5 mV/V

### Analog Signal Sensitivity:

1 µV/graduation recommended

### A/D Sample Rate:

6.25 to 120 Hz, software selectable

### Resolution:

Internal: 8,000,000 counts  
Display: 1,000,000

### System Linearity:

Within 0.01% full scale

### Communication:

Ethernet TCP/IP  
USB Device

### Annunciators:

lb/kg

### Display:

Stainless steel, panel mounted, seven-digit LCD display, 0.8 in (20 mm) tall digits

### Keys/Buttons:

Zero, Units, Accum, Print, Enter

### Temperature Range:

14 °F to 104 °F (-10 °C to 40 °C)

### Dimensions:

#### Panel Mount Display:

7.5 × 4.0 × 1.49 in  
(19.05 × 10.16 × 3.79 cm)

#### External Mount Display:

7.5 × 3.9 × 1.44 in  
(19.05 × 9.91 × 3.66 cm)

#### Panel Mount Keypad:

4.0 × 2.5 × 2.1 in  
(10.16 × 6.35 × 5.33 cm)

#### CPU Enclosure:

7.5 × 7.0 × 2.25 in without mounting feet  
11.13 × 7.0 × 3.06 in with mounting feet

### Weight:

5.25 lb

### Warranty:

Two-year limited

### Approvals:

NTEP CC 21-015, Class III/IIIL, 10,000d  
Measurement Canada AM-6168C  
cULus Listed

Dimensions			
CPU Enclosure Assembly			
A	7.30 in (18.55 cm)	F	11.10 in (28.20 cm)
B	7.00 in (17.78 cm)	G	2.40 in (6.10 cm)
C	3.20 in (8.13 cm)	H	10.0 in (25.40 cm)
D	8.00 in (20.32 cm)	I	4.50 in (11.43 cm)
E	7.50 in (19.05 cm)		

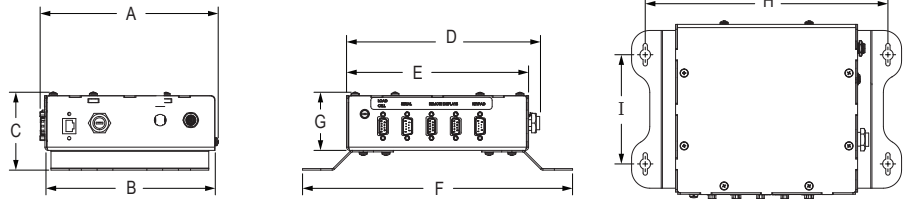

Dimensions			
Remote Keypad (Panel Mount)			
A	4.00 in (10.16 cm)	E	1.90 in (4.83 cm)
B	2.50 in (6.35 cm)	F	1.38 in (3.51 cm)
C	1.98 in (5.03 cm)	G	4.63 in (11.76 cm)
D	0.063 in (0.16 cm)	H	2.60 in (6.61 cm)

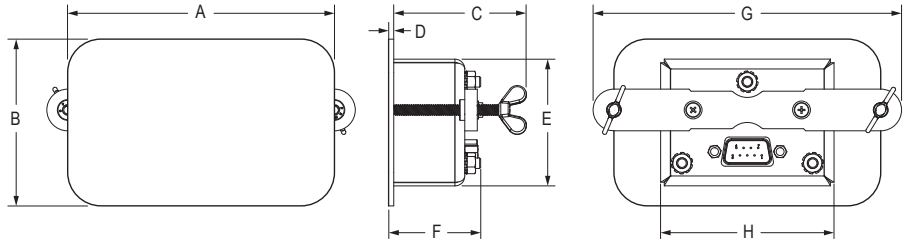

Dimensions			
Remote Display (Panel Mount)			
A	7.50 in (19.05 cm)	E	1.00 in (2.54 cm)
B	4.00 in (10.16 cm)	F	0.063 in (0.16 cm)
C	7.00 in (17.78 cm)	G	1.33 in (3.38 cm)
D	2.22 in (5.64 cm)	H	1.49 in (3.79 cm)

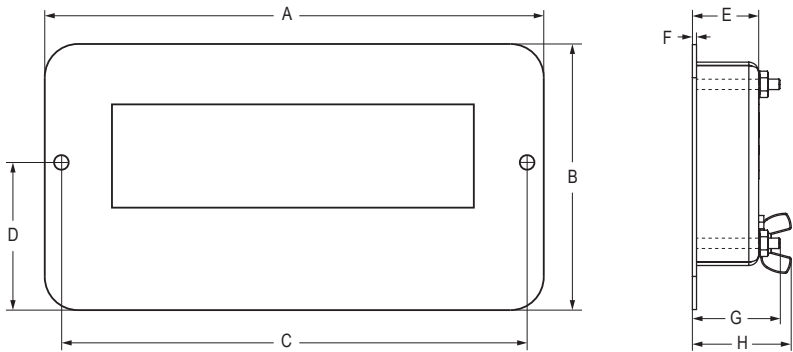

Dimensions			
Remote Display (External Mount)			
A	7.50 in (19.05 cm)	E	1.44 in (3.66 cm)
B	3.90 in (9.91 cm)	F	1.29 in (3.28 cm)
C	6.22 in (15.80 cm)	G	1.00 in (2.54 cm)
D	1.95 in (4.96 cm)		

