

# Ready-n-Weigh Bench Scale System

CW-90XB Bench Scale and 380 Indicator Package

BENCH SCALES



## Approvals



Measurement  
Canada  
Approved



## CW-90XB with 380 Package

Part #	Capacity	Dimensions (L × W × H)	Est. Weight	Price
208543	5 lb (2.5 kg)	10 × 10 × 4.25 in	24 lb	Consult
208544	10 lb (5 kg)	10 × 10 × 4.25 in	24 lb	Consult
208545	25 lb (10 kg)	10 × 10 × 4.25 in	24 lb	Consult
208546	25 lb (10 kg)	12 × 12 × 4.25 in	27 lb	Consult
208547	50 lb (25 kg)	12 × 12 × 4.25 in	27 lb	Consult
208548	100 lb (50 kg)	12 × 12 × 4.25 in	27 lb	Consult

## Options/Accessories

Part #	Description	Price
206433†	External AC adapter	Consult
204258	Real-time clock module	Consult



† US plug (NA) - Type A

## Dimensions

CW-90XB Bench Scale and 380 Indicator			
10 × 10 in			
A	19.56 in	E	9.44 in
B	10.20 in	F	4.25 in
C	14.02 in	G	10.20 in
D	13.36 in		

Note: 1 in = 25.4 mm

12 × 12 in			
A	19.56 in	E	9.31 in
B	12.29 in	F	4.25 in
C	16.07 in	G	12.29 in
D	13.23 in		

Note: 1 in = 25.4 mm

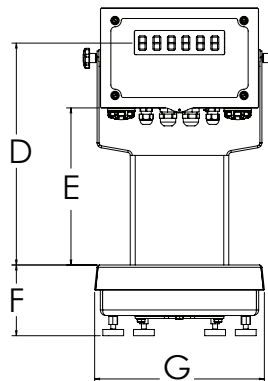
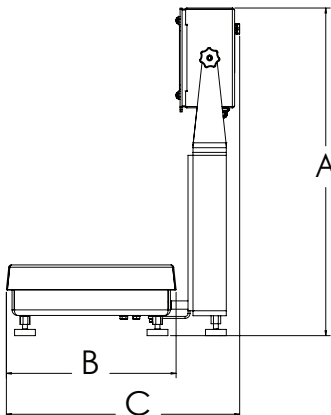

## Standard Features

- Package includes scale, NTEP Certified load cell, indicator and 12-inch column
- Factory calibrated with indicator setup and configured for 5,000 divisions
- Scale includes rubber feet to provide exceptional traction and avoid scratching surfaces along with a removable top cover for ease of cleaning
- Optional battery backed time and date
- Standard RS-232 serial port for connecting to a variety of peripherals
- Powered by four alkaline C-cell batteries (not included) or external AC adapter (not included)

## CW-90XB Specifications

### Load Cell:

IP69K, hermetically sealed  
Stainless steel

### Scale Construction:

304 stainless steel

### Maximum Overload:

180% to 200% depending on capacity

### Overload Protection:

Five-point, independently adjusted

### Scale Frame:

AISI304L, straight line finish, Ra = 45 ± 10

### Scale Cover:

AISI304L, straight line finish, Ra = 45 ± 10

### Cable Length:

34 in (86 cm)

### Temperature:

Compensated:  
14 °F to 104 °F (-10 °C to 40 °C)

### Warranty:

Three-year limited  
(includes water ingress)

### Approvals:

NTEP 95-072, Class III 5,000 d  
Measurement Canada AM-5082  
Load cell is NTEP  
Load cell is FM approved

## 380 Specifications

### Power:

Batteries: Four alkaline C-cell (not included)  
Optional: 115/230 VAC to 12 VDC adapter

### Battery Life:

100 hours on alkaline batteries with one 350 ohm load cell, no backlight

### Communication Ports:

One full-duplex RS-232 (three-wire)  
One USB 2.0

### Display:

Six 1 in (25 mm) tall, LCD digits

### Status Annunciators:

g, lb, t, tn, kg, oz, battery level, PT, LT, gross, zero, unstable, net

### Keys/Buttons:

Five tactile buttons

### Rating/Material:

IP66, 304 Stainless steel

### Warranty:

Two-year limited

### Approvals:

NTEP 21-051  
Measurement Canada AM-6184  
CE Marked  
cULus Listed