

RoughDeck®

*Low Profile Floor Scale
HP, HP-H, HC and Rough-n-Ready*

Installation Manual

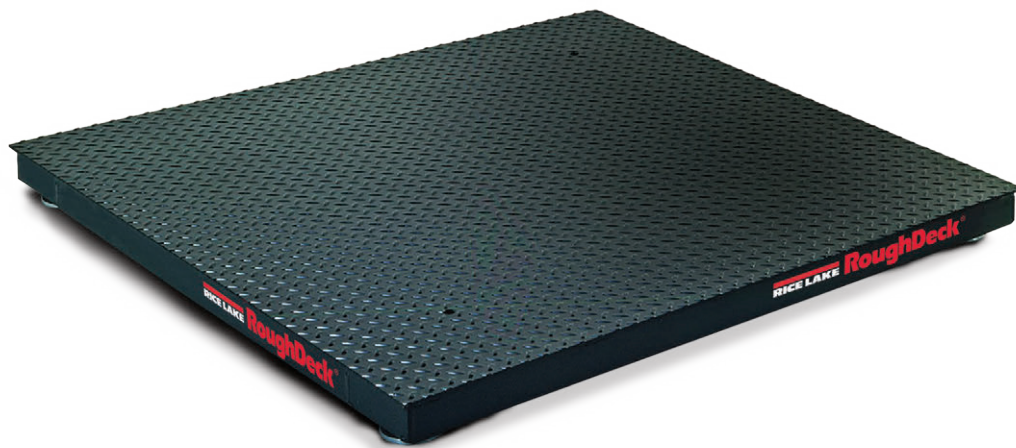

© Rice Lake Weighing Systems. All rights reserved.

Rice Lake Weighing Systems® is a registered trademark of
Rice Lake Weighing Systems.

All other brand or product names within this publication are trademarks or
registered trademarks of their respective companies.

All information contained within this publication is, to the best of our knowledge, complete and
accurate at the time of publication. Rice Lake Weighing Systems reserves the right to make
changes to the technology, features, specifications and design of the equipment without notice.

The most current version of this publication, software, firmware and all other product
updates can be found on our website:

www.ricelake.com

Revision History

This section tracks and describes manual revisions for awareness of major updates.

Revision	Date	Description
G	January 19, 2026	Established revision history; Added grounding details; Added specifications section; Updated replacement part numbers
H	April 14, 2026	Updated dimensions

Table i. Revision Letter History



Technical training seminars are available through Rice Lake Weighing Systems. Course descriptions and dates can be viewed at www.ricelake.com/training or obtained by calling 715-234-9171 and asking for the training department.

Contents

1.0 Introduction	5
1.1 Model Designations	5
1.2 Operating Requirements	5
2.0 Installation	7
2.1 Installation Overview	7
2.2 Site Preparation	7
2.3 Unpacking	7
2.4 Assembly	8
2.4.1 Installing and Adjusting Feet	8
2.4.2 Mounting Plate Installation	8
2.5 Junction Box Connections	8
2.5.1 Electrical Interface to Indicator	9
2.5.2 Electrical Grounding	9
2.6 Pit Installation	10
2.7 Access Ramps	11
3.0 Adjustments and Calibration	12
3.1 Mechanical Adjustments	12
3.2 Corner Correction	12
3.3 Calibration Procedure	12
4.0 Service Information	13
4.1 Troubleshooting Guide	13
4.2 Periodic Maintenance	13
4.3 Load Cell Replacement	13
4.3.1 Load Cell Wiring to Junction Box	15
4.4 Accessories	15
4.4.1 Pit Frames	15
4.4.2 Access Ramps	17
5.0 Specifications	18



Rice Lake continually offers web-based video training on a growing selection of product-related topics at no cost. Visit www.ricelake.com/webinars

1.0 Introduction

The RoughDeck® Floor Scales are fully electronic, low profile load receivers. The RoughDeck scales are available in sizes from 30 in x 30 in (.76 m x .76 m) to 96 in x 120 in (2.44 m x 3.05 m), and capacities from 2K- to 30K-lb (1000–15000 kg).

All models use four corner-mounted, FM-approved load cells, with the cells recessed into the frame channels for protection. Also included is a signal-trim summing board enclosed in a stainless steel, NEMA Type 4X junction box for any necessary corner corrections. All models come pre-trimmed; corner corrections should not be necessary.

Load cell cables are enclosed in conduit through the main channels, and held down with replaceable cable ties near each corner, eliminating the possibility of cable damage in portable applications. Also useful for portable applications are threaded corner holes in the deck for removable eye bolts to allow lifting the scale from above with chains. Because of the possibility of foot and load cell damage from forklift tines, the scale should always be lifted from above with chains through the eye bolts.

The adjustable feet are used to allow leveling the scale to make up for minor floor irregularities. For permanent installations, two of the four feet can be held in place on the floor with optional floor mounting plates to guard against deck movement.

Other available options include custom frames for pit installations, and access ramps for all sizes and models of the RoughDeck. Decks designed for use in pits can be ordered with holes drilled in the deck directly above each foot for adjusting foot height with a screwdriver from above. See [Section 4.4 on page 15](#) for replacement part and optional equipment part numbers.

1.1 Model Designations

The model identification label is located on the side of the frame next to the slide-out junction box. Include both model number and serial number when ordering replacement parts.



NOTE: A duplicate label is affixed inside the junction box opening.

The following model designations are used to describe the different scale versions:

HP (Rough-n-Ready)— Mild steel, high precision, NTEP-certified as “legal-for-trade” and FM-approved load cells.

HP-H — 20K- and 30K-lb capacity HP models.

HC — Similar to HP models, the HC includes overload stops at each corner of the platform. This model is approved by Measurement Canada (formerly LMB) and available for use in Canada.

1.2 Operating Requirements

The following are basic operating requirements for the RoughDeck floor scale.

Electrical Grounding

For systems where the scale is connected to a 115 VAC circuit, the indicator must be directly connected to an earth ground with a ground interface cable of no more than 3Ω resistance throughout its length.

Load Cell Excitation

Rated Excitation: 10 VDC

Maximum Excitation: 15 VDC

Grade Level Requirements

The supporting surface for the four feet of the scale must be level within 1/4 in of horizontal.

End Load Capacity

200% full scale at 1000 lb

100% full scale at 2000 lb, 5000 lb and 20,000 lb

80% full scale at 10,000 lb

66% full scale at 30,000 lb

Nominal Scale Height

2K–10K lb (1000–5000 kg) models: 3.5 in (89 mm)

20K lb (10000 kg) models: 4.0 in (102 mm)

30K lb (15000 kg) models: 5.0 in (127 mm)

Safety Definitions:



DANGER: Indicates an imminently hazardous situation that, if not avoided, will result in death or serious injury. Includes hazards that are exposed when guards are removed.



WARNING: Indicates a potentially hazardous situation that, if not avoided, could result in serious injury or death. Includes hazards that are exposed when guards are removed.



CAUTION: Indicates a potentially hazardous situation that, if not avoided, could result in minor or moderate injury.



IMPORTANT: Indicates information about procedures that, if not observed, could result in damage to equipment or corruption to and loss of data.

General Safety



Do not operate or work on this equipment unless this manual has been read and all instructions are understood. Failure to follow the instructions or heed the warnings could result in injury or death. Contact any Rice Lake Weighing Systems dealer for replacement manuals.



WARNING

Failure to heed could result in serious injury or death.

DO NOT allow minors (children) or inexperienced persons to operate this unit.

DO NOT operate without all shields and guards in place.

DO NOT jump on the scale.

DO NOT use for purposes other than weight taking.

DO NOT place fingers into slots or possible pinch points.

DO NOT use any load bearing component that is worn beyond 5% of the original dimension.

DO NOT use this product if any of the components are cracked.

DO NOT exceed the rated load limit of the unit.

DO NOT make alterations or modifications to the unit.

DO NOT remove or obscure warning labels.

DO NOT use near water.

Before opening the unit, ensure the power cord is disconnected from the outlet.

Keep hands, feet and loose clothing away from moving parts.

2.0 Installation

2.1 Installation Overview

Standard installation of the RoughDeck floor scale consists of the following steps:

1. Select a site
2. Check levelness and smoothness of site
3. Unpack scale
4. Adjust the four feet on the scale
5. Install mounting plates to the floor
6. Connect cable to junction box and indicator
7. Calibrate the unit

Pit installations and access ramps are described in [Section 2.6 on page 11](#) and [Section 2.7 on page 12](#).

2.2 Site Preparation

The scale must not be loaded beyond its capacity, even momentarily. Do not select a site where overweight loads would have to maneuver to avoid crossing the platform. Avoid areas where the scale might receive damaging side impacts from wheels or forklift tines, or shock damage from falling objects. Avoid areas where water may damage a scale not meant for a washdown environment.

The interface cable between the scale and the indicator must be protected against crushing, cutting, or moisture damage. If the chosen site has such potential dangers, some method of protection, such as running the cable in conduit, will be necessary.

In operation, the scale must be level within 1/4 inch. Either choose a site where the floor is close to this standard to avoid excessive shimming, or modify the floor at the chosen site to meet this standard.

2.3 Unpacking

Remove all packing material and inspect scale for visible damage caused during shipment.

All RoughDeck models have threaded holes in the deck to allow installation of eye bolts with shoulders for use when lifting the scale with chains or using a spreader bar.



IMPORTANT: Lift the scale only with a properly designed spreader bar as shown in [Figure 2-1](#). Lifting force must be vertical to avoid bending the eye bolts.



WARNING: Eye bolts must always be inserted into the top of the scale. Lifting should always occur with the top plate facing up and the eye bolts securely attached through the nuts welded to the bottom side of the top plate. Lifting from the bottom of the plate could cause nuts to break loose and the scale to fall.

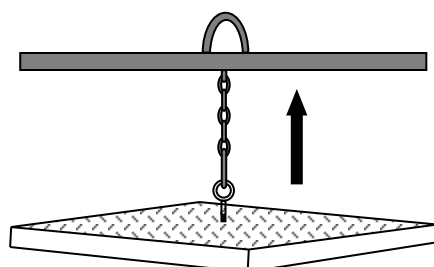

Small Platform
(5 x 5 ft or smaller and/or 10,000 lb or less capacity)
Use one 1/2 in eye bolt, insert into threaded hole in center of top plate for lifting.

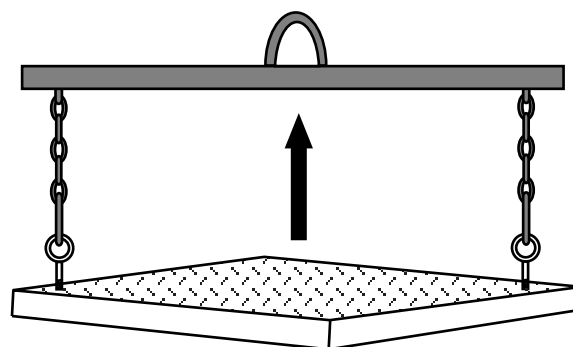

Large Platform
(Larger than 5 x 5 ft, and/or more than 10,000 lb capacity)
Use two 3/4 in eye bolts, insert into threaded holes in opposite corners of top plate for lifting.

Figure 2-1. Proper Lifting Technique

2.4 Assembly

The following paragraphs present instructions for installing and adjusting the scale feet and mounting plate installation.

2.4.1 Installing and Adjusting Feet

For load cell protection during shipping, the scale feet are shipped detached from the load cells. The feet are secured to the bottom of the shipping pallet along with the load cell cable, strain relief fitting and product literature. Remove all parts from the envelope.

Screw one foot into each load cell and turn all the way in until the foot touches either the load cell or the underside of the deck. Then unscrew each foot three complete turns.

Place a spirit level on the deck. Adjust any high corners not in contact with the floor by further unscrewing the feet on those corners until they just contact the floor surface. When all feet are in contact with the floor, check the deck with the spirit level to be sure the scale is within 1/4 in of level.

2.4.2 Mounting Plate Installation

For permanent applications, the scale should be secured to the floor to prevent sideways movement. Two mounting plates, with holes that slightly exceed the foot diameter, are available as an option for that purpose.

Lift the scale so that the feet are approximately one inch off the floor. Slide mounting plates under two diagonally opposed feet. Lower the scale back to the floor, and position the plates as shown in Figure 2-3 so that the bolt down holes are accessible from above.

Using the mounting plates as templates, drill pilot holes into the floor for suitable anchor bolts. Bolt the plates to the floor using 1/2 in anchor bolts (3/4 inch bolts for 20K and 30K-lb capacity scales). Recheck foot adjustment and deck level after this operation.

For installations using access ramps, mounting plates are not necessary as the ramps have built-in mounting plates to secure the scale feet.

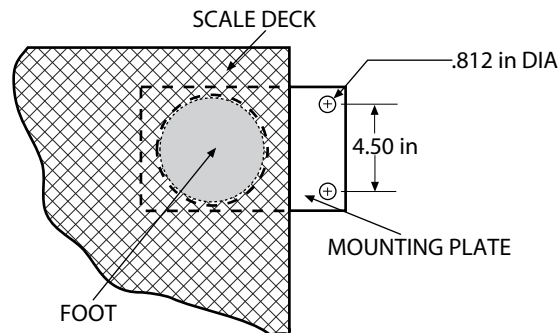

Figure 2-2. Mounting Plate Installation

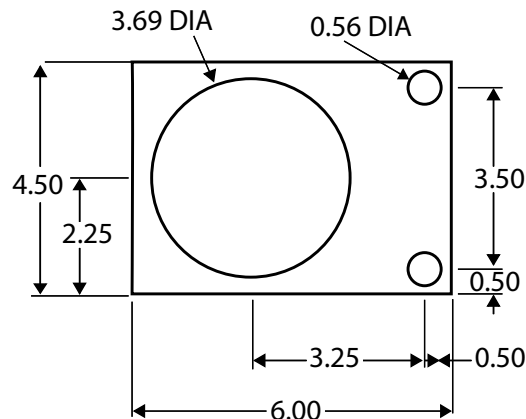

Figure 2-3. 10K Capacity Mounting Plate Dimensions (in inches)

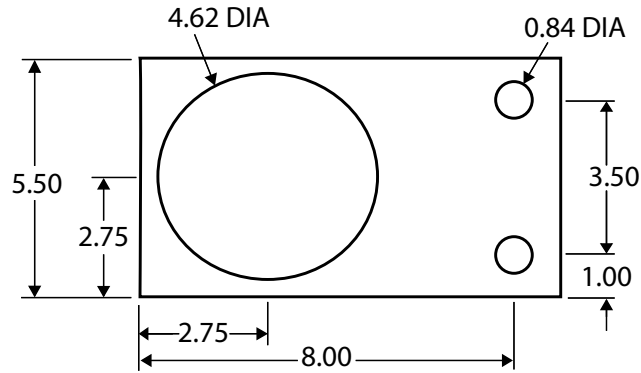

Figure 2-4. 20K Capacity Mounting Plate Dimensions (in inches)

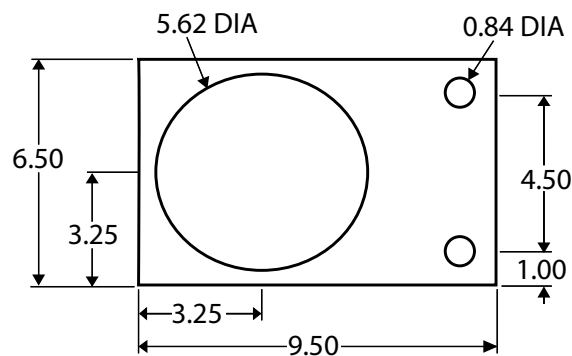

Figure 2-5. 30K Capacity Mounting Plate Dimensions (in inches)

2.5 Junction Box Connections

The indicator terminal strip is used to connect the main cable to the indicator which is shown in [Figure 2-6](#). Determine the indicator's load cell input connections from the operating manual. Run a cable from your indicator terminal into the junction box and make the connections. The following table shows the correct junction box connections using the cable color code.

Cable Color Code	Junction Box
Red	+ Excitation
Black	- Excitation
Green	+ Signal
White	- Signal
Brown	Shield
Yellow	+ Sense
Blue	- Sense

Table 2-1. Junction Box Connections

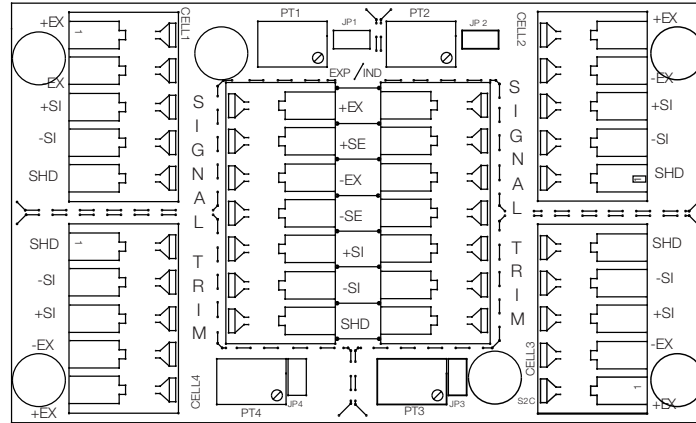

Figure 2-6. Junction Box Indicator Terminal

2.5.1 Electrical Interface to Indicator

Twenty feet of 6-wire cable to connect the scale to the weight indicator is supplied with each scale. The cable must be routed to the indicator in a manner that will protect the cable from damage. Two methods of cable protection in non-washdown applications are shown. When planning cable routing with either of these two methods, leave a loose coil of excess cable under the scale to facilitate future lifting of the scale for servicing or cleaning.

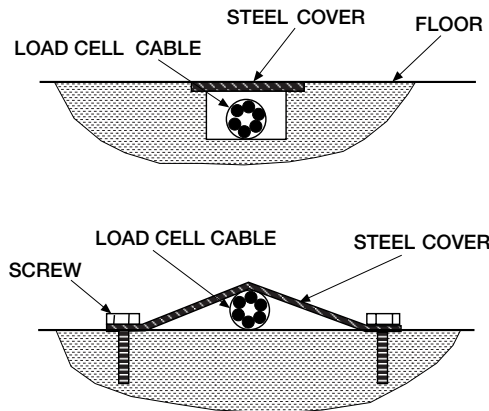

Figure 2-7. Electrical Interface to Indicator

When the interface cable is protected and in its final position, complete connections to the indicator. See indicator installation manual for wiring information. If necessary, trim corners as described in [Section 3.2 on page 12](#).

Check all strain relief fittings for tightness. Slide the junction box assembly into the cutout and secure it with the two #10 x 3/8 inch screws provided.

2.5.2 Electrical Grounding

Rolling or wheeling loads onto the scale can build up large static charges that may damage the attached indicator unless it is properly grounded to prevent ESD. This is especially true in dry environments where charges drain off slowly, or if wheeling on materials which already contain a static charge, like rolls of paper or plastic film material that have been recently spooled.

For permanent installations where the scale is connected to a 115 VAC circuit, the indicator must be directly connected to an earth ground with a ground interface cable of no more than 3 Ohms of resistance throughout its length.

For portable applications, ground by plugging the indicator into a grounded outlet, ensuring that there is no more than 3 Ohms of resistance throughout its length.



IMPORTANT: To prevent ESD damage, the indicator requires a three-prong 120 VAC outlet plug with continuous earth ground. Do not attempt to use the scale with two-prong 120 VAC power without a ground.

If using the scale with an intrinsically safe indicator, refer to FM control documents for proper grounding procedure.

2.6 Pit Installation

Any of the RoughDeck models can be installed in a shallow pit using the optional RoughDeck Pit Frame. Optional height-adjustment holes are available. The following site considerations and pit frame drawings are meant only as a brief overview of the principles involved with mounting the scale in a floor-level pit. The pit must be installed in a suitable poured-concrete foundation according to standard construction practices.

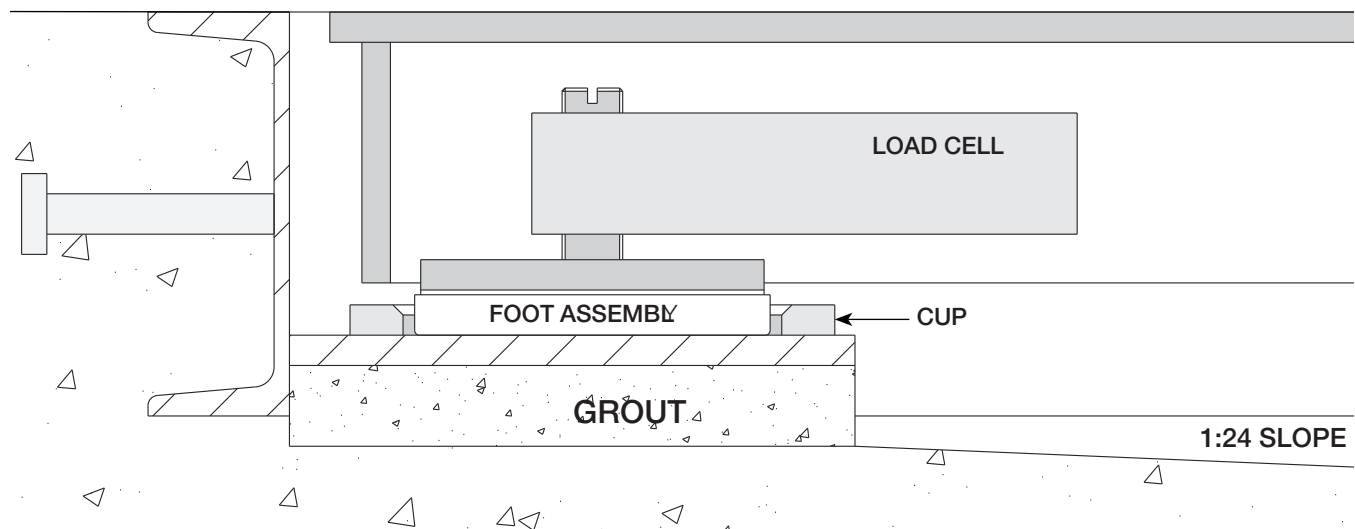
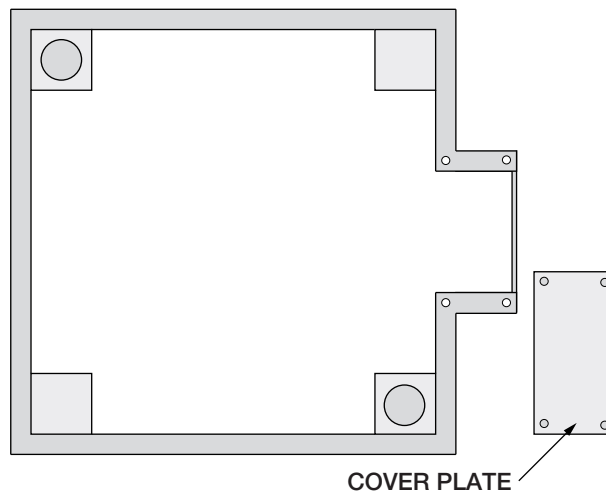

Figure 2-8. Section Showing Installed Heavy Capacity (HP-H Model) RoughDeck and Pit Frame

Site Considerations

Debris, floor sweepings, or material spills may accumulate in the pit and interfere with scale operation. You should periodically clean the pit. All RoughDeck models have threaded holes for eye bolts so the scale can be easily lifted from the pit.

Weight overloads, even momentary ones such as driving a loaded forklift over a scale corner, will damage load cells. Plan the pit location out of main traffic areas to prevent such accidental damaging overloads.

A 1:24 slope is recommended for the pit, with full grouting under the corner pads as shown in [Figure 2-7](#).



NOTE: Corner pads must be fully grouted.

2.7 Access Ramps

Access ramps for RoughDeck floor scales are designed to bolt to the floor, with built-in mounting plates that attach to the scale feet. When used with access ramps, side movement of the scale is automatically eliminated, and no other mounting plates are necessary.

Access ramps can only be attached to the scale on one of the two scale sides that are perpendicular to the longitudinal axis of the load cells. For example, the scale shown in Figure 2-9 could have an access ramp on the left side as shown, and/or on the right side. The top and bottom sides, will not accept the ramp mounting plates.

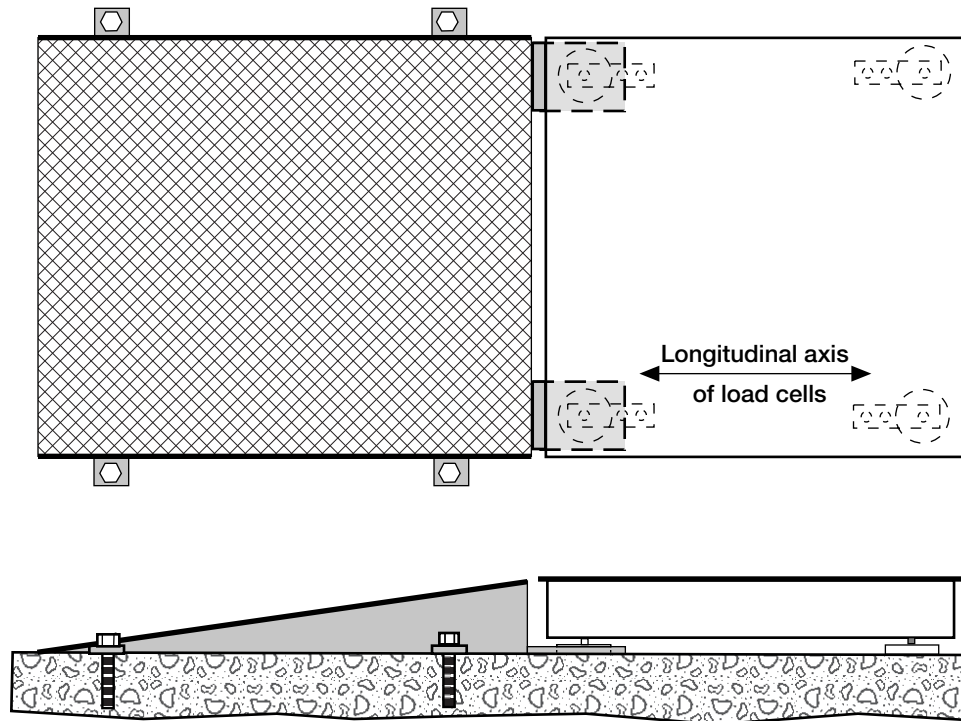

Figure 2-9. Optional Access Ramps

See [Section 4.4.2 on page 17](#) for information about available access ramps.

3.0 Adjustments and Calibration

3.1 Mechanical Adjustments

To accommodate minor floor unevenness, scale feet can be used to adjust scale height up or down a fraction of an inch. Adjust the feet by hand (lift the scale corner slightly with a pry bar) until all feet are contacting the floor equally. No jam nuts are supplied for locking the feet, as there is a slight decrease in accuracy when jam nuts are tightened. If the application requires the feet to be secured, use Teflon tape or Loctite.



CAUTION: When adjusting scale feet, use care to prevent scale foot from bottoming out against the underside of the load cell. Also, the foot stem may be damaged by bending or stripping threads if extended beyond the maximum height adjustment.

When height adjustments are complete, recheck level of the deck with a spirit level. The deck must be level within 1/4 in.

3.2 Corner Correction

All assembled RoughDeck scales are delivered with the junction box corner-trimmed. Corner trimming is only necessary after replacing a load cell.

To calibrate the scale, the output from each load cell must be matched by adjusting the signals with potentiometers at the junction box. This process is known as trimming.

Remove the junction box cover and identify the correct load cell terminal corresponding to each corner (labeled CELL 1, CELL 2, and so on). See [Figure 4-4 on page 15](#) for scale deck corner numbering.

The indicator must be connected and calibrated approximately, but it need not indicate the exact weight value. A test weight will be required. The recommended test weight for all RoughDeck models is 25% of scale capacity: for example, 500 lbs for 2K-lb models, 5000 lb for 20K-lb models.

With no weight on the scale, zero the indicator. Then turn all four potentiometers (shaded areas of

[Figure 3-1](#)) to increase the reading until a clicking sound is heard from each potentiometer. This ensures the maximum signal from each load cell.

With all potentiometers at full signal, place the test weight over one corner and record the indicated weight. Repeat the process for each of the other three corners. The load cell with the lowest corner reading will be used as a reference point and will not be trimmed.

Next, place the test weight over one of the other three corners and use that cell's potentiometer to adjust the cell output down to the reference cell output. Repeat this procedure with the other two high corners.

Adjustments are somewhat interactive, and adjusting the three higher outputs may affect the reference cell output, especially in smaller scale decks. Rezero the indicator and repeat the test until all corners read within $\pm 0.1\%$ of the test weight used.

3.3 Calibration Procedure

Refer to the indicator manual to determine correct calibration procedures.

It is recommended that the scale be "exercised" before calibration to be certain that everything is seated. Load the scale to near capacity two or three times.

Then, with no load on the scale, place the indicator in its calibration mode and perform a zero calibration. Now place test weights on the platform equal to 70% - 80% of the scale's capacity. If several weights are used, they should be evenly distributed around the platform. Perform a span calibration.

Remove the test weights and check the zero reading. Repeat the calibration process if necessary.

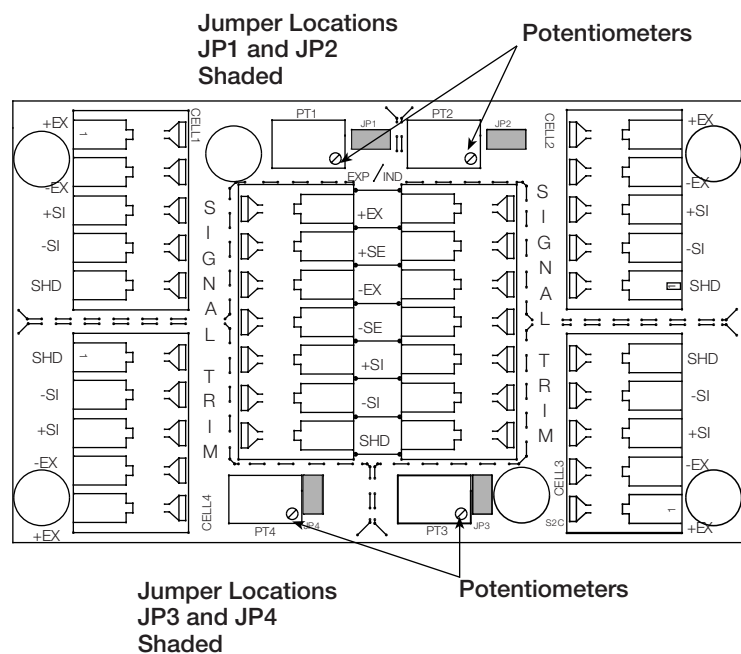

Figure 3-1. Trim Potentiometers

4.0 Service Information

4.1 Troubleshooting Guide

Issue	Possible Cause	Solution
System does not operate - no display	Power disconnected.	Check and reconnect.
	Indicator fuse blown.	Replace fuse. Check for cause.
	Interface cable cut or disconnected.	Repair.
	Signal leads incorrectly installed at indicator.	Install according to indicator installation manual
Display stays at zero	Indicator faulty.	<i>Service indicator</i>
	Load cell connections faulty.	Check cable connections in junction box and at indicator
Erratic weights	Vibration near scale.	<i>Remove source of vibration or move scale.</i>
	Platform not level to within 1/4 inch	Level scale by adjusting feet or shimming if necessary.
	Load cell or cable water damage	Replace
	Debris under load cells or platform	Clean
	Indicator faulty	Use simulator to test indicator for stability. Service indicator.
Consistently high or low weights	Indicator not properly adjusted to zero:	Zero the indicator according to indicator manual.
	Platform binding.	Obtain adequate clearance for free platform movement.
	Indicator not calibrated.	Calibrate according to indicator manual and Section 3.3 on page 12
	Load cells faulty.	Test and replace load cells if necessary.
	Feet touching deck underside.	Adjust feet downward to provide clearance.

Table 4-1. Troubleshooting

4.2 Periodic Maintenance

The space between the platform side and pit frame, and the surface beneath the platform must be periodically cleaned to prevent debris build up. More frequent cleaning of these areas is necessary with scales mounted in pits.



CAUTION: Do not attempt to use scales with load cells that are not hermetically sealed in washdown applications. Water damage is a common cause of failure in non-hermetically-sealed load cells. Use care with high pressure steam wash downs for hermetically-sealed load cells. The steam may not damage the load cells, but the elevated temperatures may cause incorrect readings until the unit cools to room temperature.

4.3 Load Cell Replacement

Lift scale with chains and proper spreader bar and remove foot, then remove defective load cell. Disconnect load cell cable from junction box and cut cable ties. When the cable is freed, pull cable out of the scale frame channels.

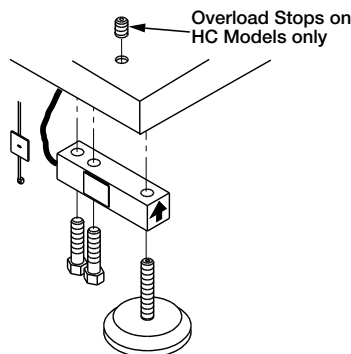

Figure 4-1. Load Cell Assembly

Follow the directions given below to install new load cells.

For Canadian HC models, overload stops should be loosened two full turns before installing new load cells. To reset overload stops after load cell installation, place a weight equal to 25% of the load cell capacity on the affected scale corner. Screw in the overload stop until the indicator reading changes. Then back off the overload stop 1/6 turn. Repeat for each corner where the load cell has been changed.

Lay out the four load cells near the corners where they are to be installed. Thread the cable from each load cell through the conduit tubing in the frame and into the junction box according to the wiring diagram in [Figure 4-2](#).

Note that in [Figure 4-2](#) both the scale and the junction box are viewed from the bottom. To verify correct load cell/junction box terminal matching, see the numbers on the terminals inside the junction box and the corner numbering diagram in [Figure 4-4](#).

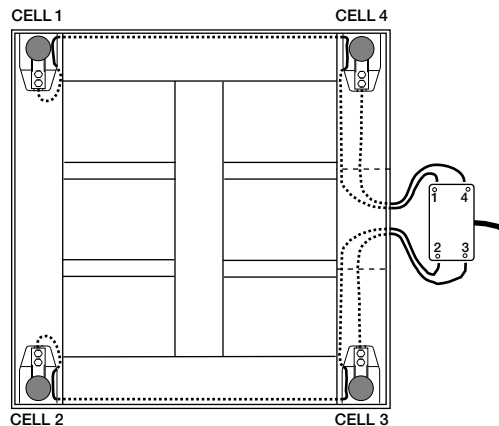

Figure 4-2. Bottom View of Scale

Check that the threaded holes for the load cell screws are free of debris. Use compressed air to blow out holes if necessary. Position load cells with alignment arrows point up toward the deck and loosely install the hex head cap screws provided, as shown in [Figure 4-1](#). If the base is used with a pit frame or access ramp, position the load cell to maintain the dimension shown in [Figure 4-3](#). With the torque wrench, tighten all bolts as follows (outboard bolts first):

- 2K–10K-lb capacities: Torque to 75 ft-lbs.
- 20K-lb and 30K-lb capacities: Torque to 250ft-lbs.

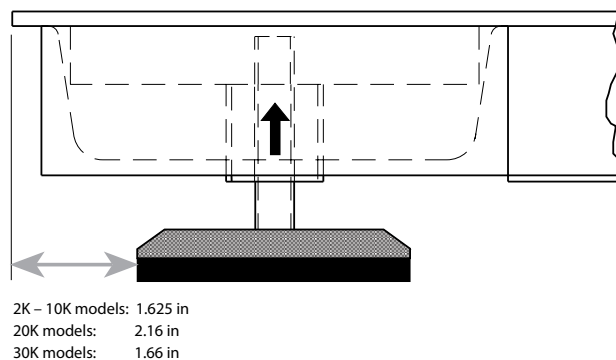

Figure 4-3. Foot Pad - Side View

Route the load cell cables near each corner so that the cable is free from possible contact with each foot. Hold the cable in position with the adhesive-backed cable ties supplied in the hardware kit.

Do not cut load cell cables. Coil extra cable before it enters the junction box, tie with cable ties, and insert the coils into the channel.

After coiling excess cable, pass each individual end of load cell cable through its cord grip in the NEMA Type 4X junction box.

Corner correction trimming and calibration is necessary after load cell replacement. Follow instruction in [Section 3.2 on page 12](#) and [Section 3.3 on page 12](#).

4.3.1 Load Cell Wiring to Junction Box

The four load cells are each wired to their respective terminals in the junction box according to the corner numbering system shown in Figure 4-4, and the coloring code in Table 4-2.

Pull excess cable out of the junction box enclosure and tighten the cord grip dome nuts with a wrench. To be watertight, the nuts must be tightened to the point where the rubber sleeving begins to protrude out of the nut. Finally, pull on each of the four cables to make sure that they do not slip.

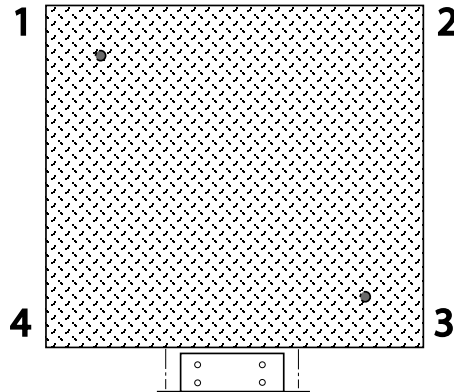

Figure 4-4. Corner Numbering - Top View

Color Cable Code	J-Box Terminal
Red	+ Excitation
Black	- Excitation
Green	+ Signal
White	- Signal
Bare or Clear	Shield

Table 4-2. Load Cell Wiring

4.4 Accessories

The following tables list the pit frames and access ramps for HP, HC, and HP-H model RoughDeck floor scales.

4.4.1 Pit Frames

PN with Junction Box Pocket	PN without Junction Box Pocket	Imperial		Metric	
		Width	Length	Width	Length
18757	224271	2.5 ft	2.5 ft	0.76 m	0.76 m
18759	224272	3 ft	3 ft	0.91 m	0.91 m
18761	224273	4 ft	4 ft	1.22 m	1.22 m
18763	224274	5 ft	5 ft	1.52 m	1.52 m
18765	224275	4 ft	5 ft	1.22 m	1.52 m
18767	224276	4 ft	6 ft	1.22 m	1.83 m
18769	224277	5 ft	6 ft	1.52 m	1.83 m
18771	224278	5 ft	7 ft	1.52 m	2.13 m

Table 4-3. RoughDeck HP and HC Pit Frames: 1,000 to 10,000 lb

PN with Junction Box Pocket	PN without Junction Box Pocket	Imperial		Metric	
		Width	Length	Width	Length
39595	224279	4 ft	4 ft	1.22 m	1.22 m
39596	224280	4 ft	5 ft	1.22 m	1.52 m
39597	224281	4 ft	6 ft	1.22 m	1.83 m
39598	224282	4 ft	7 ft	1.22 m	2.13 m
39599	224283	5 ft	5 ft	1.52 m	1.52 m
39600	224284	5 ft	6 ft	1.52 m	1.83 m
39601	224285	5 ft	7 ft	1.52 m	2.13 m
39602	224286	6 ft	6 ft	1.83 m	1.83 m
39603	224287	6 ft	7 ft	1.83 m	2.13 m
39604	224288	6 ft	8 ft	1.83 m	2.44 m
39605	224289	7 ft	9 ft	2.13 m	2.74 m
39606	224290	7 ft	10 ft	2.13 m	3.04 m
39607	224291	8 ft	10 ft	2.44 m	3.04 m

Table 4-4. RoughDeck HP-H Pit Frames: 20,000 lb

PN with Junction Box Pocket	PN without Junction Box Pocket	Imperial		Metric	
		Width	Length	Width	Length
39608	224292	4 ft	4 ft	1.22 m	1.22 m
39609	224293	4 ft	5 ft	1.22 m	1.52 m
39610	224294	4 ft	6 ft	1.22 m	1.83 m
39611	224295	4 ft	7 ft	1.22 m	2.13 m
39612	224296	5 ft	5 ft	1.52 m	1.52 m
39613	224297	5 ft	6 ft	1.52 m	1.83 m
39614	224298	5 ft	7 ft	1.52 m	2.13 m
39615	224299	6 ft	6 ft	1.83 m	1.83 m
39619	224300	7 ft	10 ft	2.13 m	2.13 m
39620	224301	8 ft	10 ft	2.44 m	3.04 m

Table 4-5. RoughDeck HP-H Pit Frames: 30,000 lb

4.4.2 Access Ramps

PN with Side Rails	PN without Side Rails	Imperial			Metric		
		Width	Length	Height	Width	Length	Height
69040	224097	2.5 ft	3 ft	3.5 in	0.76 m	0.91 m	89 mm
69041	224099	3 ft	3 ft	3.5 in	0.91 m	0.91 m	89 mm
69042	224100	4 ft	3 ft	3.5 in	1.22 m	0.91 m	89 mm
69043	224101	5 ft	3 ft	3.5 in	1.52 m	0.91 m	89 mm
69184	224102	2.5 ft	4 ft	3.5 in	0.76 m	1.22 m	89 mm
69185	224103	3 ft	4 ft	3.5 in	0.91 m	1.22 m	89 mm
69186	224104	4 ft	4 ft	3.5 in	1.22 m	1.22 m	89 mm
69187	224105	5 ft	4 ft	3.5 in	1.52 m	1.22 m	89 mm

Table 4-6. RoughDeck HP and HC Access Ramps: 1,000 to 10,000 lb

PN with Side Rails	PN without Side Rails	Imperial			Metric		
		Width	Length	Height	Width	Length	Height
69204	224106	4 ft	4 ft	4 in	1.22 m	1.22 m	101.6 mm
69205	224107	5 ft	4 ft	4 in	1.52 m	1.22 m	101.6 mm
69206	224108	6 ft	4 ft	4 in	1.83 m	1.22 m	101.6 mm
69207	224109	7 ft	4 ft	4 in	2.13 m	1.22 m	101.6 mm
69208	224110	8 ft	4 ft	4 in	2.44 m	1.22 m	101.6 mm

Table 4-7. RoughDeck HP-H Access Ramps: 20,000 lb

PN with Side Rails	PN without Side Rails	Imperial			Metric		
		Width	Length	Height	Width	Length	Height
69210	224111	4 ft	5 ft	5 in	1.22 m	1.52 m	127 mm
69211	224112	5 ft	5 ft	5 in	1.52 m	1.52 m	127 mm
69212	224113	6 ft	5 ft	5 in	1.83 m	1.52 m	127 mm
69213	224114	7 ft	5 ft	5 in	2.13 m	1.52 m	127 mm
69214	224115	8 ft	5 ft	5 in	2.44 m	1.52 m	127 mm

Table 4-8. RoughDeck HP-H Access Ramps: 30,000 lb

5.0 Specifications

End Load Capacity:

200% full scale at 1,000 lb
100% full scale at 2,000 and 5,000 lb
80% full scale at 10,000 lb

Cable Length:

20 ft (6.1 m) for connecting junction box to indicator

Junction Box:

TuffSeal® JB4SS stainless steel, NEMA Type 4X
junction box with signal trim card

Welding:

Stitch

Threaded Eyebolt:

Hole (1/2-20 NF) located in center of deck for
easy lifting

Warranty (limited):

Weldment: Five years
Load cells: Two years
All other components: One year

Approvals:**NTEP**

92-001, Class III 5,000 d

**Measurement Canada**

AM-4827, Class III 5,000d





© Rice Lake Weighing Systems Content subject to change without notice.

230 W. Coleman St. • Rice Lake, WI 54868 • USA USA: 800-472-6703 • International: +1-715-234-9171