

Health Scales

TABLE OF CONTENTS

Health Scales	453	250-10-4	474
RL-330HHD	454	<i>Bariatric Handrail Scale</i>	
<i>Dial Home Health Scale</i>		RL-MCS	475
DHH-10	455	<i>Mechanical Chair Scale</i>	
<i>Digital Home Health Scale</i>		560-10-1	476
RL-MPS	456	<i>Digital Chair Scale</i>	
<i>Mechanical Physician Scale</i>		550-10-1	477
RL-MPS-10	457	<i>Digital Chair Scale</i>	
<i>Mechanical Physician Scale</i>		350-ADA-1	478
RL-MPS-30	458	<i>Dual-ramp ADA Compliant Wheelchair Scale</i>	
<i>Mechanical Physician Scale</i>		350-10-3M	479
RL-MPS-40	459	<i>Dual-ramp Wheelchair Scale</i>	
<i>Mechanical Physician Scale</i>		350-10-2	480
RL-MPS-50	460	<i>Single-ramp Wheelchair Scale</i>	
<i>Mechanical Physician Scale</i>		350-10-7	481
150-10-5	461	<i>Single-ramp Wheelchair Platform Scale</i>	
<i>Digital Physician Scale</i>		350-10-3	482
150-10-6	462	<i>Dual-ramp Wheelchair Scale</i>	
<i>Digital Physician Scale</i>		350-10-4	483
150-10-7	463	<i>Dual-ramp Wheelchair Scale</i>	
<i>Digital Physician Scale</i>		350-10-8	484
150-10-8	464	<i>Dual-ramp Wheelchair Platform Scale</i>	
<i>Digital Physician Scale</i>		RL-350-5	485
160-10-7N	465	<i>Single-ramp Portable Bariatric Wheelchair Scale</i>	
<i>Digital Athletic Low-profile Scale</i>		RL-350-6	486
RL-WMS-10	466	<i>Dual-ramp Portable Bariatric Wheelchair Scale</i>	
<i>Wall Mount Stadiometer</i>		SB-1150 Summit™	487
RL-MIS	467	<i>Bariatric Wheelchair Scale</i>	
<i>Mechanical Baby Scale</i>		SD-1150-WP	488
RL-MIS-20	468	<i>Dialysis Wheelchair Scale</i>	
<i>Mechanical Baby Scale</i>		<i>Pit Frame Concrete Details</i>	
RL-DBS	469	350-10-8S	490
<i>Digital Baby Scale</i>		<i>Digital Stretcher Scale</i>	
RL-DBS-2	470		
<i>Digital Baby Scale</i>			
650-10-1	471		
<i>Neonatal Scale</i>			
260-10-1	472		
<i>Bariatric Handrail Scale</i>			
250-10-2	473		
<i>Bariatric Handrail Scale</i>			

Product names, logos, brands and other trademarks featured or referred to within this publication are the property of their respective trademark holders.

RL-330HHD

Dial Home Health Scale

HEALTH SCALES



Standard Features

- Durable steel base and platform
- Non-slip mat
- Large dial display
- Colorful markers to track weight values

Specifications

Capacity:
330 × 1 lb (150 × 0.5 kg)

Warranty:
One-year limited

Part Number/Price

Part #	Model #	Capacity	Price
113500	RL-330HHD	330 × 1 lb (150 × 0.5 kg) (lb and kg)	\$72.00

Shipping Weight

Part #	Model #	L × W × H	Package Wgt. (lb)	Dim Wgt. (lb)	Shipping Wgt. (lb)
113500	RL-330HHD	19 × 12 × 5 in	9	9	9

Dimensions

	Inches	Centimeters
A	11.20	28.5
B	16.90	43.0
C	2.50	6.4
D	7.90	20.1
E	0.39	8.3

E: (height includes plastic cover)

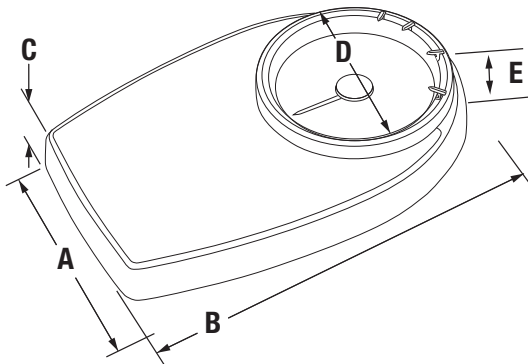

DHH-10

Digital Home Health Scale

HEALTH SCALES



Standard Features

- Large LCD display
- Display lb or kg
- 8 mm tempered safety glass weighing surface
- Low battery indication

Specifications

- Capacity:**
440 × 0.2 lb (200 × 0.1 kg)
- Dimensions:**
(L × W × H)
11.8 × 15.4 × 1.0 in
- Battery Type:**
Two AAA alkaline batteries (included)
- Display:**
Digit size: 1.75 in
- Warranty:**
One-year limited
- Approvals:**
CE Approved

Approvals



Part Number/Price

Part #	Model #	Capacity	Price
201124	DHH-10	440 × 0.2 lb (200 × 0.1 kg)	\$72.00

Shipping Weight

Part #	Model #	L × W × H	Package Wgt. (lb)	Dim Wgt. (lb)	Shipping Wgt. (lb)
Single Carton					
201124	DHH-10	17 × 13 × 2 in	6.5	3.0	6.5

Dimensions

	Inches	Centimeters
A	15.40	39.0
B	11.80	30.0
C	1.00	2.5

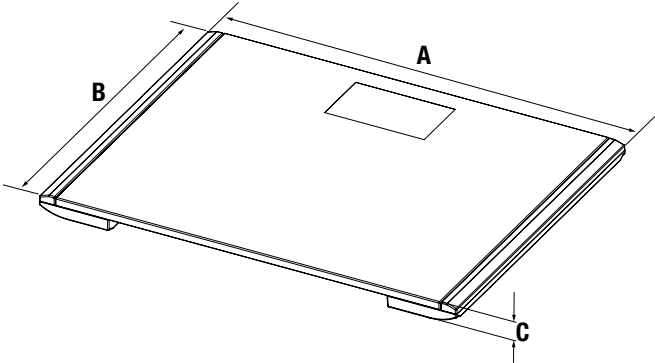

RL-MPS

Mechanical Physician Scale

HEALTH SCALES



Standard Features

- Sturdy, enameled steel body
- Painted beam
- Rugged scale understructure
- Two wheels for easy transport
- Simple operation with two sliding weights
- Removable, slip-resistant scale base cover
- Aluminum height rod

Specifications

Capacity:

440 lb × 4 oz (200 kg × 100 g)

Platform Dimensions:

(L × W × H)

14.75 × 10.75 × 4.13 in

Height Rod:

Measures 24 to 84 in
(60 to 212 cm)

Height Division:

0.125 in (0.1 cm)

Warranty:

Two-year limited

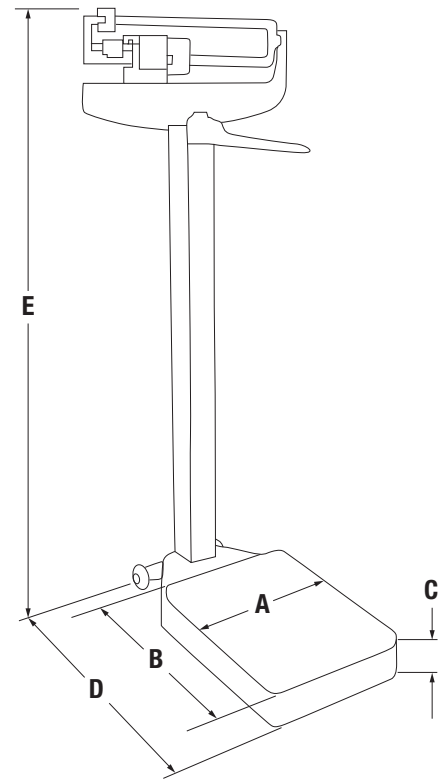

Dimensions

	Inches	Centimeters
A	10.75	27.3
B	14.75	37.5
C	4.13	10.5
D	22.30	56.6
E	58.50	148.6

Part Number/Price

Part #	Model #	Capacity	Price
102613	RL-MPS	440 lb × 4 oz (200 kg × 100 g)	\$380.00

Shipping Weight

Part #	Model #	L × W × H	Package Wgt. (lb)	Dim Wgt. (lb)	Shipping Wgt. (lb)
102613	RL-MPS	60 × 21 × 7 in	42	64	64

RL-MPS-10

Mechanical Physician Scale

HEALTH SCALES



LB Only

Standard Features

- Sturdy, enameled steel body
- Painted beam
- Rugged scale understructure
- Durable wheels for easy transport
- Simple operation with two sliding weights
- Removable, slip-resistant scale base cover
- Aluminum height rod

Specifications

Capacity:

450 lb × 4 oz

Platform Dimensions:

(L × W × H)

14.75 × 10.75 × 4.13 in

Height Rod:

Measures 24 to 84 in

Height Division:

0.125 in

Warranty:

Two-year limited

Part Number/Price

Part #	Model #	Capacity	Price
124223	RL-MPS-10	450 lb × 4 oz	\$345.00

Shipping Weight

Part #	Model #	L × W × H	Package Wgt. (lb)	Dim Wgt. (lb)	Shipping Wgt. (lb)
124223	RL-MPS-10	60 × 21 × 7 in	42	64	64

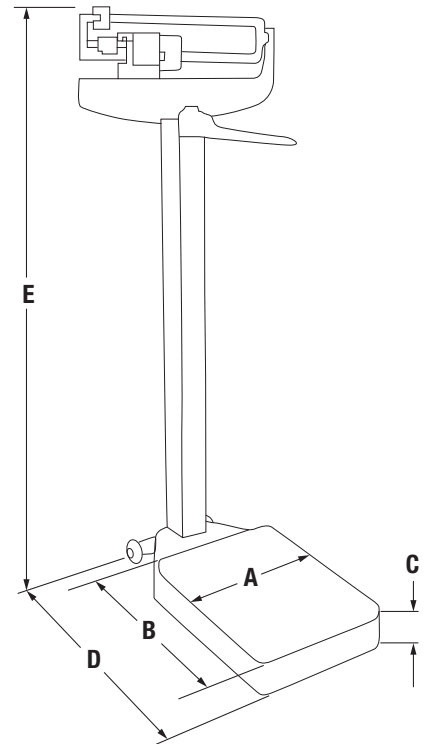

Dimensions

	Inches	Centimeters
A	10.75	27.3
B	14.75	37.5
C	4.13	10.5
D	22.30	56.6
E	58.50	148.6

RL-MPS-30

Mechanical Physician Scale

HEALTH SCALES



Standard Features

- Sturdy, enameled steel body
- Painted beam
- Rugged scale understructure
- Hand post
- Two wheels for easy transport
- Simple operation with two sliding weights
- Removable, slip-resistant scale base cover
- Aluminum height rod

Specifications

Capacity:

180 kg x 100 g

Platform Dimensions:

(L x W x H)
37.5 x 27.3 x 10.5 cm

Height Rod:

Measures 60 to 212 cm

Height Division:

0.1 cm

Warranty:

Two-year limited

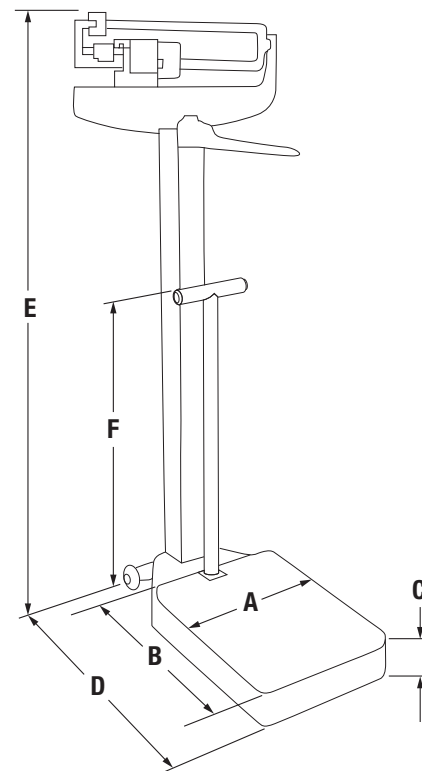

Part Number/Price

Part #	Model #	Capacity	Price
132703	RL-MPS-30	180 kg x 100 g	\$385.00

Shipping Weight

Part #	Model #	L x W x H	Package Wgt. (lb)	Dim Wgt. (lb)	Shipping Wgt. (lb)
132703	RL-MPS-30	60 x 21 x 7 in	40	64	64

Dimensions

	Inches	Centimeters
A	10.75	27.3
B	14.75	37.5
C	4.13	10.5
D	22.30	56.6
E	58.50	148.6
F	31.50	80.0

RL-MPS-40

Mechanical Physician Scale

HEALTH SCALES



Standard Features

- Dual-read capacity and height rod
- Sturdy enameled steel body
- Painted beam designed to hold counterpoise weights
- Rugged scale understructure
- Removable, slip-resistant plastic scale base cover
- Retractable aluminum height rod
- Simple operation with two sliding weights and two counterpoise weights (included)
- Two wheels for easy transport
- Aluminum height rod

Specifications

Capacity:

490 lb × 4 oz (220 kg × 100 g)

Platform Dimensions:

(L × W × H)
14.75 × 10.75 × 4.13 in

Height Rod:

Measures 24 to 84 in
(60 to 212 cm)

Height Division:

0.125 in (0.1 cm)

Warranty:

Two-year limited

Part Number/Price

Part #	Model #	Capacity	Price
185289	RL-MPS-40	490 lb × 4 oz (220 kg × 100 g)	\$375.00

Shipping Weight

Part #	Model #	L × W × H	Package Wgt. (lb)	Dim Wgt. (lb)	Shipping Wgt. (lb)
185289	RL-MPS-40	60 × 21 × 7 in	44	64	64

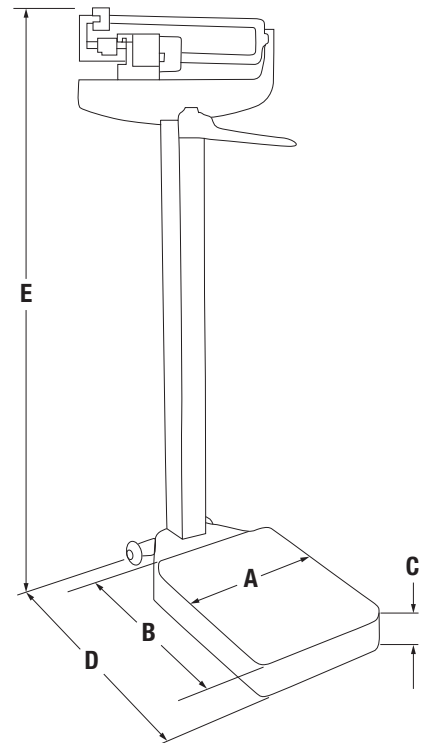

Dimensions

	Inches	Centimeters
A	10.75	27.3
B	14.75	37.5
C	4.13	10.5
D	22.30	56.6
E	58.50	148.6

RL-MPS-50

Mechanical Physician Scale

HEALTH SCALES



Standard Features

- Two wheels for easy transport
- Aluminum height rod included
- Poise travels free on weigh beam with simple finger tap
- Easy-to-read weigh beam
- Color-coded black inset shows lb markings and white inset shows kg markings
- The beam can be rotated to the desired unit of measure
- Aluminum height rod

Specifications

Capacity:

450 lb × 4 oz (200 kg × 100 g)

Platform Dimensions:

(L × W × H)

14.75 × 10.75 × 4.13 in

Height Rod:

Measures 29.50 to 78.75 in

(75 to 200 cm)

Height Division:

0.25 in (5 mm)

Warranty:

Two-year limited

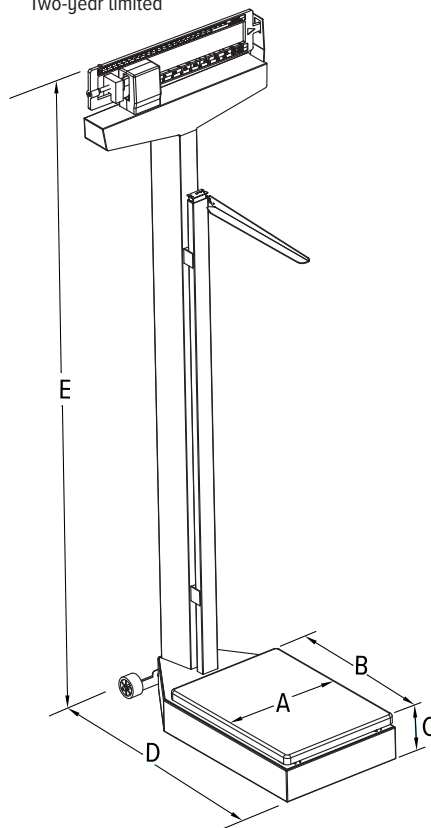

Part Number/Price

Part #	Model #	Capacity	Price
195264	RL-MPS-50	450 lb × 4 oz (200 kg × 100 g)	\$380.00

Shipping Weight

Part #	Model #	L × W × H	Package Wgt. (lb)	Dim Wgt. (lb)	Shipping Wgt. (lb)
195264	RL-MPS-50	60 × 21 × 5 in	39	46	46



Dimensions

	Inches	Centimeters
A	10.75	27.3
B	14.75	37.5
C	4.13	10.5
D	22.30	56.6
E	58.50	148.6



Standard Features

- Large push-button LCD display
- Antimicrobial keypad
- Large, stable scale base
- Integrated height rod
- Nonslip rubber mat, removable for cleaning
- Two wheels for easy transport
- Unit of measure toggle or locking
- Motiontrap™ movement compensation technology
- EMR capable
- Serial and USB data communication ports
- Wireless personal area network (WPAN) option available
- Hold function
- Zero function
- Body mass index (BMI) function
- Factory calibrated

Specifications

Capacity:

550 × 0.2 lb (250 × 0.1 kg)

Platform Dimensions:

(L × W × H)
14.70 × 14.70 × 3.00 in

Height Rod:

Measures from 27.50 to 82.00 in
(70 to 208 cm)

Power:

9 VDC, provided by six AA alkaline batteries (included) or AC adapter (optional)

Battery Type:

Six AA alkaline (included)

Battery Use:

25 hours continuous use with batteries
Automatic power-off can be configured

Display:

Five-digit LCD display,
0.75 in (1.9 cm) digit height

Temperature:

Operating:
50 °F to 104 °F (10 °C to 40 °C)

Warranty:

Two-year limited

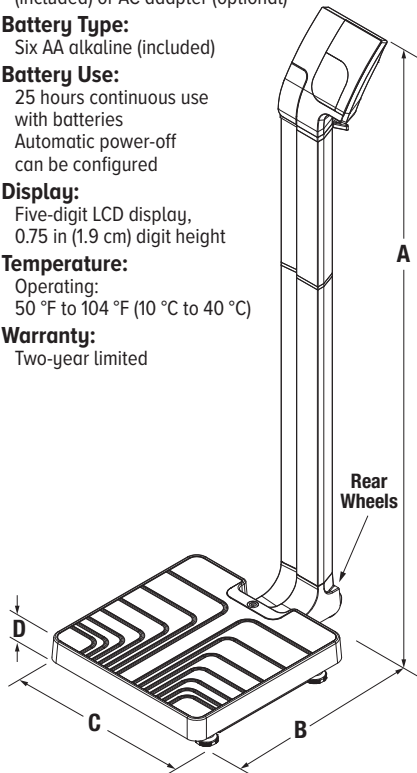

Part Number/Price

Part #	Model #	Capacity	Price
119113	150-10-5	550 × 0.2 lb (250 × 0.1 kg) with USB	\$695.00
194726	150-10-5WPAN	550 × 0.2 lb (250 × 0.1 kg) WPAN	\$930.00

Shipping Weight

Part #	Model #	L × W × H	Package Wgt. (lb)	Dim Wgt. (lb)	Shipping Wgt. (lb)
119113	150-10-5	30 × 18 × 9 in	26	35	35
194726	150-10-5WPAN	30 × 18 × 9 in	26	35	35

Options/Accessories

Part #	Description	Price
115655 †	9VDC adapter, 100-240V, NEMA 1-15 Plug, medical grade power supply	\$43.00
133077 †	9VDC adapter, 100-240V, NEMA 1-15 Plug, cULus power supply	\$30.00
102508 ††	9VDC adapter, 100-240V, CEE 7/16 Plug, medical grade power supply	\$30.00



† NEMA 1-15 Plug

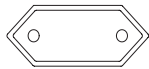

†† CEE 7/16 Plug

Dimensions

	Inches	Centimeters
A	54.00	137.2
B	22.40	56.9
C	14.70	37.5
D	3.00	7.6

150-10-6

Digital Physician Scale

HEALTH SCALES



WAIST-LEVEL

Standard Features

- Large push-button LCD display
- Antimicrobial keypad
- Large, stable scale base
- Two wheels for easy transport
- Nonslip rubber mat, removable for cleaning
- Unit of measure toggle or locking
- Motiontrap™ movement compensation technology
- EMR capable
- Serial and USB data communication ports
- Wireless personal area network (WPAN) option available
- Hold function
- Zero function
- Body mass index (BMI) function
- Factory calibrated

Specifications

Capacity:

550 × 0.2 lb (250 × 0.1 kg)

Platform Dimensions:

(L × W × H)
14.70 × 14.70 × 3.00 in

Power:

9 VDC, provided by six AA alkaline batteries (included) or AC adapter (optional)

Battery Type:

Six AA alkaline (included)

Battery Use:

25 hours continuous use with batteries
Automatic power-off can be configured

Display:

Five-digit LCD display,
0.75 in (1.9 cm) digit height

Temperature:

Operating:
50 °F to 104 °F (10 °C to 40 °C)

Warranty:

Two-year limited

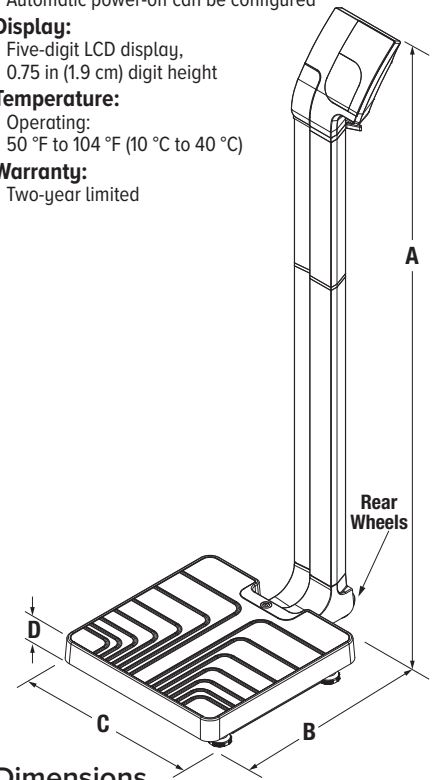

Dimensions

	Inches	Centimeters
A	48.40	123.0
B	22.40	56.9
C	14.70	37.5
D	3.00	7.6

Part Number/Price

Part #	Model #	Capacity	Price
161786	150-10-6	550 × 0.2 lb (250 × 0.1 kg) with USB	\$675.00
194732	150-10-6WPAN	550 × 0.2 lb (250 × 0.1 kg) WPAN	\$910.00

Shipping Weight

Part #	Model #	L × W × H	Package Wgt. (lb)	Dim Wgt. (lb)	Shipping Wgt. (lb)
161786	150-10-6	30 × 19 × 9 in	25	37	37
194732	150-10-6WPAN	30 × 19 × 9 in	25	37	37

Options/Accessories

Part #	Description	Price
115655 †	9VDC adapter, 100-240V, NEMA 1-15 Plug, medical grade power supply	\$43.00
133077 †	9VDC adapter, 100-240V, NEMA 1-15 Plug, cULus power supply	\$30.00
102508 ††	9VDC adapter, 100-240V, CEE 7/16 Plug, medical grade power supply	\$30.00



† NEMA 1-15 Plug

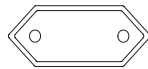

†† CEE 7/16 Plug



Standard Features

- Large push-button LCD display
- Antimicrobial keypad
- Large, stable scale base
- Nonslip rubber mat, removable for cleaning
- Unit of measure toggle or locking
- Motiontrap™ movement compensation technology
- EMR capable
- Serial and USB data communication port
- Wireless personal area network (WPAN) option available
- Hold function
- Zero function
- Body mass index (BMI) function
- Factory calibrated

Specifications

Capacity:

550 × 0.2 lb (250 × 0.1 kg)

Platform Dimensions:

(L × W × H)

14.70 × 14.70 × 3.00 in

Power:

9 VDC, provided by six AA alkaline batteries (included) or AC adapter (optional)

Battery Type:

Six AA alkaline (included)

Battery Use:

25 hours continuous use with batteries
Automatic power-off can be configured

Display:

Five-digit LCD display, 0.75 in (1.9 cm) digit height

Cable Length:

6 ft (1.8 m) cable between scale base and indicator

Temperature:

Operating:
50 °F to 104 °F (10 °C to 40 °C)

Warranty:

Two-year limited

Part Number/Price

Part #	Model #	Capacity	Price
121304	150-10-7	550 × 0.2 lb (250 × 0.1 kg) with USB	\$555.00
194728	150-10-7WPAN	550 × 0.2 lb (250 × 0.1 kg) WPAN	\$790.00

Shipping Weight

Part #	Model #	L × W × H	Package Wgt. (lb)	Dim Wgt. (lb)	Shipping Wgt. (lb)
121304	150-10-7	25 × 18 × 6 in	17	20	20
194728	150-10-7WPAN	25 × 18 × 6 in	17	20	20

Options/Accessories

Part #	Description	Price
115655 †	9VDC adapter, 100-240V, NEMA 1-15 Plug, medical grade power supply	\$43.00
102508 ††	9VDC adapter, 100-240V, CEE 7/16 Plug, medical grade power supply	\$30.00
133077 †	9VDC adapter, 100-240V, NEMA 1-15 Plug, cULus power supply	\$30.00
107445	Carrying case	\$92.00



† NEMA 1-15 Plug

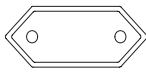

†† CEE 7/16 Plug

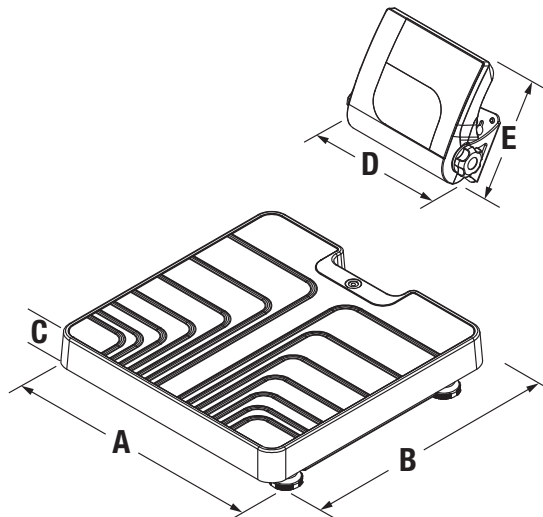

Dimensions

	Inches	Centimeters
A	14.70	37.5
B	14.70	37.5
C	3.00	7.6
D	7.80	19.8
E	6.70	17.0

150-10-8

Digital Physician Scale

HEALTH SCALES



FLOOR LEVEL WITH ATTACHED INDICATOR

Standard Features

- Large push-button LCD display
- Antimicrobial keypad
- Large, stable scale base
- Nonslip rubber mat, removable for cleaning
- Unit of measure toggle or locking
- Motiontrap™ movement compensation technology
- EMR capable
- USB and Wireless personal area network (WPAN) option available
- Hold function
- Zero function
- Body mass index (BMI) function
- Factory calibrated

Specifications

Capacity:

550 × 0.2 lb (250 × 0.1 kg)

Platform Dimensions:

(L × W × H)

14.70 × 14.70 × 3.00 in

Power:

9 VDC, provided by six AA alkaline batteries (included) or AC adapter (optional)

Battery Type:

Six AA alkaline (included)

Battery Use:

25 hours continuous use with batteries
Automatic power-off can be configured

Display:

Five-digit LCD display, 0.75 in (1.9 cm) digit height

Temperature:

Operating:
50 °F to 104 °F (10 °C to 40 °C)

Warranty:

Two-year limited

Part Number/Price

Part #	Model #	Capacity	Price
224055	150-10-8	550 × 0.2 lb (250 × 0.1 kg) with USB	\$575.00
224056	150-10-8WPAN	550 × 0.2 lb (250 × 0.1 kg) WPAN	\$810.00

Shipping Weight

Part #	Model #	L × W × H	Package Wgt. (lb)	Dim Wgt. (lb)	Shipping Wgt. (lb)
224055	150-10-8	12.7 × 22.4 × 14.7 in	25	37	37
224056	150-10-8WPAN	12.7 × 22.4 × 14.7 in	25	37	37

Options/Accessories

Part #	Description	Price
115655 †	9VDC adapter, 100-240V, NEMA 1-15 Plug, medical grade power supply	\$43.00
133077 †	9VDC adapter, 100-240V, NEMA 1-15 Plug, cULus power supply	\$30.00
102508 ††	9VDC adapter, 100-240V, CEE 7/16 Plug, medical grade power supply	\$30.00



† NEMA 1-15 Plug

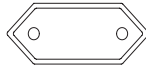

†† CEE 7/16 Plug

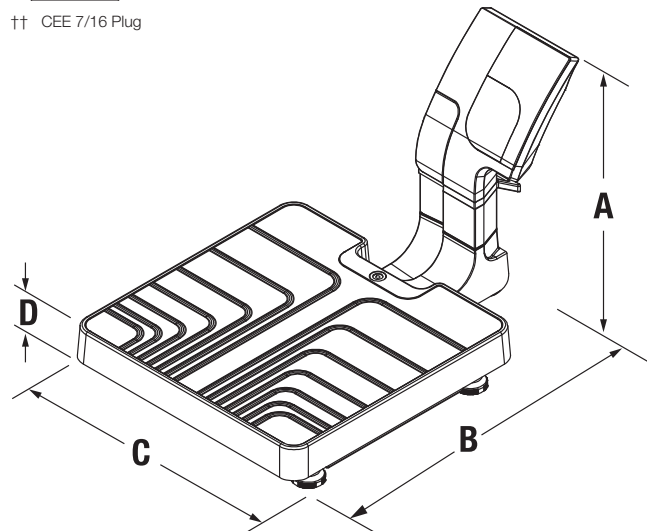

Dimensions

	Inches	Centimeters
A	12.70	32.3
B	22.40	56.9
C	14.70	37.4
D	3.00	7.6

160-10-7N

Digital Athletic Low-profile Scale

HEALTH SCALES



Approvals



Part Number/Price

Part #	Model #	Capacity	Price
193355	160-10-7N	550 × 0.2 lb (250 × 0.1 kg)	\$800.00

Shipping Weight

Part #	Model #	L × W × H	Package Wgt. (lb)	Dim Wgt. (lb)	Shipping Wgt. (lb)
193355	160-10-7N	20 × 18 × 6 in	18	16	18

Options/Accessories

Part #	Description	Price
107445	Carrying case	\$92.00



† NEMA 1-15 Plug

Standard Features

- Push-button LCD display
- Antimicrobial keypad
- Large, stable scale base
- Unit of measure toggle or locking
- Motiontrap™ movement compensation technology
- EMR capable
- Zero function
- Factory calibrated

Specifications

Capacity:

550 × 0.2 lb (250 × 0.1 kg)

Platform Dimensions:

(L × W × H)

14.40 × 14.40 × 1.65 in

Power:

9 VDC, provided by six AA alkaline batteries (included) or 120V/230V AC adapter, NEMA 1-15 plug (included)

Battery Type:

Six AA alkaline (included)

Battery Use:

25 hours continuous use with batteries
Automatic power-off can be configured

Display:

Five-digit LCD display, 0.75 in (1.9 cm) digit height

Cable Length:

6 ft (1.8 m) cable between scale base and indicator

Temperature:

Operating:
50 °F to 104 °F (10 °C to 40 °C)

Approvals:

NTEP 18-011

Warranty:

Two-year limited

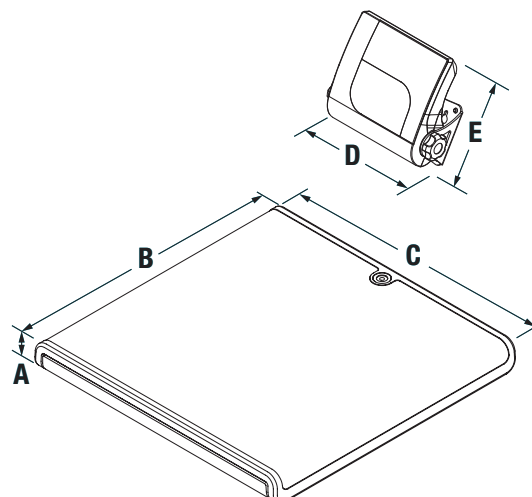

Dimensions

	Inches	Centimeters
A	1.7	4.3
B	14.4	36.6
C	14.4	36.6
D	7.8	20.0
E	6.7	17.0

RL-WMS-10

Wall Mount Stadiometer

HEALTH SCALES



Standard Features

- Aluminum construction
- Compact design with folding headpiece
- Measures both inches and centimeters
- Hardware included for mounting to metal, wood or drywall walls

Specifications

Measurement Range:

23 to 82 in (60 to 210 cm)

Height Divisions:

1/16 in (1 mm)

Warranty:

One-year limited



Part Number/Price

Part #	Model #	Measuring Range × Graduation Length	Price
206553	RL-WMS-10	23 to 82 × 1/16 in (60 to 120 cm × 1 mm)	\$103.00



Standard Features

- Painted beam
- Sturdy, enameled steel body
- Easy-to-clean ABS plastic tray
- Dual-read capacity; lb and kg
- Built-in measuring tape

Specifications

Capacity:
135 lb × 1 oz (62 kg × 20 g)

Measuring Tape:
Measures 0 to 23 in
(0 to 58 cm)

Warranty:
Two-year limited

Part Number/Price

Part #	Model #	Capacity	Price
131470	RL-MIS	135 lb × 1 oz (62 kg × 20 g)	\$370.00

Shipping Weight

Part #	Model #	L × W × H	Package Wgt. (lb)	Dim Wgt. (lb)	Shipping Wgt. (lb)
131470	RL-MIS	28 × 20 × 14 in	30	57	57

Dimensions

	Inches	Centimeters		Inches	Centimeters
A	24.00	61.0	D	16.50	41.9
B	27.00	68.6	E	2.70	6.8
C	21.50	54.5	F	13.39	34.0

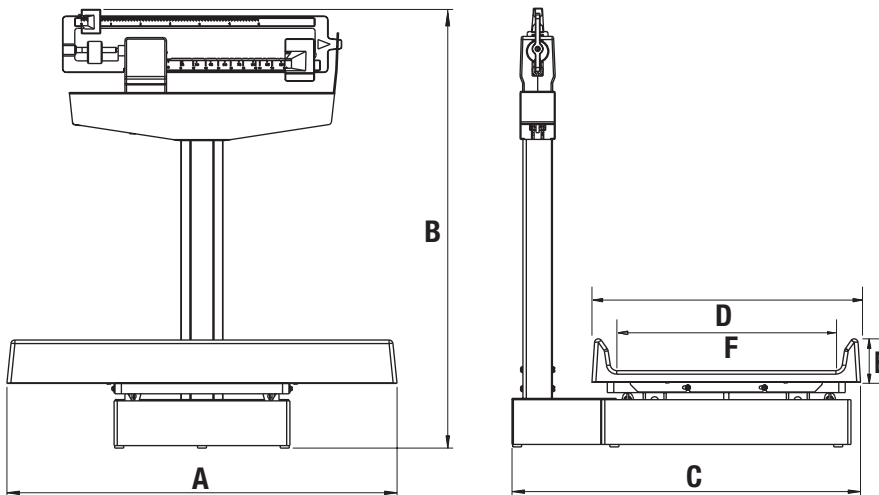

RL-MIS-20

Mechanical Baby Scale

HEALTH SCALES



Standard Features

- Painted beam
- Sturdy, enameled steel body
- Easy-to-clean ABS plastic tray
- Unit of measure: kg
- Built-in measuring tape

Specifications

Capacity:

70 kg × 20 g

Measuring Tape:

0 to 58 cm

Warranty:

Two-year limited

Part Number/Price

Part #	Model #	Capacity	Price
131471	RL-MIS-20	70 kg × 20 g	\$370.00

Shipping Weight

Part #	Model #	L × W × H	Package Wgt. (lb)	Dim Wgt. (lb)	Shipping Wgt. (lb)
131471	RL-MIS-20	28 × 20 × 14 in	30	57	57

Dimensions

	Centimeters		Centimeters
A	61.0	D	41.9
B	68.6	E	6.8
C	54.5	F	34.0

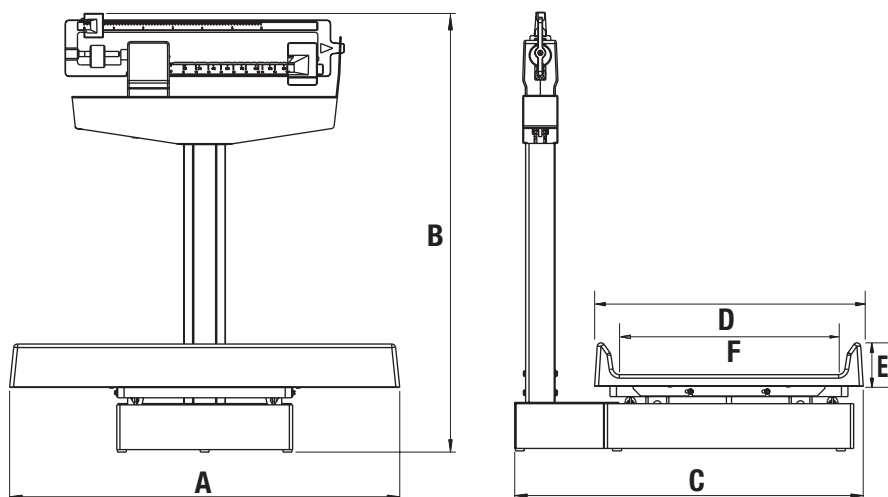



Standard Features

- Large 1-in LCD display
- Unit of measure locking
- Recall function to view last weight
- Automatic shut-off for long battery life
- Built-in measuring tape
- Optional carrying case

Specifications

Capacity:
44 lb × 0.5 oz (20 kg × 10 g)

Power:
Four AA alkaline batteries (included)
or AC adapter (included)

Battery Type:
Four AA alkaline (included)

Measuring Tape:
0 to 22.5 in (0 to 57 cm)

Approvals:
AC adapter: cULus

Warranty:
Two-year limited

Part Number/Price

Part #	Model #	Capacity	Price
107423	RL-DBS	44 lb × 0.5 oz (20 kg × 10 g), includes 120 VAC adapter	\$225.00
112571	RL-DBS	44 lb × 0.5 oz (20 kg × 10 g), includes 230 VAC adapter	\$225.00

Shipping Weight

Part #	Model #	L × W × H	Package Wgt. (lb)	Dim Wgt. (lb)	Shipping Wgt. (lb)
107423	RL-DBS 120 V	27 × 18 × 7 in	10	21	21
112571	RL-DBS 230 V	27 × 18 × 7 in	10	21	21

Options/Accessories

Part #	Description	Price
112570	Carrying case	\$56.00



Optional Transport/Carrying Case

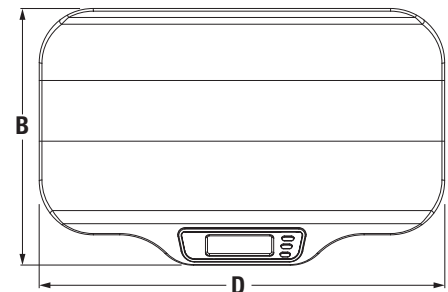
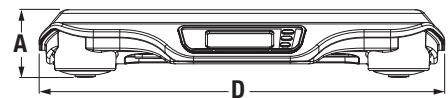
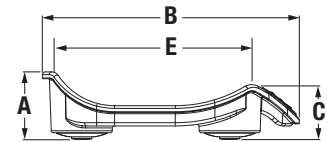

Dimensions

	Inches	Centimeters
A	3.90	9.9
B	15.00	38.1
C	3.10	7.8
D	23.60	59.9
E	11.00	27.9

RL-DBS-2

Digital Baby Scale

HEALTH SCALES



Standard Features

- Large 1-inch LCD display
- Dual-range capacity for increased precision
- Accuracy within 0.2 oz (5 g)
- Unit of measure locking
- Recall function to view last weight
- Automatic shut-off for long battery life
- Built-in measuring tape
- Optional carrying case

Specifications

Capacity:

Range 1: 0 to 22 lb × 0.2 oz
(0 to 10 kg × 5 g)
Range 2: 22 to 44 lb × 0.5 oz
(10 to 20 kg × 10 g)

Power:

Four AA alkaline batteries (included)
or AC adapter (included)

Battery Type:

Four AA alkaline (included)

Measuring Tape:

0 to 22.5 in (0 to 57 cm)

Approvals:

AC adapter: cULus

Warranty:

Two-year limited

Part Number/Price

Part #	Model #	Capacity	Price
155922	RL-DBS-2	0 to 22 lb × 0.2 oz, 22 to 44 lb × 0.5 oz (0 to 10 kg × 5 g, 10 to 20 kg × 10 g) includes 120 VAC adapter	\$265.00

Shipping Weight

Part #	Model #	L × W × H	Package Wgt. (lb)	Dim Wgt. (lb)	Shipping Wgt. (lb)
155922	RL-DBS-2 120 V	28 × 18 × 7 in	10	21	21

Options/Accessories

Part #	Description	Price
112570	Carrying Case	\$56.00



Optional Transport/Carrying Case

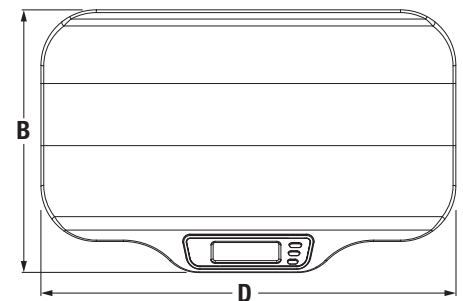
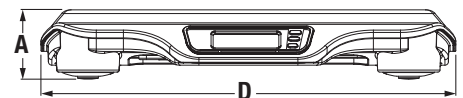
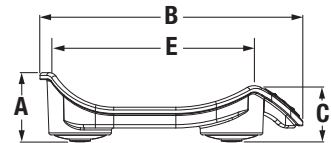

Dimensions

	Inches	Centimeters
A	3.90	9.9
B	15.00	38.1
C	3.10	7.8
D	23.60	59.9
E	11.00	27.9



Standard Features

- Large LCD display
- Dual-range capacity for increased precision
- Unit of measure locking
- Automatic shut-off for long battery life
- Motiontrap™ movement compensation technology
- Built-in measuring tape

Specifications

Capacity:

Range 1: 0 to 10 lb × 0.05 oz (0 to 5 kg × 1 g)
 Range 2: 10 to 33 lb × 0.1 oz (5 to 15 kg × 2 g)

Power:

12 VDC, provided by six AA lithium batteries (included) or AC adapter (optional)

Measuring Tape:

0 to 23.5 in × 0.125 in
 (0 to 60 cm × 0.25 cm)

Battery Type:

Six Li-FeS2 batteries

Temperature:

Operating:
 50 °F to 95 °F (10 °C to 35 °C)

Display:

Five-digit LCD display, 0.75 in (1.9 cm) digit height

Warranty:

Two-year limited

Part Number/Price

Part #	Model #	Capacity	Price
161784	650-10-1	0 to 10 lb × 0.05 oz, 10 to 33 lb × 0.1 oz (0 to 5 kg × 1 g, 5 to 15 kg × 2 g)	\$765.00

Shipping Weight

Part #	Model #	L × W × H	Package Wgt. (lb)	Dim Wgt. (lb)	Shipping Wgt. (lb)
161784	650-10-1	18 × 28 × 11 in	25	40	40

Options/Accessories

Part #	Description	Price
165138	12VDC adapter, 100-240V, NEMA 1-15 Plug, medical grade power supply	\$55.00

Dimensions

	Inches	Centimeters
A	23.94	60.8
B	16.95	43.1
C	6.29	16.0
D	10.50	26.7
E	3.11	7.9
F	13.34	33.9

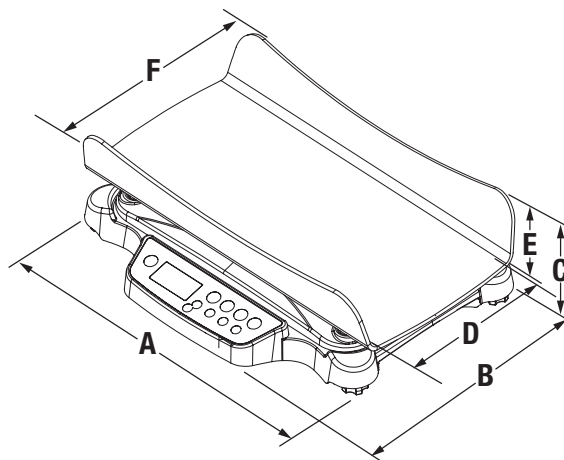

260-10-1

Bariatric Handrail Scale



Standard Features

- Large LCD display
- Antimicrobial keypad
- Handrails for support and safety
- Two wheels for easy transport
- Nonslip platform
- Unit of measure toggle or locking
- Motiontrap™ movement compensation technology
- EMR capable
- Tare function
- Hold function
- Body mass index (BMI) function
- Factory calibrated
- Optional height rod can be installed on-site

Specifications

Capacity:

800 × 0.2 lb (360 × 0.1 kg)

Platform Dimensions:

(L × W × H)
23.50 × 23.50 × 2.75 in

Optional Height Rod Dimensions:

30 to 83.12 in (77 to 211 cm)

Power:

9 VDC, provided by six AA alkaline batteries (included) or AC adapter (optional)

Battery Type:

Six AA alkaline (included)

Battery Use:

25 hours continuous use with batteries
Automatic power-off can be configured

Display:

Five-digit LCD display, 0.75 in (1.9 cm) digit height

Temperature:

Operating:
50 °F to 104 °F (10 °C to 40 °C)

Warranty:

Two-year limited

Part Number/Price

Part #	Model #	Capacity	Price
170139	260-10-1	800 × 0.2 lb (360 × 0.1 kg) with USB	\$1,685.00

Shipping Weight

Part #	Model #	L × W × H	Package Wgt. (lb)	Dim Wgt. (lb)	Shipping Wgt. (lb)
170139	260-10-1	40 × 40 × 10 in	58	116	116
172958	Height rod	33 × 9 × 3 in	3	7	7

Options/Accessories

Part #	Description	Price
133077 †	9VDC adapter, 100-240V, NEMA 1-15 Plug, cULus power supply	\$30.00
102508 ††	9VDC adapter, 100-240V, CEE 7/16 Plug, medical grade power supply	\$30.00
172958	Height rod 30 to 83 in (77 to 210 cm)	\$75.00



† NEMA 1-15 Plug

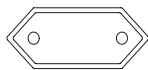

†† CEE 7/16 Plug

Dimensions

	Inches	Centimeters
A	23.50	59.7
B	23.50	59.7
C	2.75	7.0
D	25.50	64.8
E	33.50	85.1
F	43.00	109.2

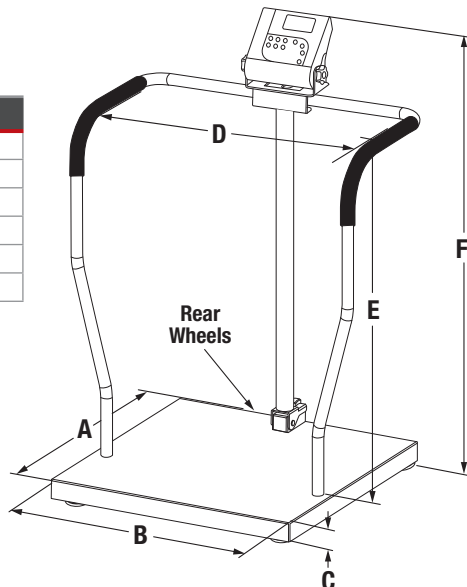



Standard Features

- ADA-compliant
- Large LCD display
- Antimicrobial keypad
- Handrails for support and safety
- Two wheels for easy transport
- Nonslip platform
- Unit of measure toggle or locking
- Motiontrap™ movement compensation technology
- EMR capable
- Serial and USB data communication ports
- Wireless personal area network (WPAN) option available
- Tare function
- Hold function
- Body mass index (BMI) function
- Factory calibrated

Specifications

Capacity:
1,000 × 0.2 lb (450 × 0.1 kg)

Platform Dimensions:
(L × W × H)
25.00 × 20.00 × 3.00 in

Power:
9 VDC, provided by six AA alkaline batteries (included) or AC adapter (optional)

Battery Type:
Six AA alkaline (included)

Battery Use:
25 hours continuous use with batteries
Automatic power-off can be configured

Display:
Five-digit LCD display, 0.75 in (1.9 cm) digit height

Temperature:
Operating:
50 °F to 104 °F (10 °C to 40 °C)

Warranty:
Two-year limited

Part Number/Price

Part #	Model #	Capacity	Price
133119	250-10-2	1,000 × 0.2 lb (450 × 0.1 kg) with USB	\$1,840.00
194733	250-10-2WPAN	1,000 × 0.2 lb (450 × 0.1 kg) WPAN	\$2,145.00

Shipping Weight

Part #	Model #	L × W × H	Package Wgt. (lb)	Dim Wgt. (lb)	Shipping Wgt. (lb)
133119	250-10-2	46 × 30 × 9 in	66	94	94
194733	250-10-2WPAN	46 × 30 × 9 in	66	94	94

Options/Accessories

Part #	Description	Price
115655 †	9VDC adapter, 100-240V, NEMA 1-15 Plug, medical grade power supply	\$43.00
133077 †	9VDC adapter, 100-240V, NEMA 1-15 Plug, cULus power supply	\$30.00
102508 ††	9VDC adapter, 100-240V, CEE 7/16 Plug, medical grade power supply	\$30.00



† NEMA 1-15 Plug

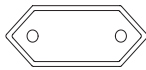

†† CEE 7/16 Plug

Dimensions

	Inches	Centimeters
A	20.00	50.8
B	25.00	63.5
C	3.00	7.6
D	25.00	63.5
E	32.84	83.4
F	34.34	87.2
G	44.50	113.0
H	21.71	55.1

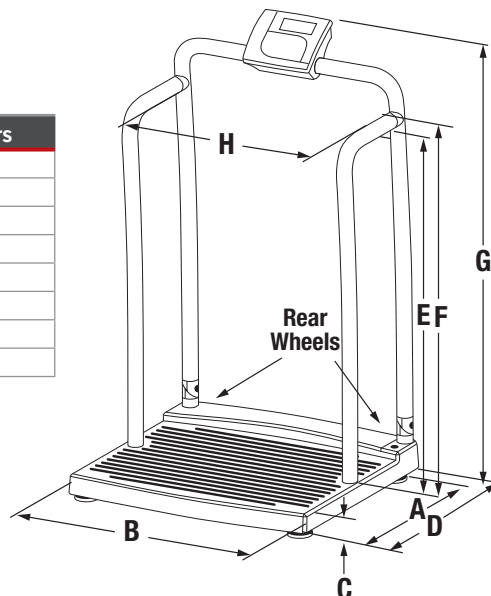

250-10-4

Bariatric Handrail Scale

HEALTH SCALES



20 INCH SEAT WIDTH

Standard Features

- Large LCD display
- Antimicrobial keypad
- Handrails for support and safety
- Padded seat with backrest
- Two wheels for easy transport
- Nonslip platform
- Unit of measure toggle or locking
- Motiontrap™ movement compensation technology
- EMR capable
- Serial and USB data communication ports
- Wireless personal area network (WPAN) option available
- Tare function
- Hold function
- Body mass index (BMI) function
- Factory calibrated

Specifications

Capacity:

1,000 × 0.2 lb (450 × 0.1 kg)

Platform Dimensions:

(L × W × H)
25.00 × 20.00 × 3.00 in

Power:

9 VDC, provided by six AA alkaline batteries (included) or AC adapter (optional)

Battery Type:

Six AA alkaline (included)

Battery Use:

25 hours continuous use with batteries
Automatic power-off can be configured

Display:

Five-digit LCD display, 0.75 in (1.9 cm) digit height

Temperature:

Operating:
50 °F to 104 °F (10 °C to 40 °C)

Warranty:

Two-year limited

Part Number/Price

Part #	Model #	Capacity	Price
133120	250-10-4	1,000 × 0.2 lb (450 × 0.1 kg) with USB	\$2,810.00
194734	250-10-4WPAN	1,000 × 0.2 lb (450 × 0.1 kg) WPAN	\$3,115.00

Shipping Weight

Part #	Model #	L × W × H	Package Wgt. (lb)	Dim Wgt. (lb)	Shipping Wgt. (lb)
133120	250-10-4	47 × 27 × 16 in	94	154	154
194734	250-10-4WPAN	47 × 27 × 16 in	94	154	154

Options/Accessories

Part #	Description	Price
115655 †	9VDC adapter, 100-240V, NEMA 1-15 Plug, medical grade power supply	\$43.00
133077 †	9VDC adapter, 100-240V, NEMA 1-15 Plug, cULus power supply	\$30.00
102508 ††	9VDC adapter, 100-240V, CEE 7/16 Plug, medical grade power supply	\$30.00



† NEMA 1-15 Plug

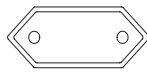

†† CEE 7/16 Plug

Dimensions

	Inches	Centimeters
A	3.00	7.6
B	25.70	65.3
C	25.20	64.0
D	21.60	54.9
E	32.00	81.1
F	47.50	120.7
G	20.00	50.8
H	12.00	30.5
I	36.00	91.4

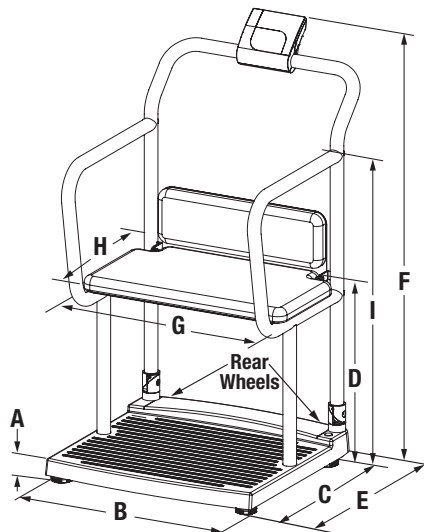



16 INCH
SEAT WIDTH

Standard Features

- Swing-up arms for easy access and exit
- Fold-up footrest
- Sturdy enameled, steel frame
- Dual read die-cast beam
- Polypropylene seat with ABS armrests
- Heavy-duty wheels; two back wheels lock, two front wheels swivel

Specifications

Capacity:
Lb only beam 450 lb × 4 oz
Kg only beam 200 kg × 100 g

Warranty:
Two-year limited

Part Number/Price

Part #	Model #	Capacity	Price
172098	RL-MCS-LB	450 lb × 4 oz	\$725.00
172099	RL-MCS-KG	200 kg × 100 g	\$725.00

Shipping Weight

Part #	Model #	L × W × H	Package Wgt. (lb)	Dim Wgt. (lb)	Shipping Wgt. (lb)
172098	RL-MCS-LB	29 × 25 × 25 in	79	131	131
172099	RL-MCS-KG	29 × 25 × 25 in	79	131	131

Dimensions

	Inches	Centimeters
A	21.50	54.6
B	14.20	36.1
C	14.80	37.6
D	16.00	40.6
E	25.38	64.5
F	38.40	97.5
G	35.70	90.7

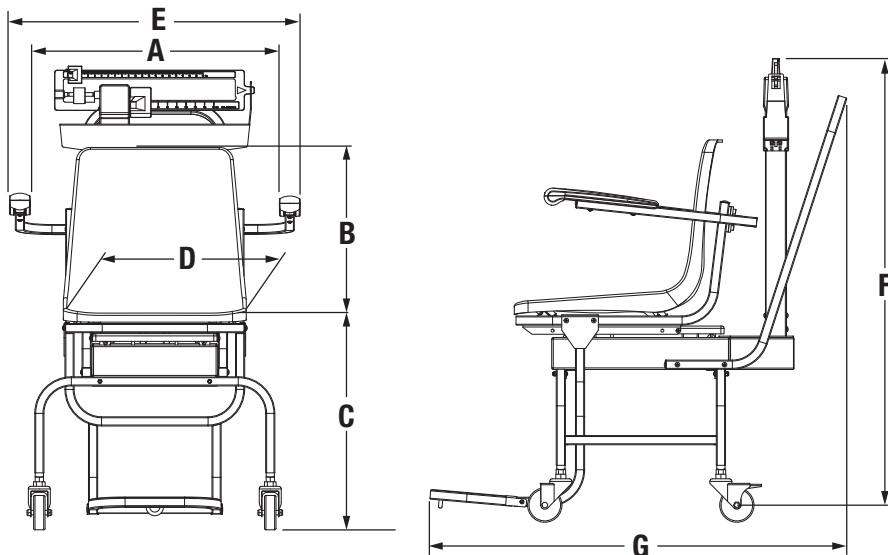

560-10-1

Digital Chair Scale

HEALTH SCALES



20 INCH SEAT WIDTH

Standard Features

- Large LCD display
- Enameled tubular steel frame
- Four heavy-duty caster wheels
- Swing-up arms
- Side-folding footrests
- Molded seat
- Motiontrap™ movement compensation technology
- Unit of measure toggle or locking
- EMR capable
- USB data communication port
- Tare function
- Hold function
- Body mass index (BMI) function
- Factory calibrated

Specifications

Capacity:

660 × 0.2 lb (300 × 0.1 kg)

Power:

9 VDC, provided by six AA alkaline batteries (included) or AC adapter (optional)

Battery Type:

Six AA alkaline (included)

Battery Use:

25 hours continuous use with batteries
Automatic power-off can be configured

Display:

Five-digit LCD display, 0.75 in (1.9 cm) digit height

Warranty:

Two-year limited

Part Number/Price

Part #	Model #	Capacity	Price
166644	560-10-1	660 × 0.2 lb (300 × 0.1 kg)	\$1,675.00

Shipping Weight

Part #	Model #	L × W × H	Package Wgt. (lb)	Dim Wgt. (lb)	Shipping Wgt. (lb)
166644	560-10-1	33 × 23 × 27 in	65	148	148

Options/Accessories

Part #	Description	Price
133077 †	9VDC adapter, 100-240V, NEMA 1-15 Plug, cULus power supply	\$30.00
102508 ††	9VDC adapter, 100-240V, CEE 7/16 Plug, medical grade power supply	\$30.00



† NEMA 1-15 Plug



†† CEE 7/16 Plug



Dimensions

	Inches	Centimeters
A	20.10	51.1
B	17.30	44.0
C	20.10	51.1
D	36.40	92.5
E	5.90	15.0
F	21.50	54.6
G	34.60	88.0
H	42.90	109.0

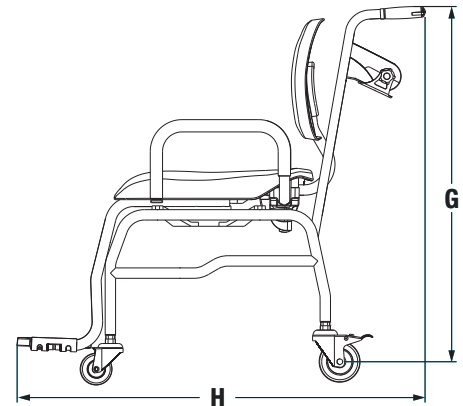
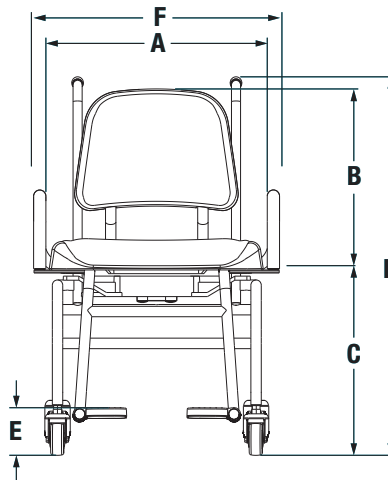



17 INCH SEAT WIDTH

Standard Features

- Large LCD display
- Antimicrobial keypad
- Enameled tubular steel frame
- Four heavy-duty locking caster wheels
- Swing-up arms
- Flip-up footrest
- Motiontrap™ movement compensation technology
- Unit of measure toggle or locking
- EMR capable
- Serial and USB data communication ports
- Wireless personal area network (WPAN) option available
- Tare function
- Hold function
- Body mass index (BMI) function
- Factory calibrated

Specifications

Capacity:
660 × 0.2 lb (300 × 0.1 kg)

Power:
9 VDC, provided by six AA alkaline batteries (included) or AC adapter (optional)

Battery Type:
Six AA alkaline (included)

Battery Use:
25 hours continuous use with batteries
Automatic power-off can be configured

Display:
Five-digit LCD display, 0.75 in (1.9 cm) digit height

Temperature:
Operating:
50 °F to 104 °F (10 °C to 40 °C)

Warranty:
Two-year limited

Part Number/Price

Part #	Model #	Capacity	Price
119114	550-10-1	660 × 0.2 lb (300 × 0.1 kg) with USB	\$1,610.00
194740	550-10-1WPAN	660 × 0.2 lb (300 × 0.1 kg) WPAN	\$1,915.00

Shipping Weight

Part #	Model #	L × W × H	Package Wgt. (lb)	Dim Wgt. (lb)	Shipping Wgt. (lb)
119114	550-10-1	29 × 27 × 29 in	54	164	164
194740	550-10-1WPAN	29 × 27 × 29 in	54	164	164

Options/Accessories

Part #	Description	Price
115655 †	9VDC adapter, 100-240V, NEMA 1-15 Plug, medical grade power supply	\$43.00
133077 †	9VDC adapter, 100-240V, NEMA 1-15 Plug, cULus power supply	\$30.00
102508 ††	9VDC adapter, 100-240V, CEE 7/16 Plug, medical grade power supply	\$30.00



† NEMA 1-15 Plug

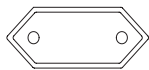

†† CEE 7/16 Plug

Dimensions

	Inches	Centimeters
A	37.26	94.6
B	15.61	39.6
C	20.74	52.7
D	2.15	5.5
E	25.06	63.7
F	20.70	52.6
G	35.78	90.9
H	33.58	85.3
I	12.95	32.9

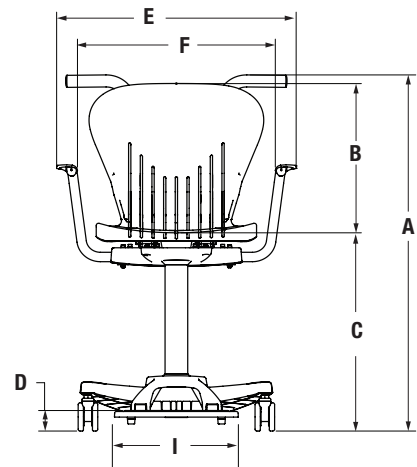
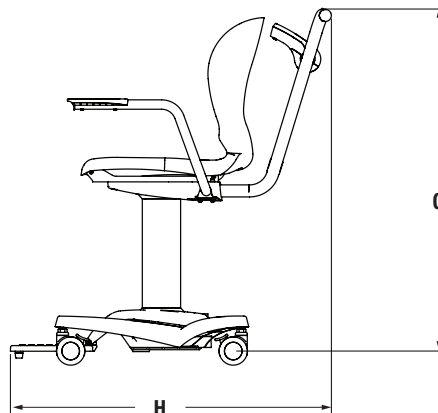

350-ADA-1

Dual-ramp ADA Compliant Wheelchair Scale



Standard Features

- ADA -compliant
- Large LCD display
- Antimicrobial keypad
- Dual ramp
- Metal, nonslip platform
- Supports bariatric patient weighing
- 2-in edge protection
- 1:8 gentle slope
- Two wheels for easy transport
- Motiontrap™ movement compensation technology
- Unit of measure toggle or locking
- EMR capable
- Serial and USB data communication ports
- Tare function
- Hold function
- Body mass index (BMI) function
- Factory calibrated
- Easy to store, folded depth is 11.75 in (29.8 cm)

Specifications

Capacity:

1,000 × 0.2 lb (450 × 0.1 kg)

Platform Dimensions:

(L × W × H)

40.60 × 32.00 × 4.50 in

Power:

9 VDC, provided by six AA alkaline batteries (included) or AC adapter (optional)

Battery Type:

Six AA alkaline (included)

Battery Use:

25 hours of continuous use with batteries
Automatic power-off can be configured

Display:

Five-digit LCD display, 0.75 in (1.9 cm) digit height

Temperature:

Operating:
50 °F to 104 °F (10 °C to 40 °C)

Warranty:

Two-year limited

Part Number/Price

Part #	Model #	Capacity	Price
231628	350-ADA-1	1,000 × 0.2 lb (450 × 0.1 kg) with USB	Consult

Shipping Weight

Part #	Model #	L × W × H	Package Wgt. (lb)	Dim Wgt. (lb)	Shipping Wgt. (lb)
231628	350-ADA-1	43 × 48 × 25 in	145	NA	287

Options/Accessories

Part #	Description	Price
133077 †	9 VDC adapter, 120 V/230 V auto switching	Consult



† NEMA 1-15 Plug

Dimensions

	Inches	Centimeters
A	44.40	113.0
B	35.90	91.0
C	36.40	92.5
D	32.00	81.3
E	83.50	212.0
F	40.60	103.0
G	4.50	11.5
H	2.50	6.4
I	2.00	5.1

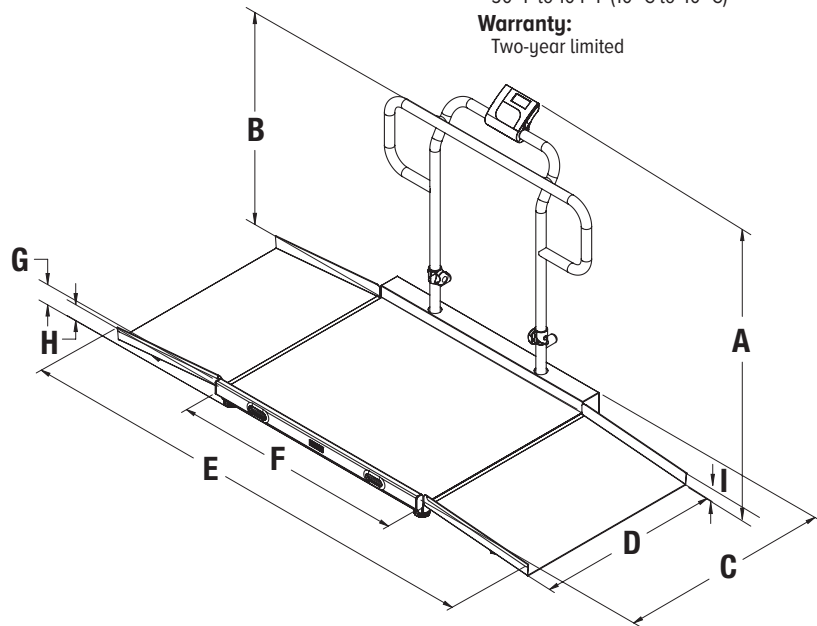

350-10-3M

Dual-ramp Wheelchair Scale



Standard Features

- Large LCD display
- Antimicrobial keypad
- Two wheels for easy transport
- Dual ramp
- Metal, nonslip platform
- Motiontrap™ movement compensation technology
- Unit of measure toggle or locking
- EMR capable
- Serial and USB data communication ports
- Wireless personal area network (WPAN) option available
- Tare function
- Hold function
- Body mass index (BMI) function
- Factory calibrated
- Easy to store, folded depth is 11.75 in (29.8 cm)

Specifications

Capacity:
1,000 × 0.2 lb (450 × 0.1 kg)

Platform Dimensions:
(L × W × H)
29.50 × 31.50 × 3.15 in

Power:
9 VDC, provided by six AA alkaline batteries (included) or AC adapter (optional)

Battery Type:
Six AA alkaline (included)

Battery Use:
25 hours of continuous use with batteries
Automatic power-off can be configured

Display:
Five-digit LCD display, 0.75 in (1.9 cm) digit height

Temperature:
Operating:
50 °F to 104 °F (10 °C to 40 °C)

Warranty:
Two-year limited

Part Number/Price

Part #	Model #	Capacity	Price
193956	350-10-3M	1,000 × 0.2 lb (450 × 0.1 kg) with USB	\$3,115.00
203910	350-10-3MWPAN	1,000 × 0.2 lb (450 × 0.1 kg) WPAN	\$3,420.00

Shipping Weight

Part #	Model #	L × W × H	Package Wgt. (lb)	Dim Wgt. (lb)	Shipping Wgt. (lb)
193956	350-10-3M	51 × 42 × 14 in	102	216	216
203910	350-10-3MWPAN	51 × 42 × 14 in	102	216	216

Options/Accessories

Part #	Description	Price
115655 †	9 VDC adapter, 120 V/230 V auto switching medical grade power supply	\$43.00
133077 †	9VDC adapter, 100-240V, NEMA 1-15 Plug, cULus power supply	\$30.00
102508 ††	9VDC adapter, 100-240V, CEE 7/16 Plug, medical grade power supply	\$30.00



† NEMA 1-15 Plug

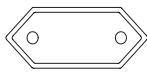

†† CEE 7/16 Plug

Dimensions

	Inches	Centimeters
A	3.15	8.0
B	47.70	121.2
C	37.80	96.0
D	45.30	115.1
E	31.50	80.0
F	29.50	74.9
G	2.40	6.1
H	27.20	69.1

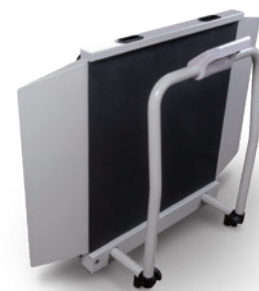
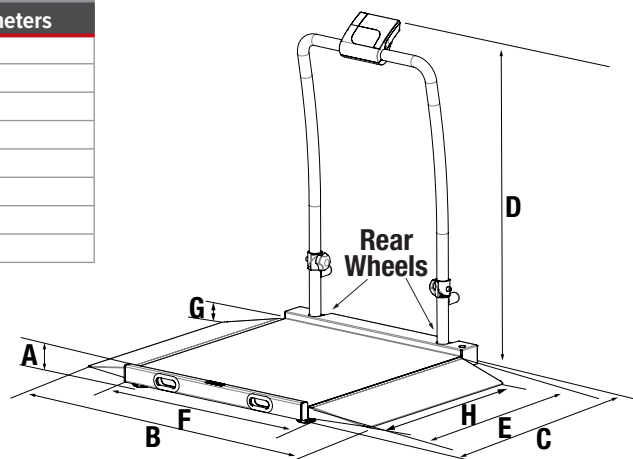

350-10-3M in folded position

350-10-2

Single-ramp Wheelchair Scale

HEALTH SCALES



Standard Features

- Large LCD display
- Antimicrobial keypad
- Two wheels for easy transport
- Single ramp
- Nonslip platform
- Motiontrap™ movement compensation technology
- Unit of measure toggle or locking
- EMR capable
- Serial and USB data communication ports
- Wireless personal area network (WPAN) option available
- Tare function
- Hold function
- BMI (body mass index) function
- Factory calibrated
- Easy to store, folded depth is 11.75 in (29.8 cm)

Specifications

Capacity:

1,000 × 0.2 lb (450 × 0.1 kg)

Platform Dimensions Without Ramp:

(L × W × H)
29.50 × 32.00 × 2.40 in

Power:

9 VDC, provided by six AA alkaline batteries (included) or AC adapter (optional)

Battery Type:

Six AA alkaline (included)

Battery Use:

25 hours of continuous use with batteries
Automatic power-off can be configured

Display:

Five-digit LCD display, 0.75 in (1.9 cm) digit height

Temperature:

Operating:
50 °F to 104 °F (10 °C to 40 °C)

Warranty:

Two-year limited

Part Number/Price

Part #	Model #	Capacity	Price
141445	350-10-2	1,000 × 0.2 lb (450 × 0.1 kg) with USB	\$2,125.00
194739	350-10-2WPAN	1,000 × 0.2 lb (450 × 0.1 kg) WPAN	\$2,475.00

Shipping Weight

Part #	Model #	L × W × H	Package Wgt. (lb)	Dim Wgt. (lb)	Shipping Wgt. (lb)
141445	350-10-2	42 × 41 × 14 in	90	174	174
194739	350-10-2WPAN	42 × 41 × 14 in	90	174	174

Options/Accessories

Part #	Description	Price
115655 †	9VDC adapter, 100-240V, NEMA 1-15 Plug, medical grade power supply	\$43.00
133077 †	9VDC adapter, 100-240V, NEMA 1-15 Plug, cULus power supply	\$30.00
102508 ††	9VDC adapter, 100-240V, CEE 7/16 Plug, medical grade power supply	\$30.00



† NEMA 1-15 Plug

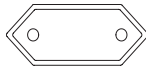

†† CEE 7/16 Plug

Dimensions

	Inches	Centimeters
A	29.50	74.9
B	32.00	81.3
C	2.40	6.1
D	9.30	23.6
E	37.50	95.3
F	45.00	114.3

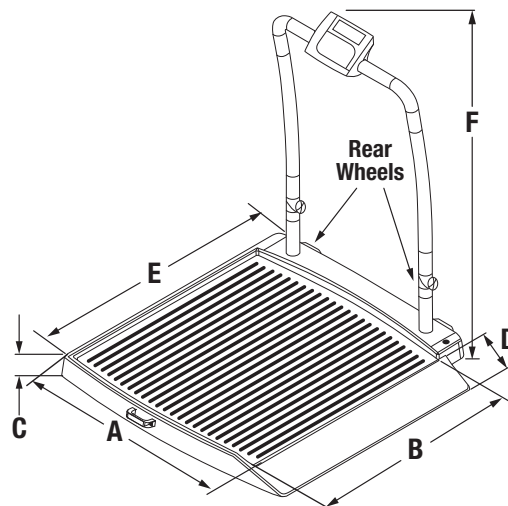

Wheelchair scale in folded position



Standard Features

- Large LCD display
- Antimicrobial keypad
- Two wheels for easy transport
- Single ramp
- Nonslip platform
- Motiontrap™ movement compensation technology
- Unit of measure toggle or locking
- EMR capable
- Serial and USB data communication ports
- Wireless personal area network (WPAN) option available
- Tare function
- Hold function
- Body mass index (BMI) function
- Factory calibrated

Specifications

Capacity:

1,000 × 0.2 lb (450 × 0.1 kg)

Platform Dimensions Without Ramp:

(L × W × H)
29.50 × 32.00 × 2.40 in

Power:

9 VDC, provided by six AA alkaline batteries (included) or AC adapter (optional)

Battery Type:

Six AA alkaline (included)

Battery Use:

25 hours of continuous use with batteries
Automatic power-off can be configured

Cable Length:

7 ft (2.1 m) cable between scale base and indicator

Display:

Five-digit LCD display, 0.75 in (1.9 cm) digit height

Temperature:

Operating:
50 °F to 104 °F (10 °C to 40 °C)

Warranty:

Two-year limited

Part Number/Price

Part #	Model #	Capacity	Price
141446	350-10-7	1,000 × 0.2 lb (450 × 0.1 kg) with USB	\$2,280.00
194738	350-10-7WPAN	1,000 × 0.2 lb (450 × 0.1 kg) WPAN	\$2,780.00

Shipping Weight

Part #	Model #	L × W × H	Package Wgt. (lb)	Dim Wgt. (lb)	Shipping Wgt. (lb)
141446	350-10-7	45 × 44 × 7 in	78	100	100
194738	350-10-7WPAN	45 × 44 × 7 in	78	100	100

Options/Accessories

Part #	Description	Price
115655 †	9VDC adapter, 100-240V, NEMA 1-15 Plug, medical grade power supply	\$43.00
133077 †	9VDC adapter, 100-240V, NEMA 1-15 Plug, cULus power supply	\$30.00
102508 ††	9VDC adapter, 100-240V, CEE 7/16 Plug, medical grade power supply	\$30.00



† NEMA 1-15 Plug

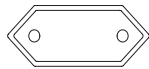

†† CEE 7/16 Plug

Dimensions

	Inches	Centimeters
A	29.50	74.9
B	32.00	81.3
C	2.40	6.1
D	9.30	23.6
E	37.50	95.3

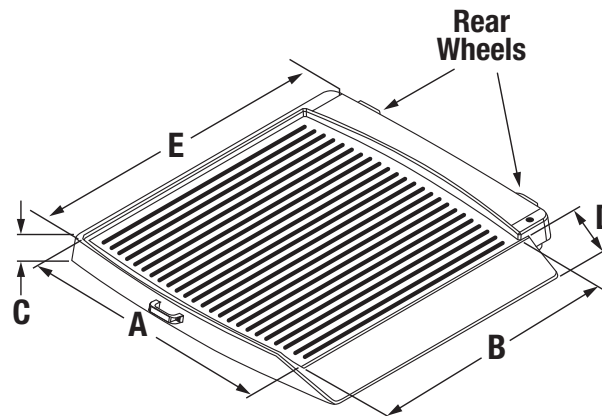

350-10-3

Dual-ramp Wheelchair Scale

HEALTH SCALES



Standard Features

- Large LCD display
- Antimicrobial keypad
- Two wheels for easy transport
- Dual ramp
- Nonslip platform
- Motiontrap™ movement compensation technology
- Unit of measure toggle or locking
- EMR capable
- Serial and USB data communication ports
- Wireless personal area network (WPAN) option available
- Tare function
- Hold function
- Body mass index (BMI) function
- Factory calibrated
- Easy to store, folded depth is 11.75 in (29.8 cm)

Specifications

Capacity:

1,000 × 0.2 lb (450 × 0.1 kg)

Platform Dimensions Without Ramps:

(L × W × H)

29.50 × 32.00 × 2.40 in

Power:

9 VDC, provided by six AA alkaline batteries (included) or AC adapter (optional)

Battery Type:

Six AA alkaline (included)

Battery Use:

25 hours of continuous use with batteries
Automatic power-off can be configured

Display:

Five-digit LCD display, 0.75 in (1.9 cm) digit height

Temperature:

Operating:
50 °F to 104 °F (10 °C to 40 °C)

Warranty:

Two-year limited

Part Number/Price

Part #	Model #	Capacity	Price
141447	350-10-3	1,000 × 0.2 lb (450 × 0.1 kg) with USB	\$2,820.00
194736	350-10-3WPAN	1,000 × 0.2 lb (450 × 0.1 kg) WPAN	\$3,125.00

Shipping Weight

Part #	Model #	L × W × H	Package Wgt. (lb)	Dim Wgt. (lb)	Shipping Wgt. (lb)
141447	350-10-3	51 × 42 × 14 in	102	216	216
194736	350-10-3WPAN	51 × 42 × 14 in	102	216	216

Options/Accessories

Part #	Description	Price
115655 †	9VDC adapter, 100-240V, NEMA 1-15 Plug, medical grade power supply	\$43.00
133077 †	9VDC adapter, 100-240V, NEMA 1-15 Plug, cULus power supply	\$30.00
102508 ††	9VDC adapter, 100-240V, CEE 7/16 Plug, medical grade power supply	\$30.00



† NEMA 1-15 Plug

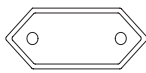

†† CEE 7/16 Plug

Dimensions

	Inches	Centimeters
A	48.50	123.2
B	32.00	81.3
C	2.40	6.1
D	9.30	23.6
E	38.00	96.5
F	45.00	114.3
G	29.50	74.90

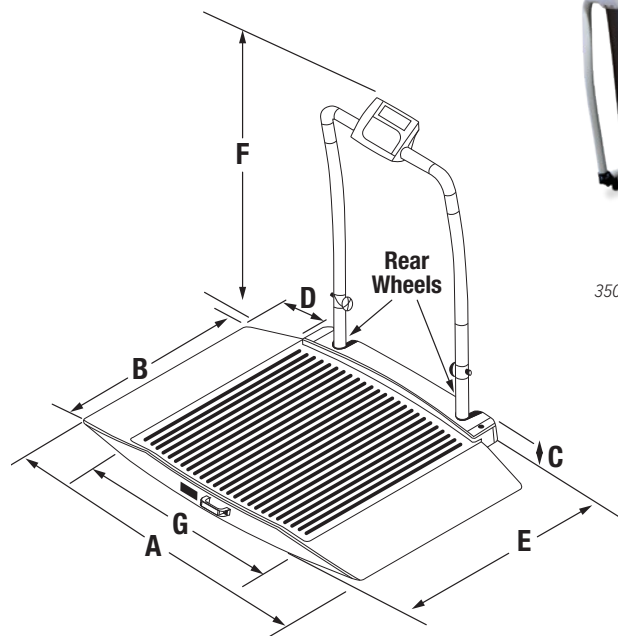

350-10-3 in folded position



WITH SEAT AND HANDRAIL

Standard Features

- Large LCD display
- Antimicrobial keypad
- Two wheels for portability
- Dual ramp
- Nonslip platform
- Fold-away padded seat with backrest
- Motiontrap™ movement compensation technology
- Unit of measure toggle or locking
- EMR capable
- Serial and USB data communication ports
- Wireless personal area network (WPAN) option available
- Tare function
- Hold function
- Body mass index (BMI) function
- Factory calibrated
- Easy to store, folded depth is 11.75 in (29.8 cm)

Specifications

Capacity:

1,000 × 0.2 lb (450 × 0.1 kg)

Platform Dimensions Without Ramps:

(L × W × H)
29.50 × 32.00 × 2.40 in

Power:

9 VDC, provided by six AA alkaline batteries (included) or AC adapter (optional)

Battery Type:

Six AA alkaline (included)

Battery Use:

25 hours of continuous use with batteries
Automatic power-off can be configured

Display:

Five-digit LCD display, 0.75 in (1.9 cm) digit height

Temperature:

Operating:
50 °F to 104 °F (14 °C to 40 °C)

Warranty:

Two-year limited

Part Number/Price

Part #	Model #	Capacity	Price
141448	350-10-4	1,000 × 0.2 lb (450 × 0.1 kg) with USB	\$4,050.00
194737	350-10-4WPAN	1,000 × 0.2 lb (450 × 0.1 kg) WPAN	\$4,355.00

Shipping Weight

Part #	Model #	L × W × H	Package Wgt. (lb)	Dim Wgt. (lb)	Shipping Wgt. (lb)
141448	350-10-4	51 × 43 × 21 in	132	332	332
194737	350-10-4WPAN	51 × 43 × 21 in	132	332	332

Options/Accessories

Part #	Description	Price
115655 †	9VDC adapter, 100-240V, NEMA 1-15 Plug, medical grade power supply	\$43.00
133077 †	9VDC adapter, 100-240V, NEMA 1-15 Plug, cULus power supply	\$30.00
102508 ††	9VDC adapter, 100-240V, CEE 7/16 Plug, medical grade power supply	\$30.00



† NEMA 1-15 Plug

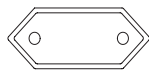

†† CEE 7/16 Plug

Dimensions

	Inches	Centimeters
A	48.50	123.2
B	32.00	81.3
C	2.40	6.1
D	9.30	23.6
E	38.00	96.5
F	45.00	114.3
G	11.42	29.0
H	15.75	40.0

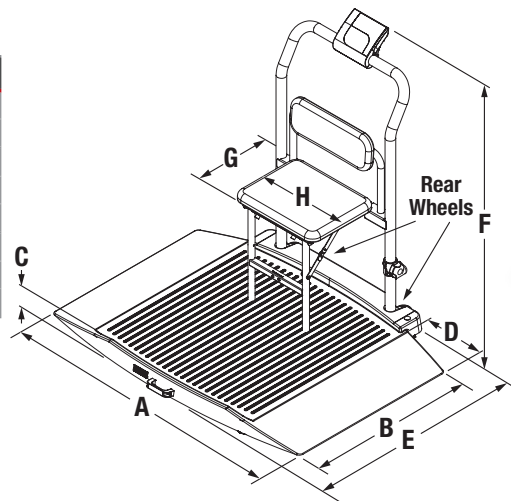

350-10-4 in folded position

350-10-8

Dual-ramp Wheelchair Platform Scale

HEALTH SCALES



Standard Features

- Large LCD display
- Antimicrobial keypad
- Two wheels for easy transport
- Dual ramp
- Nonslip platform
- Motiontrap™ movement compensation technology
- Unit of measure toggle or locking
- EMR capable
- Serial and USB data communication ports
- Wireless personal area network (WPAN) option available
- Tare function
- Hold function
- Body mass index (BMI) function
- Factory calibrated

Specifications

Capacity:

1,000 × 0.2 lb (450 × 0.1 kg)

Platform Dimensions Without Ramps:

(L × W × H)

29.50 × 32.00 × 2.40 in

Power:

9 VDC, provided by six AA alkaline batteries (included) or AC adapter (optional)

Battery Type:

Six AA alkaline (included)

Battery Use:

25 hours of continuous use with batteries
Automatic power-off can be configured

Cable Length:

7 ft (2.1 m) cable between scale base and indicator

Display:

Five-digit LCD display, 0.75 in (1.9 cm) digit height

Temperature:

Operating:
50 °F to 104 °F (10 °C to 40 °C)

Warranty:

Two-year limited

Part Number/Price

Part #	Model #	Capacity	Price
141449	350-10-8	1,000 × 0.2 lb (450 × 0.1 kg) with USB	\$2,770.00
194735	350-10-8WPAN	1,000 × 0.2 lb (450 × 0.1 kg) WPAN	\$3,070.00

Shipping Weight

Part #	Model #	L × W × H	Package Wgt. (lb)	Dim Wgt. (lb)	Shipping Wgt. (lb)
141449	350-10-8	53 × 45 × 7 in	86	121	121
194735	350-10-8WPAN	53 × 45 × 7 in	86	121	121

Options/Accessories

Part #	Description	Price
115655 †	9VDC adapter, 100-240V, NEMA 1-15 Plug, medical grade power supply	\$43.00
133077 †	9VDC adapter, 100-240V, NEMA 1-15 Plug, cULus power supply	\$30.00
102508 ††	9VDC adapter, 100-240V, CEE 7/16 Plug, medical grade power supply	\$30.00



† NEMA 1-15 Plug



†† CEE 7/16 Plug

Dimensions

	Inches	Centimeters
A	48.50	123.2
B	32.00	81.3
C	2.40	6.1
D	9.30	23.6
E	38.00	96.5
F	29.50	74.9

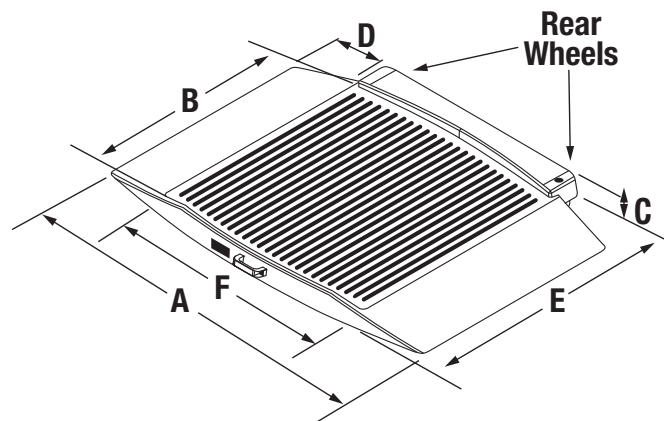

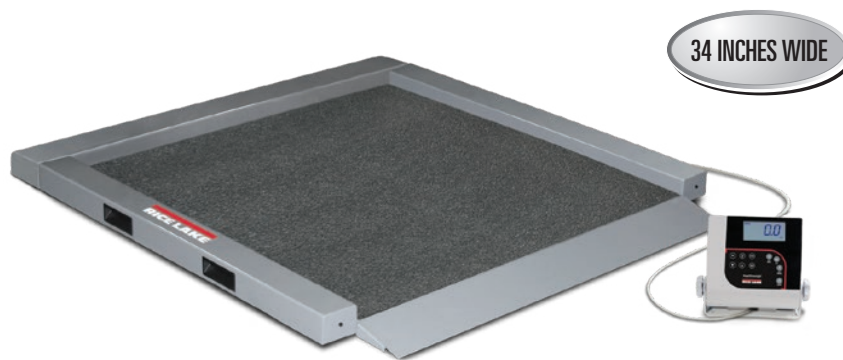

Standard Features

- Large LCD display
- Antimicrobial keypad
- Integrated handles and wheels for easy transport
- Large, stable scale base
- Metal, nonslip platform
- Motiontrap™ movement compensation technology
- Unit of measure toggle or locking
- EMR capable
- Serial and USB data communication ports
- Wireless personal area network (WPAN) option available
- Tare function
- Hold function
- Body mass index (BMI) function
- Factory calibrated

Part Number/Price

Part #	Model #	Capacity	Price
150703	RL-350-5	1,000 × 0.2 lb (450 × 0.1 kg) with USB	\$2,925.00
205976	RL-350-5WPAN	1,000 × 0.2 lb (450 × 0.1 kg) WPAN	\$3,200.00

Shipping Weight

Part #	Model #	L × W × H	Package Wgt. (lb)	Dim Wgt. (lb)	Shipping Wgt. (lb)
150703	RL-350-5	43 × 43 × 11 in	154	147	154
205976	RL-350-5WPAN	43 × 43 × 11 in	154	147	154

Options/Accessories

Part #	Description	Price
133077 †	9VDC adapter, 100-240V, NEMA 1-15 Plug, cULus power supply	\$30.00
102508 ††	9VDC adapter, 100-240V, CEE 7/16 Plug, medical grade power supply	\$30.00



† NEMA 1-15 Plug

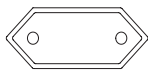

†† CEE 7/16 Plug

Dimensions

	Inches	Centimeters
A	41.00	104.1
B	40.00	101.6
C	2.20	5.6
D	34.00	86.4
E	34.00	86.4
F	3.70	9.4

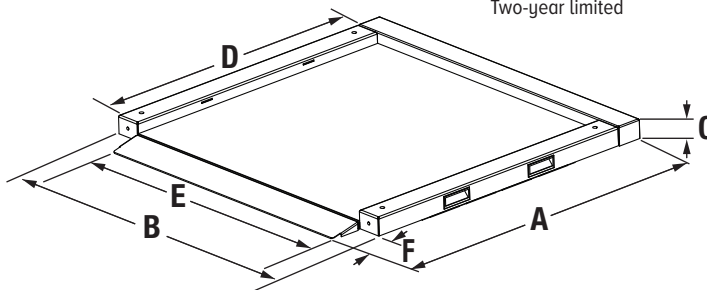

Specifications

Capacity:

1,000 × 0.2 lb (450 × 0.1 kg)

Platform Dimensions Without Ramp:

(L × W × H)
34.00 × 34.00 × 2.20 in

Power:

9 VDC, provided by six AA alkaline batteries (included) or AC adapter (optional)

Battery Type:

Six AA alkaline (included)

Battery Use:

25 hours of continuous use with batteries
Automatic power-off can be configured

Cable Length:

9 ft (2.7 m) cable between scale base and indicator

Display:

Five-digit LCD display, 0.75 in (1.9 cm) digit height

Temperature:

Operating:
50 °F to 104 °F (10 °C to 40 °C)

Warranty:

Two-year limited

RL-350-6

Dual-ramp Portable Bariatric Wheelchair Scale

HEALTH SCALES

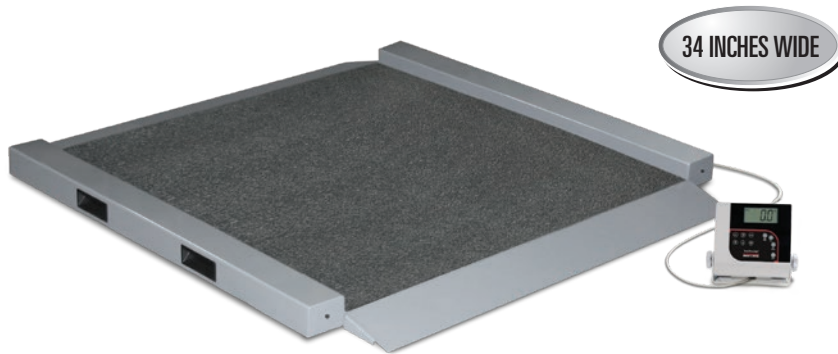

Standard Features

- Large LCD display
- Antimicrobial keypad
- Integrated handles and wheels for easy transport
- Dual ramp
- Large, stable scale base
- Metal, nonslip platform
- Unit of measure toggle or locking
- Motiontrap™ movement compensation technology
- EMR capable
- Serial and USB data communication ports
- Wireless personal area network (WPAN) option available
- Tare function
- Hold function
- Body mass index (BMI) function
- Factory calibrated

Part Number/Price

Part #	Model #	Capacity	Price
150704	RL-350-6	1,000 × 0.2 lb (450 × 0.1 kg) with USB	\$3,000.00
205974	RL-350-6WPAN	1,000 × 0.2 lb (450 × 0.1 kg) WPAN	\$3,275.00

Shipping Weight

Part #	Model #	L × W × H	Package Wgt. (lb)	Dim Wgt. (lb)	Shipping Wgt. (lb)
150704	RL-350-6	43 × 43 × 11in	162	147	162
205974	RL-350-6WPAN	43 × 43 × 11in	162	147	162

Options/Accessories

Part #	Description	Price
133077 †	9VDC adapter, 100-240V, NEMA 1-15 Plug, cULus power supply	\$30.00
102508 ††	9VDC adapter, 100-240V, CEE 7/16 Plug, medical grade power supply	\$30.00



† NEMA 1-15 Plug

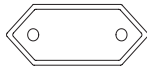

†† CEE 7/16 Plug

Dimensions

	Inches	Centimeters
A	41.00	104.1
B	40.00	101.6
C	2.20	5.6
D	34.00	86.4
E	34.00	86.4
F	3.70	9.4

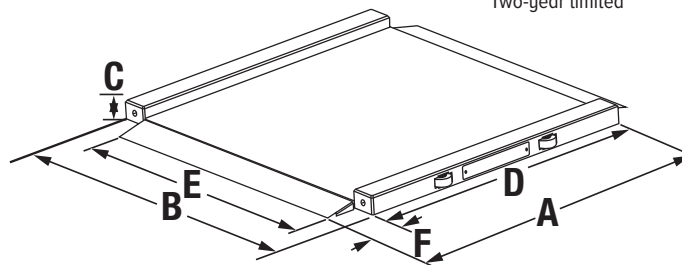

Specifications

Capacity:

1,000 × 0.2 lb (450 × 0.1 kg)

Platform Dimensions Without Ramps:

(L × W × H)
34.00 × 34.00 × 2.20 in

Power:

9 VDC, provided by six AA alkaline batteries (included) or AC adapter (optional)

Battery Type:

Six AA alkaline (included)

Battery Use:

25 hours of continuous use with batteries
Automatic power-off can be configured

Cable Length:

9 ft (2.7 m) cable between scale base and indicator

Display:

5-digit LCD display, 0.75 in (1.9 cm) digit height

Temperature:

Operating:
50 °F to 104 °F (10 °C to 40 °C)

Warranty:

Two-year limited

SB-1150 Summit™

Bariatric Wheelchair Scale



Standard Features

- Large LCD display
- Antimicrobial keypad
- Heavy-duty mild steel construction
- Single ramp
- Metal, nonslip platform
- Motiontrap™ movement compensation technology
- Unit of measure toggle or locking
- EMR capable
- Serial and USB data communication ports
- Wireless personal area network (WPAN) option available
- Tare function
- Hold function
- Body mass index (BMI) function
- Factory calibrated

Part Number/Price

Part #	Model #	Capacity	Price
150706	SB-1150	1,000 × 0.2 lb (450 × 0.1 kg) with USB	\$3,185.00
205977	SB-1150WPAN	1,000 × 0.2 lb (450 × 0.1 kg) WPAN	\$3,490.00

Shipping Weight

Part #	Model #	L × W × H	Package Wgt. (lb)	Dim Wgt. (lb)	Shipping Wgt. (lb)
150706	SB-1150	49 × 48 × 24 in	363	407	407
205977	SB-1150WPAN	49 × 48 × 24 in	363	407	407

Options/Accessories

Part #	Description	Price
133077 †	9VDC adapter, 100-240V, NEMA 1-15 Plug, cULus power supply	\$30.00



† NEMA 1-15 Plug



†† CEE 7/16 Plug

Dimensions

	Inches	Centimeters
A	36.00	91.4
B	36.00	91.4
C	28.50	72.4
D	36.00	91.4
E	4.00	10.2
F	1.00	2.5

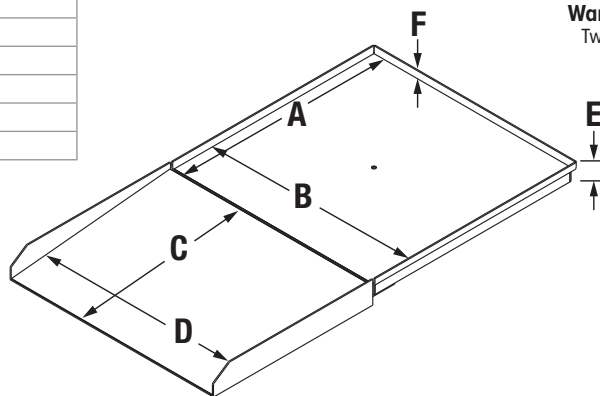

Specifications

Capacity:

1,000 × 0.2 lb (450 × 0.1 kg)

Platform Dimensions:

(L × W × H)

36.0 × 36.0 × 4.0 in

Ramp Dimensions:

(L × W × H)

36.0 × 28.5 × 4.0 in

Power:

9 VDC, provided by six AA alkaline batteries (included) or AC adapter (optional)

Battery Type:

Six AA alkaline (included)

Battery Use:

25 hours continuous use with batteries
Automatic power-off can be configured

Cable Length:

10 ft (3.1 m) cable between scale base and indicator

Display:

Five-digit LCD display, 0.75 in (1.9 cm) digit height

Temperature:

Operating:
50 °F to 104 °F (10 °C to 40 °C)

Warranty:

Two-year limited

SD-1150-WP

Dialysis Wheelchair Scale

Wall mounted indicator, cable enclosed in customer supplied conduit.



Standard Features

- Package includes scale, pit frame, handrail and indicator
- Large LCD display
- Antimicrobial keypad
- Heavy-duty mild steel construction
- Live handrail for accuracy and patient safety
- Unit of measure toggle or locking
- Motiontrap™ movement compensation technology
- EMR capable
- Serial and USB data communication ports
- Wireless personal area network (WPAN) option available
- Tare function
- Hold function
- Body mass index (BMI) function
- Factory calibrated

Specifications

Capacity:

1,000 × 0.2 lb (450 × 0.1 kg)

Platform Dimensions:

(L × W × H)

36.00 × 36.00 × 3.00 in

Power:

9 VDC, provided by six AA alkaline batteries (included) or AC adapter (optional)

Battery Type:

Six AA alkaline (included)

Battery Use:

25 hours of continuous use with batteries
Automatic power-off can be configured

Display:

Five-digit LCD display, 0.75 in (1.9 cm) digit height

Cable Length:

10 ft (3.1 m) cable between scale base and indicator

Temperature:

Operating:
50 °F to 104 °F (10 °C to 40 °C)

Warranty:

Two-year limited

Part Number/Price

Part #	Model #	Capacity	Price
150707	SD-1150-WP	1,000 × 0.2 lb (450 × 0.1 kg) with USB	\$3,245.00
205978	SD-1150-WPWPAN	1,000 × 0.2 lb (450 × 0.1 kg) WPAN	\$3,550.00

Shipping Weight

Part #	Model #	L × W × H	Package Wgt. (lb)	Dim Wgt. (lb)	Shipping Wgt. (lb)
150707	SD-1150-WP	40 × 39 × 15 in	246	169	246
205978	SD-1150-WPWPAN	40 × 39 × 15 in	246	169	246

Options/Accessories

Part #	Description	Price
133077 †	9VDC adapter, 100-240V, NEMA 1-15 Plug, cULus power supply	\$30.00



† NEMA 1-15 Plug

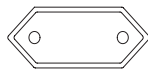

†† CEE 7/16 Plug

Dimensions

	Inches	Centimeters
A	36.00	91.4
B	36.00	91.4
C	3.00	7.6
D	28.50	72.4
E	31.50	80.0
F	37.00	94.0
G	35.50	90.2

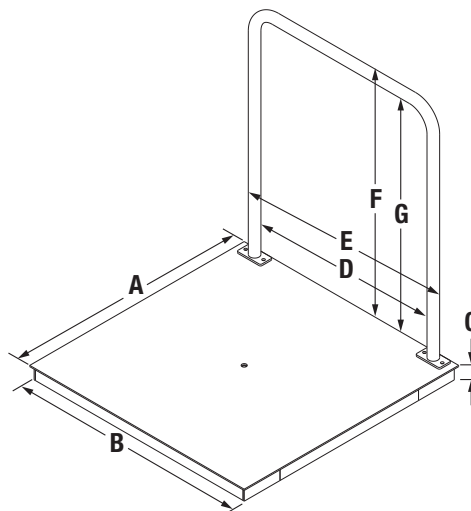

SD-1150-WP

Pit Frame Concrete Details

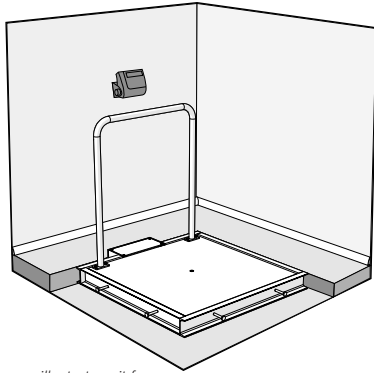
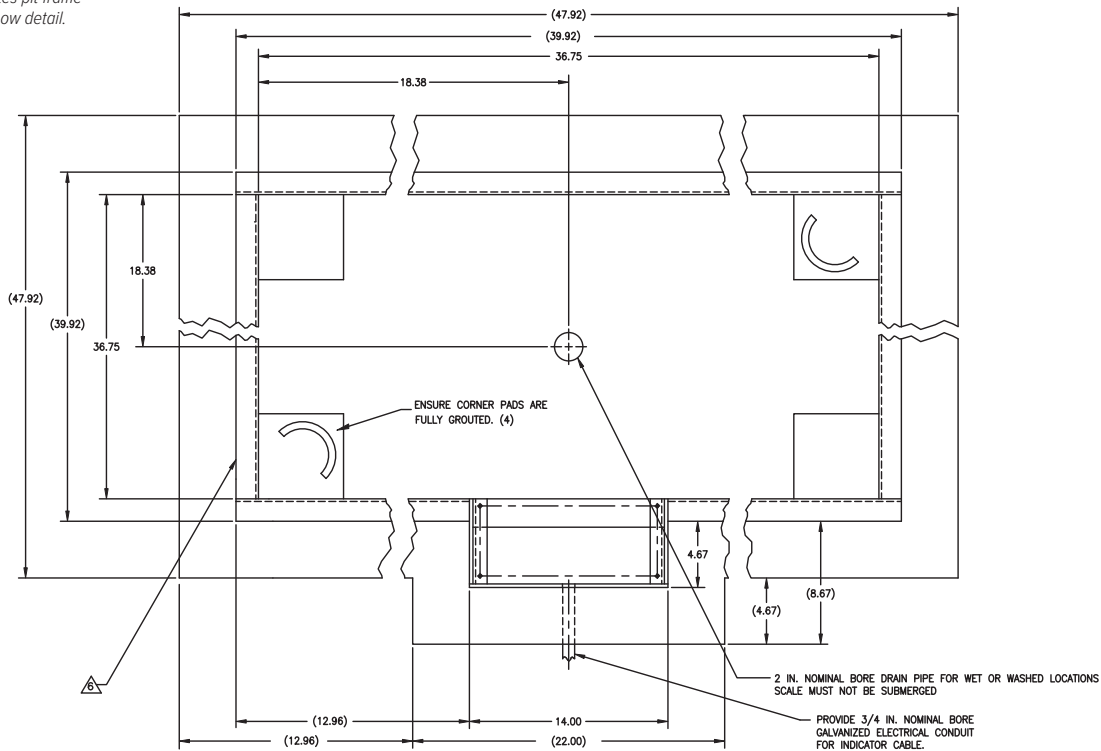
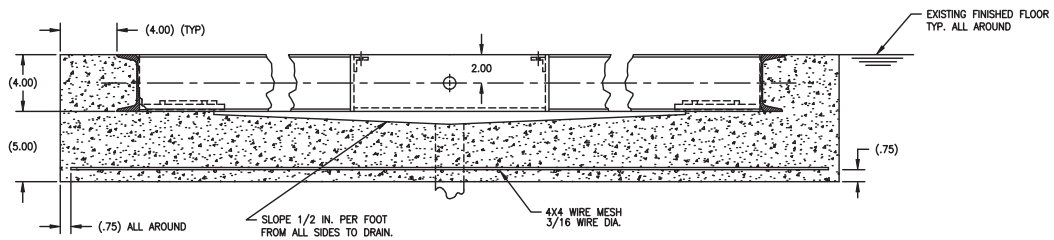

Image illustrates pit frame exposed to show detail.

Drawing dimensions shown in inches



NOTE: HANDRAIL ON SCALE WILL MOUNT ON SAME SIDE AS JUNCTION BOX POCKET



NOTE:

1. USE CONCRETE OF MINIMUM YIELD STRENGTH 5000 PSI OR 6-BAG MIX.
 2. ALLOW 7 DAYS TO CURE. WET CONCRETE PERIODICALLY DURING THIS TIME.
 3. DIMENSIONS SHOWN ASSUME FIRM, STABLE SOIL CONDITIONS. WHEN SOIL CONDITIONS ARE NOT ADEQUATE, PLACE FOUNDATION AT SUFFICIENT DEPTH.
 4. IN WET OR WASHDOWN APPLICATIONS WE RECOMMEND THE USE OF HERMETICALLY SEALED LOAD CELLS, AND THAT THE JUNCTION BOX BE MOUNTED REMOTELY IN A DRY LOCATION.
 5. WIRE MESH TO HAVE MINIMUM .75 COVER BOTTOM AND SIDES.
- △ ON STAINLESS STEEL VERSIONS, TWO PIECES OF 2 INCH ANGLE WILL BE SUBSTITUTED FOR THE 4 INCH CHANNEL.

350-10-8S

Digital Stretcher Scale

HEALTH SCALES

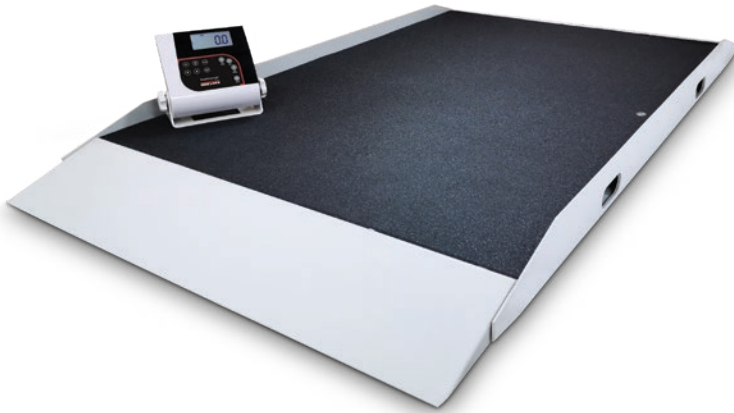

Standard Features

- Large LCD display
- Antimicrobial keypad
- Two wheels for easy transport
- Dual ramp
- Metal, nonslip platform
- Safety side rails
- Motiontrap™ movement compensation technology
- Unit of measure toggle or locking
- EMR capable
- Serial and USB data communication ports
- Wireless personal area network (WPAN) option available
- Tare function
- Hold function
- Body mass index (BMI) function
- Factory calibrated

Specifications

Capacity:

1,000 × 0.2 lb (450 × 0.1 kg)

Platform Dimensions Without Ramps:

(L × W × H)
49.30 × 32.70 × 2.60 in

Platform Dimensions with Wheels and Ramps:

(L × W × H)
63.80 × 32.70 × 2.60 in

Power:

9 VDC, provided by six AA alkaline batteries (included) or AC adapter (optional)

Battery Type:

Six AA alkaline (included)

Battery Use:

25 hours continuous use with batteries
Automatic power-off can be configured

Display:

Five-digit LCD display, 0.75 in (1.9 cm) digit height

Temperature:

Operating:
50 °F to 104 °F (10 °C to 40 °C)

Cable Length:

7 ft (2.1 m) cable between scale base and indicator

Warranty:

Two-year limited

Part Number/Price

Part #	Model #	Capacity	Price
203622	350-10-8S	1,000 × 0.2 lb (450 × 0.1 kg) with USB	\$3,350.00
203623	350-10-8SWPAN	1,000 × 0.2 lb (450 × 0.1 kg) WPAN	\$3,650.00

Shipping Weight

Part #	Model #	L × W × H	Package Wgt. (lb)	Dim Wgt. (lb)	Shipping Wgt. (lb)
203622	350-10-8S	67.2 × 36 × 6 in	154	104	154
203623	350-10-8SWPAN	67.2 × 36 × 6 in	154	104	154

Options/Accessories

Part #	Description	Price
133077 †	9VDC adapter, 100-240V, NEMA 1-15 Plug, cULus power supply	\$30.00



† NEMA 1-15 Plug

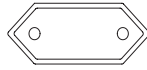

†† CEE 7/16 Plug

Dimensions

	Inches	Centimeters
A	63.80	162.1
B	49.30	125.3
C	32.70	83.1
D	32.90	83.6
E	3.90	9.9
F	2.60	6.7
G	0.55	1.4

