

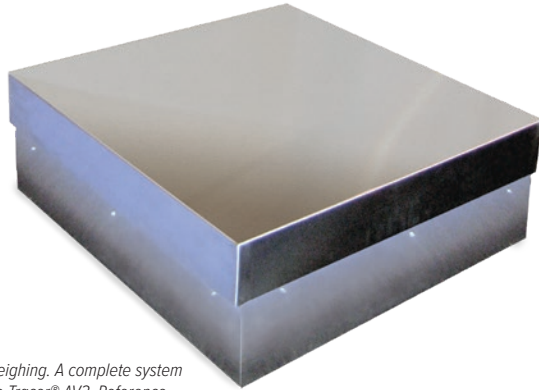

BenchMark® HD-2

Aviation Scale

BENCH SCALES



 Ideal for aviation weighing. A complete system can be sold with the Tracer® AV2. Reference Aviation section for specifications.

Approvals



Measurement
Canada
Approved



Part Number/Price

Part #	Capacity	Platform Dimensions	Price
Consult	500 lb (225 kg)	W × D × 12 in	Consult

Note: Maximum size is up to 36 in × 36 in, height is always 12 in W × D supplied by customer.

Standard Features

- Heavy-duty scale designed mild steel base construction with 304 stainless steel cover
- Polyurethane rubber leveling feet with stainless steel stems
- Load cell comes standard with DB-9 connector for connecting to Tracer AV2
- Three-sided kick plate

Specifications

Load Cell:

IP67, environmentally sealed
Aluminum

Output Impedance:

350 ohm

Maximum Overload:

200%

Overload Protection:

Five-point, independently adjusted

Cable Length:

10 ft (3 m)

Temperature:

Compensated:
14 °F to 104 °F (-10 °C to 40 °C)

Warranty:

Two-year limited

Approvals:

NTEP 06-010, Class III 5,000 d
Measurement Canada AM-5625
Load cell is cFMus approved

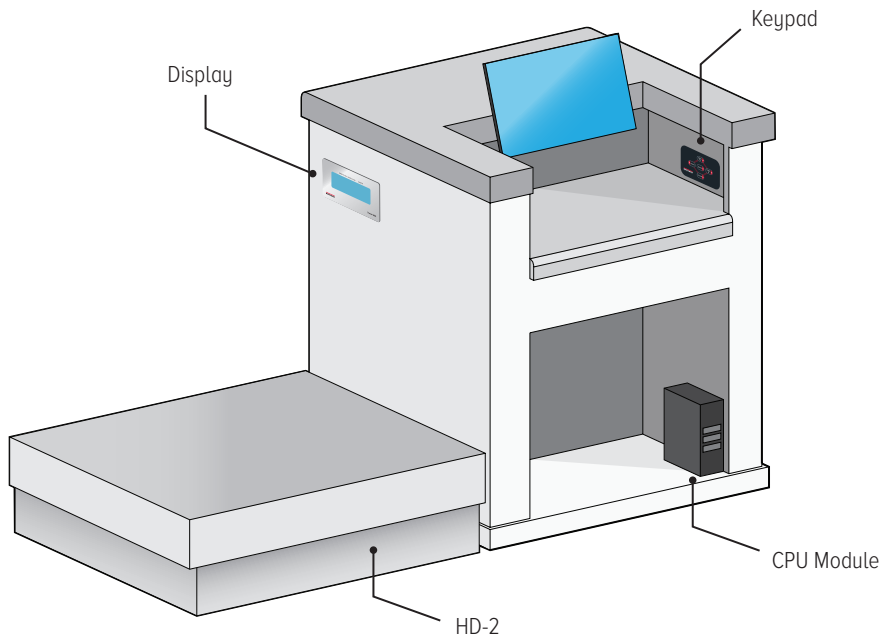

Baggage weighing system with Benchmark HD-2 and Tracer AV2 single LCD panel mount display, single keypad

BenchMark® HD-2

Aviation Scale

BENCH SCALES

