

Load Cell and Weigh Module

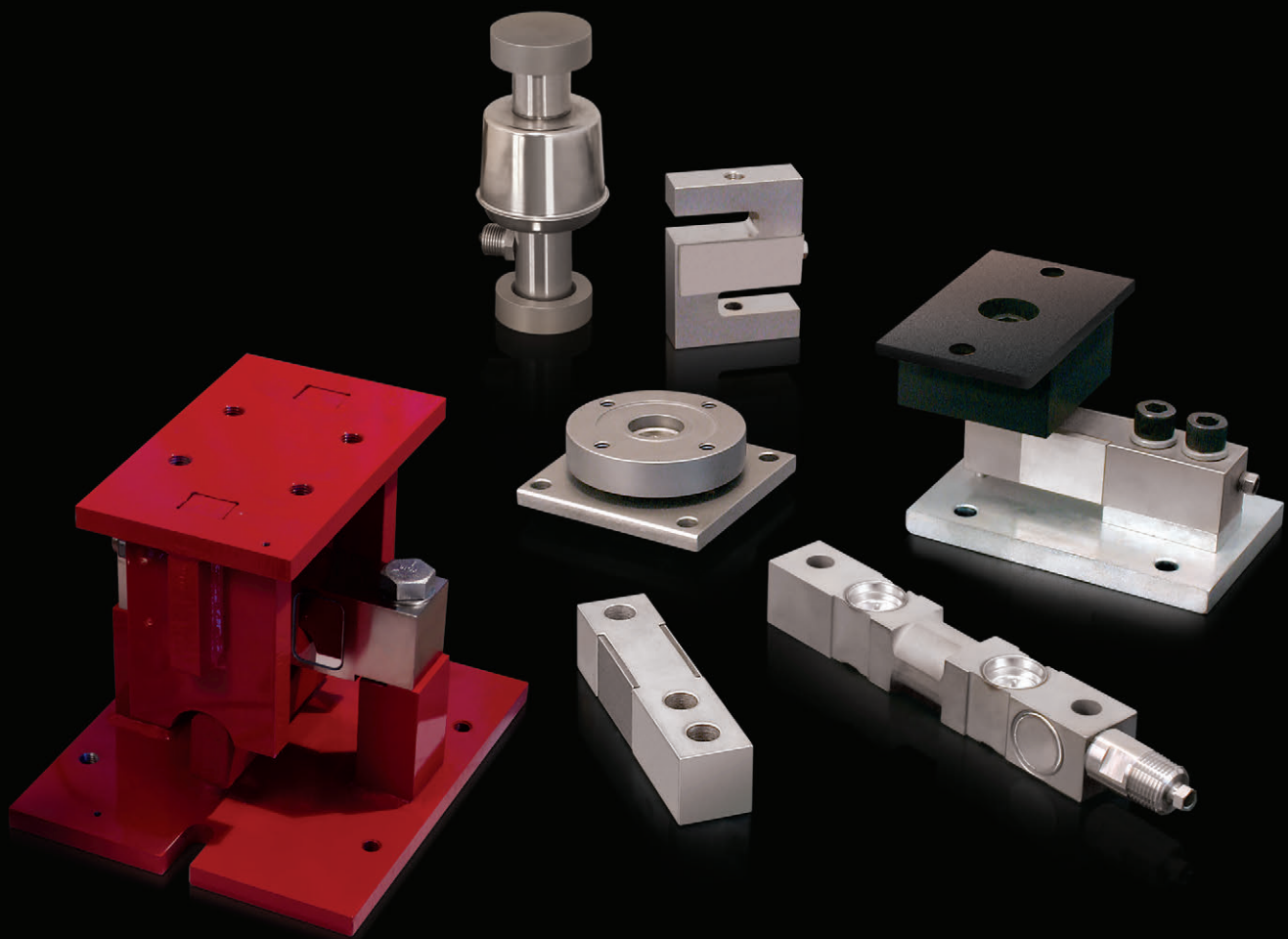

RICE LAKE[®]
WEIGHING SYSTEMS

www.ricelake.com

800-472-6703

© Rice Lake Weighing Systems. All rights reserved.

Rice Lake Weighing Systems® is a registered trademark of
Rice Lake Weighing Systems.

All other brand or product names within this publication are trademarks or
registered trademarks of their respective companies.

All information contained within this publication is, to the best of our knowledge, complete and
accurate at the time of publication. Rice Lake Weighing Systems reserves the right to make
changes to the technology, features, specifications and design of the equipment without notice.

The most current version of this publication, software, firmware and all other product
updates can be found on our website:

www.ricelake.com

Contents

Introduction to Load Cells	1
1.0 Load Cell Types	2
2.0 Load Cell Construction	6
3.0 Selecting Load Cells	7
4.0 Load Introduction Principles	11
5.0 DC Circuit Theory	14
6.0 Load Cell Electrical Theory	18
7.0 Rice Lake Weighing Systems Calibration Certificate	22
Weigh Modules	24
8.0 Weigh Modules: Single-Ended Beam	25
9.0 Weigh Modules: Double-Ended Beam	32
10.0 Weigh Modules: Compression Canisters	38
11.0 Weigh Modules: Tension Mounting (S-Beam)	40
Vessel Weighing System Design	45
12.0 Bulk Material Weighing Systems	46
13.0 Maximizing System Accuracy	52
14.0 Selecting the Number of Supports and Load Cell Capacity	54
15.0 Calculating Thermal Expansion of Vessels and Stay Rods	55
16.0 Calculating Tank Volumes	57
17.0 Wind and Seismic Effects on Vessel Stability	65
Vessel Attachments	71
18.0 Attaching Piping to Weigh Vessels	72
19.0 Piping Guidelines	77
20.0 Vessel Restraint Systems	80
Installation and Service Tips	83
21.0 Determining Microvolts per Graduation	84
22.0 Load Cell Mounting Hardware Safety Guidelines	85
23.0 Load Cell Trimming	87
24.0 Load Cell Troubleshooting	91
25.0 Calibration Guidelines for Vessel Weighing Systems	94
Appendix	97
26.0 Units of Measure	98
27.0 Glossary	99



Technical training seminars are available through Rice Lake Weighing Systems. Course descriptions and dates can be viewed at www.ricelake.com/training or obtained by calling 715-234-9171 and asking for the training department.

This Page Intentionally Blank.



Rice Lake continually offers web-based video training on a growing selection of product-related topics at no cost. Visit www.ricelake.com/webinars

Introduction to Load Cells

1.0	Load Cell Types	2
1.1	Canister	2
1.2	Single-Ended Shear Beam	2
1.3	Double-Ended Shear Beam	3
1.4	Cantilever Beam	4
1.5	S-Beam	4
1.6	Platform	5
2.0	Load Cell Construction	6
2.1	Materials	6
2.1.1	Aluminum Load Cells	6
2.1.2	Alloy Steel Load Cells	6
2.1.3	Stainless Steel Load Cells	6
3.0	Selecting Load Cells	7
3.1	Environmentally Protected	7
3.2	Welded Seal	7
3.3	Hermetically Sealed	8
3.4	Enclosure Protection Ratings	9
3.5	Painted	10
3.6	Lightning Protection	10
4.0	Load Introduction Principles	11
4.1	Ideal Loading	11
4.2	Angular Loading	11
4.3	Eccentric Loading	12
4.4	Side Loading	12
4.5	Twisting Loads	13
5.0	DC Circuit Theory	14
5.1	Electron	14
5.2	Current and Voltage	14
5.3	Resistance	14
5.4	Conductor Size	14
5.5	Strain Gauge	15
5.6	Wheatstone Bridge	15
5.7	Load Cell	16
6.0	Load Cell Electrical Theory	18
6.1	Wiring	18
6.2	Calibration Data	18
6.3	Output	19
7.0	Rice Lake Weighing Systems Calibration Certificate	22

1.0 Load Cell Types

Load cells are built in various sizes and types for many applications. This section reviews the different load cells available.

1.1 Canister

The canister load cell is the earliest design. It is hermetically sealed or welded to protect the gauges. See [Figure 1-1](#).

Canister load cell popularity has decreased due to the cost being two to three times more than beam load cells. Canister load cells are constructed in two ways, single-column and multiple-column. Single-column canisters cannot normally withstand a side load of over 15%. Multiple-column canisters withstand more side load than the single-column. The canister load cell ranges in size from 100 to 500,000 lb. There is no way to identify which load cells are single or multiple-column based on labeling or visual inspection. Refer to original manufacturer's specifications or Rice Lake Weighing Systems' Load Cell Guide to determine a load cell's specifications.

Canister cells are made of stainless steel or high alloy steel with a protective coating. Their rated excitation ranges from 5 VDC to 15 VDC. Common bridge resistances are 350 Ω and 480 Ω .

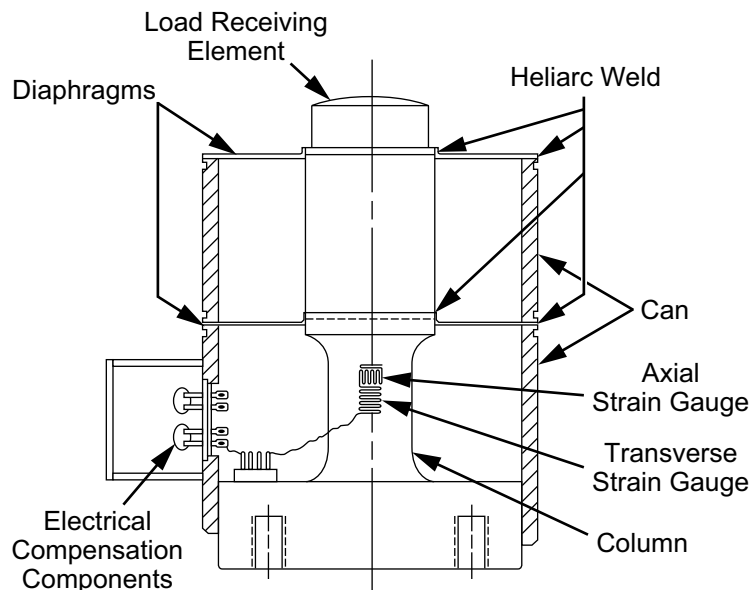

Figure 1-1. Canister Load Cell

1.2 Single-Ended Shear Beam

The single-ended shear beam load cell is designed for low-profile scale and process applications. The load cell strain gauge cavity contains a thin metal diaphragm onto which the strain gauges are mounted.

Typical capacities range from 1,000 to 20,000 lb, but some manufacturers offer shear beams up to 40,000 lb.

One end of the shear beam contains the mounting holes, while the opposite end is where the load is applied.

The load cell should be mounted on a flat, smooth surface with high-strength hardened bolts.

The larger shear beam load cells have more than two mounting holes to accommodate extra bolts and keep the hardware from stretching under stress load. See [Figure 1-2 on page 3](#).

Shear beams operate best in a temperature range of 14 to 104°F (-10 to 40°C). Their maximum safe operating range with minimum performance change is from 0 to 150°F (-17 to 65°C). Shear beam zero outputs should be frequently checked when operating at high temperatures. Overloads in excess of the safe overload rating may permanently affect the accuracy and performance of the load cell. Shock loads, especially repeated or overrated capacity, affect the calibration and should be avoided.

Shear beams may be constructed of alloy steel or stainless steel for use in harsh environments. Just because a cell is made of stainless steel does not mean it is the best choice in wash down environments. Appropriate sealing is also important.

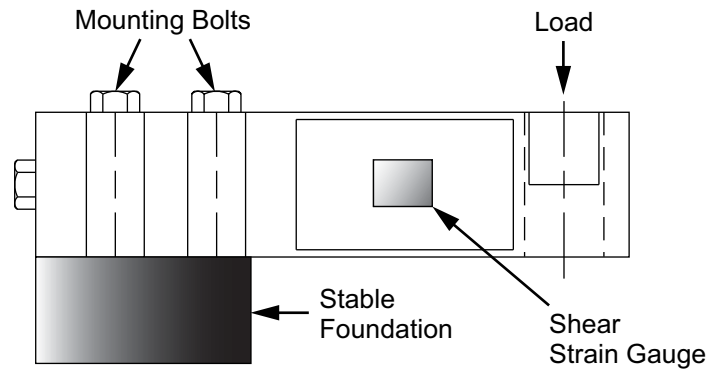

Figure 1-2. Single-Ended Shear Beam

1.3 Double-Ended Shear Beam

The double-ended shear beam characteristics are similar to those of the single-ended shear beam. The most common bridge resistance for this type of load cell is 700 Ω . The double-ended shear beam is most commonly used in truck scales. Instead of being secured at one end with the load applied to the other end, as in the single-ended shear beam, the double-ended shear beam is secured at both ends with the load applied to the center of the load cell. As in all shear beam designs, the strain gauges are mounted on a thin web in the center of the load cell's machined cavity. There are various methods to protect the strain gauges on double-ended shear beam load cells: neoprene rubber with metal clamp, metal covers with epoxy sealant or welded covers. All are application specific.

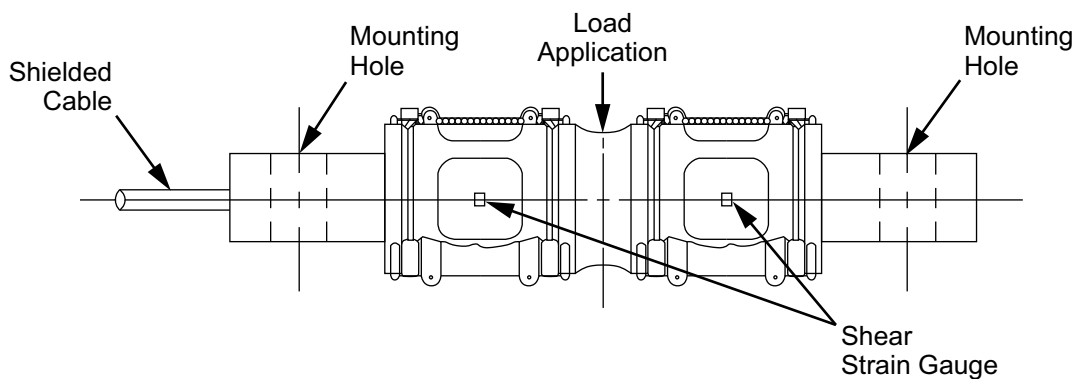

Figure 1-3. Double-Ended Shear Beam

1.4 Cantilever Beam

Cantilever beams, also called bending beams, are similar to shear beams. However, the cantilever beam does not have a thin web located in the strain gauge cavity. The cantilever beam is machined all the way through. The strain gauges are mounted along the inner edges of the cavity. Most cantilever beams have a bridge resistance of 350 Ω and either 3 mV/V or 2 mV/V full scale outputs. They range from capacities of 25 up to 10,000 lb. However, there may be a few larger cantilever beams being used up to 20,000 lb. They can be used in tension or compression applications.

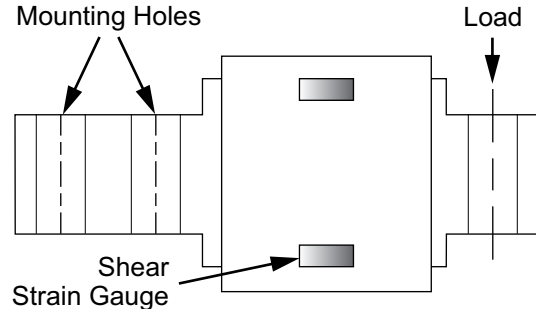

Figure 1-4. Cantilever Beam

1.5 S-Beam

S-beam load cells get their name from their shape, which is the shape of the letter S. The S-beam is normally used in tension applications, however, there are S-beams available which are bidirectional. They are primarily used for mechanical-to-electronic scale conversions, platform scales and general purpose weighing applications. They vary in size from as low as 25 lb to as high as 20,000 lb. When mounting an S-beam, remember that the side from which the cable extends is the dead portion of the system. Movement of the cable in the live part of the system can be a source of weighing errors. To minimize the twisting on an S-beam load cell, a swivel at the top and/or bottom of the load cell can be used.

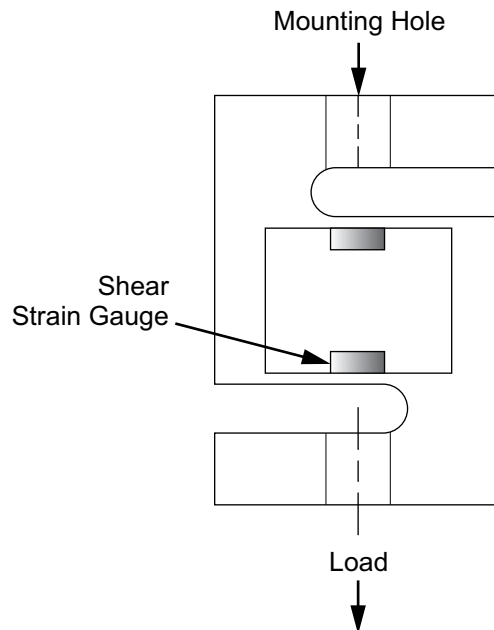

Figure 1-5. S-Beam

1.6 Platform

The platform load cell is also referred to as a dual-guided cantilever beam load cell or a single point load cell. They are used in light capacity bench scales and are often made of aluminum. Common sizes are 2 to 1,000 lb with a bridge resistance of 350 Ω .

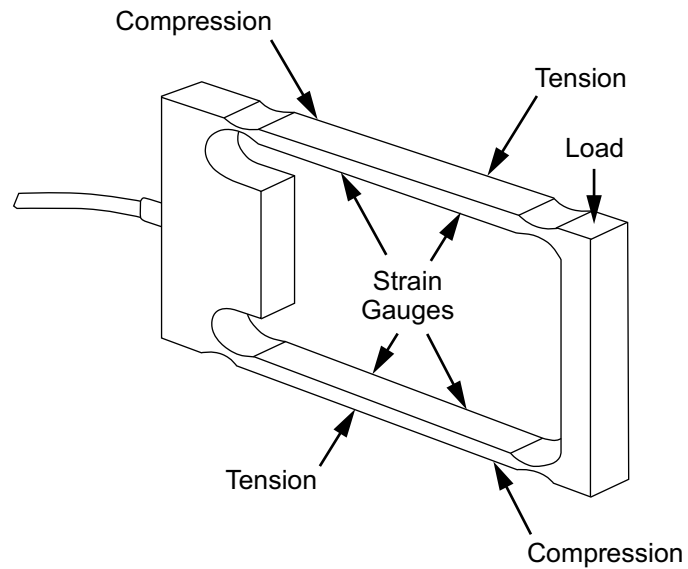

Figure 1-6. Platform Load Cell

2.0 Load Cell Construction

Load cells can be constructed from a variety of materials.

2.1 Materials

2.1.1 Aluminum Load Cells

Aluminum load cell elements are used primarily in single point, low capacity applications. The alloy of choice is 2023 because of its low creep and hysteresis characteristics. Aluminum load cells have relatively thick web sections compared to alloy steel cells of comparable capacities. This is necessary to provide the proper amount of deflection in the element at capacity. Machining costs are usually lower on aluminum elements due to the softness of the material.

2.1.2 Alloy Steel Load Cells

Load cells manufactured from alloy steel are by far the most popular cells in use today. The cost to performance ratio is better for alloy steel compared to either aluminum or stainless steel designs. The most popular alloys are 4330 or 4340 because they have low creep and low hysteresis characteristics. This type of steel can be manufactured to spec consistently, which means load cell design changes don't have to be made every time a new lot or new steel vendor is selected.

2.1.3 Stainless Steel Load Cells

Stainless steel load cells are made from 17-4ph or comparable stainless alloy, which is the alloy having the best overall performance qualities of any of the stainless derivatives. Stainless steel cells are more expensive than alloy steel load cells. They are sometimes fitted with hermetically sealed web cavities which makes them an ideal choice for high moisture applications. Stainless steel load cells that are not hermetically sealed have little advantage over comparable cells constructed of alloy steel, other than a higher resistance to corrosion.

3.0 Selecting Load Cells

Using load cells incorrectly can create safety problems and be expensive. Load cells are categorized in three major groups:

- Environmentally Protected (EP)
- Welded Seal (WS)
- Hermetically Sealed (HS)

Hermetically sealed cells are also characterized by the Ingress Protection (IP) numbers. This system effectively matches load cell to application for optimal results.

To select the proper load cell protection qualities, a fundamental understanding of the differences between environmentally protected and hermetically sealed load cells is necessary. The inappropriate use of environmentally protected load cells in harsh conditions is a prescription for load cell failure. Because of the extra manufacturing steps, hermetically sealed load cells cost more than environmentally protected versions and are more suitable for harsh conditions. Despite the higher initial cost, hermetically sealed load cells may be the best long-term choice for washdown and unprotected outdoor applications.

3.1 Environmentally Protected

Environmentally protected load cells are designed for normal environments in indoor or protected outdoor weighing applications. These load cells may employ strategies like potting, rubber booting or redundant sealing to offer some protection from moisture.

Potted load cells utilize one of several types of industrial potting materials. The liquid potting material fills the strain gauge cavity then gels, completely covering the strain gauge and wiring surfaces. While this may significantly diminish the chance of moisture contamination, it does not guarantee extended protection, nor does it withstand corrosive attack. A second method of protection uses an adhesive foam-backed plate. This protection affords some moisture and foreign object protection. In many cases, manufacturers will use a caulking material to seal the plate to decrease the potential for cavity contamination. A common approach among manufacturers to further decrease the entry of moisture to the strain gauge combines both a potted cavity and a foam-backed plate, in a process called redundant sealing.

Another strain gauge cavity protection strategy is the rubber boot. Commonly employed with cantilever and bending beam models, the boot covers the cavity and is secured by clamps. While this provides easy access for repairs, the boot may crack if not lubricated regularly, allowing contaminants into the load cell cavity. Lubricating the rubber boot during routine inspections will contribute to the long-term durability of the load cell.

Protecting the strain gauge cavity is just one consideration in protecting a load cell from contamination. Another susceptible area is the cable entry into the body of the load cell. Most environmentally protected load cells incorporate an O-ring and cable compression fitting to seal the entry area. This design provides protection only in applications with minimal moisture. In high-moisture areas, it is safest to install all cabling in conduit, providing both a moisture barrier and mechanical protection.

3.2 Welded Seal

Welded seal load cells are environmentally protected, with the addition of welded gauge covers. Although environmentally protected and welded seal load cells keep out unwanted contaminants, they are not suited for high moisture, steam, or direct washdown applications. The only long-term strategy for these applications is to use true hermetically sealed load cells.

3.3 Hermetically Sealed

Hermetically sealed load cells offer the best protection available for the weighing market. Using advanced welding techniques and ultra-thin metal seals, these load cells handle the extremes of harsh chemical and washdown applications. What makes the seal unique is the process of laser-welding metal covers to protect the strain gauge and compensation chambers. The cavities are then injected with potting or, in the case of glass-to-metal seals, filled with a pressurized inert gas, providing a redundant seal. As a final assurance of the integrity of the seal, a leak test is conducted to reveal any microscopic flaws in the sealing weld.

True hermetic protection addresses both the strain gauge cavity and cable entry area. The most advanced cable entry design employs a unique glass-to-metal bonding seal which makes the cable termination area impervious to moisture. Cable wires terminate at the point of connection to the load cell, where they are soldered to hermetically sealed pins that carry signals to the sealed strain gauge area through a glass-to-metal seal. Water or other contaminants cannot “wick up” into the load cell, since the cable ends at the entry point. This design allows for field-replaceable cable, since the connection is outside the load cell.

Stainless steel load cells are not synonymous with hermetically sealed load cells. While environmentally-protected stainless steel load cells may be suitable for dry chemical corrosive environments, hermetically sealed stainless steel models are the appropriate choice for high-moisture or washdown applications.

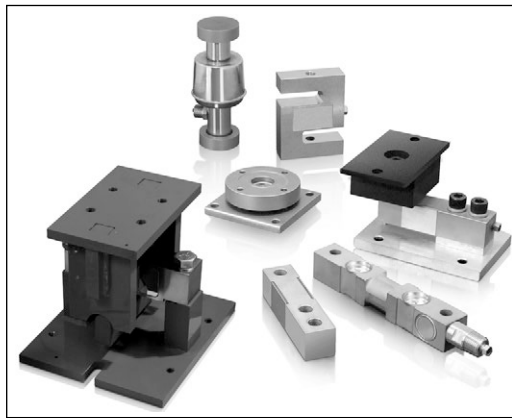

Figure 3-1. Load Cells

3.4 Enclosure Protection Ratings

The International Electrotechnical Commission (IEC) developed ingress protection (IP) ratings to grade an enclosure's resistance to dust or liquid intrusion, as well as the ease with which individuals can access potentially hazardous parts within the enclosure.

IEC 60529 guidelines were developed to rate the resistance of electric and electronic device enclosures, specifically, against the intrusion of solid objects, dust and liquids. Varying degrees of protection are represented by a numeric system known as IP ratings.

This system follows the format IP## where ## is a combination of numerals (see [Table 1-1](#)). The first digit following IP identifies the level of protection against solid objects, including dust. The second digit is the level of protection against various forms of moisture.

IP	6	9
Ingress Protection	First digit: Protection against solids	Second digit: Protection against moisture

Table 1-1. IP Rating Format

[Table 1-2](#) lists common IP ratings, from the highest level of ingress protection to the lowest, describing the protection provided.

IP Rating	Description
IP69K	Dust-tight and withstands high-pressure, high-temperature water NOTE: K designates resistance to high-pressure water.
IP68	Dust-tight and protects against continuous immersion in water
IP67	Dust-tight and protects against temporary immersion in water
IP66	Dust-tight and protects against high-pressure water projected from any direction
IP65	Dust-tight and protects against low-pressure water projected from any direction
IP64	Dust-tight and protects against splashed water
IP54	Dust protected and protects against splashed water

Table 1-2. IP Rating Descriptions

3.5 Painted

Painted (P) load cells are the optimum choice for harsh chemical applications. These load cells are protected against the harmful affects of many chemicals because of the paint applied during manufacturing.

3.6 Lightning Protection

Load cells with Lightning Protection (LP) are designed for applications that could see excessive voltage. No electronic device is designed to withstand a direct lightning strike, however, with single-point grounding you can protect your scale in case of an indirect voltage surge. Due to the advantages that single-point grounding provides, it is required on all Rice Lake systems. Reference Rice Lake's webinars for more details.

LP load cells are recommended for outdoor applications, especially truck scales. These load cells are designed with built-in lightning protection to withstand several voltage surges without damaging the load cells critical electronics. In most load cells, a voltage surge would immediately damage the load cell's strain gauges which are the most susceptible. Rice Lake's LP load cells offer two layers of protection to the bridge's electrical circuit.

- Thermistors (overcurrent protection) provide protection against the temperature increase during a voltage surge.
- A gas discharge tube provides transient voltage suppression by directing large transient currents directly to the ground protecting the load cells wheatstone bridge.

4.0 Load Introduction Principles

A clear understanding of the exact manner of how a load is introduced to a load cell will assist in both designing a vessel that is to be equipped with load cells, and in choosing the correct type of load cells and mounts for the intended application.

4.1 Ideal Loading

Load cell specifications are derived under laboratory conditions, where load is applied to the cell under near-perfect conditions. The performance of load cells in an actual process weighing application can be greatly degraded if care is not taken in the means by which the load is applied to the cell.

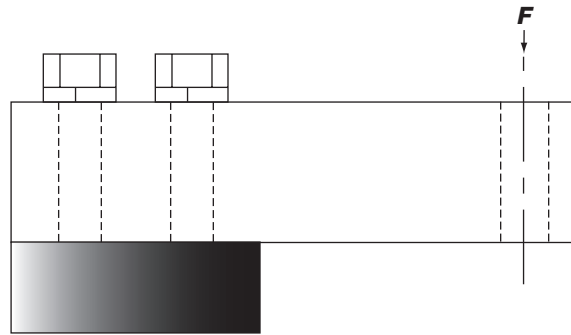

Figure 4-1. Ideal Loading

Figure 4-1 shows a typical mounting arrangement for a single-ended beam. The fixed end is fastened to a rigid foundation, while the free end is cantilevered to allow downward deflection as load (F) is applied. Under ideal conditions, the mounting surface would be flat, horizontal and perfectly rigid. The load F would be introduced vertically with minimal extraneous forces applied, and the load cell would be totally insensitive to all forces other than precisely vertical ones.

However, in the real world, load cell mounting and loading conditions are far from ideal. Incorrect loading is by far the most common cause of accuracy problems encountered by service technicians. Understanding the following common load introduction problems will prevent loading errors in the vessel weighing application.

Though the discussion is confined to single-ended beams, many of the principles apply equally to other load cell types.

4.2 Angular Loading

This is a condition where the load F is introduced through the loading hole, but at an angle to its center line (see Figure 4-2). This angular force can be broken up into its vertical component along the loading hole center line, which the cell will register, and its horizontal component at 90° from the center line. This horizontal component is a side force to which, ideally, the load cell would be totally insensitive. For example, if force F is inclined to the load hole center line at an angle of 5° , then the force registered by the cell is reduced by 0.4% while a side force of $0.01F$ is also applied.

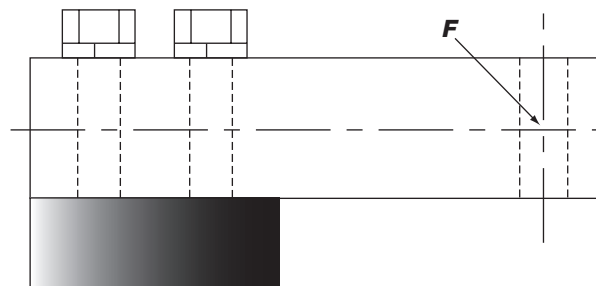

Figure 4-2. Angular Loading

If the direction of the force is constant, calibration will compensate for this and the scale will weigh accurately. However, if the angle changes as the force is applied, it will cause nonlinearity and if there is friction in the mechanical system, hysteresis will also be present. Angular loads can be caused by mounts that are out of level, a nonrigid foundation, thermal expansion/contraction, structure deflection under load, and the unavoidable deflection of the load cell itself.

4.3 Eccentric Loading

This is a condition where the load F is applied vertically to the cell, but its line of action is shifted away from the vertical line through the loading hole (see Figure 4-3). This is not a detrimental condition if the force is applied consistently at the same point, since calibration will compensate for this effect. However, if the point of application moves horizontally as the scale is loaded, it will cause nonlinearity and possibly hysteresis. Eccentric loads may be caused by poorly designed mounting arrangements, thermal expansion/contraction of the scale and damaged parts.

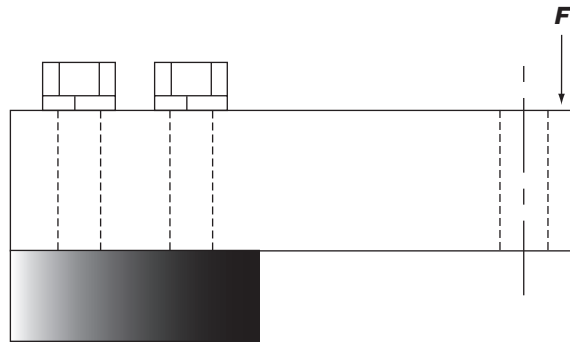

Figure 4-3. Eccentric Loading

4.4 Side Loading

This is a condition where the vertical load F (which is to be measured) is accompanied by a side force R applied at 90° to F (see Figure 4-4). This force can be constant, but more typically is a force that varies over time and hence affects the linearity and possibly the hysteresis of the scale. The ideal load cell would be totally insensitive to side loads. However, in practice these extraneous forces do affect the output of the cell and two seemingly identical cells can react differently to the same side load. A related condition is the end force, P , which is similar to a side force, except that it acts on the end face of the cell. Side forces are typically the result of thermal expansion/contraction, mounts which are not level, and vessel dynamics (caused by mixers, etc.).

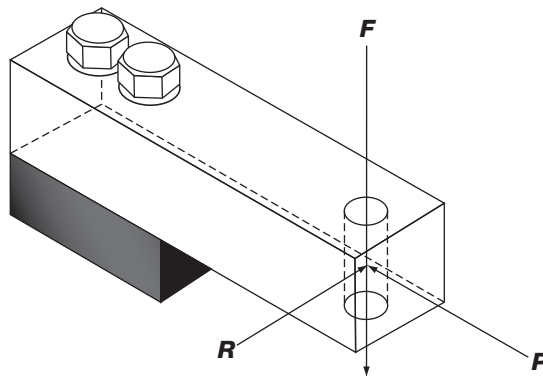

Figure 4-4. Side Loading

4.5 Twisting Loads

Typically, a side force does not act exactly at the neutral axis and hence produces a torque or twisting effect in addition to the side force. A load cell can be subjected to a torque (T) in a number of ways. [Figure 4-5\(a\)](#) illustrates a condition where the line of action of a side force is moved away from the neutral axis by a distance (h) resulting in a torque of Rh . [Figure 4-5\(b\)](#) illustrates a situation where the load is hung from the cell using a bolt. Any side force applied by this arrangement has a much larger twisting effect on the cell because of the increased distance (h_1) to the neutral axis.

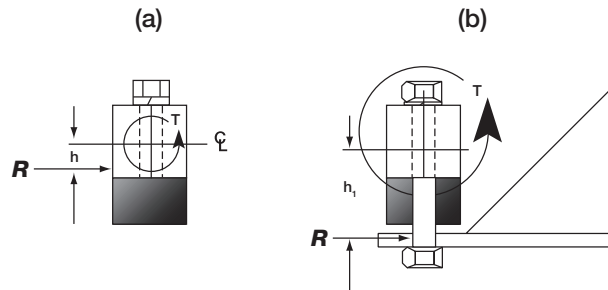

Figure 4-5. Twisting Loads

[Figure 4-6](#) illustrates a torque of magnitude (Fy) exerted as the result of the load (F) being applied at a distance (y) from the loading hole center line.

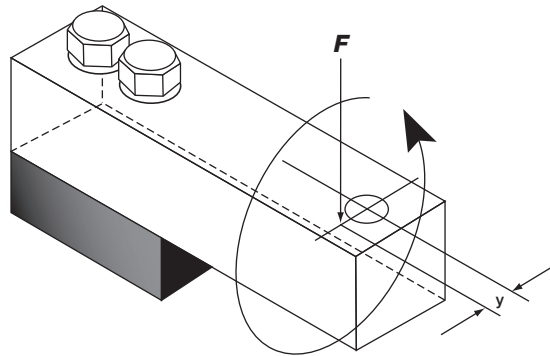

Figure 4-6. Twisting Loads

Mounts which are out of level as well as thermal expansion/contraction, structure deflection under load and dynamic side forces (caused by rotating mixers, etc.) all cause twisting of the load cell. Since these forces tend to vary in magnitude as a function of time, temperature and/or load, the effects are not predictable, and will degrade system accuracy.

5.0 DC Circuit Theory

5.1 Electron

An electron is a negatively charged particle that is a part of all atoms. Electrons found in orbits closer to the atom's center, or nucleus, are held into the atomic structure more closely than those electrons in the outermost orbit. Conductors such as gold, copper and silver have one electron in their outer orbit, also called the valence shell. These valence electrons can easily escape their atom and move randomly to another atom. These electrons are called free electrons. Free electrons bump into other valence electrons, causing more free electrons. Conductors have many free electrons randomly moving from atom to atom.

Insulators are opposite of conductors. Their valence shells contain many electrons which are tightly held to their atoms. Insulators have few free electrons and are very poor conductors of electricity.

5.2 Current and Voltage

Electrical current is the orderly flow of electrons. When electrons flow past a given point at the rate of 6.24×10^{18} electrons per second, one ampere (amp) of current is present. The name given to the number 6.24×10^{18} is a coulomb. So we can say one ampere of current is equal to one coulomb passing a given point in one second. The symbol used for amperes is A.

In order to move electrons in a conductor to produce current flow, a force must be exerted on the conductor. In electrical circuits this force is a difference in electrical potential between two points and is called voltage. So, current is the actual electron flow and the voltage is the force that causes the electrons to flow. The symbol used in electronics for current is I, and is measured in amperes (A). The symbol for voltage is E.

5.3 Resistance

Current flowing through a conductor encounters opposition from the conductor. This opposition to current flow is called resistance. The symbol used to denote resistance is R. The unit of measure for resistance is called the ohm (Ω).

5.4 Conductor Size

A conductor or wire has a certain amount of resistance depending on its diameter. The larger the diameter, the lower the resistance. If we stretch the wire we have decreased its diameter, or cross-sectional area, thus increasing its resistance. The opposite is also true. If we compress the wire, its diameter is increased and its resistance is decreased. Since it takes a force to act upon the wire to compress or stretch it, the wire can be configured to measure force. This configuration of wire is called a strain gauge.

5.5 Strain Gauge

A strain gauge consists of a very fine length of wire that is woven back and forth in a grid and laid on a flexible backing called the carrier. A common wire used is a copper-nickel alloy with a diameter of about one thousandth of an inch (0.001 in). The wire is zig-zagged to form a grid to increase the effective length of the wire that comes under the influence of the force applied to it. Leads are attached to the ends of the gauge. Strain gauges can be made very small, sometimes as small as 1/64 in. These gauges are adhesively bonded to a strong metal object, commonly referred to as the load receiving element, to make up a load cell. The type of metal used for a load receiving element must have optimum elasticity to return back to its original shape when the load is removed. The gauges are configured into a circuit called a Wheatstone bridge.

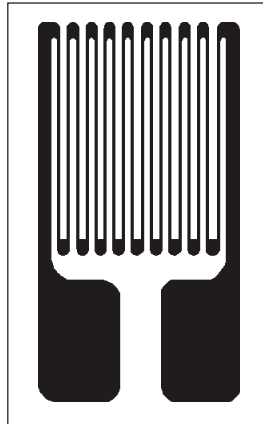
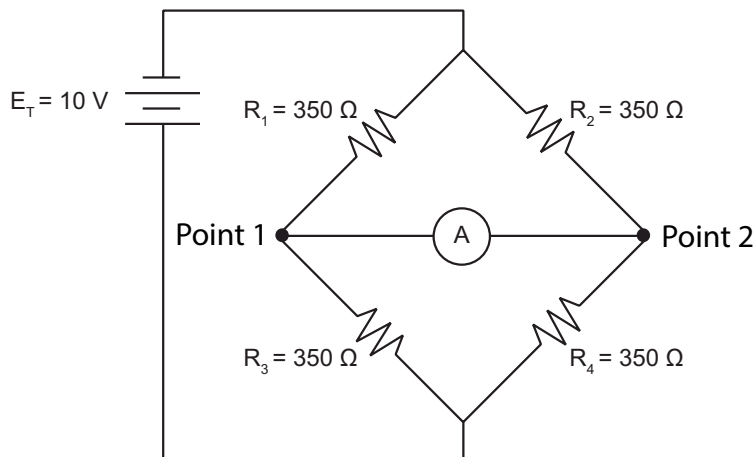

Figure 5-1. Strain Gauge

5.6 Wheatstone Bridge

The type of resistive circuit used in load cells is a Wheatstone bridge.



 **NOTE: All resistors are equal.**

 is a symbol for an ammeter, a device used to measure current flow and direction.

Figure 5-2. Balanced Wheatstone Bridge

When power is applied to this bridge the current flowing in the R_1 / R_3 branch is equal to the current flowing in the R_2 / R_4 branch. This is true because all resistors are equal. Since there is no voltage difference between points 1 and 2 there is no current flow through the ammeter. This bridge is in a balanced condition.

Now let's increase the resistance of R_1 and R_4 to 350.5 ohms, and decrease the resistance of R_2 and R_3 to 349.5 ohms.

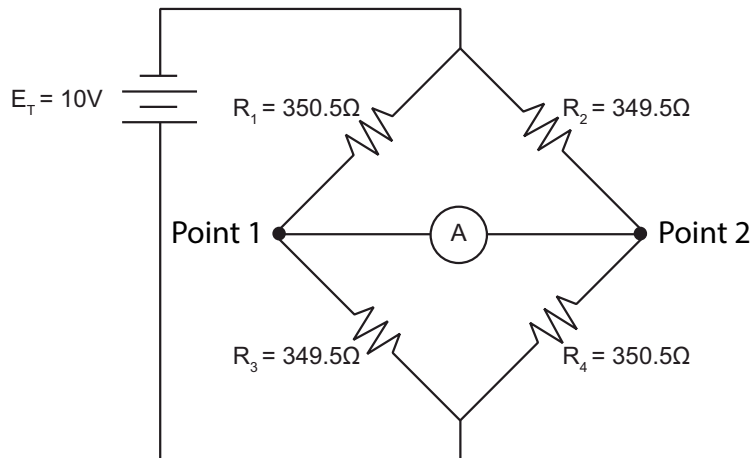

Figure 5-3. Unbalanced Wheatstone Bridge

Observe that the bridge becomes unbalanced. There are actually three paths for current flow in this circuit.

- Path 1 Negative battery terminal through R_2 and R_4 back to the positive battery terminal.
- Path 2 Negative battery terminal through R_1 and R_3 back to the positive battery terminal.
- Path 3 Negative battery terminal through R_2 , the ammeter, R_3 and back to the positive battery terminal.

Notice this time there is current flow through the ammeter. This current flow is a result of a potential difference between points 1 and 2. The larger the potential difference the larger the current flow through the ammeter.

5.7 Load Cell

We can take our strain gauge and Wheatstone bridge theories and use them to construct a load cell. We will use a column of steel and glue a strain gauge on each of the four sides of the column. As weight is placed on top of the column, the length of the column would decrease. The column also would become "fatter," or bulge out. Two strain gauges are placed opposite of each other to respond proportionately to the change in length.

Two other gauges are placed on opposite sides of the column and respond to the change in the column's bulge. Since one pair of strain gauges become shorter, their wire diameters become larger and their resistance decreases. The other pair of strain gauges are positioned so their wires lengthen, decreasing their diameter and increasing their resistance. If we hung the same weight from the bottom of the column instead of compressing the column, we would be placing tension on it. The column and strain gauges would act in the opposite direction but still stretch and compress the wires by the same amount. See [Figure 5-4](#).

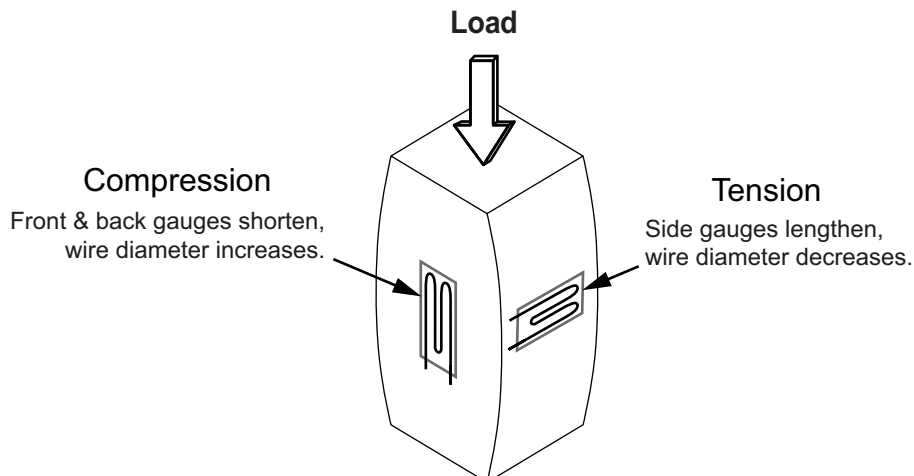

Figure 5-4. Strain Gauge

We can wire our strain gauges into a Wheatstone bridge configuration. We can calibrate the ammeter to read in pounds instead of amps. In effect we actually have a scale. Of course this is a crude, very inaccurate scale. It is intended to show the basic load cell principle. Load cells are made in different shapes and configurations. The strain gauges are strategically placed for peak performance. See [Figure 5-5](#).

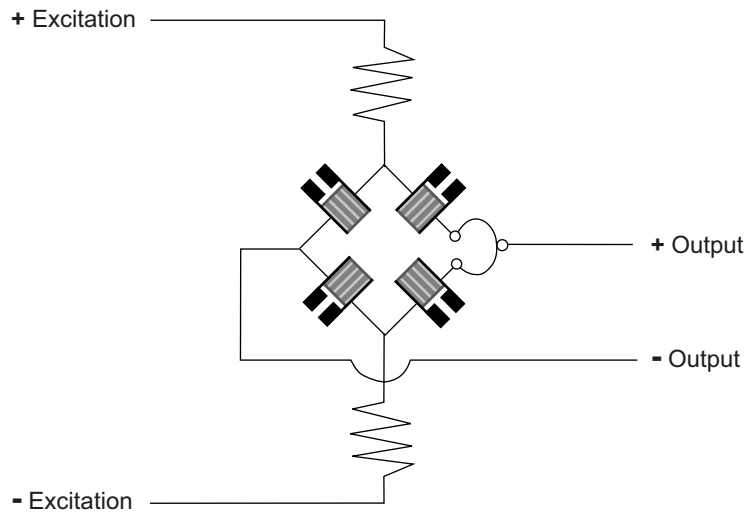

Figure 5-5. Load Cell

6.0 Load Cell Electrical Theory

6.1 Wiring

A load cell can have a cable with four or six wires. A six-wire load cell, besides having + and - signal and + and - excitation lines, also has + and - sense lines. These sense lines are connected to the sense connections of the indicator. These lines tell the indicator what the actual voltage is at the load cell. Sometimes there is a voltage drop between the indicator and load cell. The sense lines feed information back to the indicator. The indicator either adjusts its voltage to make up for the loss of voltage, or amplifies the return signal to compensate for the loss of power to the cell.

Load cell wires are color coded to help with proper connections. The load cell calibration data sheet for each load cell contains the color code information for that cell. Rice Lake Weighing Systems also provides a load cell wiring color guide on the back cover of the Load Cell Guide and a wire guide phone app at www.ricelake.com/wireapp.

6.2 Calibration Data

Most load cells are furnished with a calibration data sheet or calibration certificate. See [Section 7.0 on page 22](#) for an example of a calibration certificate. This sheet provides pertinent data about the load cell. The data sheet is matched to the load cell by model number, serial number and capacity. Other information found on a typical calibration data sheet is output expressed in mV/V, excitation voltage, non-linearity, hysteresis, zero balance, input resistance, output resistance, temperature effect on both the output and zero balance, insulation resistance and cable length. The wiring color code is also included on the calibration data sheet.

[Figure 6-1](#) illustrates a calibration curve and shows how many of the important load cell terms above relate to each other.

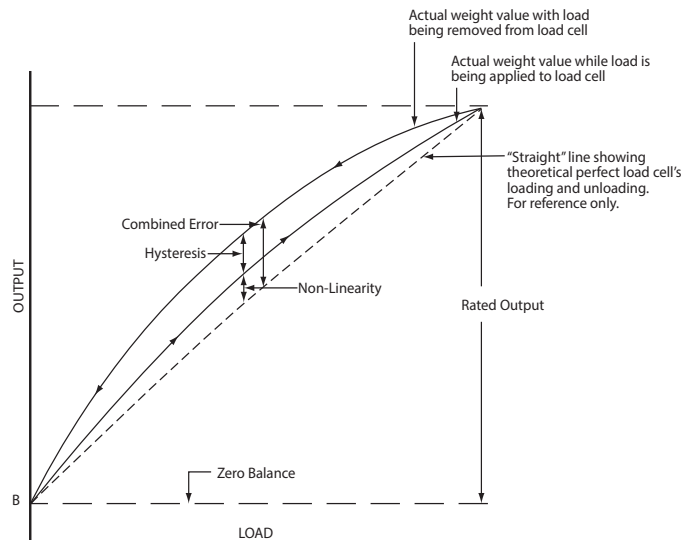

Figure 6-1. Calibration Curve

6.3 Output

A load cell's output is not only determined by the weight applied, but also by the strength of the excitation voltage, and its rated millivolts/volt (mV/V) full scale output sensitivity. For example, let's say that the full scale output for a load cell is 3 mV/V. This means that for each volt of excitation voltage applied at full scale, there will be 3 millivolts of signal output. If we have 100 lb applied to a 100 lb capacity load cell, with 10 volts excitation applied, the load cell signal strength will be 30 mV. That is $10 \text{ V} \times 3 \text{ mV/V} = 30 \text{ mV}$. Now let's apply only 50 lb to the cell, keeping our excitation voltage at 10 volts. Since 50 lb is 50% or one half of full load, the cell signal strength would be 15 mV.

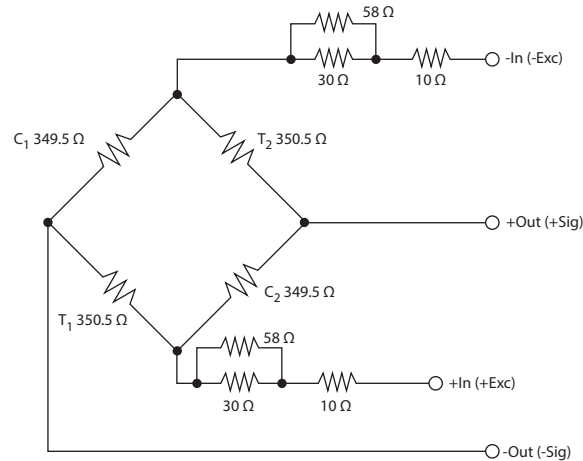

Figure 6-2. Wheatstone Bridge

The Wheatstone bridge shown in [Figure 6-2](#) is a simple diagram of a load cell. The resistors marked T_1 and T_2 represent strain gauges that are placed in tension when load is applied to the cell. The resistors marked C_1 and C_2 represent strain gauges which are placed in compression when load is applied.

The +In and -In leads are referred to as the +Excitation (+Exc) and -Excitation (-Exc) leads. The power is applied to the load cell from the weight indicator through these leads. The most common excitation voltages are 10 VDC, and 15 VDC depending on the indicator and load cells used. The +Out and -Out leads are referred to as the +Signal (+Sig) and -Signal (-Sig) leads. The signal obtained from the load cell is sent to the signal inputs of the weight indicator to be processed and represented as a weight value on the indicator's digital display.

As weight is applied to the load cell, gauges C_1 and C_2 compress. The gauge wire becomes shorter and its diameter increases. This decreases the resistances of C_1 and C_2 . Simultaneously, gauges T_1 and T_2 are stretched. This lengthens and decreases the diameter of T_1 and T_2 , increasing their resistances. These changes in resistance cause more current to flow through C_1 and C_2 and less current to flow through T_1 and T_2 . Now a potential difference is felt between the output or signal leads of the load cell.

Now trace the current flow through the load cell. Current is supplied by the indicator through the -In lead. Current flows from -In through C_1 and through -Out to the indicator. From the indicator current flows through the +Out lead, through C_2 and back to the indicator at +In. In order to have a complete circuit, we needed to get current from the -In side of the power source (Indicator) to the +In side and we accomplished that. Current also needs to pass through the indicator's signal reading circuitry. We accomplished that as the current passed from the -Out lead through the indicator and back to the load cell through the +Out lead. Because of the high internal impedance (resistance) of the indicator, very little current flows between -Out and +Out.

Since there is a potential difference between the -In and +In leads, there is still current flow from -In through T_2 and C_2 back to +In, and from -In through C_1 and T_1 back to +In. The majority of current flow in the circuit is through these parallel paths. Resistors are added in series with the input lines. These resistors compensate the load cell for temperature, correct zero and linearity. Let's look at a load cell bridge circuit in mathematical terms to help in understanding the bridge circuit in both a balanced and unbalanced condition. Our Wheatstone bridge can either be drawn in a conventional diamond shape or as shown in Figure 6-3. Either way, it is the same circuit.

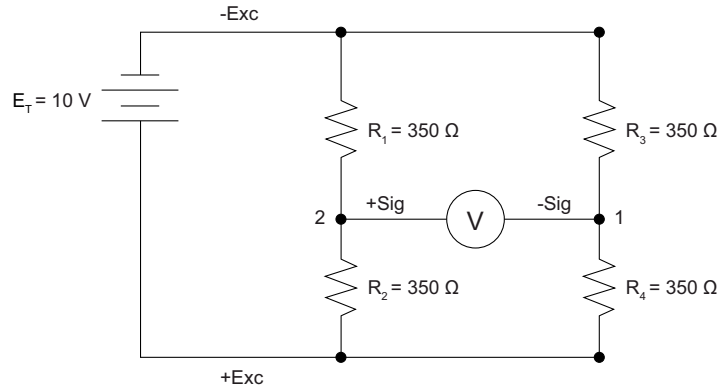

Figure 6-3. Wheatstone Bridge

We have replaced the ammeter with a voltmeter which will represent the display on our weight indicator. Also, the leads connected to our indicator are designated +Sig and -Sig. These represent our positive and negative signal leads. A 10 volt battery represents our indicator's power supply that provides the precise voltage to excite or power the load cell. The resistance values represent our four strain gauges which make up our load cell.

Since there is no load on our cell, all strain gauge resistances are the same. Using Ohm's Law we can figure the voltage drops at points 1 and 2. Each branch contains $350\ \Omega + 350\ \Omega = 700\ \Omega$ of resistance. The current flow in the branch is the branch voltage divided by the branch resistance.

$$\begin{aligned}
 I_{R1 + R2} &= \frac{E_{R1 + R2}}{R1 + R2} & I_{R3 + R4} &= \frac{E_{R3 + R4}}{R3 + R4} \\
 &= \frac{10\text{ V}}{700\ \Omega} & &= \frac{10\text{ V}}{700\ \Omega} \\
 &= 14.3\text{ mA or }0.0143\text{ A} & &= 14.3\text{ mA or }0.0143\text{ A}
 \end{aligned}$$

To figure the voltage at point 1 we can use Ohm's Law.

$$\begin{aligned}
 E_{R3} &= I_{R3}R3 \\
 &= 0.0143\text{ A} \times 350\ \Omega \\
 &= 5\text{ V}
 \end{aligned}$$

Since all resistances are equal, the voltage at point 2 is also 5 V. There is no voltage difference between points 1 and 2, thus a zero reading is displayed on our indicator.

Now let's place a force on our load cell. Our force caused R_1 and R_4 to go into tension, which increased their resistances. R_2 and R_3 went into compression, which decreased their resistances. These changes are depicted in the following figure.

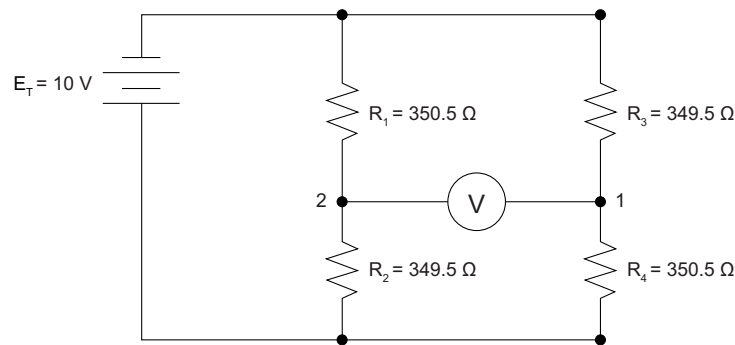

Figure 6-4. Wheatstone Bridge

Notice that the individual branch resistances still total 700Ω , so there is still 0.0143 A of current in each branch of our circuit. However, there is a potential difference between points 1 and 2, thus a reading is displayed on our indicator. Let's calculate the potential difference.

To find the voltage at point 1 we will calculate the voltage drop across R_3 . We know the current through R_3 is 0.0143 A .

$$\begin{aligned} E_{R3} &= I_{R3}R_3 \\ &= 0.0143 \text{ A} \times 349.5 \Omega \\ &= 4.9979 \text{ V} \end{aligned}$$

To find the voltage at point 2 we will calculate the voltage drop across R_1 . Again, we know the current through R_1 is 0.0143 A .

$$\begin{aligned} E_{R1} &= I_{R1}R_1 \\ &= 0.0143 \text{ A} \times 350.5 \Omega \\ &= 5.0122 \text{ V} \end{aligned}$$

To find the potential difference between points 1 and 2, subtract E_{R3} from E_{R1} and find the difference to be 0.0143 V or 14.3 mV .

We see that our bridge has become unbalanced and the potential difference across the bridge is 14.3 mV . The indicator is calibrated so a certain millivolt reading would correspond to a certain weight measurement. As we previously stated the indicator draws current. But its internal resistance is so high that the current it draws is negligible and has no effect on load cell operation.

7.0 Rice Lake Weighing Systems Calibration Certificate

1. Model No.	50210-25
2. Serial No.	37647
3. Capacity	25 lb
4. Output	3.0678 mV/V
5. Excitation	10 Volts
6. Non-Linearity	< 0.010 % Full Scale Output
7. Hysteresis	< 0.010 % Full Scale Output
8. Zero Balance	- 0.0230 mV/V
9. Input Resistance	375 Ohms Nominal
10. Output Resistance	350 Ohms
11. Temperature Effect	
Output	< 0.0005 % / F
Zero	< 0.0010 % / F
Insulation Resistance	5000 Mega Ohms at 50 VDC
Cable Length	20 ft
NTEP Certificate No.	****
Minimum Dead Load	****
Class	****
V min	****
n Maximum	****
Load Cell Usage	****
Safe Load Limit	****

Wiring	
Red	+ Input
Green	+ Output
White	- Output
Black	- Input

Table 7-1. Wiring Color Code

This Page Intentionally Blank.

Weigh Modules

8.0	Weigh Modules: Single-Ended Beam	25
8.1	Introduction	25
8.1.1	General Mounting Principles	25
8.1.2	Single-Ended Beam Orientation	25
8.2	SURVIVOR® RL1700 HE Series Weigh Modules	26
8.3	RL50210TA Weigh Modules	27
8.4	RL1800 / SURVIVOR RL1855 HE-HS Weigh Modules	28
8.5	RL1900 Weigh Modules	29
8.6	Paramounts® HS and Paramounts® EP	30
9.0	Weigh Modules: Double-Ended Beam	32
9.1	Introduction	32
9.1.1	General Mounting Principles	32
9.1.2	Double-Ended Beam Orientation	32
9.2	RL1600 Weigh Modules	33
9.3	SURVIVOR RL2100 HE Weigh Modules	34
9.4	EZ Mount 1 Weigh Modules	35
9.5	Translink™ Truck Scale Weigh Modules	36
9.6	MVS Truck Scale Modules	37
10.0	Weigh Modules: Compression Canisters	38
10.1	Introduction	38
10.1.1	General Mounting Principles	38
10.2	RLC Weigh Modules	39
11.0	Weigh Modules: Tension Mounting (S-Beam)	40
11.1	Introduction	40
11.1.1	General Mounting Principles	40
11.2	ITCM Mounts	41

8.0 Weigh Modules: Single-Ended Beam

Rice Lake Weighing Systems offers a wide variety of weigh module styles, including the industry's only environmentally protective modules. This section includes only some of the weigh modules offered by Rice Lake Weighing Systems, along with information on the design, construction, features and applications of these weigh modules. For a complete list of the weigh modules offered by Rice Lake Weighing Systems and additional specifications, visit our website at www.ricelake.com/lcwm.

Please refer to the Load Cell Guide for the load cell options of all the Rice Lake Weighing Systems' weigh modules.

8.1 Introduction

Single-ended beam load cells offer many advantages when used in well-designed weigh modules. Modules using single-ended beam load cells have a low profile and are generally self-checking. Load cell replacement is possible in most single-ended beam mount systems by raising the vessel only enough to remove pressure from the cell.

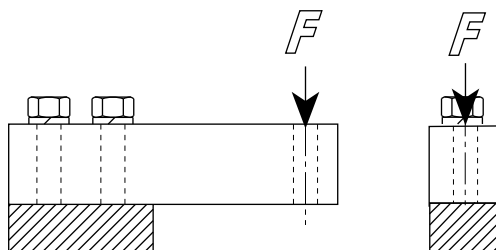

Figure 8-1. Single-Ended Beam

8.1.1 General Mounting Principles

- The mounting surface should be flat and level.
- The mounting bolts should be torqued to specified values.
- The mounting block should be thick enough to provide adequate threads for the mounting screws.
- The corner of the mounting surface (where the cell cantilevers out) must be hardened to prevent peening.
- The mounting bolts should be at least grade five to prevent stretching or the possibility of breaking.
- The load should be applied vertically through the center line of the load hole (the load may be applied from above, as illustrated in Figure 8-1, or may be hung from below).
- The load introduction must provide flexibility to avoid the transmission of extraneous forces and to tolerate the unavoidable deflection of the load cell itself.

8.1.2 Single-Ended Beam Orientation

Figure 8-2 illustrates four different vessels and recommended mounting configurations for single-ended beam weigh modules. The vessels on the left illustrate a vertical cylindrical vessel. Note that the longitudinal axis through each load cell points towards the center of the vessel.

This principle could also be used for the vessels to the right, if it were convenient to mount the cells in each corner with the longitudinal axis pointing toward the center. However, it may be more convenient, and is acceptable, to mount the cells as illustrated. As these cells are relatively immune to extraneous forces applied along the longitudinal axis of the cell, it should point in the direction of any prevalent side force (for example, on a roller conveyor, the load cells should point in the direction of travel).

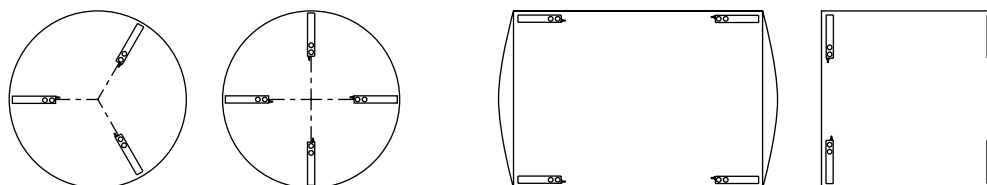

Figure 8-2. Single-Ended Beam Orientation

8.2 SURVIVOR® RL1700 HE Series Weigh Modules

These light- to medium-capacity modules use single-ended beam load cells and offer precision-machined, weld-less construction to maximize washdown cleaning effectiveness. This design, coupled with integral jacking/shipping bolts, eases installation and minimizes maintenance costs. OIML C3-certified load cells in capacities from 5 to 5,000 kg provide accurate, consistent weighments. The unique design of the RL1700 HE weigh module isolates the load cell from side loads and overloads, minimizing load cell mechanical damage and eliminating the need for extraneous hardware. The RL1700 HE weigh module offers an IP66/68 rating to ensure reliable performance in moisture-laden environments.

Allowable Movement

Figure 8-3 illustrates the RL1700 HE module's capability to handle movement. The load may be checked in one of two directions. This allows positioning in one of two orientations for proper checking.

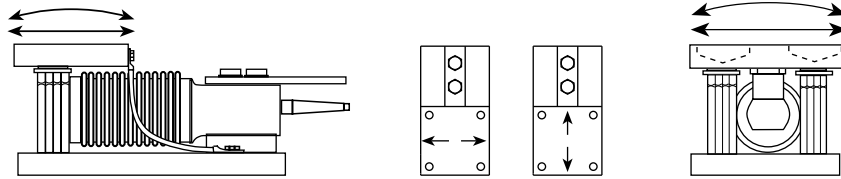

Figure 8-3. SURVIVOR RL1700 HE

Construction and Features

- All stainless steel construction.
- Hermetically sealed, stainless steel load cells, IP66/68.
- OIML certified load cells from 5 to 5,000 kg.
- Bolt-in-place design; module bolts directly to tank leg without requiring additional load buttons or mounting plates.
- Self-checking with lift-off/tip-over protection and jacking/shipping bolts.
- Load cell is isolated from overload in all directions.
- Weldless construction retains less residue and allows fast, thorough cleaning.
- NTEP certified load cells are available upon request. Please visit our website at www.ricelake.com/lcwm for more information.

Typical Applications

A typical application for the SURVIVOR RL1700 HE is multi-ingredient micro-batching as shown in Figure 8-4. Additional applications include meat and poultry processing, chemical batching/blending and dye/ink blending.

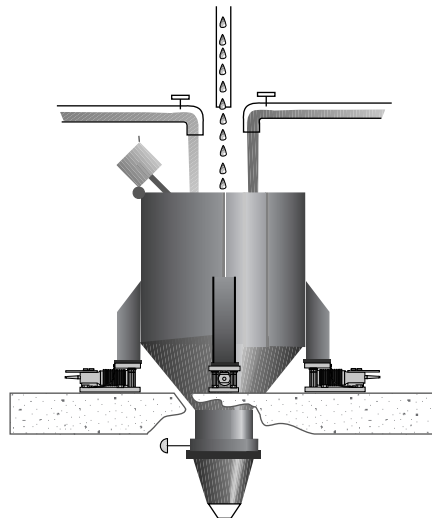

Figure 8-4. SURVIVOR RL1700 HE
in Micro-Ingredient Batching

8.3 RL50210TA Weigh Modules

These low-capacity modules use single-ended beam load cells and provide a cost-effective alternative for low-range weighing needs with capacities from 50 to 2,500 lb. A variety of features makes this module easy to install and an exceptional choice for various indoor weighing applications where checking requirements are low. Environmentally protected load cells, neoprene isolation/compression mounts and other Rice Lake components are the key to this module's outstanding performance. The direct connection of the vessel to the flexible neoprene pad also acts to cushion shock loads.

Allowable Movement

Figure 8-5 illustrates the RL50210TA module's capability to handle movement. The arrows indicate the various means by which the load introduction plate can move relative to the cell to minimize the transfer of extraneous forces.

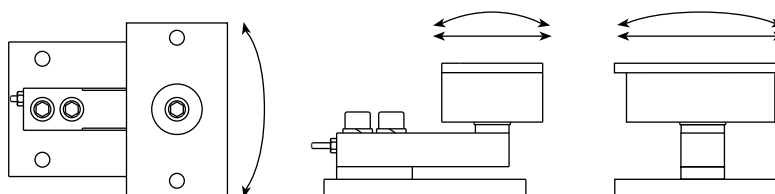

Figure 8-5. RL50210TA

Construction and Features

- Large base plate and spacer washer, the load cell is attached or bolted directly to the base plate.
- Environmentally protected load cells.
- Load introduction through a steel plate bonded to a neoprene pad accommodates vessel movement in all directions.
- Neoprene isolation/compression mounts allow for minor misalignment, thermal expansion and shock absorption.
- Mild steel modules available in capacities from 50 to 2,500 lb. Stainless steel modules available in capacities from 500 to 2,500 lb.
- Capacities from 500 to 2,500 lb incorporate an overload stop under the free end of the cell for durability.
- Some capacities are NTEP certified. Please visit our website at www.ricelake.com/lcwm for more information.

Typical Applications

These modules should be attached so their longitudinal axis aligns with the direction of greatest expected movement of the vessel or conveyor. On a roller conveyor, this would normally be along the line of conveyor travel. See Figure 8-6. Typical applications include conveyor/in-motion weighing, small tanks/hoppers and small platform scales where minor shock loading may be a problem.

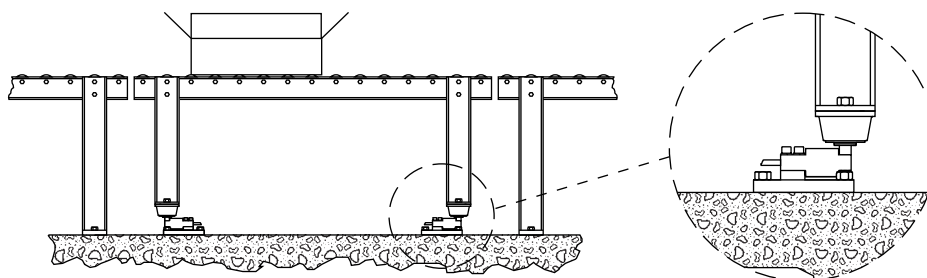

Figure 8-6. RL50210TA on Conveyor

8.4 RL1800 / SURVIVOR RL1855 HE-HS Weigh Modules

These weigh modules use single-ended beam load cells in center-pivoted modules with capacities from 250 to 10,000 lb per module. While these are compression-style modules, the cell is actually mounted in tension since the load is introduced through a center loading bolt in a hanging trunnion suspended beneath the load cell. The trunnion can pivot in all directions on a set of spherical washers, allowing the top plate (attached to the vessel) to rock without twisting the load cell. This arrangement makes the modules self-centering, and able to accommodate movement in all directions. This module is self-checking and provides lift-off protection.

RL1800 and RL1855 HE-HS modules allow the installer to adjust overall height easily with a center loading bolt that is attached to the hanging trunnion. This adjustment feature speeds the process of equalizing the load between all modules. These modules allow load cell removal and replacement without raising the tank—an important consideration in some installations.

Allowable Movement

Figure 8-7 illustrates the RL1800 and RL1855 HE-HS modules with arrows indication allowable movement.

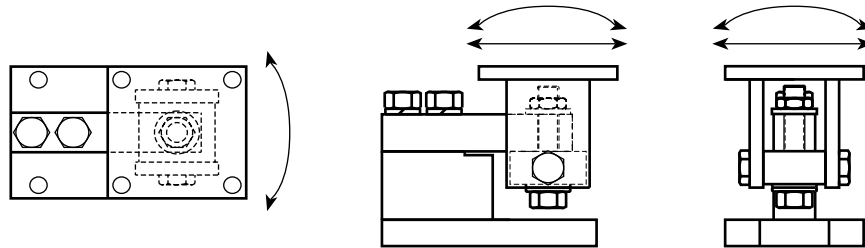

Figure 8-7. RL1800 and RL1855 HE Modules on Horizontal Cylindrical Tank

Construction and Features

- A base plate and spacer support the load cell.
- A trunnion block is suspended below the free end of the cell and is attached to the cell using a bolt in tension which is screwed into a threaded load hole. A spherical washer set is placed between the bolt head and block.
- A chair arrangement is attached to the trunnion block through pivot screws, and the load is applied to the top plate of this chair. This arrangement allows the chair to move in the directions indicated in Figure 8-7.
- Self-checking design with lift-off/tip-over protection and lateral restraint.
- The module provides height adjustment.
- Accommodates a broad range of alloy steel, stainless steel and hermetically sealed stainless steel load cells, including painted alloy and stainless steel load cells.
- RL1800 module is available in capacities from 500 to 10,000 lb in both mild steel and stainless steel, while the RL1855 HE-HS module is available in capacities from 1,000 to 10,000 lb in stainless steel.
- RL1855 HE-HS module has a PTFE-jacketed cable and integral conduit adapter to heighten chemical and moisture resistance.
- Some capacities are NTEP certified. Please visit our website at www.ricelake.com/lcwm for more information.

Typical Applications

Typical applications for the RL1800 are conveyors and medium-capacity tanks and hoppers. Applications for the RL1855 HE include chemical batching/blending, fertilizer blending and medium-capacity tanks and hoppers as well.

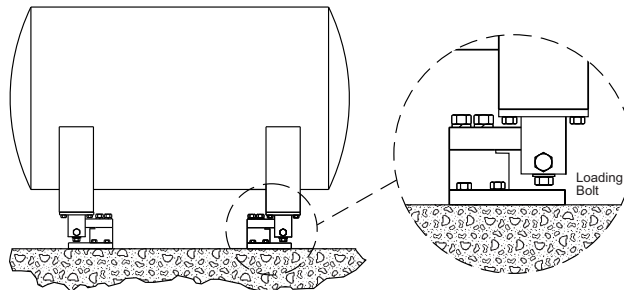

Figure 8-8. RL1800 and RL1855 HE Modules on a Horizontal Cylindrical Tank

8.5 RL1900 Weigh Modules

The RL1900 weigh module is similar in design to the RL1800, but accommodates slightly more lateral movement than the RL1800. This weigh module is suited for tank, hopper and bin weighing operations with medium-range capacities. Each module combines multi-directional movement and self-checking capabilities.

Allowable Movement

Figure 8-9 illustrates the RL1900 modules with arrows indication allowable movement.

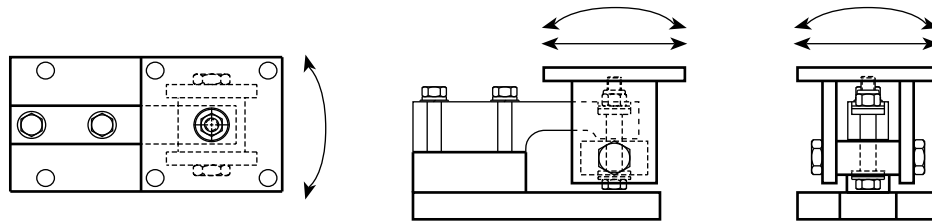

Figure 8-9. RL1900 Modules

Construction and Features

- A base plate and spacer support the load cell.
- A trunnion block is suspended below the free end of the load cell. It is attached to the load cell using a bolt which passes through the clearance load hole and is retained by a nut at the top of the cell. Two spherical washer sets are used; one sits between the bolt head and trunnion block, the other sits between the nut and the top of the load cell (which is counterbored to accept the washer set).
- A chair arrangement is attached to the trunnion block through pivot screws; the load is applied to the top plate of this chair. This arrangement allows the chair to move in the directions indicated in Figure 8-9.
- This module allows slightly greater lateral movement than the RL1800 by virtue of the fact that the suspension bolt passes through a clearance load hole in the cell and has spherical washer sets at the top and bottom.
- Self-checking design with lift-off/tip-over protection and lateral restraint.
- The module provides height adjustment.
- Available in capacities from 1,000 to 10,000 lb in stainless steel.

Typical Applications

Typical applications for the RL1900 are medium-capacity tanks, bins and hoppers, as well as washdown or corrosive applications.

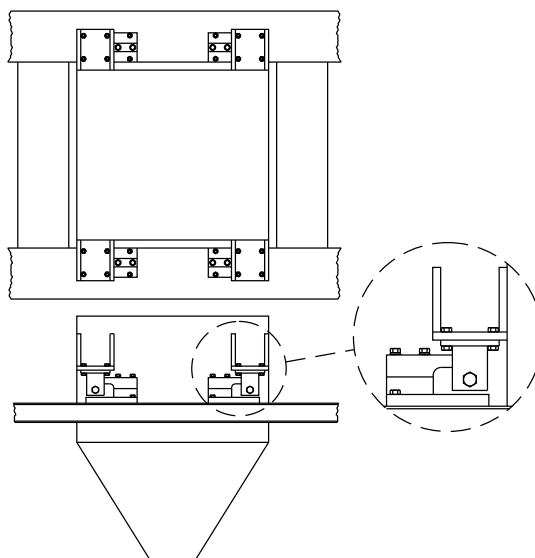

Figure 8-10. RL1900 Modules on Hopper Scale

8.6 Paramounts® HS and Paramounts® EP

The versatile Paramounts vessel weighing system consists of three different weigh modules, which together make a complete system of fixed and sliding modules with single-ended load cells. This unique system allows a vessel to expand freely on sliding modules, yet the system is self-checking. All models are available in capacities up to 2.3 to 100 kN (500 to 22,500 lb).

Allowable Movement

- Fixed-Pin Module** – With the fixed-pin module, the load is transferred from the top plate to the load cell via a load pin which enters a counterbore in the top plate and load cell. The pin acts as a pivot point and only allows the top plate to rotate while fixing the corner of the vessel.
- Free-Sliding Module** – With the free-sliding module, the load pin has a flat top surface on which the top plate is free to slide in all directions. To minimize friction, the top surface of the pin is PTFE-coated and slides on a smooth stainless steel slider plate. The cleanliness of these two surfaces is assured by a neoprene suction seal.
- Side-Stop Module** – The side-stop module uses the same PTFE-coated pin and stainless steel slider plate, but in addition it has side bumpers. These bumpers check the top plate movement laterally. The top plate is checked to move only in the direction of the longitudinal axis of the load cell.

A three-cell system uses one of each style of module; all additional modules are free-sliding.

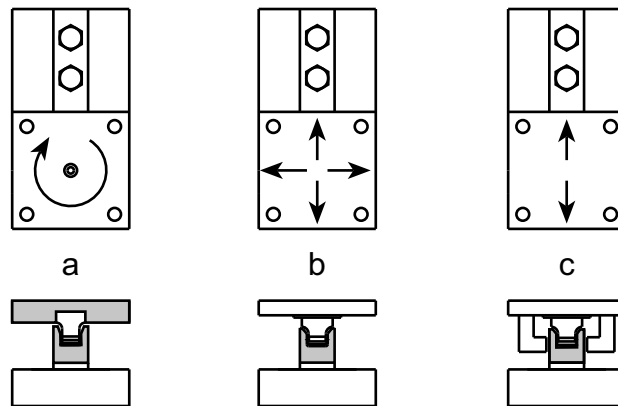

Figure 8-11. The Three Module Designs of the Paramounts System Include the (a) Fixed-Pin Module, (b) Free-Sliding Module and (c) Side-Stop Module

Construction and Features

- **No Torsional Effects:** All SB4, SB10 and SB5 load cells incorporate a blind hole for load introduction. The load is introduced via a convex loading pin. The convex surface allows the module's top plate to rock without twisting the cell. The load pin is centered in the load hole by a pliable polymer "O" ring. The bottom of the blind hole is located on the neutral axis of the Flintec sensing section. Therefore, torsional effects are virtually eliminated.
- **Jacking Screw and Lift-Off Protection:** Each module consists of a base plate to which the load cell is attached and a top plate through which the load is introduced. A safety check screw is rigidly fixed to the top plate and passes through a large clearance hole in the washer plate attached to the base plate. This screw prevents lift-off and also may be used to jack up the empty vessel for load cell replacement.
- **Allows Movement:** There are three different styles of modules resulting from differences in the top plate and loading pin design. Each serves as part of a complete system that allows free movement of the attached vessel.
- **Matched Outputs:** All Paramounts load cell kits use SB4 and SB5 stainless steel load cells with outputs matched to $\pm 0.07\%$. This eliminates corner trimming at initial installation or recalibration when a load cell is replaced.
- **Paramounts HS** mounts are constructed of mild steel and the **Paramount HE** are constructed in stainless steel. Both come with stainless steel, hermetically sealed load cells. **Paramounts EP** models come standard with mild steel mounts and stainless steel, environmentally protected load cells.
- Available in capacities from 2.3 to 100 kN (500 to 22,500 lb) in either mild steel or stainless steel.
- Some capacities are NTEP certified. Please visit our website at www.ricelake.com/lcwm for more information.

Typical Applications

A three-module system would use one of each module. Scales requiring more than three modules use additional free-sliding modules. Figure 8-12 is a typical example of a six-module system. The fixed pin module fixes the vessel in the corner, allowing it to rotate about the loading pin only. The vessel will expand outward from this corner. The side-stop module placed at the opposite end keeps the vessel in check but does not restrict the expansion. The use of four free-sliding modules ensures that the vessel's expansion/contraction is unrestricted in either direction.

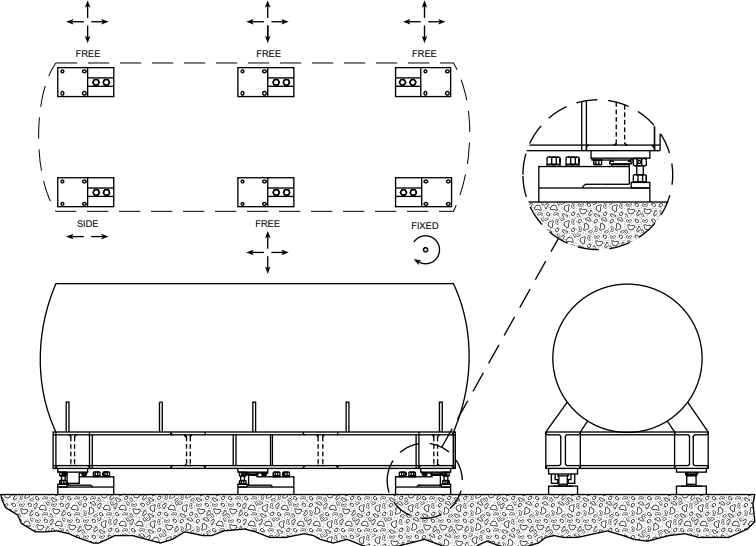

Figure 8-12. Paramounts Mounting System on Cylindrical Tank

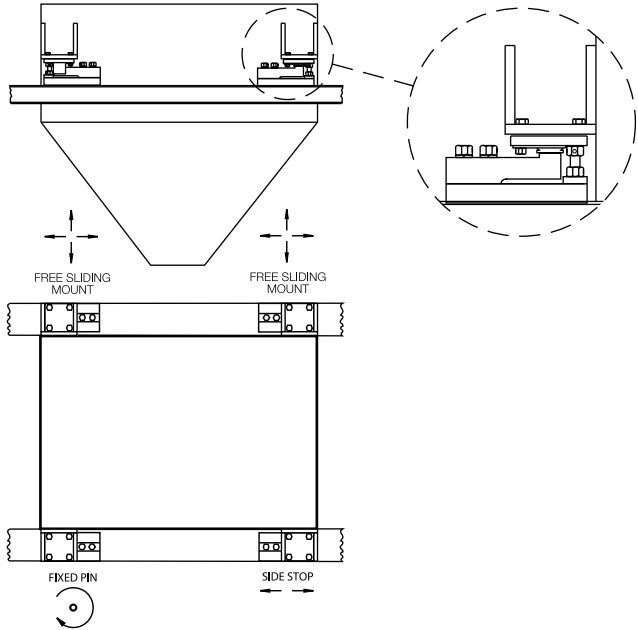

Figure 8-13. Paramounts on Suspended Hopper

9.0 Weigh Modules: Double-Ended Beam

9.1 Introduction

Double-ended shear beams are medium- and high-capacity workhorses that are rugged, stable, and able to handle side loads well. The modules come in two varieties, an end-supported cell loaded in the center and a center-supported cell loaded at the ends. The end-loaded cell is used in the Translink hanging-link truck scale module described later in this section. The more common center-loaded version described below is used in the RL1600, RL2100 HE, EZ Mount 1 and MVS mounting systems.

Figure 9-1 shows some important guidelines for applying load to a center-loaded, double-ended shear beam and for orienting a module using this type of load cell.

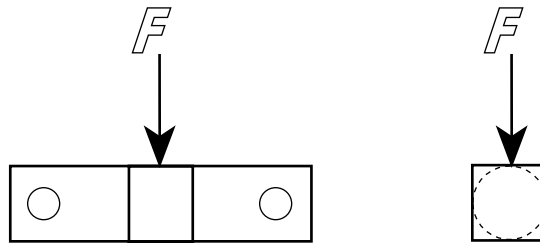

Figure 9-1. Double-Ended Beam

9.1.1 General Mounting Principles

- The load cell should be horizontal in both directions.
- The load should be applied vertically through the cell's center.
- The load should be introduced without producing a twisting effect around the center.
- The load must not move along the cell.

9.1.2 Double-Ended Beam Orientation

In Figure 9-2, we illustrate the best mounting position of double-ended beams for several vessel shapes, where a line from the center of the vessel is at a right angle to the longitudinal axis through the load cell. The mounts for these cells allow the least restricted vessel movement. This is particularly important when significant thermal expansion/contraction is expected.

Some double-ended beam modules should be oriented with the load cell's longitudinal axis in line with the expected movement. On a truck scale, that will normally be in the direction of truck travel.

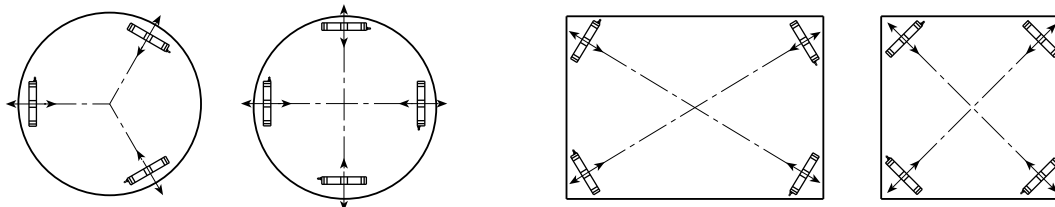

Figure 9-2. Double-Ended Beam Orientation

9.2 RL1600 Weigh Modules

These assemblies are suitable for medium- to heavy-capacity applications because of the inherent strength and stability of the double-ended center-loaded cell which is supported at both ends on pins. The modules are self-checking in all directions while allowing some freedom for the vessel to expand/contract in a single direction by sliding on the mounting pins. The modules also offer lift-off protection to prevent the tank from accidental tipping.

The RL1600 module is a rugged and economical module for use where minimal expansion/contraction movement is expected. Precise alignment is critical with these modules, as there is little room for misalignment with the clamping yoke that holds the load plate to the load cell. Load cell replacement requires raising the vessel only an inch to remove the cell.

The RL1600 series modules are available in either fabricated mild steel or cast iron, and in fabricated stainless steel where extra corrosion protection is required.

Allowable Movement

This module allows limited movement in a direction perpendicular to the longitudinal axis of the load cell.

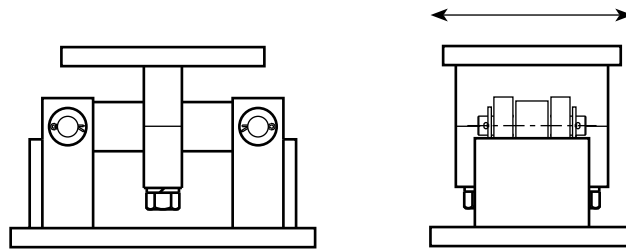

Figure 9-3. RL1600 Weigh Module

Construction and Features

- A rigid base plate with four cross-drilled uprights to support the pins holding the load cell.
- A chair clamps around the load cell's center. This arrangement allows the cell freedom to slide laterally a short distance on the pins.
- The module is self-checking in all directions.
- Available in mild steel and stainless steel construction in capacities from 1,000 to 75,000 lb, and in cast iron from 1,000 to 25,000 lb.
- Load cells used are not NTEP approved.

Typical Applications

Typical applications for the RL1600 are medium- to heavy-capacity tanks, bins and hoppers, as well as bulk material management.

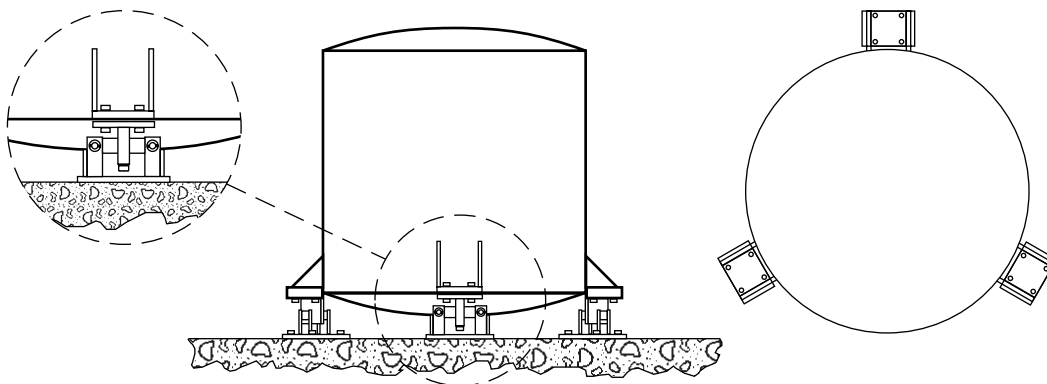

Figure 9-4. RL1600 Weigh Modules on Low-Profile Tank

9.3 SURVIVOR RL2100 HE Weigh Modules

These medium- to heavy-capacity modules are available in two sizes with capacities ranging from 25,000 to 100,000 lb. The SURVIVOR RL2100 HE uses a double-ended shear beam load cell and is ideally suited for tanks, hoppers and reactors that are subject to harsh, hostile environments. This module provides superior corrosion, moisture ingress and mechanical protection. In the majority of applications, the assemblies are self-checking and held captive with no need for check or stay rods.

The load cells available for the RL2100 HE weigh modules are NTEP approved and available with features to best fit application requirements, such as construction, environmental and ingress protection. Available load cells include RL75060S, RL75058S-LP, RL75058-LP, RL75058I, 65058A and 65058S.

Allowable Movement

Figure 9-5 illustrates the RL2100 HE module's capability to handle movement.

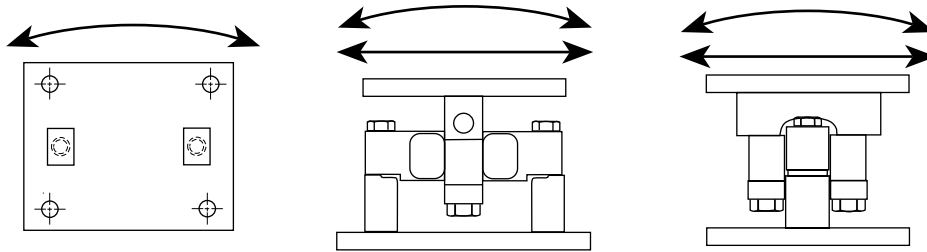

Figure 9-5. SURVIVOR RL2100 HE

Construction and Features

- Bolts directly to tank leg with bolt-in-place module design without requiring additional load buttons or mounting plates.
- Tolerates eccentric loads and side loads of up to 100% of capacity.
- PTFE jacketed cable is available for maximum chemical resistance.
- All stainless steel construction.
- Self-checking design with lift-off/tip-over protection.
- Load cells used are NTEP approved.

Typical Applications

Typical applications for the SURVIVOR RL2100 HE include heavy-capacity tanks, blenders, reactors and bulk inventory management, as well as petroleum refining process control and chemical blending/batching.

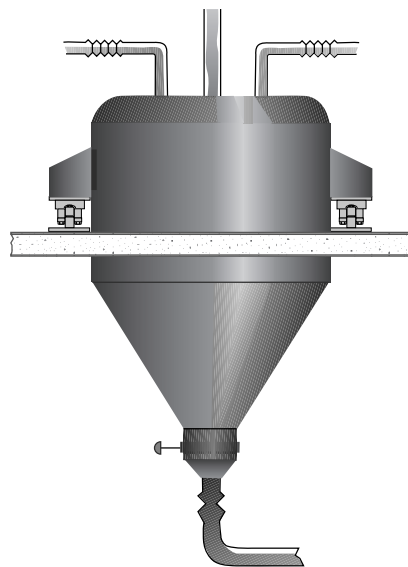

Figure 9-6. SURVIVOR RL2100 HE in Heavy-Capacity Application

9.4 EZ Mount 1 Weigh Modules

In applications where substantial thermal expansion/contraction is expected or room is not available to raise a vessel significantly for load cell replacement, the EZ Mount 1, also using a double-end center-loaded weigh module, is an excellent choice to handle vessel movement and limited space requirements.

The EZ Mount 1 uses a round load cell that allows the top loading plate to pivot and correct minor alignment problems. The module can also accommodate substantial movement in the direction perpendicular to the longitudinal axis of the load cell.

The load cell in the EZ Mount 1 is supported on hardened circular spacers. Screws secure it to the base plate. The top chair is held captive by removable pins on top and bottom of the load cell. This allows the load cell replacement without raising the vessel, but merely by taking the load off the module.

EZ Mount 1 weigh modules are available in alloy steel or stainless steel in capacities from 5,000 to 250,000 lb.

Allowable Movement

Figure 9-7 illustrates the EZ Mount 1 weigh module with arrows indicating allowable movement.

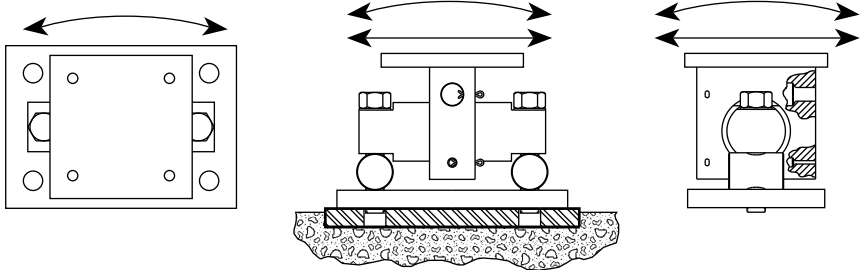

Figure 9-7. EZ Mount 1 Weigh Module

Construction and Features

- Simplified design allows bolting directly to tank and floor.
- Unique sliding pin design compensates for thermal expansion/contraction.
- This arrangement allows the chair to move in practically all directions, as illustrated in Figure 9-7, while providing checking in all directions.
- The load cell can be removed easily by raising the vessel only enough to relieve the load from the cell.
- Low-profile design.
- Available in capacities from 5,000 to 250,000 lb in mild steel and in capacities from 5,000 to 250,000 lb in stainless steel.
- Most capacities are NTEP certified. Please visit our website at www.ricelake.com/lcwm for more information.

Typical Applications

Typical applications for the EZ Mount 1 include medium- to heavy-capacity tank and hopper weighing applications.

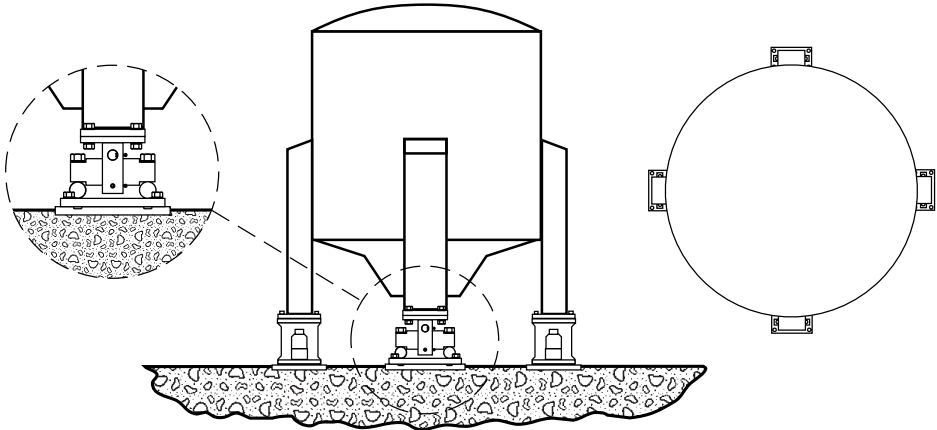

Figure 9-8. EZ Mount 1 Weigh Module Arrangement

9.5 Translink™ Truck Scale Weigh Modules

Self-centering mounting assemblies, such as the Translink, are classified as compression-type mounts that apply load to their cells in a tension manner through a hanging pendulum mechanism below the load cell. The pendulum action gives them their unique self-centering ability.

The modules are commonly used to support a free-floating platform like a truck scale. The platform's horizontal float is limited by bumper pads on all sides. The deck will always return to a central position after lateral movement and not remain in contact with the bumper pads.

Unlike the other double-ended beams described so far, the Translink mounting assembly uses an end-loaded shear beam that is supported by a concave or convex insert in the center that allows the cell to pivot.

Allowable Movement

Figure 9-9 illustrates the Translink weigh module with arrows indicating allowable movement.

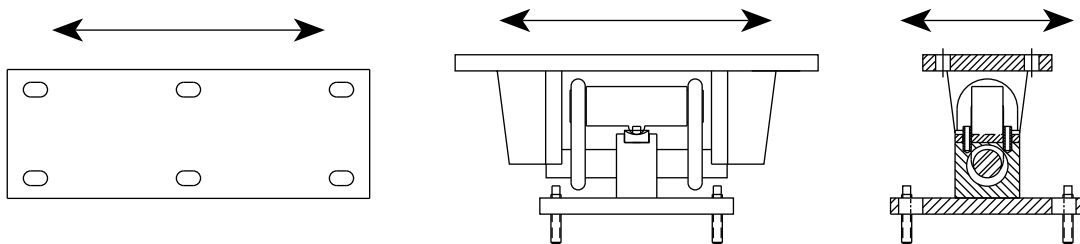

Figure 9-9. Translink Weigh Module

Construction and Features

- A stanchion is welded to a base plate. The stanchion accommodates a hardened convex or concave insert on which the load cell sits. Two roll pins prevent the cell from sliding sideways.
- A forged link hangs from each end of the load cell, supporting a heat-treated load bar which passes through the stanchion. The load bar has circular grooves (corresponding to the loading grooves in the load cell) in which the links sit, and the top chair sits on each end of the load bar.
- Free movement in all directions in the horizontal plane with virtually no friction.
- Completely self-centering, this module has a pendulous action which returns the deck to its original position after it has been disturbed longitudinally or laterally.
- This module is ideally suited for vehicle scales or high-capacity vessel scales.
- This module requires the scale to be checked in the horizontal plane. Stay rods may be used or, because of the self-centering action, bumper bolts are also sufficient. The mount does not provide lift-off protection which must be provided externally if required on a vessel scale.
- The Translink module is available in mild steel in capacities from 25,000 to 100,000 lb.

Typical Applications

Typical applications for the Translink weigh module include truck scale mounts and heavy-capacity horizontal tanks.

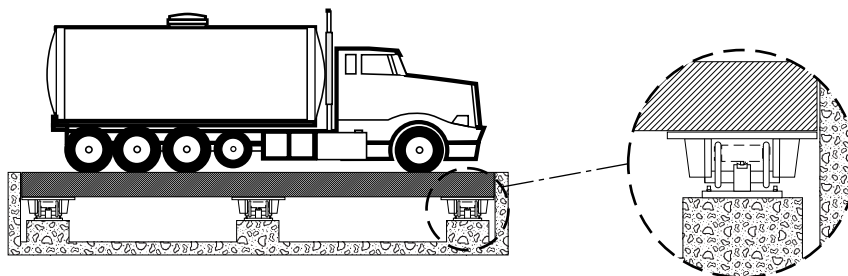

Figure 9-10. Translink Truck Scale Arrangement

9.6 MVS Truck Scale Modules

The MVS load cell module is used primarily for truck scales and in certain vessel-weighing applications. The modules are constructed of cast iron and are available in load cell capacities from 10,000 to 125,000 lb. The center-link design provides freedom of movement in the longitudinal direction while also self-centering, making this module ideal for vehicle scales.

Unlike the double-ended beams used for the RL 1600 or EZ Mount 1, the MVS module should be mounted with the greatest expected movement aligned with the longitudinal axis of the load cell. In a truck scale, this is normally in the direction of truck travel.

Allowable Movement

Figure 9-11 illustrates the MVS weigh module with arrows indicating allowable movement.

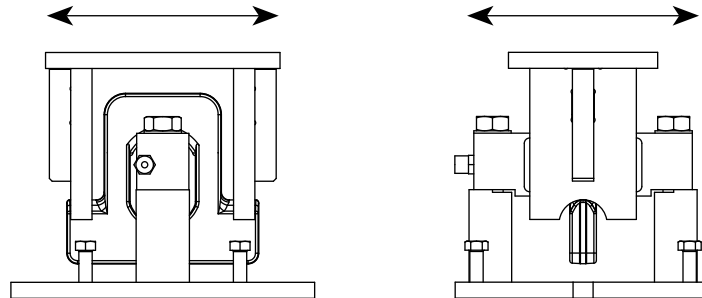

Figure 9-11. MVS Weigh Module

Construction and Features

- The load cell ends are screwed to a rigid U-shaped base plate.
- A link sits over the center of the cell which has a radiused groove. The bottom of this link has two saddle blocks which project outwards. The top girder chair assembly sits on these ears.
- The module is free to move.
- Because the load is suspended by a link, the scale is free to rock back and forth along the longitudinal axis of the load cell. Because of the pendulous action of the link, the scale will return to its original position after being displaced along the longitudinal axis of the cell.
- When a number of modules are fastened to a deck, the modules are restrained from rocking laterally.
- A scale using this module must be checked along the longitudinal axis of the load cell to prevent over-travel. Stay rods or bumper bolts may be used.
- The module does not provide lift-off protection which, if required in a vessel weighing application, must be provided externally.

Typical Applications

Typical applications for the MVS weigh module include truck/track scale conversion and heavy-capacity horizontal tanks.

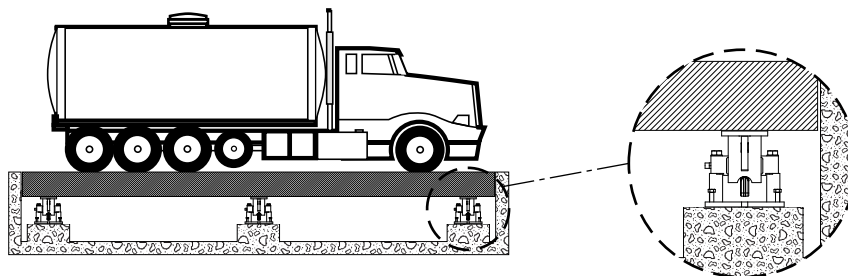

Figure 9-12. MVS Truck Scale Arrangement

10.0 Weigh Modules: Compression Canisters

10.1 Introduction

When mounts are needed in capacities over 100,000 lb, canister load cell mounts are one of the choices available. These cells are good in severe conditions and have proven performance for decades in truck, railroad and heavy-capacity tank applications. Available in capacities to 500,000 lb per mount assembly, most canister mounting assemblies require more components than mounts using beam load cells, especially if the mounts are designed to accommodate expansion.

The load is transferred to the cell through a hardened, convex load button which mates with a hardened flat loading plate. The rounded load button and flat plate tend to promote point loading, minimizing extraneous forces.

10.1.1 General Mounting Principles

- A compression canister should be mounted on a flat plate of sufficient thickness to prevent deflection. The foundation must be rigid.
- The load should be introduced through a spherically radiused load button which is hardened.
- The load must be introduced vertically along the center line of the cell.
- The top plate which contacts the load button must be hardened to prevent peening of the contact point.
- Some external method of both horizontal and vertical checking may be required.

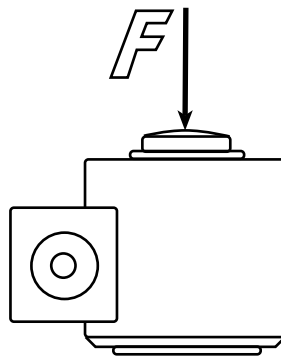

Figure 10-1. Compression Canister Weigh Module

10.2 RLC Weigh Modules

The RLC self-aligning silo mount, together with the RLC load cell family, is an ideal solution for medium capacity process control, batch weighing, silo/hopper and belt scale applications.

The RLC mount incorporates a removable rocker pin design that uses hardened stainless steel components on all load bearing surfaces. The full stainless steel construction guarantees long term reliability, even in the harshest environments.

Allowable Movement

The RLC mount shown in [Figure 10-2](#) tolerates controlled movement in all directions. The silo or hopper is held captive, eliminating the need for additional check rods, unless major load movement is anticipated. The unique design allows the load cell to be easily removed for replacement.

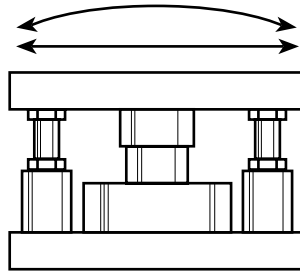

Figure 10-2. RLC Weigh Module

Construction and Features

1. The RLC load cell consists of three concentric rings machined from a single piece of stainless steel. The outer ring rests on the base plate. The middle ring contains four circular strain gauges. The inner ring accepts the load and deflects vertically, activating the strain gauges in the middle ring.
2. A separate loading pin fits into the load cell's inner ring and into a hardened bearing cup on the top plate of the mount. The inner ring's vertical travel is limited by the base plate, providing positive overload protection at 150% of capacity.
3. The RLC load cell is held captive in the mount by three pins at the cell's outer circumference. To install or replace the load cell, the mount's top plate need only be raised with the integral jacking screws a fraction beyond the height of the pins.
4. The jacking screws provide lift-off protection as well as lateral self-checking capabilities to eliminate the need for check rods.

Typical Applications

Typical applications for the RLC weigh module include medium-capacity tanks, bins and hoppers, as well as washdown or corrosive applications. It can also be used in process control and batch weighing.

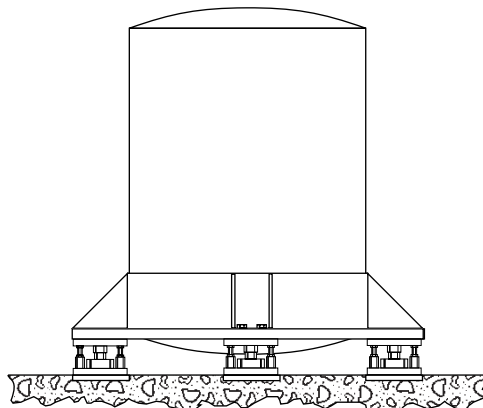

Figure 10-3. RLC Weigh Module Arrangement

11.0 Weigh Modules: Tension Mounting (S-Beam)

11.1 Introduction

Suspension mounting with S-beam load cells is often used for light to medium vessels where an existing overhead structure may be used to suspend the vessel.

11.1.1 General Mounting Principles

Figure 11-1 illustrates the correct way to apply load to an S-beam load cell.

- The surface from which the cell is suspended should be rigid and provide minimal deflection under loads.
- The entire suspension should be as long as possible with the load cell placed approximately at the center.
- The center line of the top and bottom rods should pass through the load cell's load holes. The center line through the assembly should be vertical.
- The load cell cable should emerge from the fixed end of the cell so that it does not affect accuracy. Position the load cell in an "S" formation with the cable exiting on the left side.
- The ends of the suspension should be attached to the structure and vessel in such a manner that they are free to move. At a minimum, use a spherical washer set as illustrated in Figure 11-1.
- Use a suitable hardware assembly such as eye bolts or the ITCM system at the load cell to minimize the transmission of extraneous forces.
- Rice Lake recommends that all hardware is of sufficient strength to withstand maximum eccentric axial loading conditions with a minimum of a 5:1 safety factor.

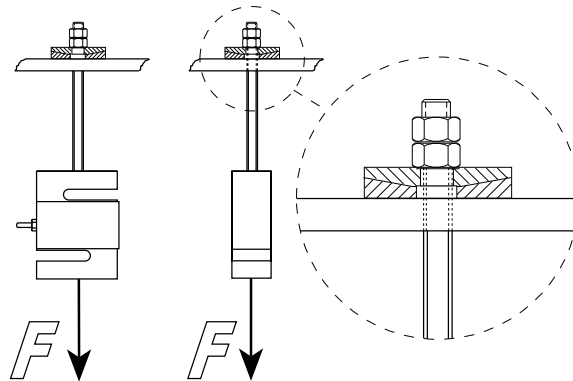

Figure 11-1. S-Beam Weigh Module

11.2 ITCM Mounts

The ITCM assembly is a particularly convenient method of suspending a weigh vessel. The combination of clevises and rod end ball joints ensures that forces detrimental to accurate system performance are isolated from the load cell. In addition, the unique electrical isolation provided to the load cell by this assembly helps prevent damage from stray currents.

Allowable Movement

Figure 11-2 illustrates the use of the ITCM weigh module. This mounting arrangement prevents most of the potential problems caused by extraneous forces acting on S-beam load cells.

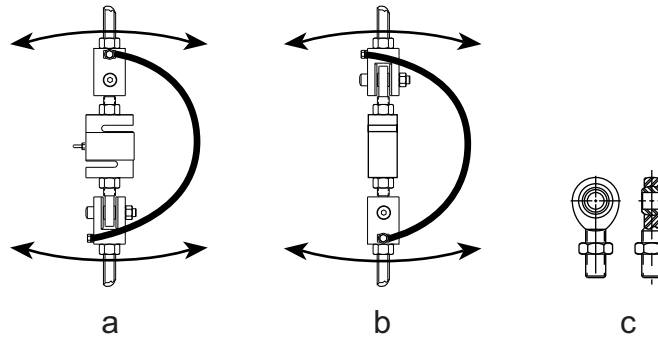

Figure 11-2. ITCM Weigh Module

Construction and Features

- The ITCM consists of a high-precision rod end ball joint which is screwed into each end of the S-beam. The rod end ball joint has a “ball” which is free to rotate in a PTFE bearing; see Figure 11-2(c). A clevis is attached to the rod end ball joint using a shoulder screw. The rod end should be threaded into the load cell ensuring contact with all threads, without touching the main body of the S-beam.
- This arrangement provides excellent alignment between the center lines of the rods and the center line through the cell’s load holes.
- This arrangement allows movement in the directions indicated by the arrows and also allows rotation, thus ensuring that extraneous forces are not transmitted to the load cell.
- The ITCM also incorporates an insulating system which will not allow the flow of stray electrical currents through the load cell. The parallel ground strap provides further protection with an alternate path to ground.
- ITCMs are available in mild steel in capacities from 100 to 20,000 lb using the RL20000I or RL20001 load cell. Stainless steel versions are available in capacities from 100 to 5,000 lb using the RL20000ST, RL20000SS or RL20001HE load cell.
- 20,000 lb ITCM assemblies do not have PTFE lined rod end ball joints.



NOTE: A single ITCM is often used to convert a mechanical truck or hopper scale to electronic. This takes advantage of process control or data collection options available with electronic weighing. The conversion can be accomplished by inserting an ITCM assembly in the steelyard rod without affecting the operation of the mechanical beam or dial which may be retained as a backup.

Typical Applications

Figure 11-3 illustrates what is perhaps the simplest weigh vessel. This works well under the following conditions:

- Weighing self-leveling materials only.
- The vessel is symmetrical about the point of suspension so that the center of gravity rises along the same vertical line each time.

These restrictions ensure that the content's center of gravity is always vertically below the load cell, removing the tendency of the vessel to bind against the bumpers. Bumpers are provided to limit the amount of sway produced if the tank were accidentally hit or subjected to other external forces. Bumpers can only be used with a self-centering vessel mounting arrangement, since the vessel cannot remain in contact with bumpers without causing weight reading errors. The vessel must also be restrained from rotating to prevent suspension hardware from unscrewing.

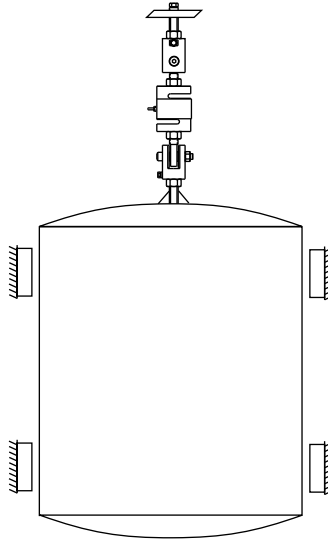

Figure 11-3. ITCM Weigh Module Arrangement

A weigh vessel suspended from a single load cell may be used to weigh solids if horizontal stay rods are used to eliminate the side movement caused by shifts in the content's center of gravity.

The three-load-cell suspension system shown in Figure 11-4 uses three S-beam load cells placed 120° apart on a cylindrical vessel. This avoids the problem of having to adjust the weight carried by each cell, as the inherent stability of a 3-point hanging system will ensure equal loading at each point. To ensure stability, suspension rods should be attached to the vessel at or above the center of gravity of the filled vessel. Though this configuration is inherently stable, special attention is required when significant vibrations, agitation, wind or seismic activities are possible. In this case, bumpers or horizontal check rods should also be employed.

Each support point should be equally rigid and deflect by the same amount when loaded. If not, the load may be transferred unequally, which may overload one or more of the cells.

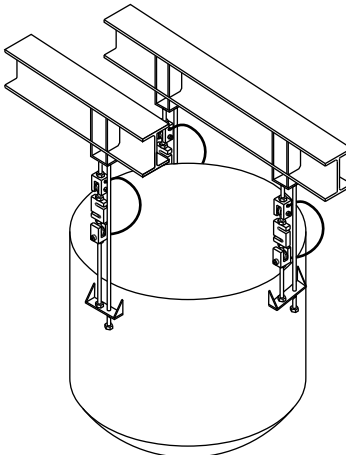

Figure 11-4. Three-Load-Cell Suspension System

The four-load-cell suspension system shown in [Figure 11-5](#) is most common for rectangular hoppers. As mentioned previously, adjustment will be necessary to equalize the load carried by each load cell to within 10% of each other.

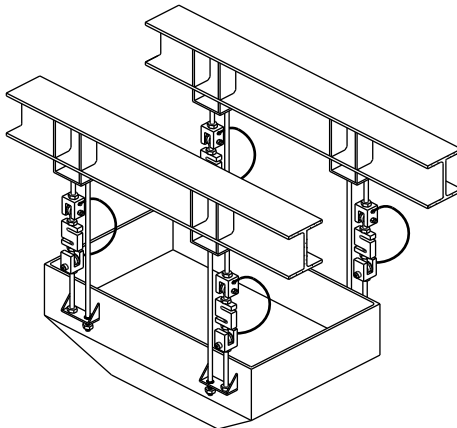

Figure 11-5. Four-Load-Cell Suspension System



NOTE: Each rod passes through a large clearance hole at the lower end and the nuts are loose so there is no interference with the weighing accuracy. All suspended vessel weighing systems must be protected by safety check rods or chains to prevent damage or injury in the event of a failure.

This Page Intentionally Blank.

Vessel Weighing System Design

12.0	Bulk Material Weighing Systems	46
12.1	Custody Transfer	46
12.2	Material Proportioning	46
12.3	Loss in Weight	47
12.4	Common Hopper Scale Arrangements	47
13.0	Maximizing System Accuracy	52
13.1	Environment	52
13.2	Load Cell and Mount	52
13.3	Mechanical/Structural Considerations	53
13.4	Calibration	53
13.5	Operational Considerations	53
14.0	Selecting the Number of Supports and Load Cell Capacity	54
14.1	Number of Supports	54
14.1.1	Suspended Vessels	54
14.1.2	Upright Cylindrical Vessels in Compression	54
14.1.3	Square, Rectangular or Horizontal Cylindrical Vessels Mounted in Compression	54
14.2	Load Cell Capacity	54
15.0	Calculating Thermal Expansion of Vessels and Stay Rods	55
15.1	Stay Rod Expansion/Contraction	55
15.2	Vessel Expansion/Contraction	56
16.0	Calculating Tank Volumes	57
16.1	Formulas for Tank Shapes and Sections	57
16.1.1	Cylinder	57
16.1.2	Portion of Cylinder	57
16.1.3	Horizontal Cylinder (Partially Filled)	57
16.1.4	Frustum of Cone	58
16.1.5	Hemispherical End	58
16.1.6	Spherical Segment	58
16.1.7	Hemispherical End (Partially Filled)	58
16.1.8	Square Prism (Rectangular Cross Section)	59
16.1.9	Square Prism (Square Cross Section)	59
16.1.10	Wedge I	59
16.1.11	Wedge II	60
16.1.12	Frustum of Pyramid	60
16.2	Angle of Repose	60
16.3	Calculation Examples	61
17.0	Wind and Seismic Effects on Vessel Stability	65
17.1	Overview	65
17.2	Wind and Seismic Weigh Module Policy	67
17.3	Wind Forces	67
17.4	Seismic Forces	69

12.0 Bulk Material Weighing Systems

Bulk materials are weighed for various reasons. Although this discussion focuses on the weighing of bulk solids, many of the principles are equally applicable to the weighing of bulk liquids. For the sake of convenience, we have classified bulk material weighing into three general types: custody transfer, material proportioning and loss in weight.

12.1 Custody Transfer

Weighing bulk material on a truck scale is a typical example of custody transfer weighing where material is being traded for dollars. The filled truck is weighed and the known tare weight of the truck is subtracted to determine the net weight of product. This may be done for invoicing or inventory-control purposes. Typically, achieving a predetermined weight is not important in this situation. What is important is knowing how much material entered or left the facility.

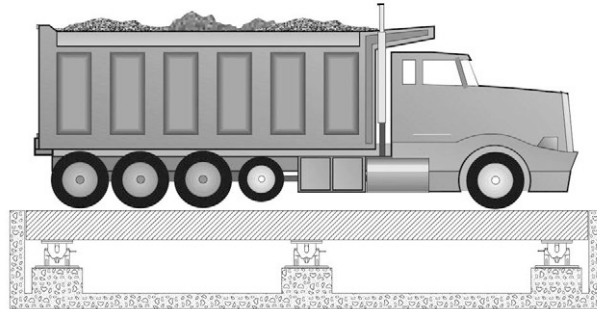

Figure 12-1. Truck Scale Application

12.2 Material Proportioning

Figure 12-2 shows ingredients being weighed on separate scales, then mixed. Each scale must be accurate, or there could be a detrimental effect on the proportions of each ingredient in the finished product.

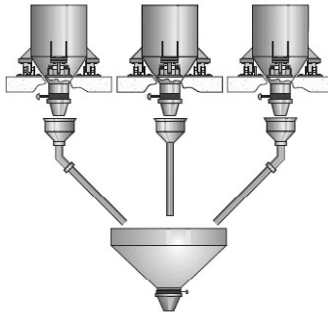

Figure 12-2. Separate Weigh Hoppers

Figure 12-3 shows several materials being mixed to a given recipe and batched one at a time into a single weigh hopper. As all ingredients are weighed in the same weigh hopper, the weighing system must be linear to achieve correct proportioning. It does not need to be calibrated accurately if the final net weight of product is not critical.

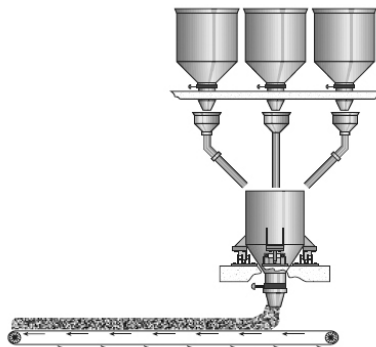

Figure 12-3. Single Weigh Hopper

12.3 Loss in Weight

Figure 12-4 shows an example where the weigh hopper is filled and when the filling process stops, the material is fed out at a controlled rate. The total amount of material supplied to the process may be important, but the rate at which product is fed into the batching process from the weigh hopper is usually more important.

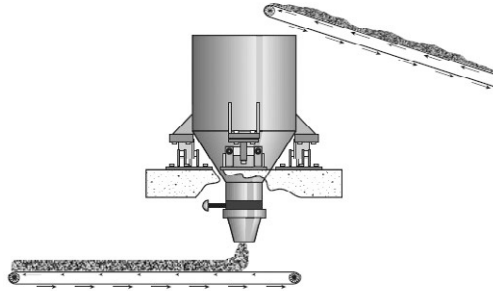

Figure 12-4. Controlled Rate Weigh Hopper

12.4 Common Hopper Scale Arrangements

Arrangement A

One of the simplest hopper weighing systems is illustrated below in Figure 12-5. The weigh hopper may be filled using a feed conveyor, front-end loader, auger, etc., and the material may be removed from the hopper using a discharge conveyor.

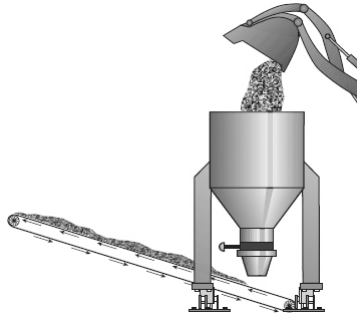

Figure 12-5. Loader Fed Weigh Hopper

Advantages of this system are:

- Low cost compared to other systems.
- Low overall height.

Disadvantages of this system are:

- Slow fill and discharge (low throughput).
- Difficult to achieve an accurate prescribed weight because of inconsistency in input material flow.

Arrangement B

Figure 12-6 below illustrates a weigh hopper positioned directly under the storage silo.

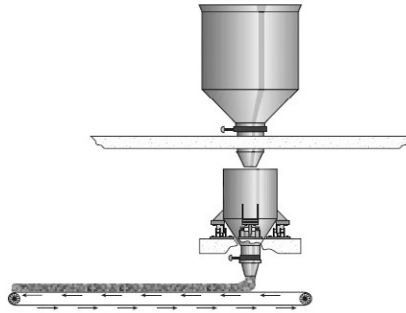

Figure 12-6. Storage Silo Fed Weigh Hopper

Advantages of this system are:

- The weigh hopper is gravity-fed, simplifying the feed process and providing a more uniform flow.
- Faster fill cycle and greater throughput.
- Two-speed fill may be used for greater target accuracy.

Disadvantages of this system are:

- Higher overall height.
- Material must be conveyed higher to storage silo.

Arrangement C

A conveyor-fed system can be improved by adding an upper surge hopper as shown in Figure 12-7. The surge hopper allows the conveyor to be run continuously and isolates the weigh hopper from the sometimes erratic flow of material from the conveyor.

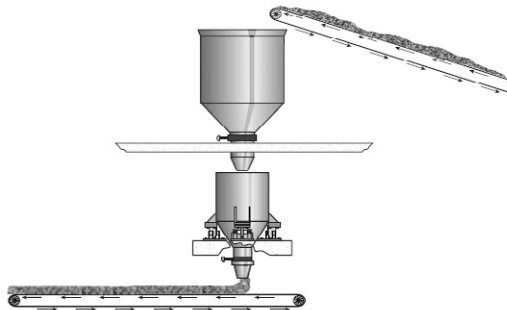

Figure 12-7. Surge Hopper Fed Weigh Hopper

Advantages of this system are:

- Weigh hopper isolated from the feed conveyor.
- The input conveyor can run continuously.
- Surge hopper serves as a buffer to smooth out demand.
- Two-speed fill is possible.
- Faster fill and higher throughput possible.

Disadvantages of this system are:

- Higher overall height.
- Higher cost.
- More complex controls and mechanical arrangement.

Arrangement D

This arrangement is similar to Arrangement C, however, a lower surge hopper has been added to speed up the discharge cycle. This system, shown in [Figure 12-8](#), is typically used in grain loadout systems where multiple drafts are required to fill a rail car or barge. The weight of each draft can be accumulated and the target weight of the final draft adjusted to achieve the desired car net load.

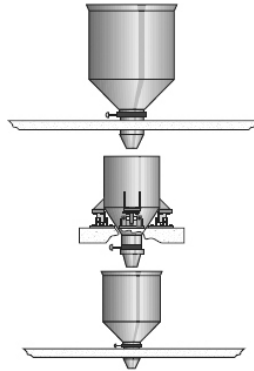

Figure 12-8. Multiple Draft Weigh Hopper System

Advantages of this system are:

- Weigh hopper isolated from the feed conveyor.
- Surge hopper serves as a buffer to smooth out demand.
- Two-speed fill is possible.
- Faster fill, discharge and throughput possible.

Disadvantages of this system are:

- Higher overall height.
- Higher cost.
- More complex controls and mechanical arrangement.

Arrangement E

[Figure 12-9](#) illustrates a single storage silo with two weigh hoppers suspended underneath. This arrangement can be used to provide material continuously to a process. As one hopper is emptying, the other can be filling. If the system is sized correctly, there is no interruption to the material flow on the discharge belt.

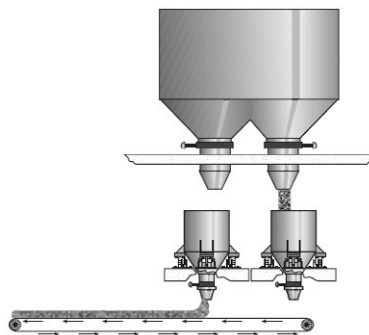

Figure 12-9. Dual Weigh Hopper System

Advantages of this system are:

- Continuous material flow.
- High throughput possible.

Disadvantages of this system are:

- Higher overall height.
- Higher cost than pulse discharge systems.
- More complex controls and mechanical arrangement.

Arrangement F

Figure 12-10 illustrates a loss-in-weight system. This is used where a process needs a batch of material (not more than the capacity of the weigh hopper), but that material needs to be fed to the process at a controlled rate.

The process starts by filling the hopper with at least enough material for the upcoming process. The fill is then stopped and the discharge begins. The rate at which the discharge takes place is controlled by monitoring the “loss in weight” of the hopper and then modulating the discharge rates to maintain the desired flow rate. The discharge may be ended at the completion of the process step, or when a specific amount of material has been discharged.

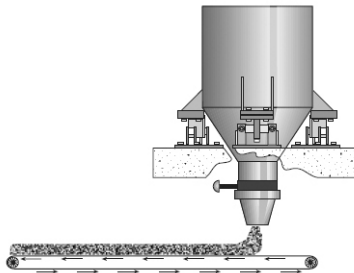

Figure 12-10. Loss-in-Weight System

Advantages of this system are:

- Gives the ability to supply material at a constant rate.

Disadvantages of this system are:

- Complex controls and mechanical arrangement.
- Higher cost than pulse discharge systems.

Arrangement G

Figure 12-11 illustrates a multiple-ingredient batching system where all the ingredients are weighed one at a time in a single weigh hopper.

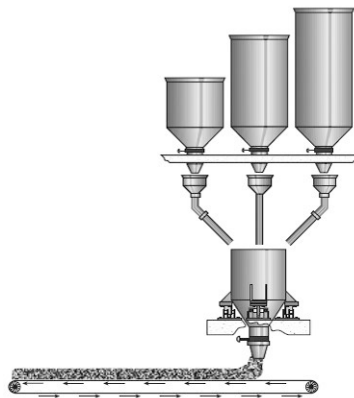

Figure 12-11. Single Weigh Hopper, Multiple-Ingredient Batching System

Advantages of this system are:

- Lower cost than multiple-weigh hoppers.
- Scale calibration may not be critical, as all ingredients are weighed in a single scale, assuring correct proportions.

Disadvantages of this system are:

- The accuracy of minor ingredients may suffer where the scale capacity is large compared to the weight of ingredient.
- System is somewhat slow because each material must be batched one at a time, and the cycle cannot repeat until the weigh hopper has been discharged.



NOTE: Do not attempt to weigh a batch of material which is less than 20 scale divisions since the accuracy will be questionable.

For example, if a hopper scale has a 0.5 lb division size, we recommend not weighing less than a 10 lb batch on that scale. It's better to weigh minor ingredients accurately on a scale suited to the purpose, and then add those ingredients to the batch by hand. For example, if making raisin oatmeal cookies, it may not be too much of a problem to batch-weigh the raisins along with the oatmeal. However, it may be prudent to weigh the salt on a more sensitive bench scale and hand-add it to the hopper at completion of the weigh cycle.

Arrangement H

The system illustrated in [Figure 12-12](#) is a multiple-ingredient batching system which has a separate weigh hopper for each ingredient.

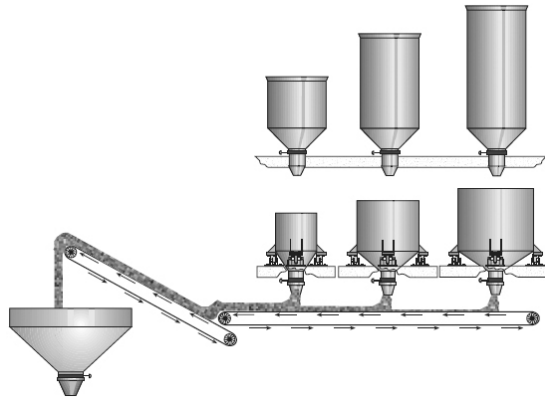

Figure 12-12. Separate Weigh Hoppers, Multiple-Ingredient Batching System

Advantages of this system are:

- Weigh hopper capacity can be sized appropriately for each material so that each weighing is close to the scale capacity, providing greater accuracy.
- Faster throughput, since all materials can be weighed and discharged simultaneously.

Disadvantages of this system are:

- Higher cost.
- Each scale must be accurate to ensure correct proportioning.

13.0 Maximizing System Accuracy

High-accuracy systems are generally considered to have system errors of $\pm 0.25\%$ or less; lower-accuracy systems will have system errors of $\pm 0.50\%$ or greater. Most weight indicators typically have an error of $\pm 0.01\%$, hence, the main source of error will be the load cells and, more importantly, the mechanical arrangement of the scale itself. In vessel weighing, each installation is unique in terms of the mechanical arrangement, site conditions and environmental factors. Therefore, it is impossible to be specific in this publication about the system accuracy that can be achieved. The first requirement is to determine what the customer's accuracy expectations/requirements are, then design the system accordingly. Grouped under subheadings below are recommendations that contribute to high accuracy. It will not be possible to comply with all these recommendations; however, they should be kept in mind when designing a system.

13.1 Environment

- Install the vessel in a controlled environment where seasonal temperature fluctuations are minimized. If this is not feasible, use load cells with temperature compensation specifications that will allow satisfactory performance over the expected temperature range.
- Use a metal shield to protect the load cells from radiant heat sources. Use an insulating pad between the vessel and load cell mount if heat is being conducted.
- If thermal expansion/contraction of the vessel is expected, choose a mount which will allow unhindered lateral movement. If stay rods are required, position them so that thermally induced movement is minimized. See [Section 20.0 on page 80](#) for more information.
- Place the vessel indoors, if possible, where it will be protected from wind and drafts.
- Do not place the vessel in an environment where its support structure is subject to vibration. Ensure that vibrations are not transmitted via attached piping or stay rods.
- Select load cells and mounts that will give the degree of corrosion protection required.
- Use load cells that have the degree of environmental protection required for the application. For example, avoid possible moisture problems with standard load cells in washdown applications by specifying hermetically sealed cells.

13.2 Load Cell and Mount

- Choose load cells with accuracy that is consistent with the desired system accuracy.
- Do not grossly oversize the load cells; see [Section 14.2 on page 54](#). The best accuracy will be achieved when weighing loads close to the vessel capacity. As a general rule, do not attempt to weigh a load of less than 20 graduations.
- Support the vessel entirely on load cells; do not use dummy cells or flexures that would hinder a good calibration.
- Use proven load cell mounts that will provide optimal loading conditions.
- Orient the mounts as recommended in the installation manual.

13.3 Mechanical/Structural Considerations

- Support the load cell mounts on a rigid structure; this will ensure a high natural frequency and reduce the amount of bounce and instability. All support points must be equally rigid to avoid tipping of the vessel as load is applied.
- Minimize interaction between adjacent weigh vessels mounted on the same structure.
- Vehicular traffic must not cause deflection of the vessel's support structure.
- Ladders, pipes and check rods, etc. should not be allowed to shunt the weight that should rest on the load cells.
- Where piping or conduit must be attached to the vessel, use the smallest diameter acceptable for the application. Use the longest unsupported horizontal length of pipe possible to connect to the vessel.
- Use an indicator that is EMI/RFI protected. Provide grounding and transient protection in accordance with the manufacturer's recommendations. In general, take measures to reduce electrical interference.
- Use a good-quality junction box which remains stable with changing temperatures. Look for a junction board which has a solder mask at a minimum and which preferably is with a conformal coating also. Ensure that the enclosure is suited to the environment.

13.4 Calibration

- Hang weights off the corners of the vessel to trim the load cell outputs when calibrating. Use weights as described above, or known weight of material to perform the calibration. See [Section 25.0 on page 94](#).

13.5 Operational Considerations

- Maintain an even and consistent flow of material.
- Avoid simultaneous fill/discharge of weigh vessel.
- Slow down the filling cycle as much as possible and/or use a two-speed fill cycle.
- Reduce to a minimum the amount of "in flight" material.
- Use preact learning to predict the optimum cutoff point based on past performance.
- Use Auto Jog to top off contents after fill.
- If possible, switch off any vibrating or mixing equipment while the weight is being determined.
- Reduce to a minimum the surging of liquids while a weight reading is being taken.

14.0 Selecting the Number of Supports and Load Cell Capacity

14.1 Number of Supports

The number of supports to be recommended is dependent on the geometry, gross weight, structural strength and stability of the vessel. The number of supports chosen for a vessel influences the capacity of the load cells required. In general, no more than eight supports should be used. It becomes more difficult to get even weight distribution on all supports as the number increases beyond three. Below is a look at a number of examples.

14.1.1 Suspended Vessels

These vessels are very often suspended from an existing structure which will sometimes dictate how many supports will be used. In general, one or more supports may be used. Using three supports or fewer has the advantage of not requiring adjustment of the length of the support linkages to distribute the load equally between all supports (assuming the cells are arranged symmetrically on the vessel).

14.1.2 Upright Cylindrical Vessels in Compression

The most convenient method of mounting is with three supports arranged at 120° intervals. Correct weight distribution is inherent to three-point support and is preferred whenever possible. With tall slender vessels or vessels subject to fluid sloshing, wind or seismic loads, stability against tipping becomes a consideration. In these situations, four or more supports should be considered. See [Section 17.0 on page 65](#).

14.1.3 Square, Rectangular or Horizontal Cylindrical Vessels Mounted in Compression

Because of geometry, it is usually most convenient to mount these vessels on four supports, close to each corner. Higher capacities may require more than four.

14.2 Load Cell Capacity

It is vital to the performance of a weighing system to select load cells of the correct capacity. Here are some guidelines:

- All load cells selected must be of the same capacity and mV output. It is recommended to use the same model and capacity load cells.
- Estimate the vessel dead weight, including all piping, pumps, agitators, insulation and vessel heating fluids.
- Add the maximum live weight of product to be weighed to the dead weight. This is the gross weight of the vessel and contents.
- Divide the gross weight by the number of legs or support points. This is the nominal weight which will be carried by each load cell.
- Select a load cell with a capacity somewhat greater than the nominal weight. The following should be considered when determining how much greater the load cell capacity should be:
 - Is the dead weight accurate?
 - Will the load be evenly distributed on all cells?
 - Is the vessel fitted with an agitator or subjected to shock loading?
 - Is it possible the vessel will be overfilled, exceeding the live weight value?
 - Will the vessel be subjected to wind or seismic loading? For more information, see [Section 17.0 on page 65](#).

A good rule is to select a load cell with a capacity 25 to 50% in excess of the calculated nominal load per cell. Once the load cell capacity has been determined, check that the live weight signal is adequate for the instrumentation selected. See [Section 21.0 on page 84](#) for information on how to determine this for the system. This is particularly important when the ratio of dead weight to live weight is high.

Additional factors to consider:

- Load Cell Construction Material—In a corrosive environment, painted load cells offer premium protection, while stainless steel outperforms nickel-plated alloy steel.
- Load Cell Protection—The ultimate degree of moisture ingress protection can be achieved with hermetically sealed load cells which ensure the integrity of the strain gauge section of the cell in washdown applications.
- Cable Length—Check that the standard cable length will be adequate for the installation. Longer cable lengths are available on special order in some cases.

15.0 Calculating Thermal Expansion of Vessels and Stay Rods

15.1 Stay Rod Expansion/Contraction

Stay rods attached to vessels subjected to thermal changes can introduce significant forces which affect system accuracy. The method of attachment and the length of the stay rods directly affect these forces.

Figure 15-1 illustrates a stay rod rigidly attached to a bracket on each end—one bracket is rigidly mounted, the other is unattached, thus allowing the rod to expand and contract freely. As the temperature rises or drops, the length of the rod will increase or decrease respectively. The change in length (ΔL) is proportional to the original length (L), the change in temperature (ΔT), and the coefficient of linear expansion (α) which is a characteristic of the rod material.

ΔL can be calculated from the following equation:

$$\Delta L = \alpha \times L \times \Delta T$$

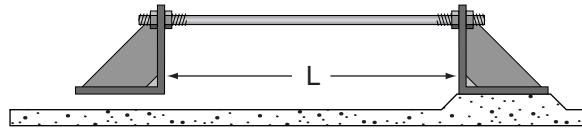

Figure 15-1. Stay Rod

The coefficient of thermal expansion (α) for various materials is used to construct vessels and stay rods.

Material		Coefficient of Linear Expansion (mm per °C)
Steel	Low Carbon (1018)	12.0×10^{-6}
Stainless Steel	302	17.3×10^{-6}
	303	
	304	
	316	16.0×10^{-6}
Aluminum	6061	24.0×10^{-6}

Table 15-1. Thermal Expansion Coefficients

Example:

If the rod in Figure 15-2 is made from 1018 steel, then $\alpha = 12.0 \times 10^{-6}$. If the rod is 48 in long and the temperature increases by 60°F, the length of the rod will increase by:

$$\Delta L = \alpha \times L \times \Delta T$$

$$\Delta L = 12.0 \times 10^{-6} \times 48 \times 60$$

$$\Delta L = 0.019 \text{ in}$$

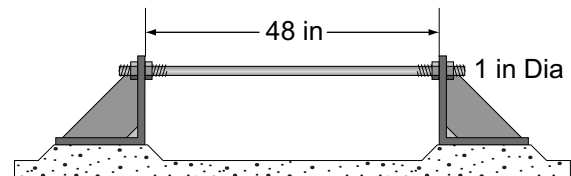

Figure 15-2. Stay Rod

This shows that a 48 in steel rod will increase by 0.019 in as a result of a 60°F temperature rise. This may seem insignificant, until considering the forces which can result if the stay rod is confined rigidly at each end, as in Figure 15-2.

In Figure 15-2, a 1 in steel rod 48 in long is attached to a bracket on each end, and both brackets are rigidly attached. If the rod is initially adjusted so that there is no strain, a subsequent 60°F rise in temperature will cause the rod to exert a force of 9,000 lb on each bracket. Therefore, vessel restraint systems must be designed and installed properly so that they don't move and/or apply large lateral forces to the weigh vessel.

15.2 Vessel Expansion/Contraction

Temperature fluctuations will cause weigh vessels to grow and contract. [Figure 15-3](#) illustrate this.

Rectangular Vessel Example

Shown is a top view of a rectangular vessel. The solid line represents its size at 70°F and the inner and outer broken lines represent its size at 40°F and 100°F respectively. The amount that the sides will increase/decrease in length can be found using the expansion formula discussed previously.

$$\text{Therefore: } \Delta L = \alpha \times L \times \Delta T$$

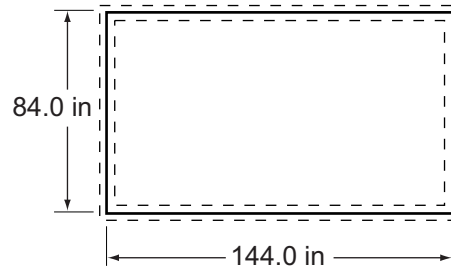

Figure 15-3. Weigh Vessel Expansion/Contraction

If the vessel is made from mild steel, the length will vary by ± 0.028 in ($6.5 \times 10^{-6} \times 144 \times 30$), and the width will vary by ± 0.016 in ($6.5 \times 10^{-6} \times 84 \times 30$) as the temperature fluctuates by $\pm 30^\circ\text{F}$. It will be apparent that if the load cell is held rigidly by the mount, enormous side forces will be applied to the cell, hence the need to use a mount which can accommodate vessel expansion/contraction due to changes in temperature.

Cylindrical Vessel Example

In the case of a cylindrical vessel [Figure 15-4](#), the change in diameter (ΔD) resulting from a change in temperature (ΔT) is given by:

$$\Delta D = \alpha \times D \times \Delta T$$

If a cylindrical vessel is 96 inches in diameter and made from 304 stainless steel and is subjected to a temperature rise of 80°F as the result of being filled with a hot liquid, then the diameter will increase by:

$$\begin{aligned} \Delta D &= 9.6 \times 10^{-6} \times 96 \times 80 \\ &= 0.074 \text{ in} \end{aligned}$$

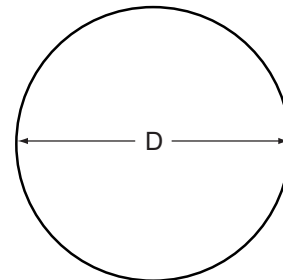

Figure 15-4. Cylindrical Vessel

Vessels with attached piping can be subjected to severe side forces as a result of temperature variations if the connections are not executed properly. It is worth noting that vessels expand and contract vertically as well as horizontally with changes in temperature. Rigidly-attached piping may magnify the effects of this expansion, as seen in [Figure 15-5](#). See [Attaching Piping to Weigh Vessels in Section 18.0 on page 72](#) for detailed guidelines on this subject.

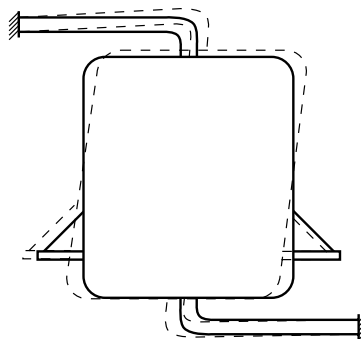
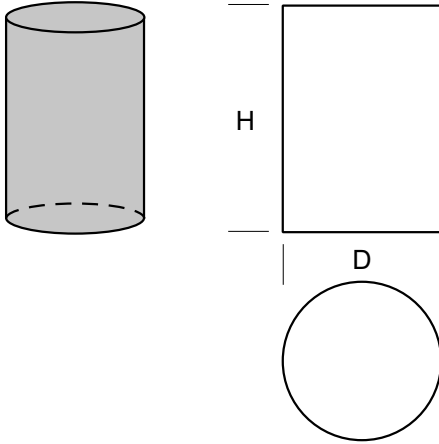

Figure 15-5. Weigh Vessel with Rigidly-Attached Piping

16.0 Calculating Tank Volumes

16.1 Formulas for Tank Shapes and Sections

16.1.1 Cylinder



$$\text{Volume} = \frac{\pi}{4} D^2 H$$

16.1.2 Portion of Cylinder

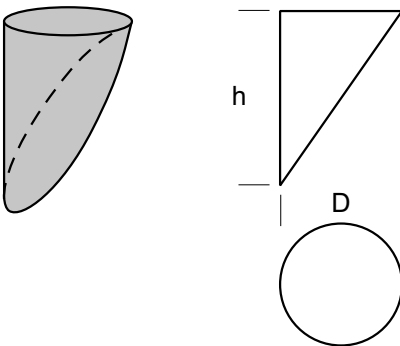

$$\text{Volume} = \frac{\pi}{8} h D^2$$

16.1.3 Horizontal Cylinder (Partially Filled)

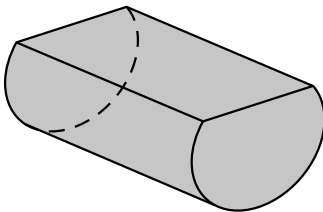

$$\text{Volume} = \frac{\pi}{4} D^2 L - \left[\frac{\pi}{720} D^2 L \cos^{-1} \frac{(2h - D)}{D} + \left(h - \frac{D}{2} \right) L \sqrt{hD - h^2} \right]$$

If the vessel is filled completely ($h = D$), then this formula reduces to:

$$\text{Volume} = \frac{\pi}{4} D^2 L$$

If the vessel is filled half way ($h = D/2$), then this formula reduces to:

$$\text{Volume} = \frac{\pi}{8} D^2 L$$

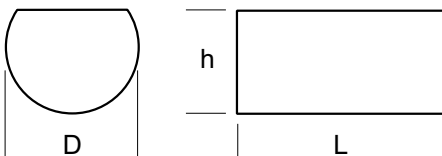

16.1.4 Frustum of Cone

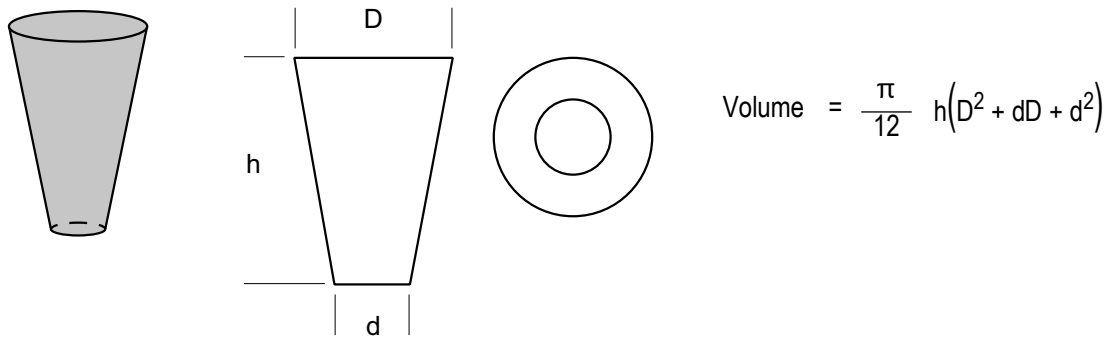

16.1.5 Hemispherical End

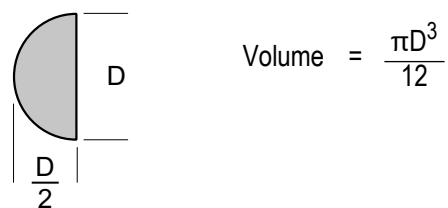

16.1.6 Spherical Segment

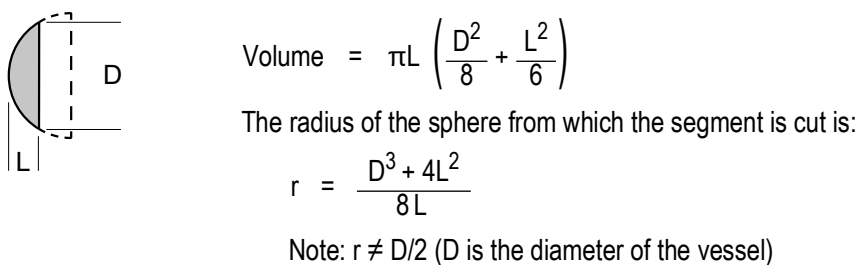

16.1.7 Hemispherical End (Partially Filled)

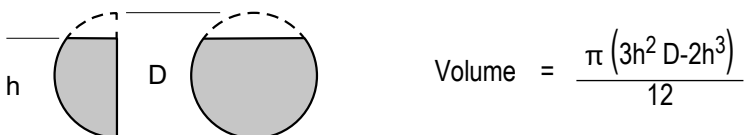

16.1.8 Square Prism (Rectangular Cross Section)

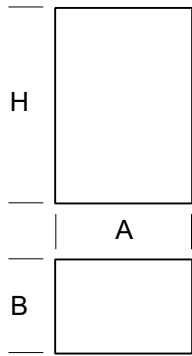
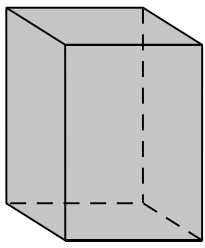

$$\text{Volume} = ABH$$

16.1.9 Square Prism (Square Cross Section)

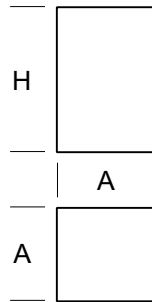
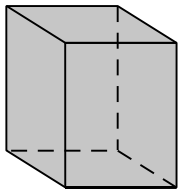

$$\text{Volume} = A^2H$$

16.1.10 Wedge I

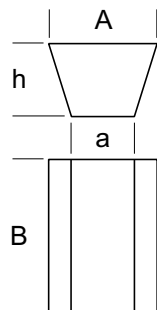
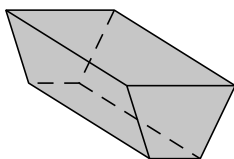

$$\text{Volume} = \left(\frac{a+A}{2} \right) Bh$$

16.1.11 Wedge II

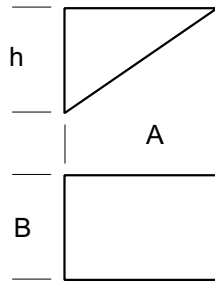
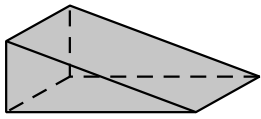

$$\text{Volume} = \frac{hAB}{2}$$

16.1.12 Frustum of Pyramid

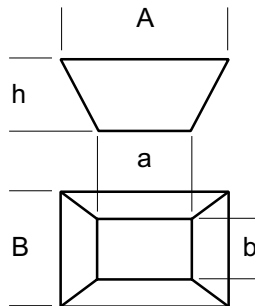
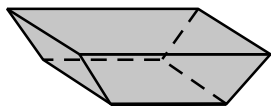

$$\text{Volume} = \frac{h}{6} (2AB + Ab + aB + 2ab)$$

16.2 Angle of Repose

When a granular material is dropped from above onto a flat surface it tends to form a cone. The shape of this cone is described by the angle of repose (α), which is a characteristic of the material. The angle of repose varies somewhat with particle size, moisture content, etc. The relationship between α , h , and D is:

$$\text{Volume} = \frac{D^2 \tan \alpha}{2}$$

The volume of any cone is:

$$\frac{\text{height}}{3} \times \text{area of base}$$

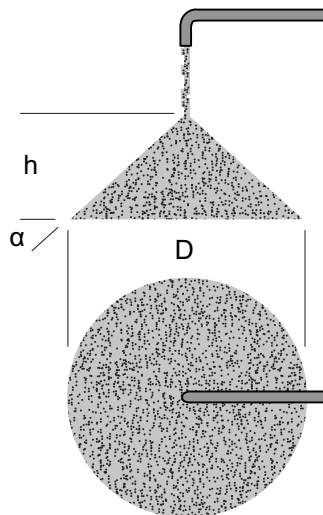

Angle of Repose Calculation Example

In calculating the volume of material in a vessel, an adequate approximation can be made by adding 1/3 of the height of the cone to the height of material up to the cone.

For example, assume the height of the material in the cylindrical vessel to be 15 ft + 1.666 ft = 16.666 feet.

The volume is calculated using the following formula:

$$\text{Volume} = \frac{\pi}{4} D^2 h = \frac{3.14}{4} \times (10)^2 \times 16.666 = 1308.28 \text{ cubic feet}$$

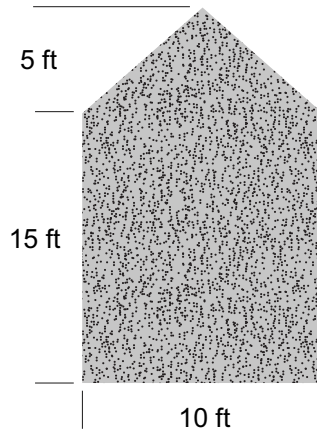

16.3 Calculation Examples

Example 1

Calculate the volume of liquid in the horizontal tanks shown below. It has hemispherical ends and is filled to a height of 4.5 ft.

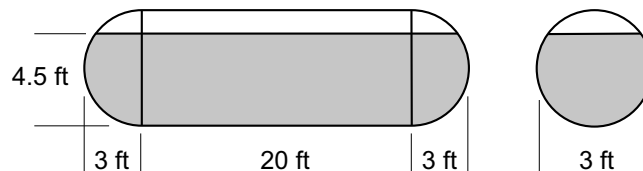

For ease of calculation, this can be broken into 3 sections:



Step 1

The volume of section (a) or (c) is given by formula:

$$\text{Volume} = \frac{\pi}{12} (3h^2D - 2h^3)$$

Where $\pi = 3.14$, $h = 4.5$, $D = 6$

$$\begin{aligned} \text{Volume} &= \frac{3.14}{12} [(3 \times 4.5^2 \times 6) - (2 \times 4.5^3)] \\ &= \frac{3.14}{12} (182.25) \\ &= 47.7 \text{ cu ft} \end{aligned}$$

Step 2

The volume of (b) is given by the formula:

$$\text{Volume} = \frac{\pi}{4} D^2 L - \left[\frac{\pi}{720} D^2 L \cos^{-1} \frac{(2h - D)}{D} + \left(h - \frac{D}{2} \right) L \sqrt{hD - h^2} \right]$$

Where $\pi = 3.14$, $h = 4.5$, $D = 6$, $L = 20$

$$\begin{aligned} \text{Volume} &= \frac{3.14 \times 6^2 \times 20}{4} - \left[\frac{3.14 \times 6^2 \times 20 \cos^{-1} \left(\frac{2 \times 4.5 - 6}{6} \right) + \left(4.5 - \frac{6}{2} \right) 20 \sqrt{4.5 \times 6 - 4.5^2}}{720} \right] \\ &= 565.2 - [3.14 \cos^{-1}(0.5) + 30 \sqrt{6.75}] \\ &= 565.2 - [188.4 + 77.94] \\ &= 454.7 \text{ cu ft} \end{aligned}$$

Step 3

Total Volume = Volume (a) + Volume (b) + Volume (c)

$$\begin{aligned} &= 47.7 + 454.7 + 47.7 \\ &= 550.1 \text{ cu ft} \end{aligned}$$

Example 2

If, in the last example, the vessel were filled completely, then the volume would be:

Total Volume = Volume (a) + Volume (b) + Volume (c)

$$\begin{aligned} \text{Volume} &= \frac{\pi D^3}{12} + \frac{\pi D^2 L}{4} + \frac{\pi D^3}{12} \\ &= \frac{3.14(6^3)}{12} + \frac{3.14(6^2) \times 20}{4} + \frac{3.14(6^3)}{12} \\ &= 56.5 + 565.2 + 56.5 \\ &= 678.2 \text{ cu ft} \end{aligned}$$

Example 3

If the vessel in Example 2 is filled with linseed oil, calculate the weight of material when the vessel is full.

The density of linseed oil is 2066 lb/cu ft. From Example 2, we know that the volume of the vessel is 678.2 cu ft.

$$\text{Weight of Material} = \text{Volume} \times \text{Density}$$

$$\text{Weight of Material} = 678.2 \times 2066$$

$$\text{Weight of Material} = 39,675 \text{ lb}$$

Example 4

Calculate the volume of material in the hopper shown below:

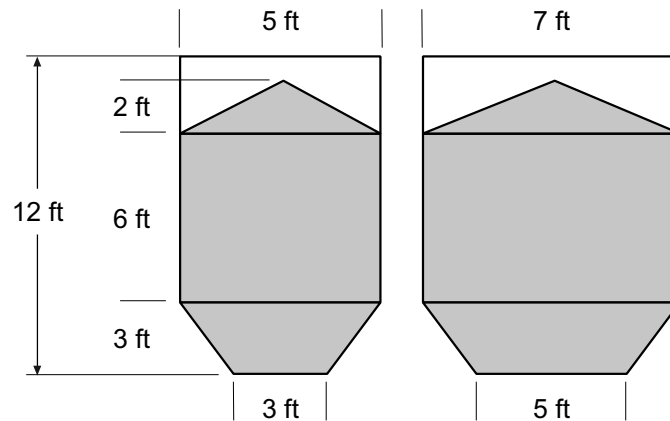

The calculation steps for this example are on the next page.

For ease of calculation, this may be broken into 2 sections as follows:

Step 1

The volume of section (a) is given by:

$$\begin{aligned} \text{Volume} &= ABh \\ &= 5 \times 7 \times 6.7 \\ &= 234.5 \text{ cu ft} \end{aligned}$$

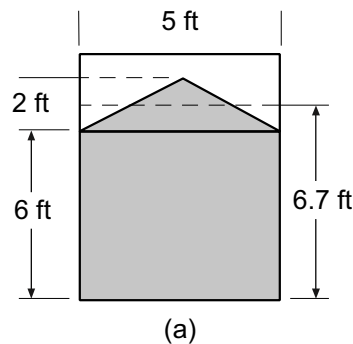

Where leveled height is assumed to be 6.7 ft.

Step 2

The volume of section (b) is given by:

$$\begin{aligned} \text{Volume} &= \frac{h}{6} (2AB + Ab + aB + 2ab) \\ \text{Volume} &= \frac{3}{6} [(2 \times 5 \times 7) + (5 \times 5) + (3 \times 7) + (2 \times 3 \times 5)] \\ &= \frac{3}{6} (146) \\ &= 73.0 \text{ cu ft} \end{aligned}$$

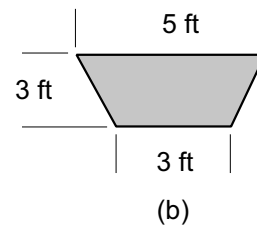

Step 3

$$\begin{aligned} \text{Total Volume} &= \text{Volume (a)} + \text{Volume (b)} \\ &= 234.5 + 73.0 \\ &= 307.5 \text{ cu ft} \end{aligned}$$

Example 5

If, in the last example, the vessel was filled to overflowing, then the volume would be:

$$\text{Total Volume} = \text{Volume (a)} + \text{Volume (b)}$$

Volume (b) = 73.0 cu ft (same as the previous example)

Volume (a) = $5 \times 7 \times 9.7 = 339.5$ cu ft

$$\begin{aligned} \text{Total Volume} &= 339.5 + 73.0 \\ &= 412.5 \text{ cu ft} \end{aligned}$$

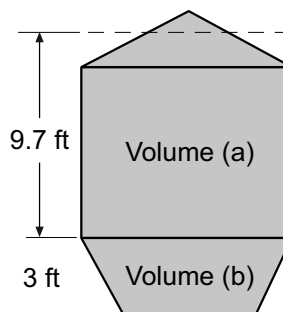

17.0 Wind and Seismic Effects on Vessel Stability

17.1 Overview

Other than forces resulting from the impact of a vehicle, wind and seismic forces are the most important external forces which might affect a weigh vessel. The threat from vehicular traffic can be guarded against using properly designed guard rails. The effects of wind and seismic forces, where they are a factor, must be accounted for in the design of a weigh vessel. At a minimum, consideration of these forces might affect the capacity of load cells selected. In more extreme cases they may dictate the use of additional restraints on a vessel. Please reference the specific weigh module specifications for the lift-off and side-load ratings.

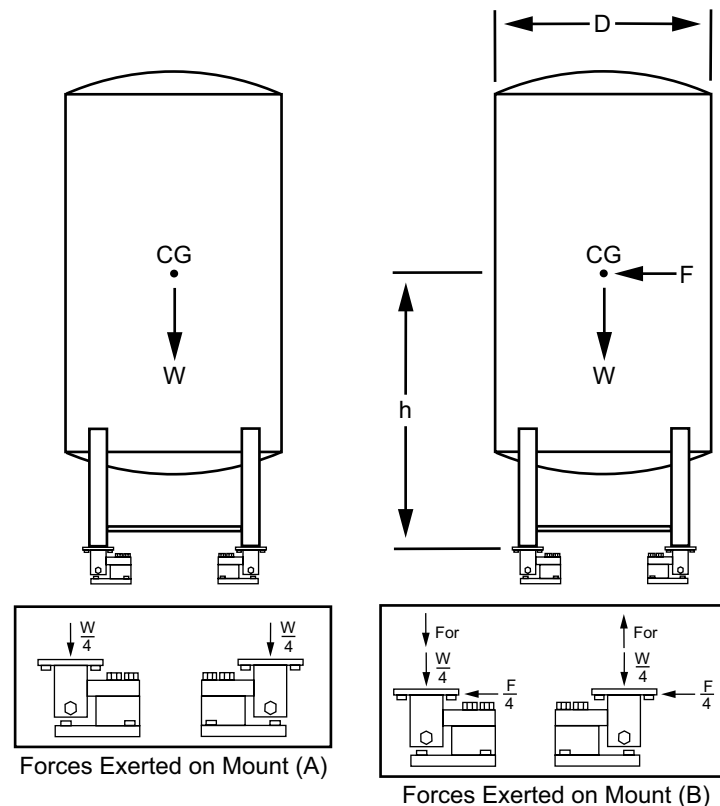

Figure 17-1. External Forces on a Weigh Vessel

In general, these forces act horizontally at the center of gravity (CG) of the weigh vessel. [Figure 17-1-A](#) illustrates a four-legged vertical cylindrical vessel and the forces acting on it in the absence of wind or seismic forces. W is the vessel's weight (an empty and full vessel should be considered separately, as either one may be the limiting case), and it acts through the vessel's center of gravity. Assuming that the four legs are arranged symmetrically, then each leg will exert a force of $1/4W$ on each mount.

[Figure 17-1-B](#) illustrates the same vessel with the addition of a horizontal force F (the result of wind or seismic activity). The vessel exerts a horizontal force of $1/4F$ on each load cell mount. Also, there is an additional force of F_{0T} acting on the left-hand side load cell mounts, which means that each is now carrying a load of $1/4W + F_{0T}$. On the right-hand side load cell mounts, a force of F_{0T} is also induced as a result of F , however, this force is in the opposite direction to the existing $1/4W$ and the total force here is reduced to $1/4W - F_{0T}$. Therefore, the load is being transferred from the mounts on one side of the vessel to those on the other. The load cell capacity selected must be capable of withstanding this additional force for the extremes of wind or seismic forces expected. If F was increased to where F_{0T} equaled $W/4$ then there would be zero load on the right hand mounts and the load would have doubled to $W/2$ on the left-hand mounts. Further increase in F will cause the vessel to lift up on the right-hand mounts and may, in the extreme case, cause the vessel to tip.

The relationship between F_{0T} and F may be stated as follows for the vessel shown in Figure 17-1:

$$F_{0T} = 0.7 Fh/D$$

Where h = height to the center of gravity and D = vessel diameter.

It is desirable to reduce F_{0T} ; this can be done by reducing F or h or by increasing D . Dimension h can be reduced by reducing the vessel height (not always practical) or by placing the mounts at the vessel's center of gravity as illustrated earlier. In this case $h = 0$ and hence $F_{0T} = 0$.

It is interesting to compare the stability of a vessel supported on 3 and 4 load cell mounts. Figure 17-2 shows a top view of a vertical cylindrical vessel supported at 3 and 4 points (broken and solid lines respectively). The vessel will tend to tip about a straight line drawn between adjacent support points; the greater the distance from the center of gravity to this line the more stable the vessel will be. A vessel supported at 3 points will be approximately 29% less stable than if it were supported at 4 points.

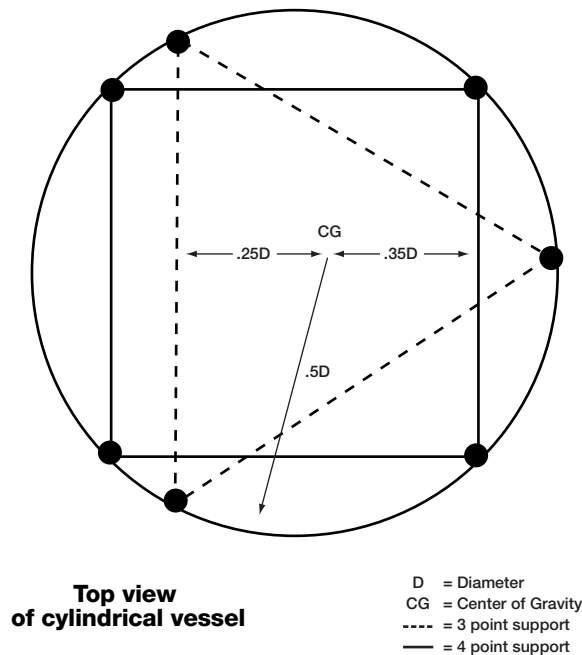

Figure 17-2. Vertical Cylindrical Vessel Top View

Because of the many variables in vessel design and site conditions, it is impossible to deal comprehensively with the calculation of wind and seismic forces in this text. However, the following subsections deal with these forces in general terms and point out the information necessary for a complete analysis. Refer to the International Building Code (IBC) for more information.

While the effects of both wind and seismic forces should be considered, it is acceptable to consider these forces in isolation.

17.2 Wind and Seismic Weigh Module Policy

Wind and seismic forces are external forces that may affect a weigh vessel and are substantial considerations when designing a vessel weighing application. With tall, slender vessels, or vessels subject to wind or seismic loads, stability becomes a primary concern.

A structural engineer is required to ensure the vessel and mounts are properly sized and designed for the specific location's likelihood of damage due to wind and seismic forces. There are many variables to consider when determining if a system is structurally sound, examples include the geological make-up of the application site and the vessel's foundation design.

The effects of wind and seismic forces must be accounted for in the design of a weigh vessel on an individual installation basis. Although load cell capacity and the use of additional vessel restraints may be part of the preventative design, site conditions and the extent of wind and seismic forces for the geographic location must also be thoroughly reviewed. Because of the many variables in vessel loading, it is Rice Lake Weighing Systems' policy to encourage you to follow best practices and review vessel weighing applications with a licensed structural engineer who is familiar with wind and seismic forces.

Upon request, Rice Lake Weighing Systems can provide individual load cell/weigh module load ratings for downward loads, upward (uplift) loads and side (shear) loads. If you have any questions about wind and/or seismic forces and how they affect your vessel weighing application, please feel free to contact Rice Lake's engineering department at 800-472-6703.

17.3 Wind Forces

NOTE: This section refers to the *International Building Code (IBC)* for a conceptual explanation of wind forces. Always refer to the local building code for site specific wind force calculations.

Consideration must be given to the effects of wind loading when a weigh vessel is installed outdoors. This is particularly important for tall slender vessels, vessels installed in exposed locations (for example, facing a large body of water), or those installed in a high wind-speed location. In analyzing the effects of wind loading, it must be assumed that the wind may blow at a vessel in any horizontal direction.

Figure 17-3 illustrates the effect of wind blowing at a vertical cylindrical vessel. Note that not only is there a force exerted against the windward side of the vessel, but there is also a suction force on the leeward side. These forces are additive, and tend to tip the vessel in the direction of the wind. At right angles to the wind direction are suction forces pulling on each side due to the increased speed of the wind at these points. Since these are equal and opposite in direction, they have no net effect on the stability of the vessel.

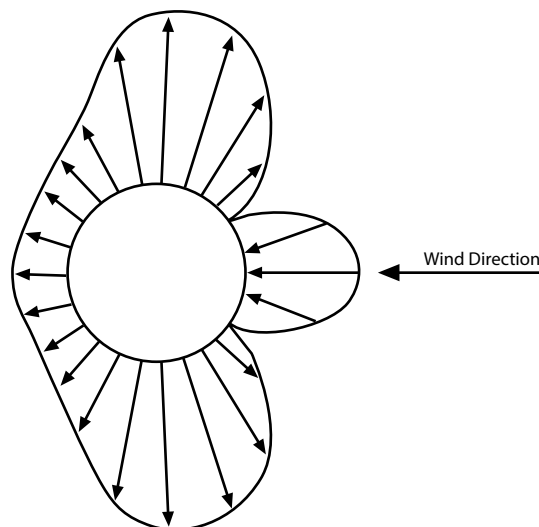

Figure 17-3. Wind Forces on a Vertical Cylindrical Vessel

To perform a complete wind force analysis, the following information is necessary:

- Vessel: The vessel's dead and live weights, number of supports and overall dimensions such as height, length of legs, diameter, etc.
- Minimum basic wind speed: Refer to local standards.
- Exposure: The exposure conditions at the site must be known. Built up or rough terrain can cause a substantial reduction in wind speed. The International Building Code (IBC) defines three exposure categories:
 - Exposure B: Has terrain with buildings, forest or surface irregularities 20 feet or more in height covering at least 20% of the area extending one mile or more from the site.
 - Exposure C: Terrain is flat and generally open, extending one half mile or more from the site in any full quadrant.
 - Exposure D: Represents the most severe exposure in areas with basic wind speeds of 80 mph or greater and has terrain which is flat and unobstructed facing large bodies of water over one mile or more in width relative to any quadrant of the vessel site. Exposure D extends inland from the shoreline 1/4 mile or 10 times the vessel height, whichever is greater.
- Importance Factor: An importance factor of 1.15 is used for essential facilities which must be safe and usable for emergency purposes after a windstorm in order to preserve the health and safety of the general public. Such facilities include medical facilities having surgery or emergency treatment areas, fire and police stations. A factor of 1.0 is used for all other facilities.

With this information, the wind forces can be calculated in accordance with methods described in the IBC. This information may be used to verify the stability of the vessel using standard mounts, or to design additional restraints if deemed necessary.

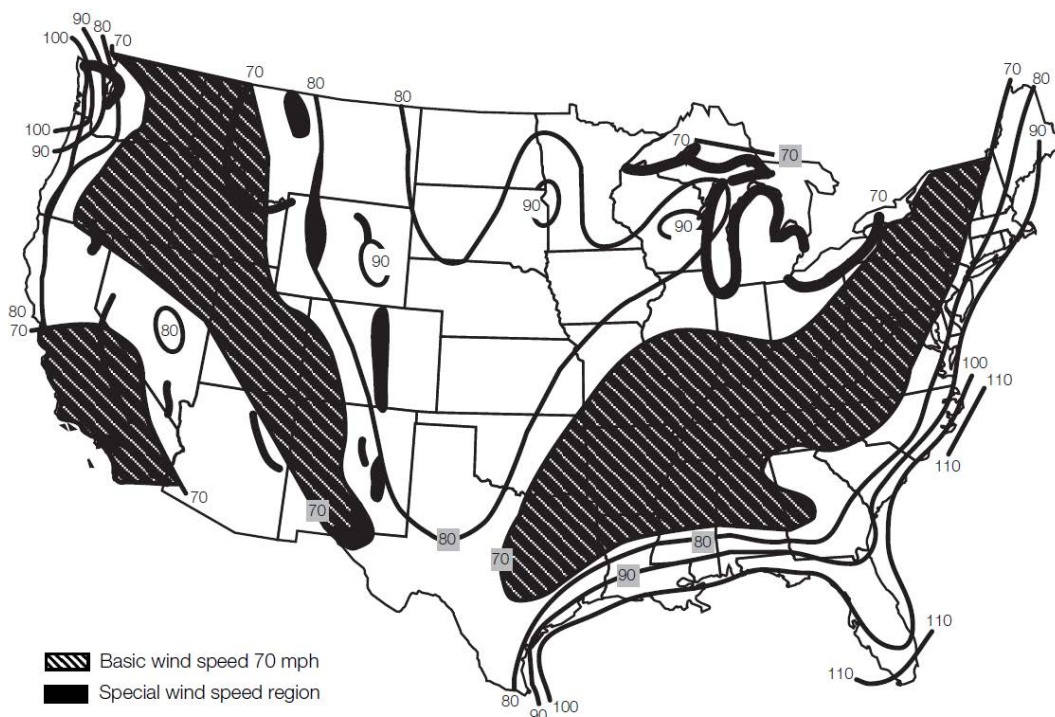

Figure 17-4. Wind Speed Contours Map

- Values are fastest mile speeds at 33 feet above ground for Exposure Category C and are associated with an annual probability of 0.02.
- Linear interpolation between wind speed contours is acceptable.
- Caution in use of wind speed contours in mountainous regions of Alaska is advised.
- Wind speed for Hawaii is 80 and Puerto Rico is 95.
- Wind speed for Alaska varies from 70 inland to over 110 in coastal areas.
- Where local records or terrain indicate higher 50-year wind speeds, they shall be used.
- Wind speed may be assumed to be constant between the coastline and the nearest inland contour.

17.4 Seismic Forces

NOTE: This section refers to the International Building Code (IBC) for a conceptual explanation of seismic forces. Always refer to the local building code for site specific seismic force calculations. A structural engineer and geologist will need to examine vessel design and site location to determine the correct capacity of load cells to be used.

In the International Building Code (IBC), seismic zones are numbered 0 (little likelihood of damage) through 4 (likelihood of major damage) which indicate, on an ascending scale, the severity of damage likely as the result of earthquakes. The effects of seismic forces should be considered on vessels being installed in zones 1 through 4.

The following information is required in order to perform a complete seismic analysis.

- Vessel: The vessel's dead and live weights, number of supports and overall dimensions such as height, length of legs, diameter, etc.
- The seismic zone in which the vessel will be installed.
- Is the vessel freestanding, mounted on a structure or on the roof of a building?
- Function of structure. Does the vessel:
 - Contain material or equipment necessary for the protection of essential facilities (hospitals, fire and police stations), hazardous facilities or special occupancy structures (schools, jails and public utilities)?
 - Contain sufficient quantities of toxic or explosive substances to be dangerous to the safety of the general public if released?
 - Support the operation of public utility facilities?
 - Perform a function not listed above.
- Site geology/soil characteristics and the vessel's structural period, if available.

With this information, the forces resulting from seismic activity can be calculated according to methods described in the International Building Code (IBC).

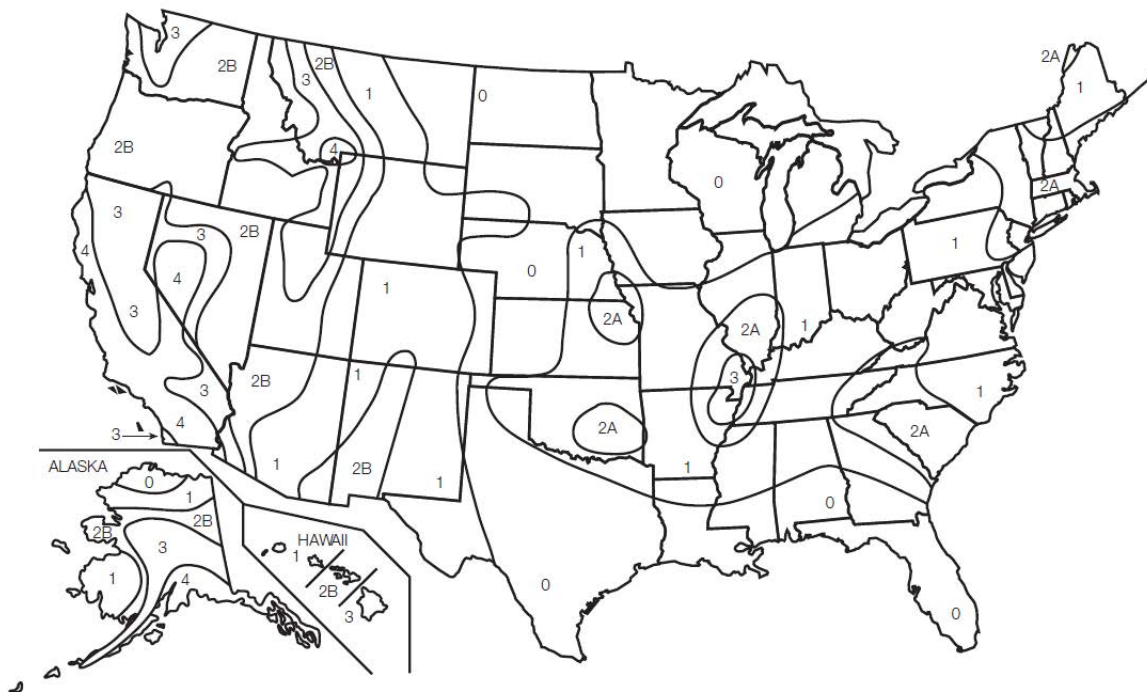

Figure 17-5. Seismic Zone Map

This Page Intentionally Blank.

Vessel Attachments

18.0	Attaching Piping to Weigh Vessels	72
18.1	Example 1	73
18.2	Example 2	75
19.0	Piping Guidelines	77
20.0	Vessel Restraint Systems	80
20.1	Stay Rods	80
20.2	Safety Check Rods	81

18.0 Attaching Piping to Weigh Vessels

Attached piping is by far the largest source of error in vessel weighing; therefore, the piping arrangement must be carefully planned in the design of any weigh vessel.

Figure 18-1 shows a vessel mounted on load cells and supported on an I-beam structure. An attached horizontal pipe is rigidly supported a distance “ l ” from the vessel.

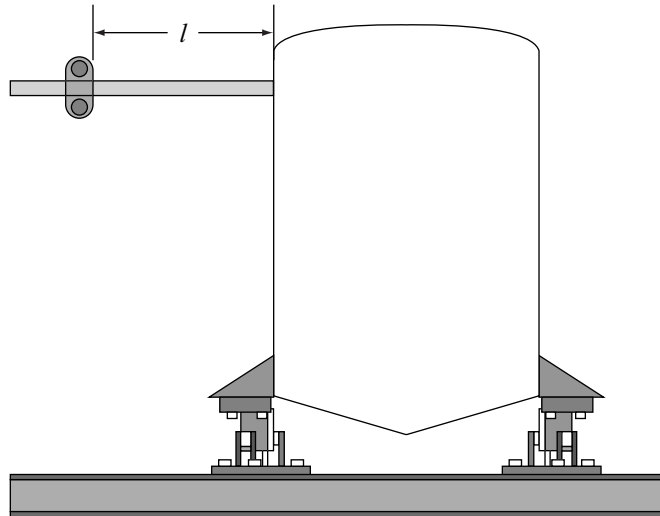

Figure 18-1. Vessel Application

When the vessel is loaded, it moves downward as shown in Figure 18-2 as a result of:

- The deflection of the load cell, 0.005 to 0.015 in at full load
- The deflection of the support structure

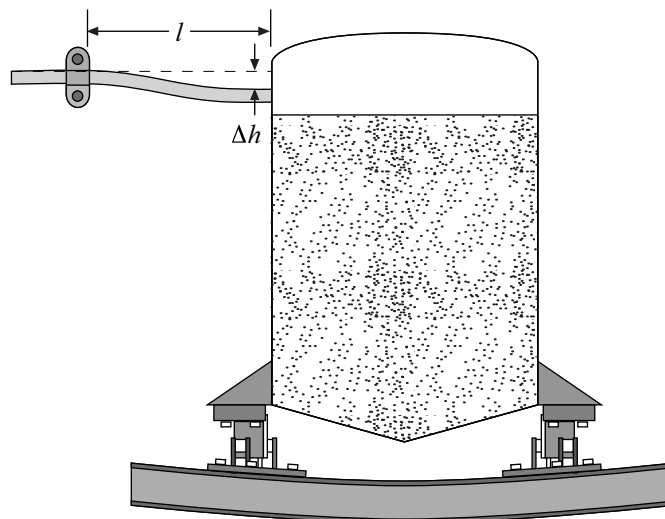

Figure 18-2. Deflection of Vessel Application

The attached pipe also deflects downward by the same amount Δh and it applies an upward force to the tank.

The effects of piping are particularly severe when several pipes are attached to a low-capacity weigh vessel. Through proper design, the upward forces exerted by the pipes can be reduced to a small percentage of the vessel's live load. Then, by calibrating the vessel with weight, the remaining effects can be compensated for. Calibration using a load cell simulator will not produce accurate results, since there is no way to simulate the effects of attached piping.

Some common rules for piping design are as follows:

- Reduce deflection of the vessel support structure to a minimum.
- Use the smallest diameter and lightest wall pipe possible.
- All pipes must run horizontally away from the vessel.
- Place the first pipe support 20 to 30 times the pipe diameter away from the vessel.

Example: For a 2 in diameter pipe, place the first support at least 40 in (preferably 60 in), away from vessel.



NOTE: Pipe diameters and wall thickness, pipe support intervals, etc., must be chosen consistent with the functionality, structural and reliability requirements of the system in addition to recommendations of this section.

For a more rigorous treatment of the subject, the force F_1 exerted on the vessel may be calculated using the following equation:

$$F_1 = \frac{0.59(D^4 - d^4) \times (\Delta h) \times E}{l^3}$$

Where:

For Imperial Examples

D = outside diameter of pipe (inches)

d = inside diameter of pipe (inches)

Δh = total deflection of the pipe at the vessel, relative to the fixed point

E = Young's modulus

= 29,000,000 for mild steel

= 28,000,000 for stainless steel

= 10,000,000 for aluminum

l = length of pipe from vessel to first support point

Where:

This yields conservative results, since it assumes that the pipe is held rigidly at both ends. In practice there will be some give in both the support point and its attachment to the vessel. The following example illustrates the use of this formula.

18.1 Example 1

A steel tank is supported on load cells and a steel structure with deflections of 0.008 in and 0.250 in respectively under load. A 4 in schedule 40 pipe is attached horizontally with 36 in free span between the vessel and the first support point. What force F_1 is exerted upward on the vessel?

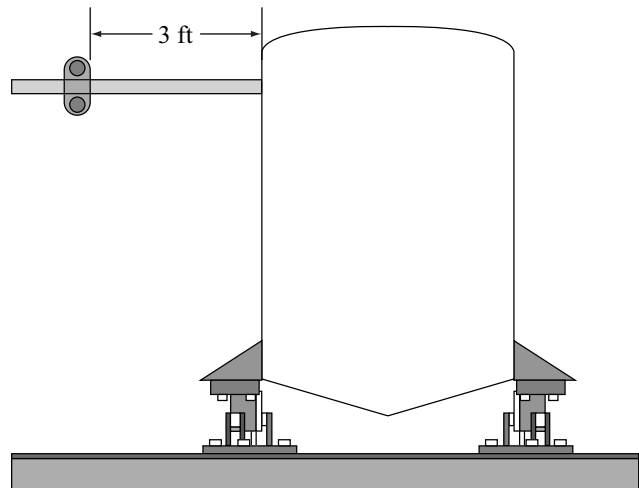

From the above information:

$$\Delta h = 0.008 \text{ in} + 0.250 \text{ in} = 0.258 \text{ in}$$

$$E \text{ (mild steel)} = 29,000,000$$

$$D = 4.50, d = 4.03 \text{ (For schedule 40 pipe)}$$

$$l = 36 \text{ in}$$

Hence:

$$F_1 = \frac{0.59(4.50^4 - 4.03^4) \times (0.258) \times 29,000,000}{36^3}$$

$$= 13,840 \text{ lb}$$

Example	Pipe	Pipe Length (l)	Deflection (Δh)	Upward Force (F_1)	Percentage Reduction in (F_1)
1	4 in schedule 40	36 in	0.258	13,840	-
2	4 in schedule 40	72 in	0.258	1,730	87%
3	4 in schedule 40	36 in	0.133	7,130	50%
4	4 in schedule 10S*	36 in	0.258	7,630	45%
5	2 in schedule 40†	36 in	0.258	976	93%

* For 4 in Schedule 10S, D=4.50, d=4.26; † For 2 in Schedule 40, D=2.38; d=2.16

Table 18-1. Metric Examples

- **Example 1** summarizes the above result. The other lines (**Examples 2–5**) represent the result when one parameter is changed. The last column on the right expresses the percent change in F_1 relative to Example 1 (13,840 lb).
- **Example 2** shows the effect of doubling the length of pipe between the vessel and first support point. The 87% reduction shows that F_1 can be greatly decreased by increasing the distance to the first support point.
- **Example 3** shows the effect of cutting the structural deflection in half from 0.250 to 0.125 in (the load cell deflection of 0.008 in remains the same). It is obvious from the 50% reduction that F_1 can be moderately decreased by reducing the vessel's deflection.
- **Example 4** shows the effect of using a lighter-wall schedule 10S pipe instead of schedule 40.
- **Example 5** shows the effect of reducing the size of the pipe from 4 in schedule 40, to 2 in schedule 40. From the large 93% reduction, it is clear why the smallest diameter pipe suitable for the application should be used.

These and other piping guidelines are summarized in [Section 19.0 on page 77](#). Note that while the emphasis here is on attached piping, these recommendations apply equally to attached electrical conduit and cables.

If several pipes are attached to a vessel, the vertical force exerted on the vessel can be calculated for each individually, as described above, then added together to get the total force F acting vertically on the vessel.

That is:

$$F = F_1 + F_2 + F_3 \dots$$

Where F_1 is the force exerted by pipe 1, F_2 the force exerted by pipe 2, etc.

Accepted practice in the scale industry for ensuring that piping does not adversely affect the required accuracy is to ensure that the following relationship is satisfied:

$$F \leq 0.1 \times [\text{system accuracy (\%)}] \times [\text{live load (lb)}]$$

For example, if a vessel's live load is 50,000 lb and a system accuracy of 0.25% is required, then

$$F \leq 0.1 \times 0.25 \times 50,000$$

$$F \leq 1,250 \text{ lb}$$

I.e., the sum of all vertical pipe forces must be less than or equal to 1,250 lb.

18.2 Example 2

The vessel shown has the following characteristics:

- 40,000 lb live load
- Mounted on 4 each 20,000 lb single-ended beams with full scale deflections of 0.010 in
- Structure deflection of 0.375 in
- Accuracy requirement of 0.5%
- Material is stainless steel throughout

1. Determine allowable F value:

$$F \leq 0.1 \times [\text{system accuracy (\%)}] \times [\text{live load (lb)}]$$

$$F \leq 0.1 \times 0.5 \times 40,000$$

$$\leq 2,000 \text{ lb}$$

The sum of all vertical pipe forces must be less than or equal to 2,000 lb.

2. Determine total deflection. Since the live load represents only $\frac{1}{2}$ of the load cell capacity, the load cell deflection will be:

$$\frac{0.010}{2} = 0.005 \text{ in}$$

Total deflection $\Delta h =$ load cell deflection + structure deflection
 $= 0.005 + 0.375$
 $= 0.380 \text{ in}$

3. Determine F_X for each pipe using the formula:

$$F_X = \frac{0.59(D^4 - d^4) \times (Dh) \times E}{l^3}$$

$$F_1 = \frac{0.59(3.50^4 - 3.07^4) \times 0.380 \times 28,000,000}{72^3}$$

$$= 1,029 \text{ lb}$$

$$F_2 = \frac{0.59(2.375^4 - 2.07^4) \times 0.380 \times 28,000,000}{60^3}$$

$$= 391 \text{ lb}$$

$$F_3 = \frac{0.59(3.50^4 - 3.07^4) \times 0.380 \times 28,000,000}{84^3}$$

$$= 648 \text{ lb}$$

$$F_4 = \frac{0.59(1.315^4 - 1.049^4) \times 0.380 \times 28,000,000}{36^3}$$

$$= 239 \text{ lb}$$

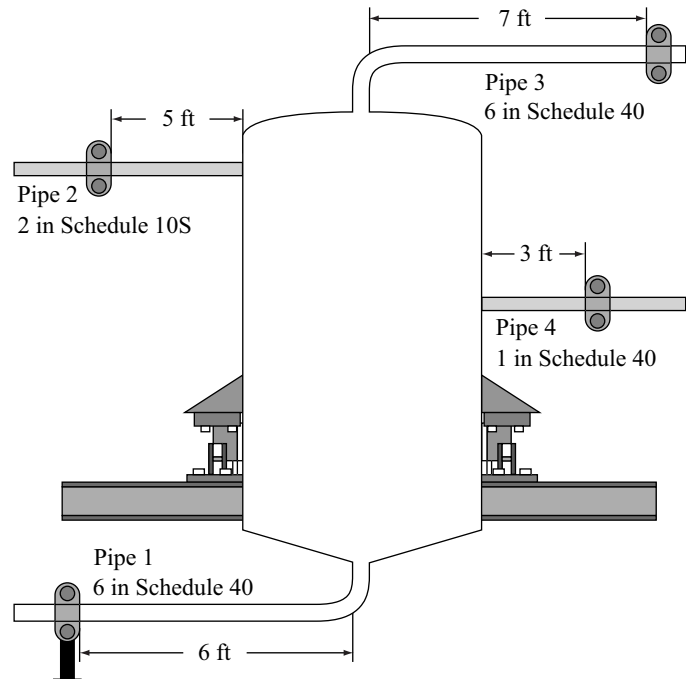

4. Determine F using the formula:

$$\begin{aligned} F &= F_1 + F_2 + F_3 + F_4 \\ &= 1,029 + 391 + 648 + 239 \\ &= 2,307 \text{ lb} \end{aligned}$$

Since F calculated for the vessel is greater than the value determined in Step 1, this is not acceptable. There are several solutions.

- Accept a lower accuracy (perhaps 1%, instead of 0.5%)
- Reduce the deflection of the support structure
- Improve the piping by:
 - using smaller, lighter pipes
 - use flexible hose or bellows
 - increase the distance to the first pipe support points

If we apply the third bullet, improve the piping by increasing the distance to the first pipe support points, then we would focus our attention on the main offender, pipe 1. The problem can be solved simply by increasing the distance to the first support from 72 in to 82 in, yielding an $F_1 = 697$ lb.

Therefore, $F = 697 + 397 + 648 + 239 = 1,975$ lb

This is less than 2,000 lb and the design is now acceptable.

19.0 Piping Guidelines

Incorrect	Piping Guidelines	Correct
	<p>Use the smallest diameter pipe suitable for the application.</p>	
	<p>Use the lightest wall pipe suitable for the application.</p>	
	<p>Do not attach pipes directly to the vessel if possible (vented systems). Allow them to enter through large clearance holes. Flexible boots may be used to seal out dust if necessary.</p>	
	<p>Do not run an attached pipe vertically to its first support point. This will suspend the vessel and destroy accuracy. All pipes should be run horizontally away from the vessel.</p>	
	<p>Increase the distance between the vessel and the first pipe support.</p>	
	<p>Avoid long vertical runs of pipe, particularly when they are restrained from vertical movement. This is because any thermally induced expansion/contraction of the vertical pipe will be translated into detrimental vertical forces on the vessel, directly affecting accuracy.</p>	
	<p>Use flexible hose to make the connection to the vessel. Do not use the flexible hose to compensate for an initial offset in the pipes.</p>	

Table 19-1. Piping Guidelines

Incorrect	Piping Guidelines	Correct
	<p>Use flexible bellows to make the connection to the vessel, if possible. Do not use the bellows to compensate for an initial offset in the pipes. Two bellows may be used in series where large deflections must be accommodated.</p>	
	<p>Placing a right angle bend in the pipe in a horizontal plane greatly reduces the stiffness of the pipe. Pipe supports should be used to strengthen the positioning of the pipe.</p>	
	<p>Avoid tilting of the weigh vessel as a result of non-uniform support stiffness. Small rotations of the vessel can be amplified into large movements at the first support.</p>	
	<p>Do not support pipes on a structure which may deflect independently of the vessel. Support pipes from the vessel's support structure so that the support point moves with the vessel, thus reducing the relative deflection.</p>	
	<p>Do not attach all pipes to the same side of the vessel. Arrange them symmetrically around its diameter, as far as possible.</p>	
	<p>Fill pipes for liquids should enter horizontally so that impingement of in-flight material has minimal effect on the weight reading.</p>	

Table 19-1. Piping Guidelines (Continued)

Incorrect	Piping Guidelines	Correct
	<p>With granular materials, fill the vessel symmetrically. Use a deflector cone to help distribute/level the material.</p>	
	<p>Do not use rubber pads or other devices which will increase the deflection of the vessel under load. Strengthen the support structure to reduce deflection.</p>	
	<p>Do not allow a common discharge pipe to hang directly from the vessels. In the example at left, discharging tank B will temporarily add weight to tank A. For a better installation, support the pipes independently.</p>	
	<p>Flexible electrical cables should not run vertically to a weigh vessel; they should run horizontally or provide a loop as shown.</p>	

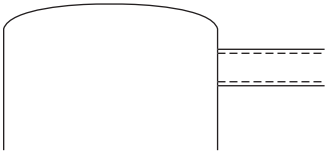
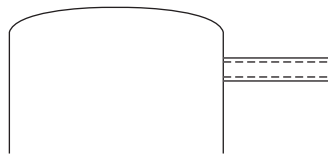
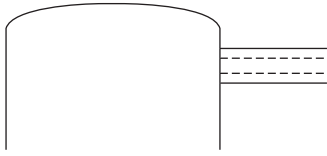
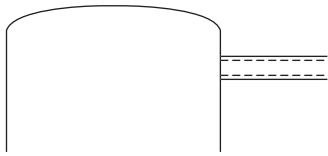
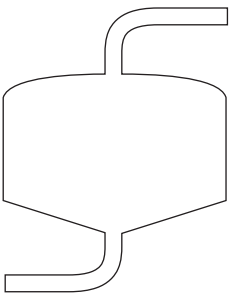
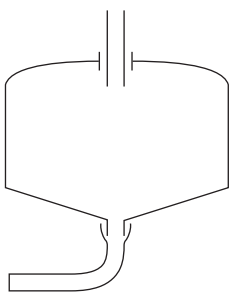
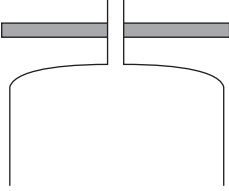
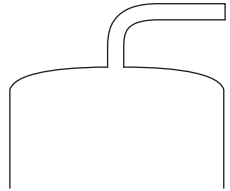
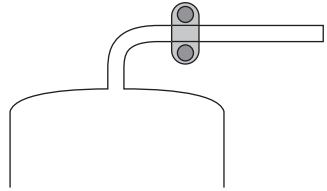
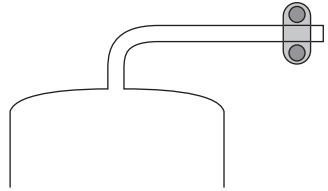
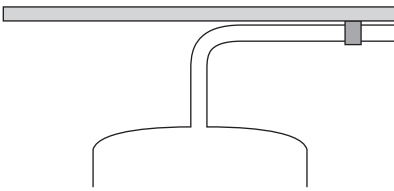
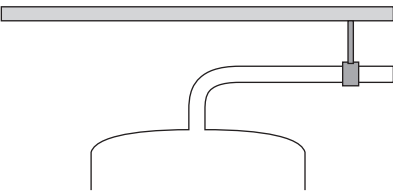
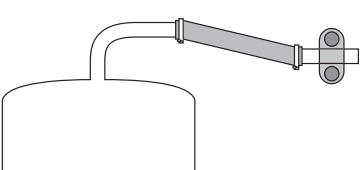
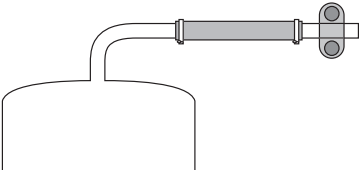
Table 19-1. Piping Guidelines (Continued)

20.0 Vessel Restraint Systems

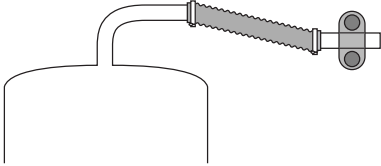
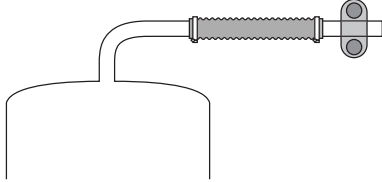
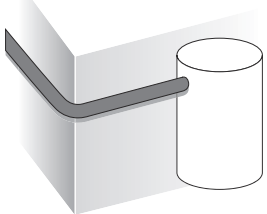
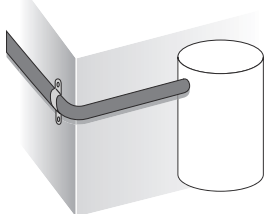
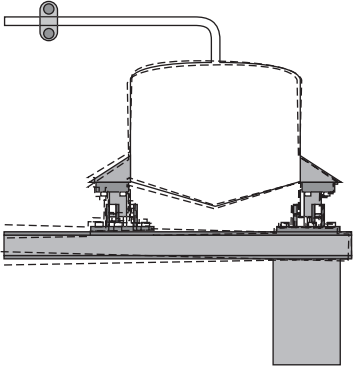
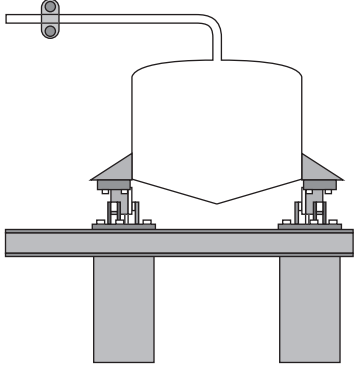
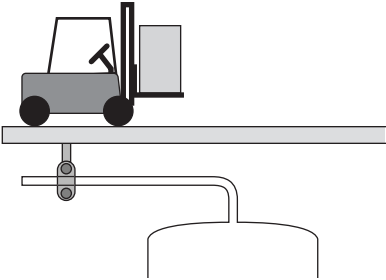
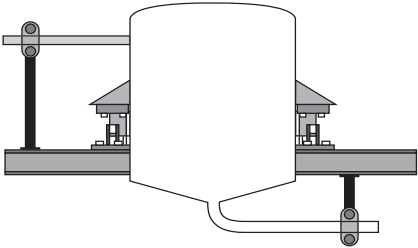
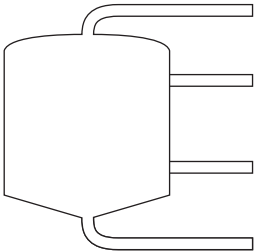
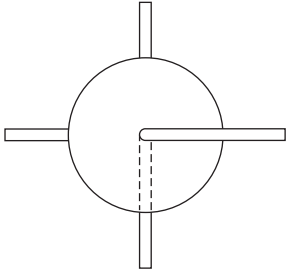
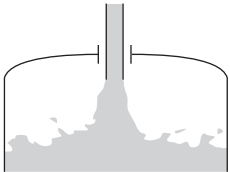
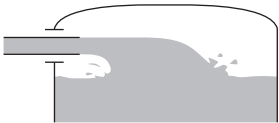
While many of the mounting arrangements offered by Rice Lake Weighing Systems are self checking, there are situations where additional vessel restraints may be required to steady a vessel subjected to constant vibration, or to restrain a vessel from toppling or falling in the event of some unforeseen circumstance. Two main types of restraint systems are stay rods and check rods.

20.1 Stay Rods

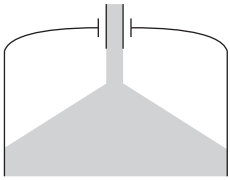
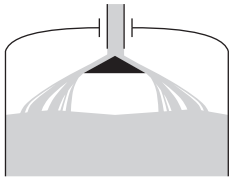
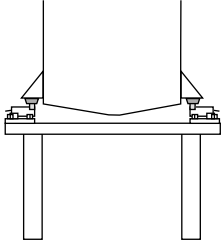
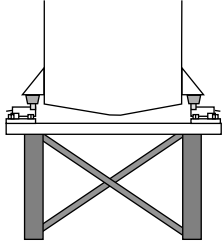
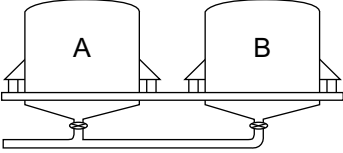
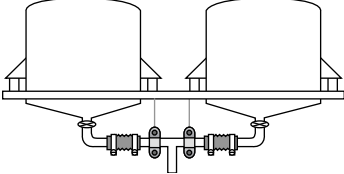
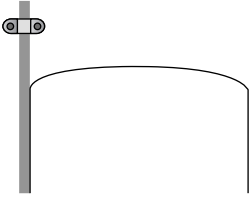
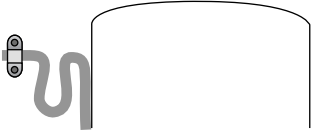
Stay rods are used to rigidly restrain a vessel in the horizontal direction. These rods are installed horizontally in tension between a bracket on the vessel and a bracket attached to the vessel's support structure or foundation. Because of the negligible deflection of load cells under load, the stay rods will have little effect on the accuracy of the system when installed properly. It is necessary to install a number of rods to restrict a vessel fully in a horizontal plane; see [Figure 20-1](#). On a circular vessel, the rods should always be tangential. This prevents the vessel from shifting in any direction, but leaves it free for thermal expansion/contraction.

[Figure 20-2](#) illustrates stay rods attached to a suspended vessel. The rods must be horizontal so that they do not affect the weighing accuracy. Fastening nuts are tightened so the rod is snug; do not over-tighten. This placement of the nuts ensures the rods operate in tension and are never subjected to a compressive or buckling load.

Stay rods are used to:

- Improve system stability and accuracy by limiting vessel oscillation or vibration.
- Protect piping from fatigue due to constant vessel movement.
- Ensure the stability of tall slender vessels or vessels with heavy eccentrically mounted equipment.
- Ensure the stability of vessels against wind, seismic forces or threat from vehicular traffic.
- Hold a vessel in place when mounted on canister cells. These cells have very little tolerance of side forces and must be loaded in the vertical direction only.

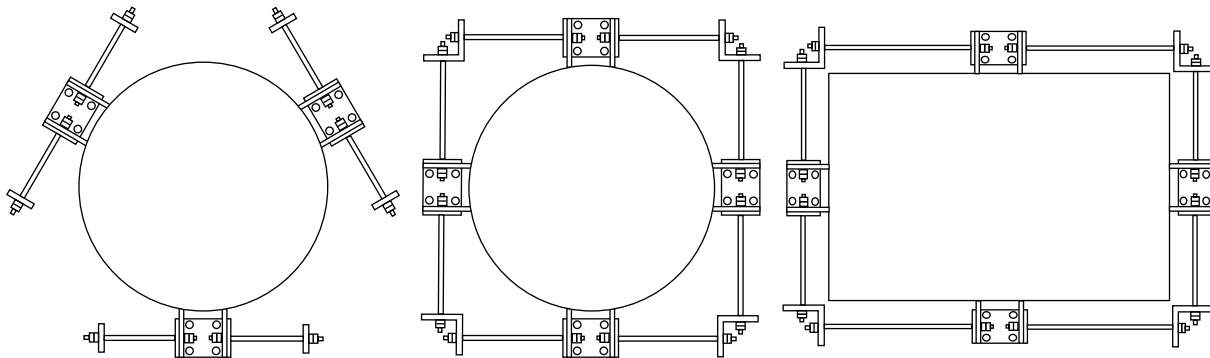

Figure 20-1. Stay Rod Applications

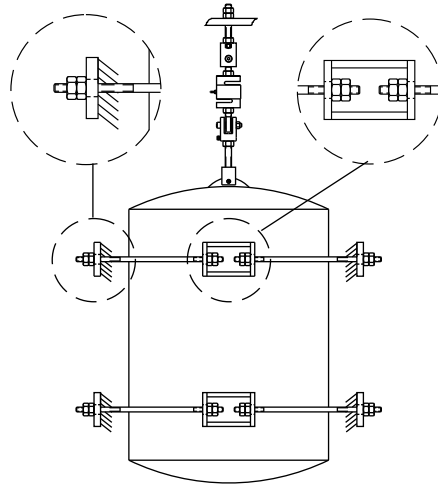

Figure 20-2. Stay Rod Application



NOTE: When using stay rods to provide vessel stability, they are most effective when attached at or above the center of gravity of the filled vessel. Stay rods should be made as long as practical, as this will be beneficial in reducing forces in the vertical direction. It should be emphasized that the rods must be horizontal; for this reason one of the attachment points should be adjustable in a vertical direction.

20.2 Safety Check Rods

Safety check rods are similar to stay rods in that they may be applied to a vessel in similar fashion as stay rods. However, they are fitted loosely to the vessel and may also be applied in a vertical direction.

Safety check rods are left loose so that under normal operation they do not apply any axial forces to the weigh vessel. They are not an active part of the weigh system. The safety check rods shown do add to the tare weight of the vessel, but this is constant and does not affect the weighing accuracy. Safety check rods are, as the name implies, a safety feature intended to restrain the vessel if and when it is subjected to large external or internal forces or if there is a mechanical failure in the vessel's normal support mechanism.

Horizontal safety check rods should be used to:

- Ensure the stability of tall slender vessels or vessels with heavy eccentrically mounted equipment.
- Ensure the stability of vessels against wind or seismic forces or threat from vehicular traffic.

As shown in [Figure 20-3 on page 82](#) (a), to be most effective, safety check rods must be fitted at or above the filled vessel's center of gravity. Note that stay rods will perform all these functions and more; however, safety check rods are less critical to system operation and therefore do not require the same attention to detail for successful installation.

Vertical safety check rods should be used:

- On all vessels mounted in tension where failure of the normal suspension means would allow the vessel to fall and cause injury or damage, see [Figure 20-3 \(b\)](#).
- In place of horizontal check rods when it is not practical to use these to ensure the stability of tall slender vessels or those subjected to wind or seismic forces, see [Figure 20-3 \(c\)](#).

Vertical safety rods must be installed in an oversized hole in the lower bracket so that they do not interfere in any way with the vertical movement of the vessel.

For more information, see [Section 15.0 on page 55](#).

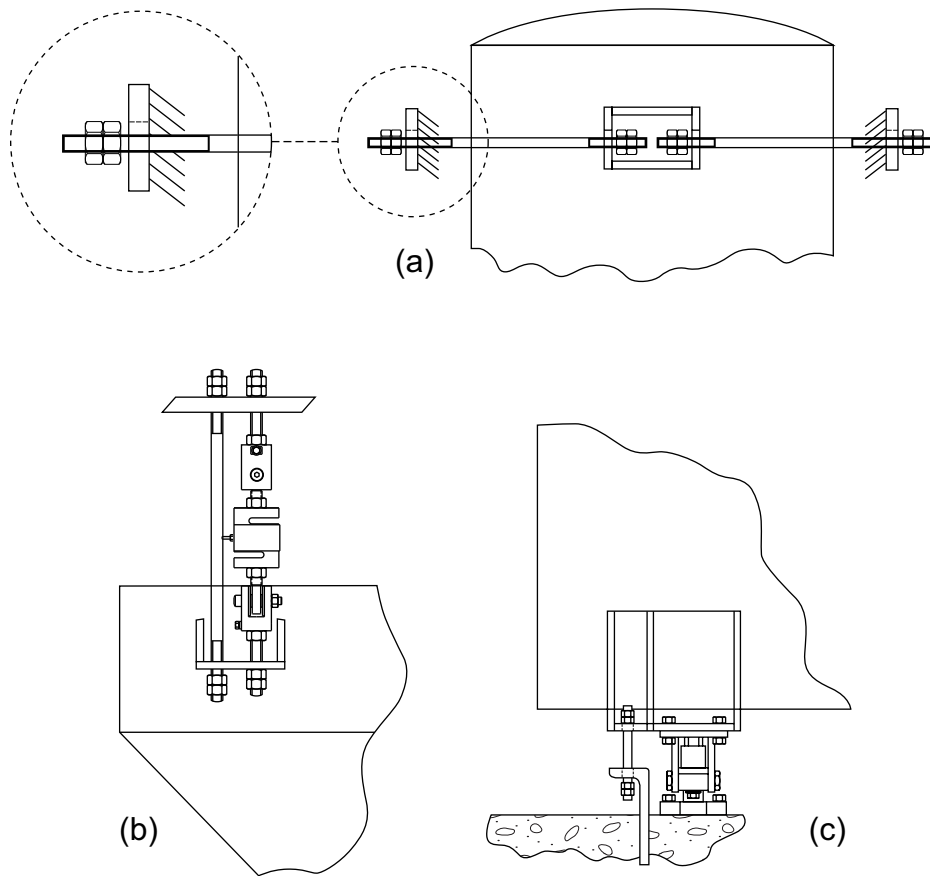

Figure 20-3. Safety Check Rods

Installation and Service Tips

21.0	Determining Microvolts per Graduation	84
22.0	Load Cell Mounting Hardware Safety Guidelines	85
22.1	Safety Backup	85
22.2	Estimating Gross Load	85
22.3	Safe Load	85
22.4	Load Distribution	85
22.5	Threaded Connections	85
22.6	Jam Nuts	85
22.7	Wire Rope Assemblies	85
22.8	Attachment Points of a Load Cell Hardware Assembly	85
22.9	Swaying in a Suspended Vessel Scale	85
22.10	Hopper Scales: Guarding Against Contamination	85
22.11	Selecting Steel Rod or Any Other Weight-Bearing Components	86
23.0	Load Cell Trimming	87
23.1	Load Cell Trimming	87
23.2	Excitation Trim	87
23.2.1	Excitation Trimming Procedure	88
23.3	Signal Trim	89
23.4	What is mV/V/Ohm Calibration?	89
23.4.1	Traditional Method	89
23.4.2	Paramounts	90
24.0	Load Cell Troubleshooting	91
24.1	Physical Inspection	91
24.2	Zero Balance	91
24.3	Bridge Resistance	92
24.4	Resistance to Ground	93
25.0	Calibration Guidelines for Vessel Weighing Systems	94
25.1	Calibration Using Certified Test Weights	94
25.2	Calibration Using Weighed Material	94
25.3	Calibration Using Material Substitution Method	94
25.4	Calibration Using A Load Cell Simulator	95

21.0 Determining Microvolts per Graduation

Whether sizing load cells for a mechanical conversion, replacing truck scale cells or designing a weighing vessel, it's tempting to pick a grossly oversized load cell for "overload insurance." This practice can create a problem that can cost many hours in troubleshooting and redesign. If the capacity is oversized too much, the signal output may be cut to a point where the system will not operate as planned. Determining the application's required microvolts per graduation ($\mu\text{V}/\text{grad}$) will allow for proper sizing of a load cell, ensuring adequate signal and overload protection.

The signal sensitivity of electronic digital weight indicators is specified as a minimum microvolt per graduation value. A microvolt (μV) is one millionth of a volt. The μV per graduation value is the amount of scale output signal change required to change the meter display one graduation. If the scale output signal is below this value, the meter will not perform properly.

The following process will help to determine the μV per graduation rating of the weighing system:

1. Determine full scale output of the load cell (output signal at 100% of capacity).

For example: A cell rated at 3.0 mV/V, when supplied with 10 V of excitation from a digital weight indicator, will provide 30 mV of full scale output.

$$3.0 \text{ mV/V} \times 10 \text{ V} = 30 \text{ mV.}$$

2. Determine how much of the output will be caused by the live load in the application. If the cell has a capacity of 500 kg and the live load placed on it is 300 kg, then 60% of the total capacity of the cell is live load.

$$\frac{250}{500} = 0.50 \text{ or } 50\%$$

3. Determine how much signal represents the live load by multiplying full scale load cell output by the actual amount of live load at full scale.

$$30 \text{ mV} \times 0.5 = 15 \text{ mV}$$

4. Actual $\mu\text{V}/\text{graduation}$ rating is determined by dividing the live load signal by the number of graduations the electronic digital weight indicator is programmed to read. If the indicator is set for 5,000 graduations then:

$$\frac{15 \text{ mV}}{5,000 \text{ grads}} = 3.0 \mu\text{V}/\text{graduation}$$

If the $\mu\text{V}/\text{graduation}$ rating was less than the minimum sensitivity rating on the indicator, the installation will not work. The live load signal needs to be increased.

This can be done by increasing the excitation level. In #1, if 15 V of excitation were used instead of 10 V, then $15 \times 3.0 \text{ mV/V} = 45 \text{ mV}$. By completing the rest of the formula, the $\mu\text{V}/\text{graduation}$ would be $4.5 \mu\text{V}$.

Use a cell with higher full scale output. This works if the original cell was less than 3.0 mV/V; generally few standard cells are available with more than 3.0 mV/V output.

Counterbalance the dead load off the load cell. This may allow the use of a smaller capacity load cell, thus raising the μV rating, as a greater portion of the total output will be live load signal.



CAUTION: If a signal problem is experienced, using an oversized load cell will worsen the $\mu\text{V}/\text{graduation}$ rating. This is because even less of the full scale output would be live load signal. As an example, if a 1,000 kg cell were in the given example instead of a 500 kg cell, only 25% of the capacity would be used.

This would give a $\mu\text{V}/\text{graduation}$ of:

$$\frac{30 \text{ mV} \times 25\%}{5,000 \text{ grads}} = 1.5 \mu\text{V}/\text{graduation}$$



NOTE: A microVolt per grad calculator can be found under Rice Lake scale tools at <https://scaletools.ricelake.com/#/uv-graduation>.

22.0 Load Cell Mounting Hardware Safety Guidelines

Install only load cell mounting hardware and assemblies that have been specifically designed for use in tank, hopper or hanging scale applications. Often, the use of an inferior-grade product results in component failure, which risks equipment damage and personal injury. These simple suggestions are provided to help minimize the exposure to vessel-scale installation hazards.

22.1 Safety Backup

If failure of one or more load cell hardware assemblies could cause injury or damage, a safety backup (safety chains, safety rods, etc.) must be used. The assemblies must be inspected routinely for damage, excessive wear or corrosion, and replaced if necessary.

22.2 Estimating Gross Load

To select the correct load cell or load cell hardware for a given application, it is necessary to know the total weight on the scale, including the net weight of product, the tare weight of the vessel and the weight of the platform, tank or hopper, as appropriate.

22.3 Safe Load

Do not exceed the safe-load figures listed in this catalog for any load cell hardware. Where shock loads are present, it may be necessary to derate these safe-load figures depending on the severity of the shock load.

22.4 Load Distribution

In multiple load cell applications, make certain that the weight is evenly distributed between all cells.

22.5 Threaded Connections

Be sure that all threads of a threaded connection are in engagement. For example, an eye bolt that is screwed into an S-type load cell should protrude slightly on the opposite side.

22.6 Jam Nuts

Lock any threaded connections with a jam nut to prevent inadvertent disassembly. If a load is suspended from a single load cell, make sure the load cannot rotate, as this may loosen the jam nut.

22.7 Wire Rope Assemblies

With wire rope assemblies, do not twist the rope during assembly or disassembly. For example, do not remove a frozen nut from one end of a rope assembly by holding the opposite end. Do not use wire ropes to suspend a load without use of safety chains or safety rods.

22.8 Attachment Points of a Load Cell Hardware Assembly

Ensure that the attachment points of a load cell hardware assembly are aligned properly and that the assembly is essentially vertical.

22.9 Swaying in a Suspended Vessel Scale

If there is excessive swaying in a suspended vessel scale, apply horizontal checking to reduce movement.

22.10 Hopper Scales: Guarding Against Contamination

With hopper scales, guard against contamination of the product being weighed as a result of the failure of the load cell or hardware assembly. For example, do not locate a wire rope assembly over a hopper scale where broken strands of wire could fall into the weighing vessel, contaminating the product being weighed.

22.11 Selecting Steel Rod or Any Other Weight-Bearing Components

Select steel rod or any other weight-bearing components so that their minimum tensile strength is at least four times the total weight carried by that component. Note that threaded rod is generally made from a low tensile strength mild steel which should be checked for tensile strength before use in any suspended vessel scale.



NOTE: Based on dry assembly. Variables such as lubrication, plating, etc. may reduce the values listed above as much as 20% and must be taken into consideration. General formula for calculating torque is as follows: $\text{Torque in Nm} = 0.2 \times \text{Nominal Diameter of Screw} \times \text{Load in lb}$, where load = 80% of yield strength, expressed in lb, not pounds per square inch. The tension induced in a cap screw may be checked by measuring overall length before torquing.

Cap Screw Diameter	UNC	UNF
1/4"	10.8	13.5
5/16"	23.0	25.7
3/8"	40.6	47.4
7/16"	67.7	88.1
1/2"	101.6	122.0
9/16"	149.1	162.7
5/8"	203.3	244.0
3/4"	352.5	406.7
7/8"	583.0	637.2
1"	867.7	962.6
1-1/8"	1084.7	1193.1
1-1/4"	1518.5	1681.2
1-3/8"	1979.5	2278.0

Table 22-1. Steel Rod Tensile Strength - Recommended Torque for SAE Grade 5 (Nm)

23.0 Load Cell Trimming

It may be necessary to trim the load cell outputs as a first step before starting the calibration process. Trimming is performed at the junction box to equalize the weight reading from all cells in a system. This ensures that the scale weighs correctly regardless of where the load is applied to the scale.

Trimming is necessary if:

1. It is a Legal for Trade weighing application.
- *2. The location of the center of gravity of the contents is not fixed, e.g., powder material which may accumulate on one side.
- *3. A high-accuracy weighing system is required.

Trimming is not necessary if:

4. Matched output load cells are used (as in the Paramounts).
5. Weighing self-leveling materials (liquids).

*Assume that the vessel's center of gravity (see 2 and 3 above) rises along the same vertical line as the vessel is filled. Each load cell is always subjected to the same percentage of the weight.

Trimming involves placing the same weight over each load cell in turn, and adjusting the corresponding trim pot in the junction box until the indicator reads the same for all cells. To further illustrate load cell trimming, please review the following examples of signal trim and excitation trimming procedures.

23.1 Load Cell Trimming

Many weighing systems use multiple load cells and therefore require a summing junction box to tie or "sum" the load cell signals together, allowing a digital weight indicator to read a single "system" signal. The summing process actually wires multiple load cells so that all their signal lines and excitation lines are in parallel, providing instantaneous electronic summing of the signals.

Load cell summing is necessary because:

- Weight distribution in multiple load cell systems is not equal at each load cell. The vessel loading process, presence of agitators, the characteristics of the material and many other factors affect weight distribution on the load cells.
- It is virtually impossible to make each load cell exactly alike. Load cell manufacturing process tolerances allow for some variance in individual cell specifications. This variance, if unchecked, would not allow for the kinds of accuracy required in modern process applications.

There are two summing methods: excitation trim and signal trim.

23.2 Excitation Trim

This is the oldest method of trimming the output from a strain gauge load cell. Excitation trimming adds series resistance to the excitation circuit of the load cell, thereby reducing the excitation voltage at the cell. The load cell with the lowest mV/V output receives the full excitation voltage. All other load cells in the system with a higher mV/V output receive proportionally smaller excitation voltages. This results in matched full load outputs for all load cells in the system.

[Figure 23-1 on page 88](#) is a functional diagram of an excitation trim J-box. Note that a variable resistor or potentiometer (pot), is inserted in the + excitation lead of each load cell. If the pot is opened so that resistance is zero, the full excitation voltage is applied to the load cell. As resistance is increased, excitation voltage decreases.

23.2.1 Excitation Trimming Procedure

The simplest method of trimming with excitation is to set up the system, turn all trim pots to the “open” or full excitation setting, and test each corner of the system with a calibrated test weight or any dead weight. Once the lowest output corner is located, the other cells are trimmed to match by physically loading with the same weights and adjusting the pots. This procedure can be practical if used in field replacement of load cells in light-capacity floor scales. It is not typically used in heavy-capacity scales where application of test weights to corners in such a manner is not practical.

Another method is pre-trimming. Here, the load cells are trimmed by mathematically calculating the excitation voltage for the load cell, then measuring the excitation voltage with a voltmeter, while adjusting the pot to the required voltage. The following five steps walk through this procedure.

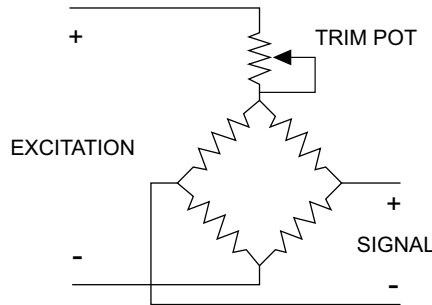

Figure 23-1. Excitation Trimming Load Cells

1. Determine how much excitation voltage the electronic digital weight indicator is supplying to the load cells. This is found by measuring, with a voltmeter, the actual excitation voltage present at the reference cell's excitation leads. For this example, use 10 volts DC.



NOTE: The reference cell is the cell with the lowest mV/V rating, as shown on its calibration certificate.

2. Determine the exact mV/V rating of each load cell and locate the cell with the lowest rating. The exact mV/V rating is found on the calibration certificate supplied with the load cell or on the label itself. Just because a cell is rated at 3 mV/V, don't assume it's exactly 3 mV/V.

#1 = 2.997 mV/V	#3 = 2.999 mV/V
#2 = 3.003 mV/V	#4 = 3.002 mV/V

 Cell number 1 has the lowest rating at 2.997 mV/V.
3. Calculate the trimming factor by multiplying the lowest mV/V by the excitation voltage.

$$2.997 \text{ mV/V} \times 10\text{V} = 29.970 \text{ mV}$$
4. Calculate the adjusted excitation voltage for the remaining load cells and adjust each respective trim pot to the appropriate voltage level.

#1 = leave alone, lowest mV/V
#2 = $29.97 \text{ mV} \div 3.003 \text{ mV/V} = 9.980 \text{ volts}$
#3 = $29.97 \text{ mV} \div 2.999 \text{ mV/V} = 9.993 \text{ volts}$
#4 = $29.97 \text{ mV} \div 3.002 \text{ mV/V} = 9.983 \text{ volts}$

 The scale is now trimmed.
5. Verify the results with certified test weights or a known amount of material.

23.3 Signal Trim

This form of trimming first appeared as an alternative to excitation trimming for indicators with gated power supplies. Because of the compatibility that signal trimming has with virtually all indicators and its relative immunity to temperature and vibration problems, signal trimming is gaining popularity for all installations. It involves adding a relatively high parallel resistance between the signal leads of each load cell as shown in Figure 23-2. The added parallel resistance creates a “leakage path” that shunts some of the available load cell signal away from the indicator. The larger this parallel resistance, the more signal available to the indicator from the load cell. Conversely, the smaller this parallel resistance, the less signal available to the indicator from the load cell.

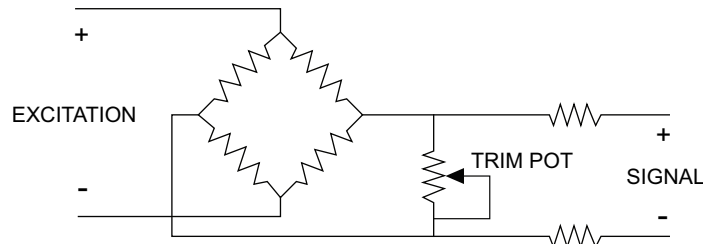

Figure 23-2. Signal Trimming Procedure

23.4 What is mV/V/Ohm Calibration?

The Paramounts along with several Rice Lake brand load cells utilizes a unique system of mV/V/ohm calibration to ensure that all their load cell outputs match precisely. While there are other manufacturers who offer a similar calibration concept, there are important technical differences provided with Flintec products.

23.4.1 Traditional Method

This approach adjusts the short circuit current (mV/ V/ohm) of each load cell to a standard value, within a close tolerance. This ensures that multiple load cell systems will be "corner adjusted" without further trimming, providing there are no mechanical load introduction asymmetries. It also ensures that the system corner adjustment is preserved, even when a load cell is subsequently replaced. It does not, however, preserve the system calibration.

Let's look at this using a simple two-load cell example. Extension to the "n" load cell case is straightforward.

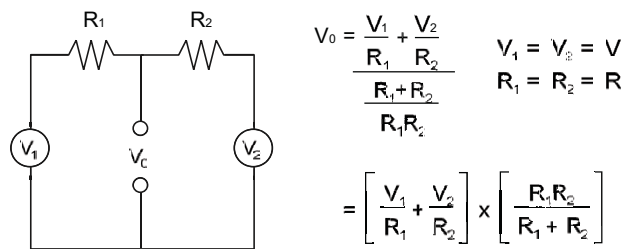

Figure 23-3. Two-Load Cell Example

Where V_1 and V_2 are voltage sources, R_1 and R_2 are resistances. It is easier to understand the concepts by using the Norton equivalent circuit. Here, we have two current sources driving currents through the parallel combination of the load cell source impedances. The currents are the short circuit currents (I) of the respective load cell (mV/V/ohm) and they are set equal to some standard value. Note that the mV/V output is the same as in the arrangement above.

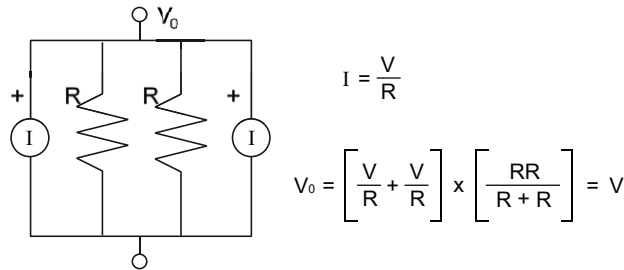

Figure 23-4. Norton Equivalent Circuit

In either case, the system is "cornered." That is, the system output is the same whether the load cells are equally loaded or all the load is on one or the other load cell. Now let's replace the right hand load cell with a unit which has a source resistance that is 2% higher than the load cell it replaced. Since it must have the same short circuit current (mV/V/ohm), its open circuit output voltage will be set 2%.

$$I = \frac{1.02 V}{1.02 R} = \frac{V}{R} \quad V_0 = \left[\frac{V}{R} + \frac{V}{R} \right] \times \left[\frac{1.02 RR}{2.02 R} \right] = 1.01 V$$

Now we have the two current generators driving their currents through the parallel combination of their source impedances as before. The system is still "cornered" but the system output is 1% higher, because the parallel combination of the two source impedances is now 1% higher, or the open circuit output voltage of the replacement load cell is 2% higher. So, the system must be recalibrated. This can be a difficult task, especially with high-capacity vessel scales. Unfortunately, the conventional approach does nothing to avoid the need for recalibration after load cell replacement.

23.4.2 Paramounts

Given the same set of circumstances regarding the replacement load cell (source impedance 2% higher), the short circuit current is set to the standard value, as before, but the open circuit voltage is adjusted to a standard value by loading the output terminals with resistance that drops the output voltage of the replacement load cell to the standard value. In this example, a resistance of $51R$ is placed across the output terminals of the replacement load cell and that additional resistor is shown added to the paralleled source resistances in the figure below.

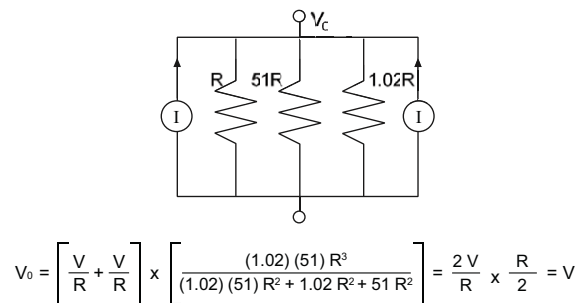

Figure 23-5. Norton Equivalent Circuit with Additional Resistor

Now the standardized current sources are driving their short circuit currents through the paralleled source resistances; the third resistance, the paralleled combination of the three resistances, is now equaling the original value of $R/2$. Hence the output voltage with the replacement load cell in place is the same as it was before the replacement. Not only is the system still "cornered," but the system calibration has been maintained. There is no need for system recalibration after load cell replacement. All Flintec load cells are factory-calibrated in the above manner.

24.0 Load Cell Troubleshooting

Here are some easy-to-follow steps to help troubleshoot potential load cell problems. Before beginning, a high-quality digital multimeter will be needed. The tests are: physical inspection, zero balance, bridge resistance and resistance to ground.

24.1 Physical Inspection

How does it look? If it is covered with rust, corroded or badly oxidized, chances are the corrosion has worked its way into the strain gauge area as well. If the general and physical condition appear good, then look at specifics: sealing areas, the element itself and the cable.

In most load cells, areas of the load cell are sealed to protect the contents from contamination by water and chemicals. To see if any seals have been degraded, get close to the cell and look at the strain gauge seals (Figure 24-1 points A). Is rust concentrated on a part of the cover weld? If there is no cover, look to see if there are any tiny holes in the potting. These are indications that there has been contamination to the gauge area. Check the load cell cable entrance (Figure 24-1 point B) for signs of contamination.

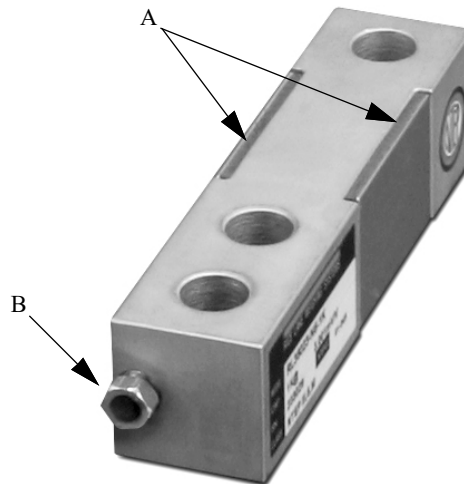

Figure 24-1. Load Cell

Other items to look for: metal distortion or cracks, metal rippling, cracks in the weld or abrasions in the metal. It may be necessary to remove the load cell and check it for physical distortion against a straight edge.

No inspection would be complete without thoroughly inspecting the cable. Cable should be free of cuts, crimps and abrasions. If the cable is cut and in a wet environment, water or chemicals can “wick” up the cable into the strain gauge area, causing load cell failure.

If your physical inspection fails to uncover any identifiable damage, a more detailed evaluation is required.

24.2 Zero Balance

This test is effective in determining if the load cell has been subjected to physical distortion, possibly caused by overload, shock load or metal fatigue. Before beginning the test, the load cell must be in a “no load” condition. That is, the cell should be removed from the scale or the dead load must be counterbalanced.

Now that the cell is not under any load, disconnect the signal leads and measure the voltage across the negative signal and positive signal. The color code for determining negative- and positive-signal leads is provided on the calibration certification with each load cell. The output should be within the manufacturer’s specifications for zero balance, usually $\pm 1\%$ of full scale output. During the test, the excitation leads should remain connected with the excitation voltage supplied by the digital weight indicator. Be certain to use exactly the same indicator that is used in the cell’s daily operation to get a reading accurate to the application.

The usual value for a 1% shift in zero balance is 0.3 mV, assuming 10 volts excitation on a 3 mV/V output load cell. To determine the application's zero shift, multiply the excitation volts supplied by the indicator by the mV/V rating of the load cell. When performing a field test, remember that load cells can shift up to 10% of full scale and still function correctly. If the test cell displays a shift under 10%, there may be another problem with the suspect cell, and further testing is required. If the test cell displays a shift greater than 10%, it has probably been physically distorted and should be replaced.

24.3 Bridge Resistance

Before testing bridge resistance, disconnect all of the load cell wires from the digital weight indicator. Find the positive and negative excitation leads and measure across them with a multimeter to find the input resistance. Don't be alarmed if the reading exceeds the rated output for the load cell. It is not uncommon for readings as high as 375 Ω for a 350 Ω load cell. The difference is caused by compensating resistors built into the input lines to balance out differences caused by temperature or manufacturing imperfections. However, if the multimeter shows an input resistance greater than 110% of the stated output value (385 Ω for a 350 Ω cell or 770 Ω for a 700 Ω cell), the cell may have been damaged and should be inspected further. These are general guidelines. Some load cells will vary; refer back to the load cell's calibration certificate for the actual input resistance allowing for a $\pm 10\%$ variance.

If the excitation resistance check is within specs, test the output resistance across the positive and negative signal leads.

This is a more delicate reading, and should be 350 $\Omega \pm 1\%$ (350 Ω cell). Readings outside the 1% tolerance usually indicate a damaged cell.

Now comes the tricky part. Even if the overall output resistance test was within normal specifications, the load cell could still be damaged. Often when a load cell is damaged by overload or shock load, opposite pairs of resistors will be deformed by the stress—equally, but in opposite directions. The only way to determine this is to test each individual leg of the bridge. The Wheatstone Bridge diagram, in Figure 24-2, illustrates a load cell resistance bridge and shows the test procedure and results of a sample cell damaged in such a manner. We'll call the legs that are in tension under load T_1 and T_2 , and the legs under compression C_1 and C_2 .

With the multimeter, we tested each leg and got the following readings:

- $T_1(-\text{Sig}, +\text{Exc}) = 282 \Omega$
- $C_1(-\text{Sig}, -\text{Exc}) = 278 \Omega$
- $T_2(+\text{Sig}, -\text{Exc}) = 282 \Omega$
- $C_2(+\text{Sig}, +\text{Exc}) = 278 \Omega$

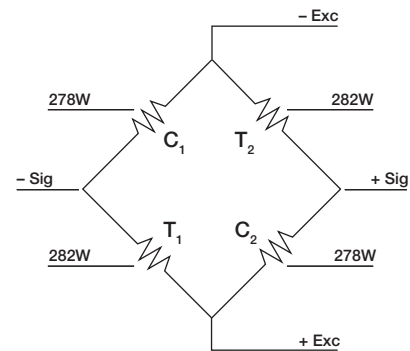

Figure 24-2. Wheatstone Bridge



NOTE: When testing leg resistance, a reading of 0 Ω or ∞ means a broken wire or loose connection within the cell.

In a good load cell in a “no load” condition, all legs need not have exactly equal resistance, but the following relationships must hold true:

1. $C_1 = T_2$
2. $T_1 = C_2$
3. $(C_1 + T_1) = (T_2 + C_2)$

In this damaged load cell, both tension legs read 4 Ω higher than their corresponding compression legs. The equal damage mimics a balanced bridge in the output resistance test (3 above), but the individual leg tests (1, 2 above) show that the cell must be replaced.

There are a small percentage of load cells that are specifically designed with more compensation resistance on either the positive or negative input legs. When testing the individual legs of the bridge, this will give the initial appearance of a bad load cell because of the wide variance of resistance readings. However, the additional resistance will be on just the +Ex legs or the -Ex legs, not both.

Example: $T_1=250.3$ ohms, $C_1=381.1$ ohms, $T_2=381.6$ ohms, $C_2=251.3$ ohms

This type of load cell would be a bridge resistance check for a load cell within tolerance.



NOTE: On multiple-cell applications for matched millivolt output, excitation resistance values may be higher than 110%.

24.4 Resistance to Ground

If the load cell has passed all tests so far but is still not performing to specifications, check for electrical leakage or shorts. Leakage is nearly always caused by water contamination within the load cell or cable, or by a damaged or cut cable. Electrical shorting caused by water is usually first detected in an indicator readout that is always unstable, as if the scale were constantly “in motion.” The wrong type of cell in the wrong application is the leading cause of water contamination. Almost always, these leaking cells are “environmentally-protected” models designed for normal non-washdown, not the “hermetically sealed” models that stand up to washdown and other tough applications.

Another cause is loose or broken solder connections. Loose or broken solder connections give an unstable readout only when the cell is bumped or moves enough so the loose wire contacts the load cell body. When the loaded scale is at rest, the reading is stable.

To really nail down electrical leakage problems, test resistance to ground with a low-voltage megohm-meter. Use caution; a high-voltage meter that puts more than 50VDC into the cell may damage the strain gauges. If the shield is tied to the case, twist all four leads together and test between them and the load cell metal body. If the shield is not tied to the case, twist all four leads and the shield wire together and test between them and the body. If the result is not over 5000 M Ω , current is leaking to the body somewhere.

If the cell fails this test, remove the shield wire and test with only the four live leads to the metal body. If this tests correctly (over 5000 M Ω), it can be reasonably certain the current is not leaking through a break in the cable insulation or inside the gauge cavity.

Minor water infiltration problems can sometimes be solved outside the factory. If it is apparent that water contamination has occurred and is certain that the cable entrance seal is the entry point, try this remedy: remove the cell to a warm, dry location for a few days, allowing the strain gauge potting to dry. Before putting the cell back into service, seal with pliable silicone around the cable entry point in the load cell body. This prevents the reentry of water vapor into the cell.

25.0 Calibration Guidelines for Vessel Weighing Systems

There are various methods available to calibrate a system. This section outlines some of the more common. However, the following recommendations apply regardless of the method adopted.

- If the scale is to be used in Legal for Trade weighing, check with the state or local Weights and Measures authority for specific requirements in your area.
- The weight indicator should be switched on for 20 to 30 minutes (or as recommended by the manufacturer) before beginning calibration.
- The weighing system should be exercised several times by the application and removal of weight before beginning calibration. This ensures that everything is seated properly in place.
- While exercising the weighing system, check the return to zero each time the scale is unloaded. Be certain to turn off any Auto Zero function the indicator may have. If return to zero is poor, check for mechanical binding before proceeding.
- For best accuracy, use a weight of 80 to 100% of scale capacity for calibration.

25.1 Calibration Using Certified Test Weights

This method will yield the most accurate results, however, it can be difficult to place test weights in or on the vessel and attain accurate readings. These difficulties have been overcome in some installations by providing a means of hanging test weights from the vessel by chains.

1. Remove all weights from the vessel.
2. Zero the indicator (follow the manufacturer's instructions).
3. Place test weights on the vessel equal to 80 to 100% of scale capacity, evenly distributed.
4. Adjust the indicator until it reads the weight applied to the vessel.
5. Remove the test weights, check the return to zero, adjust if necessary.
6. Reapply the weights once more to verify the calibration.

25.2 Calibration Using Weighed Material

This method uses a known weight of material (often water or sand) as a test weight. This material is often loaded on a truck of known tare weight, weighed on a truck scale and transported to the job site. It is important that material is not lost or altered in transit. Use the same calibration procedure as described under Calibration Using Certified Test Weights where the weighed material is used in place of the certified test weights.

25.3 Calibration Using Material Substitution Method

This method is used to accurately calibrate high-capacity scales when a limited amount of certified test weights are available. It allows for the substitution of the known weight of material in a stepped fashion.

1. Remove all weight from the vessel.
2. Zero the digital weight indicator.
3. Place test weights on the vessel equal to at least 5% of scale capacity.
4. Adjust the indicator until it reads the weight applied to the vessel.
5. Remove test weights and replace with material until indicator accurately displays the weight of the certified test weights.
6. Again place the test weights on the vessel with the material. Record the indicator reading of the total weight of material and test weights.
7. Remove the test weights and replace with additional material until the indicator reads the total recorded weight.
8. Again place the test weights on the loaded vessel. Record the indicator reading.
9. Repeat this process until the applied weight (certified test weights and added material) is between 80 to 100% of total scale capacity.
10. The weight now applied to the scale is the weight of certified weights plus material multiple. (For example, if the certified weights total 5,000 kg and 8 material substitutions were made, then the total weight on the scale is now = $5,000 + (8 \times 5,000) = 45,000$ kg).

25.4 Calibration Using A Load Cell Simulator

This is the simplest and fastest method of scale calibration, particularly on heavy-capacity scales. However, it is less accurate than the other methods described. A major disadvantage is that it doesn't test the scale mechanically or take into account the influence of friction, piping, support deflection, etc. This method is sometimes sufficient for process weighing applications that need not meet Legal for Trade requirements.

The following example is based on the premise that a power supply of exactly 10 VDC is used. Measure the power supply for the exact excitation voltage to obtain specific results.

To calibrate with a simulator:

1. Disconnect the cable from the junction box at the indicator.
2. Connect a load cell simulator to the indicator. The simulator should have a vernier for fine adjustments.
3. Set the simulator to 0.0 mV/V and zero the indicator.
4. Set the simulator's output (in mV/V) to simulate the output of the load cells at full scale capacity (ignoring dead load for now). To find the simulated full scale output, use the following formula:

$$\frac{\text{Total Load Cell mV/V Output}}{\text{Total Load Cell Capacity}} = \frac{\text{Simulator mV/V Setting}}{\text{Displayed Weight}}$$

For example:

If four 5.000 kg, 3 mV/V load cells are used for a 10.000 kg capacity scale, the simulator setting expected when 10.000 kg is placed on the scale can be determined by the following:

$$\frac{3.0 \text{ mV/V}}{20.000 \text{ kg}} = \frac{\text{Simulator mV/V Setting}}{10.000 \text{ kg}}$$

Therefore, the simulator should be set to 1.5 mV/V.

5. Adjust the indicator to display the capacity of the scale (10,000 kg in our example) and set the indicator's span.
6. Adjust the simulator's output in steps (1.0 mV/V, 0.5 mV/V, 0.0 mV/V) and verify the indicator's linearity and return to zero.
7. Remove the simulator and reconnect the load cells. Recalibrate the indicator's zero point to take account of the actual dead weight of the vessel.
8. The accuracy of this method can be greatly increased by using a high-resolution 5 1/2 digit volt meter to measure the indicator's actual excitation voltage and to verify the actual mV output from the simulator. Those more accurate figures can then be used in the above procedure.

This Page Intentionally Blank.

Appendix

26.0	Units of Measure	98
27.0	Glossary	99

26.0 Units of Measure

Voltage, current and resistance are electrical properties. These properties each have their own units of measure as shown in the chart below.

Unit	Measurement Of	Abbreviation
Volt	Voltage	V
Ohm	Resistance	Ω
Ampere	Current	A

Table 26-1. Units of Measure

Instead of writing out 25 volts, write 25 V; 1 ampere can be written as 1 A; and 100 ohms can be written as 100 Ω . Often these units are too large or small for easy use. For these cases, we can use prefixes to further qualify each unit of measure. Refer to the chart below for the most common prefixes.

Prefix	Symbol	Value	Factor
Mega	M	1,000,000	10^6
Kilo	K	1,000	10^3
Centi	c	.01	10^{-2}
Milli	m	.001	10^{-3}
Micro	μ	.000001	10^{-6}

Table 26-2. Unit of Measure Prefixes

Whole number symbols are represented by upper case letters while fractional number symbols are represented by lower case letters. The symbol for micro is the Greek letter " μ " NOT a lower case "u." Resistance readings can range from millionths of ohms to several million ohms. Let's look at an example of 60,000 ohms and find another way to write it. The prefix for 1,000 is kilo and its symbol is K. The symbol for ohms is Ω . So we can write 60,000 ohms as 60 K Ω . Essentially, we made our value 1,000 times larger. (Ohms to kilohms.)

When working with electronic weighing systems, it is very common to find very low current and voltage levels. A common value is 3 mV. We can also write 3 mV as:

0.003 volts

3 mV

3×10^{-3} volts



NOTE: 10^{-3} is the same as 0.001, 1/1000, $1/10^3$ or $1/(10 \times 10 \times 10)$.

It is sometimes desirable to convert millivolts (mV) to microvolts (μ V). Millivolts are 1,000 times larger than microvolts. So to change millivolts to microvolts we need to multiply the number of millivolts by 1,000. For example:

3 millivolts = $3 \times 1,000$ microvolts

3 mV = 3000 μ V

These two numbers both represent the same values.

27.0 Glossary

A

A/D (Analog to Digital)

Conversion of continuously varying (analog) voltage levels to discrete binary-numbered (digital) values (e.g., a load cell output can be fed through an A/D converter to produce a continuous stream of digitized information and sent to a digital indicator).

ACCUMULATOR

A circuit or register device in a computer that receives, totals and stores numbers.

ACCURACY

Precision in the measurement of quantities and in the statement of physical characteristics. Accuracy is expressed in terms of error as a percentage of the specified value (e.g., 10 volts \pm 1%), as a percentage of a range (e.g., 2% of full scale), or as parts (e.g., 100 parts per million).

AMBIENT CONDITIONS

The conditions (humidity, pressure, temperature, etc.) of the medium surrounding the load cell.

AMPERE

Unit of electrical current intensity. One ampere of current is 6.24×10^{18} electrons passing a point in one second; often shortened to "amp".

ANALOG

Anything that corresponds, point-for-point or value-for-value, to an otherwise unrelated quantity; data represented by continuous values rather than in discrete steps.

ANGULAR LOAD, CONCENTRIC (Common Center)

A load applied concentric with the primary axis at the point of application, and at some angle with respect to the primary axis.

ANGULAR LOAD, ECCENTRIC (Off Center)

A load applied eccentric with the primary axis at the point of application and at some angle with respect to the primary axis.

APERTURE

The total range (in percentage) of full scale capacity over which a digital weight indicator's "Automatic Zero Maintenance" (AZM) and "Push-button Auto Zero" (PAZ) functions will operate; Handbook 44 maximum is +2% of full scale.

APPROVED

Acceptable to the authority having jurisdiction over the area in which a system or equipment will be used.

ASCII (American Standard Code for Information Interchange)

Pronounced "askee." A seven-bit plus parity code established by the American National Standards Institute (ANSI) to achieve compatibility between data services.

ASSOCIATED APPARATUS

Apparatus in which the circuits are not necessarily intrinsically safe themselves, but may affect the energy in the intrinsically safe circuits and are relied upon to maintain intrinsic safety. An associated apparatus has identified intrinsically safe connections for intrinsically safe apparatus and may also have connections for non-intrinsically safe apparatus.

ASYNCHRONOUS TRANSMISSION

Data transmission in which time intervals between transmitted characters may be of unequal length. Transmission is controlled by start bits at the beginning of each character and stop bits at the end of each character.

AUTHORITY HAVING JURISDICTION

Where public safety is primary, the "Authority Having Jurisdiction" may be a federal, state, local or other regional institution, department or individual. Some examples are a fire chief, fire marshal, chief of a fire protection bureau, labor department, health department, building official, electrical inspector or other having statutory authority. For insurance purposes, an insurance inspection department rating bureau or other insurance company representative may be the "Authority Having Jurisdiction".

AIT (Auto Ignition Temperature)

The minimum temperature required for a substance to initiate or cause self-sustained combustion independently of the heating or heated equipment. Also referred to as ignition temperature.

AZM (Automatic Zero Maintenance)

An electronic means of providing "true zero" at all times on a digital scale. AZM compensates for such conditions as indicator or load cell drift or debris on a scale platform by electronically tracking out minor variations around zero; also called "zero tracking".

AVERAGE PIECE WEIGHT (APW)

On a counting scale, the amount of weight divided by the number of samples which comprised that weight. APW is used by the counting scale to count pieces during normal operation.

AXIAL LOAD

A load applied along a line concentric with the primary axis.

B

BAUD

A unit of communications processing speed in digital data communications systems. The speed in baud is the number of discrete conditions of signal events per second. If each signal event represents only one bit condition, baud rate equals bits per second (BPS).

BCD (Binary Coded Decimal)

A data coding system in which four binary bits represent the decimal numbers 0 through 9. The BCD equivalent of the decimal number 187 is 0001 1000 0111.

BEAM

The indicating device of a lever scale.

BEZEL

A holder designed to receive and position the edges of a lens, meter, window or display.

BIDIRECTIONAL

Data flow in either direction on a wire between pieces of equipment. Each equipment item can both receive and transmit data.

BIT

The smallest unit of information in a binary system, consisting of a "0" or a "1" (formed from Binary Digit).

BLACKOUT

A sudden loss of AC line power usually as a result of an overload or other power failure.

BOARD OF GOVERNORS

National Conference on Weights and Measures body of officials that sets NTEP policy and has final say in disputes.

BRIDGE CIRCUIT

A network of four "leg" components connected so that the input signal may be applied across two branches in parallel and the output signal taken between two points, one on each side of the parallel branches. At some ratio of the resultant four arms of the circuit, the output points are at the same potential, and the output voltage is zero. The bridge then is said to be balanced or set to null.

BROWNOUT

A deliberate lowering of line voltage by a power company to reduce load demands.

C

CALIBRATION

The comparison of load cell outputs against standard test loads.

CALIBRATION CURVE

A record (graph) of the comparison of load cell outputs against standard test loads.

CANTILEVER BEAM

A beam-type load cell that has a machined-out center. The load sensing elements (strain gauges) are mounted on the inside perimeter of this machined center.

CAPACITANCE

The ability of a component or material to store an electrostatic charge; measured in farads. Because the farad is a very large quantity, capacitance in electronic applications is usually expressed in millionths of a farad (microfarads) or millionths of a millionth of a farad (pico farads).

CERMET

An alloy of ceramic and metal, usually titanium carbide and nickel, used as a resistance element in some variable resistors; acronym of ceramic metal.

CHECK RODS

Rods installed to prevent a vessel or other weighing system component from gross tipping or extended travel. They do not interfere with normal travel or expansion.

CHECKWEIGHER

A scale used to verify predetermined weight within prescribed limits.

CLASS III

Classes of scales used in commercial weighing not otherwise specified; grain test scales, retail precious metals and semiprecious gem weighing, animal scales, postal scales, and scales used to determine laundry charges.

CLASS IIII

Vehicle, axle-load, livestock, railway track scales, crane and hopper (other than grain hopper) scales.

CLC (Concentrated Load Capacity)

Maximum load designated by the manufacturer that can be placed anywhere on the platform of a vehicle, axle-load or livestock scale using the prescribed test pattern (an area at least 4 feet long and as wide as the scale platform).

CMOS (Complementary Metal Oxide Semiconductor)

Chip technology characterized by a low power requirement and a high noise immunity. CMOS chips are susceptible to damage by electrostatic discharge (ESD).

CC (NTEP Certificate of Conformance)

Certification that a device meets all applicable requirements of Handbook 44.

COMBINED ERROR (Non-linearity and Hysteresis)

The maximum deviation from the straight line drawn between the original no-load and rated load outputs expressed as a percentage of the rated output and measured on both increasing and decreasing loads.

COMPENSATION

The utilization of supplementary devices, materials or processes to minimize known sources of error.

COMPRESSION

A force applied to a strain gauge that causes the gauge wires to compress and their cross-sectional area to increase, thus decreasing the gauge resistance.

CONFORMALLY COATED

Refers to load cells which have a protective coating applied over the strain gauges, terminal strip, etc., within the gauged cavity. The cavity opening may additionally be covered with side plates to protect against physical damage. These cells are suitable for normal indoor applications; they should not be used in wet or washdown applications.

CONTINUOUS MODE

Transmission of serial output data in which the data is transmitted automatically following each indicator display update; usually used to interface indicators to computers, score boards and other remote devices requiring constant data updating.

CONTROL DRAWING

A drawing or document provided by the manufacturer of the intrinsically safe or associated apparatus that details the allowed interconnections between the intrinsically safe and associated apparatus.

CPU (Central Processing Unit)

The computer module or chip that controls fetching, decoding and executing instructions; controls processing operations for the device.

CREEP

The change in load cell output occurring with time, while under load, and with all environmental conditions and other variables remaining constant; usually measured with Rated Load applied and expressed as a percent of Rated Output over a specific period of time.

CREEP RECOVERY

The change in no-load output occurring with time, after removal of a load which has been applied for a specific period of time; usually measured over a specified time period immediately following removal of rated load and expressed as a percent of rated output.

CURRENT

Flow of electrons past a point in a specified period of time; measured in amperes.

CURRENT LOOP

A current-based method of serial communications between digital devices; a logic high is represented by current flowing in the loop; a logic "low" is represented by a lack of current flowing in the loop.

D**d (Division)**

Value of the smallest increment indicated (displayed) by a scale.

DASH POT

A dampening device used to reduce scale oscillations.

DEAD LOAD

The fixed force of the weighbridge, platform, and other load-supporting structures of the scale, the value of which is to be permanently balanced or cancelled out in the weight or measuring system.

DEFLECTION

The change in length along the Primary Axis of the load cell between no-load and Rated Load conditions.

DEMAND MODE

Transmission of serial output data which requires a manual "Print" command to initiate the output data. Usually used to interface indicators to printers.

DIGITAL

System of signal representation employing discrete rather than continuously variable (analog) values.

DIGITAL AVERAGING

The ability of a digital indicator to smooth bouncy or erratic readings by taking several readings and averaging them together before sending the signal to the display. Increasing the digital averaging slows the indicator's update rate.

DIP (Dual In-line Package)

An integrated circuit contained within a standard housing characterized by its low profile, rectangular body, and symmetrical placement of leads along two opposing sides of the device.

DORMANT SCALE

A built-in scale having a self-contained under structure.

DOT MATRIX

A method of printing in which a rectangular array (matrix) of spaces are filled in to form alphanumeric and punctuation characters.

DRIBBLE

In filling operations, the weight value over which material is slowly handled to provide a more accurate cutoff.

DRIF

A random change in output under constant load conditions.

DROPOUT

A temporary loss of electrical power normally caused by utility and maintenance switching functions where break-before-make switching strategies are used.

E

e (Verification Scale Division)

Value of a verification scale division specified by the manufacturer; sets value for tolerances and accuracy class.

e_{\min} (Minimum Verification Scale Divisions)

The minimum scale division or value for which a device complies with applicable requirements, e.g., bench or counter scale.

ECCENTRIC LOAD

Any load applied parallel to, but not concentric with, the Primary Axis.

EEPROM (Electrically Erasable Programmable Read Only Memory)

A data storage component whose data can be repeatedly read out; the stored data can be erased by an electrical signal and new data then can be programmed into the component.

ELECTRICAL NOISE

Extraneous undesirable currents or voltages which interfere with desirable electrical quantities. Some causes are distant lightning, radio transmitters, welding equipment, electrical switching equipment, poor brush contact on motors, and other electronic devices utilizing switching power supplies.

ELECTRON

A negatively-charged subatomic particle that orbits the nucleus of an atom. Electrical current is the flow of electrons.

ELECTROSTATIC CHARGE

An electric charge on the surface of an insulated object.

EMI (Electromagnetic Interference)

Interference caused by electrical fields due to capacitive coupling, or magnetic fields due to mutual inductance of electromagnetic fields (radio waves).

ENVIRONMENTALLY PROTECTED

Refers to load cells which have a strain gauge cavity filled with a potting compound. The cavity opening is also generally protected with loose-fitting side plates or molded plastic to protect against physical damage. These cells are protected from normal environmental factors in indoor or outdoor applications. They should not be submersed or washed down.

EPROM (Erasable Programmable Read Only Memory)

A data storage component whose data can be repeatedly read out; the stored data can be erased by applying ultraviolet light, and new data then can be programmed into the component.

ERROR

The algebraic difference between the indicated and true value of the load being measured.

ESD (Electrostatic Discharge)

A rapid discharge of an electrostatic potential that can cause damage to integrated circuits.

EXCITATION

The voltage or current applied to the input terminals of the load cell. Most load cells have a rated excitation voltage of 10 VDC. There are load cells available that are rated at 15, 20 and 25 VDC and also some that have both AC and DC excitation ratings.

EXCITATION TRIM

Method of matching load cell outputs in a multicell system by adjusting the excitation voltage to each individual load cell. Adjustment is made by changing the setting of a variable resistor in series with the excitation input.

EXPLOSION PROOF ENCLOSURE

An enclosure that is capable of withstanding an explosion of a specified gas or vapor which may occur within it, and of preventing the ignition of the gas surrounding the enclosure. The enclosure also must operate at such an external temperature so that it is incapable of igniting its surrounding atmosphere.

F

FACTORY MUTUAL (FM) SYSTEM APPROVED

All products displaying this symbol have been approved for use in hazardous (classified) locations when following the proper installation procedures and drawings, and utilizing intrinsic safety barriers.

FLEXURES

Thin steel or plastic bands or plates which replace the pivots and bearings of a conventional scale, allowing less movement and reducing friction.

FULCRUM

A pivot point for a lever.

FULL DUPLEX

Simultaneous, two-way, independent data transmission in both directions.

G

GATED POWER SUPPLY

A power supply that allows conduction only when signal magnitude is within specified limits.

GRADUATION

A mark on an instrument or vessel indicating degrees or quantity.

H

HALF DUPLEX

Data transmission in both directions, but not simultaneously (see Full Duplex).

HANDBOOK 44 (H-44)

A comprehensive set of requirements for weighing and measuring devices that are used in commerce and law enforcement activities; not a federal law, but developed and updated annually by the National Conference on Weights and Measures. Its complete title is "Specifications, Tolerances, and Other Technical Requirements for Weighing and Measuring Devices."

HANDSHAKING

Exchange of predetermined signals between two devices for purpose of control.

HAZARDOUS (CLASSIFIED) LOCATION

A location where fire or explosion hazards may exist due to the presence of flammable gases or vapors, flammable liquids, combustible dust or easily-ignitable fibers or flyings.

HERMETICALLY SEALED

Refers to load cells which have a metallic protective cover welded or soldered in place to protect the strain gauge cavity. Some cells of this type have additional protection at the cable entry such as a glass-to-metal seal. These load cells provide the best possible protection in harsh chemical or washdown environments.

HIGH PASS FILTER

A filter passing frequency components above a designated frequency and rejecting components below that frequency.

HYSTERESIS

The maximum difference between load cell output readings for the same applied load. One reading is obtained by increasing the load from zero and the other reading is obtained by decreasing the load from rated load. Measurements should be taken as rapidly as possible to minimize creep. Hysteresis is measured as percentage of the full scale rated output (% F.S.). Common load cell hysteresis values are 0.02% F.S., 0.03% F.S. and 0.05% F.S.

I

INFLUENCE FACTORS

Environmental elements that may alter or interrupt an electronic or mechanical indication (e.g., temperature, humidity, radio frequency interference, barometric pressure, electric power).

INPUT BRIDGE RESISTANCE

The input resistance of the load cell. It is measured by placing an ohmmeter across the input or excitation leads. It is usually higher than the output bridge resistance because of the presence of compensating resistors in the excitation circuit.

INTERFACE

A device or circuit that allows two units to communicate. Some of the standard interfaces used in the scale industry are 20 mA current loop, BCD, RS-232, RS-422 and RS-485.

INTRINSICALLY SAFE CIRCUIT

A circuit in which any spark or thermal effect is incapable of causing ignition of a mixture of flammable or combustible material in air under prescribed test conditions in its most easily ignitable concentration.

INTRINSICALLY SAFE SYSTEM

An assembly of interconnected intrinsically safe apparatus, associated apparatus and interconnecting cables in which the parts of the system, which may be used in hazardous (classified) locations, are intrinsically safe circuits; may include more than one intrinsically safe circuit.

INTRINSIC SAFETY BARRIER

A network designed to limit the energy (voltage and current) available to the protected circuit in the hazardous (classified) location under specified fault conditions.

INTRINSIC SAFETY GROUND BUS

A grounding system that has a dedicated conductor, separate from the power system, so ground currents will not normally flow, and which is reliably connected to a ground electrode in accordance with Article 200 of the NEC.

INSULATION RESISTANCE

The DC resistance measured between the load cell circuit and the load cell structure; normally measured at 50 volts DC and under standard test conditions.

INGRESS PROTECTION (IP) RATING

A rating system that defines a product's or enclosure's protection against the ingress of solid objects and liquids. See page 9 for a chart defining the IP rating system.

I/O (Input/Output)

The circuits or devices that allow a digital unit to send (output) data and receive (input) data.

J**J-BOX (Junction Box)**

A box or enclosure used to join different runs of cable or wiring; it contains space and terminals for connecting and branching the enclosed conductors and adjustments to provide load cell trimming.

L**LATCH**

To maintain a closed (energized) state in a pair of relay contacts after initial energization from a single electrical pulse.

LATCHING RELAY

A relay which locks into the mode for which it is energized (On or Off); requires a start-stop button; once activated it stays activated until the setpoint is reached or the stop button is pushed.

LED (Light Emitting Diode)

A semiconductor light source that emits visible light or invisible infrared radiation.

LEVER

A tool that transfers force equally with reduction or multiplication.

LIVE LOAD

The load applied to a scale base that is actually being measured by the weighing system.

LOAD

The weight or force applied to the load cell.

LOAD CELL

A device which produces an output signal proportional to the applied weight or force. Types of load cells include beam, S-beam, platform, compression and tension.

LOW PASS FILTER

A filter which passes frequency components below a designated frequency and rejecting components above that frequency.

M**MASS**

The quantity of matter in a body.

MEGOHMMETER

A special ohmmeter for measuring resistances in the megohm (10⁶ ohms) range; also called a megger.

METAL FILM RESISTOR

A fixed or variable resistor in which the resistance element is a thin or thick film of a metal alloy deposited on a substrate made of plastic or ceramic material.

MICRO

A prefix meaning millionths (10⁻⁶); symbol is "μ".

MICROVOLTS PER GRADUATION

The number of microvolts of live load signal that are needed to change the display.

MINIMUM DEAD LOAD - Load Cells

Minimum dead load is specified for NTEP load cells. In a given application, the dead load applied to each cell must be greater than or equal to the minimum dead load specified by the load cell manufacturer.

MOTION DETECTION

A circuit used in an indicator to sense when the displayed weight data is changing at a greater rate than preset limits (or is unstable) and to inhibit certain functions during this time. Functions inhibited may be data output, entry of a push-button auto zero, entry of an auto tare value or activation of zero tracking.

MOV (Metal Oxide Varistor)

A voltage-dependent resistor whose resistance predictably changes with voltage applied; used in transient protectors as a shunt protection device.

N**n_{max} (Maximum Number of Scale Divisions)**

The maximum number of scale divisions for which a product has been approved. The n_{max} must be greater than or equal to the number of divisions for which the scale will be configured.

NEGATIVE LOGIC

Binary logic in which a high negative state represents a "1" condition and a low negative state represents a "0" state.

NEMA

National Electrical Manufacturers Association.

NCWM (National Conference on Weights and Measures)

An association of state and local officials. Federal and industry representatives that adopt uniform (model) laws and regulations (e.g., NIST Handbook 44).

NIST (National Institute for Standards and Technology)

An agency of the federal government to which all precision measurements are traceable. Formerly the National Bureau of Standards (NBS)

NOMINAL LOAD CAPACITY

The designed normal maximum load cell capacity. Output load cell sensitivity is based on this capacity unless otherwise specified.

NON-LATCHING RELAYS

Relays that will stay at the logic level based on the current setpoint data. These relays will "toggle" from energized to de-energized states depending on the signal sent to them.

NON-LINEARITY

The maximum deviation of the calibration curve from a straight line drawn between the no-load and rated load outputs. It is expressed as a percentage of the full-scale rated output. It is measured on an increasing load only. Common non-linearity values are 0.02% F.S. and 0.03% F.S.

NONVOLATILE MEMORY

A computer storage medium whose contents remain unaltered when the power is switched off; contents are available when power is switched on again.

NTEP (National Type Evaluation Program)

A program of cooperation between the National Conference On Weights & Measures, NIST, state weights and measures officials and the private sector for determining conformance of weighing equipment with the provisions of H-44.

O**OEM (Original Equipment Manufacturer)**

A manufacturer who produces equipment for use or inclusion by another manufacturer in its product.

OHM

The unit of electrical resistance. The resistance through which a current of one ampere will flow when a voltage of one volt is applied.

OHM'S LAW

The relationship between current, voltage and resistance. Current varies directly with voltage, and inversely with resistance ($I = E/R$, where I = Current, E = Voltage and R = Resistance).

OUTPUT

The signal produced by the load cell where the output is directly proportional to excitation and the load applied. The signal must be in terms such as millivolts per volt (mV/V) or volts per ampere (V/A).

OUTPUT BRIDGE RESISTANCE

The output resistance of the cell. It is measured by placing an ohmmeter between the signal or output leads. Common bridge resistances are 350 Ω , 480 Ω , 700 Ω , 750 Ω and 1000 Ω .

OUTPUT, Rated

The algebraic difference between the outputs at no-load and at rated load.

OVERLOAD RATING, Safe

The maximum load, in percent of Rated Capacity, which can be applied without producing a permanent shift in performance characteristics beyond those specified.

OVERLOAD RATING, Ultimate

The maximum load, in percent of Rated Capacity, which can be applied without producing a structural failure.

OWM

Office of Weights and Measures at NIST.

OIML (International Organization of Legal Metrology)

Treaty organization that recommends technical requirements for weighing and measuring equipment prior to the sale or distribution of a model or type within the state, nation, etc.

P**PARALLEL CIRCUIT**

A circuit in which the components are connected across each other. The voltage applied to each component is the same.

PARALLEL COMMUNICATIONS

Type of data communication in which all elements in an information item (bits, in a word) are acted upon simultaneously, rather than one at a time as in serial communications.

PARITY

A method of error checking where an extra bit is sent to establish an even or odd number of ones in the data of a character.

PAZ (Push-button Auto Zero)

Extension of the AZM function of a digital weight indicator through the use of a frontpanel push-button.

POISE

A moveable weight that counterbalances the load on a scale.

PORT

A point at which signals may be introduced to or extracted from a circuit, device, or system.

POTENTIOMETER

A variable resistor employed as a voltage divider.

POTTED CELL

A load cell which is environmentally sealed by filling the strain gauge cavity with a material that protects the gauges from environmental hazards such as moisture. The potting material must not interfere with normal strain gauge movement, and allow the gauges to return to their normal zero output position.

PRACT

Weight value which is set to allow for material in suspension during a filling operation.

PRESSURIZATION

The process of supplying an enclosure with clean air or an inert gas with or without continuous flow at sufficient pressure to prevent the entrance of combustible dust.

PRIMARY AXIS

The axis along which the load cell is designed to be loaded; normally its geometric center line.

PROTECTIVE COMPONENT

A component or assembly which is so unlikely to become defective in a manner that will lower the intrinsic safety of the circuit that it may be considered not subject to fault when analysis or tests for intrinsic safety are made.

PURGING

The process of supplying an enclosure with clean air or an inert gas at sufficient flow and positive pressure to reduce, to an acceptable safe level, the concentration of any flammable gases or vapors initially present, and to maintain this safe level by positive pressure with or without continuous flow.

R

RACEWAY

An enclosed channel designed for holding wires, cables, or busbars.

RAINPROOF

An enclosure so constructed, protected, or treated, as to prevent rain from interfering with the successful operation of the apparatus under specified test conditions.

RAINTIGHT

An enclosure so constructed or protected that exposure to a beating rain will not result in the entrance of water under specified test conditions.

RAM (Random Access Memory)

A data storage device that can be accessed in any order. It is known as a read/write memory, as information can be written into the memory, then read out when needed by the microprocessor. The contents of RAM are lost when the system is powered down.

REACTANCE

The opposition offered to the flow of alternating current by pure capacitance, pure inductance, or a combination of the two. Its unit is the "ohm".

REFERENCE STANDARD

A force-measuring device whose characteristics are precisely known relative to a primary standard.

REMOTE SENSING

A method of regulating the excitation voltage to the load cells. Some indicators compensate for voltage drops occurring between the indicator and load cells by increasing the indicator excitation output voltage; other indicators compensate for this voltage drop by amplifying the load cell return signal.

REPEATABILITY

The maximum difference between load cell output readings for repeated loadings under identical loading and environmental conditions; the ability of an instrument, system, or method to give identical performance or results in successive instances.

RESISTANCE

Opposition to current flow offered by a purely resistive component; simple opposition to current flow. Measured in ohms. See REACTANCE.

RESISTIVITY

The electrical resistance offered by a unit cube of material to the flow of direct current between opposite faces of the cube. It is measured in "ohm-centimeters."

RESOLUTION

The smallest change in mechanical input which produces a detectable change in the output signal.

RFI (Radio Frequency Interference)

Radio frequency energy of sufficient magnitude to possibly affect operation of other electrical equipment.

ROM (Read Only Memory)

A memory unit in which instructions or data are permanently stored for use by the machine or for reference by the user. The stored information is read out non-destructively and no information can subsequently be written into the memory.

RS-232

A voltage-based serial method of data communication used to transfer data between digital devices. Two wires carry the data; one wire is signal ground, and several control wires may be used for handshaking. A logic "high" is from -3 to -25 volts and a logic "low" is from +3 to +25 volts. Transmission distance should be restricted to 50 feet.

S

SAFE OVERLOAD RATING

The maximum load, in percent of Rated Capacity, which can be applied without producing a permanent shift in performance characteristics beyond those specified. A common safe overload rating is 150% F.S.

SAFETY FACTOR

A figure denoting the overload (and allowance thereof) a device can withstand before breaking down.

SCALE

A device for weighing, comparing and determining weight or mass.

SENSITIVITY

The ratio of the change in output to the change in mechanical input.

SERIAL TRANSMISSION

A method of data transmission in which each bit of information is sent sequentially on a single channel.

SETPOINT

In a feedback control loop, the point which determines the desired value of the quantity being controlled.

SHEAR BEAM

A bending beam load cell in which the strain gauges are mounted on a thin web of material in a machined-out cavity in the load cell.

SHIFT TEST

A test intended to disclose the weighing performance of a scale under off-center loading.

SHOCK LOAD

A sudden increase in load usually caused by dropping weight onto the scale. Can cause permanent load cell damage.

SIDE LOAD

Any load acting 90° to the primary axis at the point of axial load applications.

SIGNAL TRIM

A method of matching load cell outputs in a multicell system by adjusting the output signal voltage through a variable resistor placed across the signal leads.

SIP (Signal In-Line Package)

A flat, molded component package having terminal lugs along one side; half of a dual inline package (DIP).

SPAN

The difference between the highest value and the lowest value.

STABILIZATION PERIOD

The time required to ensure that any further change in the parameter being measured is tolerable.

STACK

A temporary storage area in a computer memory consisting of a small group of registers. Data stored in the stack is retrieved from the stack in reverse order in which it is stored.

STANDARD TEST CONDITIONS

The environmental conditions under which measurements should be made, when measurements under any other conditions may result in disagreement between observers at different times and places. The conditions are as follows: Temperature: $72^{\circ}\text{F} \pm 3.6$ ($23^{\circ}\text{C} \pm 2$) Barometric Pressure: 28 to 32 inches Hg.

STATIC OVERLOAD CAPACITY

Capacity as a percentage of nominal load limit capacity, in which the load cell can safely be loaded to this limit with no adverse affect on the performance or any change in its zero balance or other specifications.

STAY RODS

Rods installed to rigidly restrain a vessel or other weighing system component in the horizontal position. They will have little effect on the accuracy of the system when installed properly.

STRAIN GAUGE

A device for detecting the strain that a certain force produces on a body. The gauge consists of one or more fine wires cemented to the surface under test. As the surface becomes strained, the wires stretch or compress, changing their resistance. Several strain gauges are used to make up a load cell.

T**TARE**

The weight of an empty container or vehicle, or the allowance or deduction from gross weight made on account thereof.

TEMPERATURE COEFFICIENT

A figure which states the extent to which a quantity drifts under the influence of temperature.

TEMPERATURE EFFECT, On Rated Output

The change in rated output due to a change in ambient temperature. It is usually expressed as the percentage change in rated output per 100°F (37°C) change in ambient temperature.

TEMPERATURE EFFECT, On Zero Balance

The change in zero balance due to a change in ambient temperature. It is usually expressed as the change in zero balance in percent of rated output per 100°F (37°C) change in ambient temperature.

TEMPERATURE RANGE, Compensated

The range of temperature over which the load cell is compensated to maintain rated output and zero balance within specific limits.

TEMPERATURE RANGE, Safe

The extremes of temperatures within which the load cell will operate without permanent adverse change to any of its performance characteristics.

TERMINAL RESISTANCE, Corner to Corner

The resistance of the load cell circuit measured at specific adjacent bridge terminals at standard temperature with no load applied and with the excitation and output terminals open-circuited.

TERMINAL RESISTANCE, Input (Excitation)

The resistance of the load cell circuit measured at the excitation terminals at standard temperature with no load applied and with the output (signal) terminals open-circuited.

TERMINAL RESISTANCE, Output (Signal)

The resistance of the load cell circuit measured at the output signal terminals at standard temperature with no load applied and with the excitation terminals open-circuited.

TOLERANCE

The amount of error that is allowed in a value. It is usually expressed as a percent of nominal value, plus or minus so many units of measurement.

TRACEABILITY

The step-by-step transfer process by which the load cell calibration can be related to primary standards.

TRANSDUCER

A device that converts energy from one form to another.

TRANSIENT

A momentary surge on a signal or power line. It may produce false signals or triggering impulses and cause insulation or component breakdowns and failures.

TRIAC

A three-terminal, gate controlled, bidirectional silicon switching device that can switch either alternating or direct currents.

TRIM

To make a fine adjustment, as of load cell outputs in a multicell system.

U

ULTIMATE OVERLOAD RATING

The maximum load, in percent of Rated Capacity, which can be applied to a load cell, without producing a structural failure.

V

v_{\min} (Minimum Verification Scale Division/Load Cell)

A parameter used to select load cells for NTEP approved applications. For single cell applications, v_{\min} must be less than or equal to the scale division size; for mechanical scale conversions using one load cell, v_{\min} must be less than or equal to the scale division size divided by the scale multiple. For a scale using more than one load cell, v_{\min} must be less than or equal to the scale division divided by the square root of the number of cells.

VOLATILE MEMORY

A computer storage medium whose contents are lost when there is a loss of power.

VOLT

The unit of voltage, potential difference and electromotive force. One volt will send a current of one ampere through a resistance of one ohm.

VOLTAGE

The electrical potential difference that exists between two points and is capable of producing a flow of current when a closed circuit is connected between the two points.

VOLTAGE DIP

A temporary decrease in voltage level lasting at least one alternating current cycle.

VOLTAGE SPIKE

Large damaging voltage pulse caused when lightning strikes a power line, communication line, a signal or sensing line, or even the ground nearby.

VOLTAGE SURGE

A temporary rise in voltage level lasting at least one alternating current cycle.

W

WATER-PIPE GROUND

An earth connection made by running a strong wire to the nearest cold water pipe.

WATER TIGHT

An enclosure so constructed that moisture will not enter the enclosure under specified test conditions.

WEATHER PROOF

An enclosure so constructed or protected that exposure to the weather will not interfere with successful operation of its contained equipment.

WEIGHT

The force or amount of gravitational pull by which an object or body is attracted toward the center of the earth.

Z

ZENER DIODE

A semiconductor diode which is used in the reverse biased condition. It exhibits a nondestructive breakdown at a predetermined reverse voltage, so while the diode is operating in this breakdown region, an increase in current flow through the diode will not result in increased voltage drop across the diode. It is used in voltage regulation circuits and as a voltage limiting device in intrinsic safety barriers.

ZERO BALANCE

The output signal of the load cell with rated excitation and with no load applied, usually expressed in percent of rated output.

ZERO RETURN

The difference in Zero Balance measured immediately before Rated Load application of specified duration, measured after removal of the load, and when the output has stabilized.

ZERO SHIFT, Permanent

A permanent change in no-load output.

ZERO STABILITY

The degree to which the load cell maintains its Zero Balance with all environmental conditions and other variables remaining constant.

Rice Lake continually offers web-based video training on a growing selection of product-related topics at no cost.

www.ricelake.com/webinars

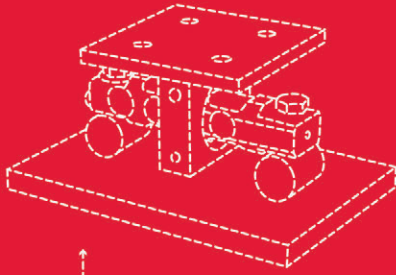

Check out our website
www.ricelake.com/lcwm

for this handbook and more helpful
information on load cells and weigh
modules



RICE LAKE[®]
WEIGHING SYSTEMS

230 W. Coleman St. • Rice Lake, WI 54868 • USA

USA: 800-472-6703 • Canada/Mexico: 800-321-6703 • Direct: 715-234-9171 • FAX: 715-234-6967 • **www.ricelake.com**

© 2024 Rice Lake Weighing Systems • PN 22054 Rev E • January 24, 2024
Specifications subject to change without notice