



NATIONAL TYPE EVALUATION PROGRAM

# Certificate of Conformance

for Weighing and Measuring Devices

**For:**

Weighing/Load Receiving Element  
Electromechanical Pipe Lever System  
Models: PLS-XXYY-ZZK\* and PLS-25-Y\*\*  
 $n_{max}$ : (see page 2)  
 $e_{min}$ : (see page 2)  
Capacity: 5 000 lb to 60 000 lb (see page 2)  
Platform: (see page 2)  
Accuracy Class: III / III L

**Submitted By:**

Rice Lake Weighing Systems  
230 W. Coleman St.  
Rice Lake, WI 54868  
Tel: 715-234-9171  
Fax: 715-234-6967  
Contact: Paul A. Lewis, Sr.  
Email: [plewis@ricelake.com](mailto:plewis@ricelake.com)  
Web site: [www.ricelake.com](http://www.ricelake.com)

**Standard Features and Options**

Pipe lever Weighing Element: designed for use with compatible load receiving elements using the PLS designed mounting system including: Hopper, tank, and steel deck, which have been adapted to fit on pipe lever system.

Weighing/Load Receiving Element: Type approved and certified as a steel deck platform scale and as a livestock scale with a steel-framed wood deck. See page 2 for parameters for approved lever dimensions, steel deck platform sizes, and livestock scale platform sizes.

**Option:**

- Stainless Steel Construction

**\*PLS-XXYY-ZZK, Where:**

- XXYY = the dimension of the load receiving element to the nearest inch,
- ZZ = the capacity in thousands of pounds, and
- LS suffix = livestock-weighing option with 2-section wood platform and stock racks
- \*\* PLS-25-Y, Where:
- 25 = 25 000 lb capacity, and
- Y = code number used to represent the dimension of the load receiving element

**Livestock Scales:**

- Section capacity is equal to scale capacity.
- Level indicating means provided on frame of lever system for portable applications.

**Load Cell Used:**

- One (1) Rice Lake RL20000A Series (CC No. 90-158), RL20000B Series (CC No. 98-044) for the LS option, or a metrologically equivalent NTEP certified load cell.

**Installations must satisfy the relationship of  $v_{min} \leq d / (\sqrt{N} \times \text{scale multiple})$  where N= number of load cells.**

Temperature Range: -10 °C to 40 °C (14 °F to 104 °F)

This device was evaluated under the National Type Evaluation Program and was found to comply with the applicable technical requirements of "NIST Handbook 44: Specifications, Tolerances and Other Technical Requirements for Weighing and Measuring Devices." Evaluation results and device characteristics necessary for inspection and use in commerce are on the following pages.

  
Tim Tyson  
Chairman, NCWM, Inc.

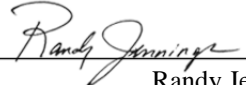
  
Randy Jennings  
Chairman, National Type Evaluation Program Committee  
Issued: November 16, 2010

1135 M Street, Suite 110 / Lincoln, Nebraska 68508

The National Conference on Weights and Measures (NCWM) does not approve, recommend or endorse any proprietary product or material, either as a single item or as a class or group. Results shall not be used in advertising or sales promotion to indicate explicit or implicit endorsement of the product or material by the NCWM.

**Rice Lake Weighing Systems**

Weighing/Load Receiving Element / PLS-XXYY-ZZK and PLS-25-Y

<b>Specific capacities, <math>e_{min}</math> and <math>n_{max}</math> values, and platform information.</b>				
<b>Model Number</b>	<b><math>e_{min}</math> (lb)</b>	<b><math>n_{max}</math></b>	<b>Capacity (lb)</b>	<b>Platform Size</b>
PLS-25-Y	10	2500	25 000	*60.5" to 66.5" (w) x 62 5/8" to 105" (l) (not to exceed 45.2 ft <sup>2</sup> )
PLS-XXYY-ZZK	1.0 to 10	5000	5000 to 50 000	*36" to 120" (w) x 36" to 120" (l) (not to exceed 100 ft <sup>2</sup> )
PLS-XXYY-ZZK	1.0 to 10	6000	5000 to 60 000	Dependent upon hopper/tank load receiver.
PLS-XXYY-ZZK-LS	5	4000	10 000 to 20 000	*48" to 84" (w) x 96" to 240" (l) (not to exceed 140 ft <sup>2</sup> )

\*Length or width can be increased by 125% not to exceed maximum platform area.

**Application:** For general purpose Class III platform, Class IIIL livestock scale or Class III/III L tank or hopper scale applications.

**Identification:** The required information is on a metal identification plate that is riveted on the side of one of the levers or on an adhesive label that is on the side of one of the levers.

**Sealing:** There are no sealable parameters on the load-receiving element. Security seal is applied to the indicating element per manufacturer specifications.

**Test Conditions:** This Certificate supersedes Certificate of Conformance No. 94-126A3 and is issued to increase the maximum capacity to 60 000 lb for hopper/tank scale weighing elements based upon testing by NTEP. For the purpose of this evaluation, a Yargus Model TWH 120 in x 114 in x 159 in, 60 000 x 10 lb hopper scale (Certificate of Conformance No. 08-003) was mounted on a Rice Lake Model PLS weighing element and interfaced with a Rice Lake Model 390HE indicating element (Certificate of Conformance No. 98-203). The emphasis of the evaluation was on the design, operation, marking requirements and performance. For the test, 24 000 lb of known test weight and 36 000 lb of material (potash) was used to conduct several increasing/decreasing load and substitution tests to capacity. The scale was sealed and 300 weighments were made over a 21 day period. All weighments were at least 20% of capacity and half of the weighments were over 50% of capacity. The increasing/decreasing load and substitution tests were repeated. Previous test conditions are listed below for reference.

**Certificate of Conformance 94-126A3:** This Certificate supersedes Certificate of Conformance No. 94-126A2 and is issued to include the LS option for livestock weighing. The emphasis of the evaluation was on the device design and operation. For the purpose of this evaluation, the Model PLS-84240-20K-LS (7' x 20' / 20 000 lb x 5 lb) weighing element was interfaced with a Rice Lake Model IQ+355 indicating element (CC No. 97-130A2). The load cell used was Rice Lake Model RL20000B (Certificate of Conformance No. 98-044A1). The initial evaluation included discrimination tests, increasing/decreasing distributed load tests using 20 000 lb of test weights, corner tests at 5 000 lb, and shift tests at 5000 lb. The device was sealed to meet the minimum use requirements of 20 days and 300 weighments of livestock. Permanence testing consisted of discrimination tests, increasing/decreasing distributed load test using 20 000 lb of test weights, and shift tests over corners using 5 000 lb of test weights.

**Certificate of Conformance Number 94-126A2:** This Certificate supersedes Certificate of Conformance Number 94-126A1 and is issued to clarify the platform sizes that are covered by this Certificate. No testing was performed.

**Certificate of Conformance Number 94-126A1:** This Certificate superseded Certificate of Conformance Number 94-126 and was issued to include new platform sizes and capacities. The emphasis of the evaluation was on the device design, operation, and marking requirements. The Models PLS-6060-5K and PLS-120120-50K were used for the purpose of this evaluation. The devices were interfaced with a RLWS IQ+310 indicator (Certificate of Conformance Number 91-132A2) and Rice Lake Model RL20000A (Certificate of Conformance Number 90-158) load cell. Several increasing/decreasing load, shift and corner tests were performed. The scale was used for over 30 days with the minimum use criteria required by NTEP then tested again.

**Certificate of Conformance Number 94-126:** The Model PLS-25-6 was installed with a RLWS IQ+810 indicator and a Rice Lake Model RL20000A load cell for field evaluation. Four increasing/decreasing load tests to scale capacity, two shift tests at one-half capacity, and two corner tests at one-fourth capacity were conducted. Two increasing/decreasing load tests to scale capacity, one shift test at one-half capacity, and one corner test at one-fourth capacity were conducted approximately 30 days later.



## Rice Lake Weighing Systems

Weighing/Load Receiving Element / PLS-XXYY-ZZK and PLS-25-Y

**Evaluated By:** W. West (OH) & M. Buccelli (MN) 94-126, 94-126A1; D. Onwiler (NE) 94-126A3; T. Lucas (OH) 94-126A4

**Type Evaluation Criteria Used:** NIST, Handbook 44: Specifications, Tolerances and Other Technical Requirements for Weighing and Measuring Devices, 2010. NCWM, Publication 14: Weighing Devices, 2010.

**Conclusion:** The results of the evaluation and information provided by the manufacturer indicate the device complies with applicable requirements.

**Information Reviewed By:** W. West (OH) 94-126A2; S. Patoray, L. Bernetich (NCWM) 94-126A3; J. Truex (NCWM) 94-126A4

### Examples of Device:

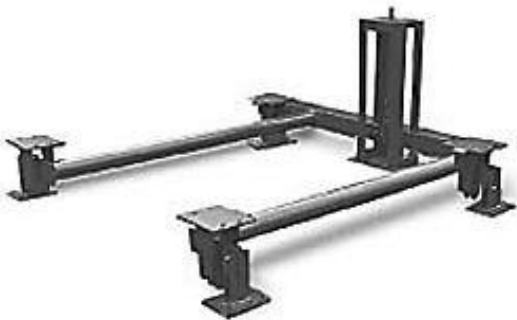

Pipe Lever



LS-Livestock Option