

# Retail

---

## TABLE OF CONTENTS

<b>Retail</b> .....	<b>903</b>
<b>Rice Lake RS-130/RS-160</b> .....	<b>904</b>
<i>Battery-operated Price Computing Scales</i>	
<b>Ishida Astra II</b> .....	<b>905</b>
<i>Price Computing Scale with Printer</i>	
<b>Ishida Astra II</b> .....	<b>907</b>
<i>Standard Label Formats</i>	
<b>Rice Lake BenchPro™ BP-R</b> .....	<b>908</b>
<i>Retail Digital Bench Scale</i>	
<b>QuikSharp™</b> .....	<b>910</b>
<i>Sharpener</i>	
<b>Weight Set</b> .....	<b>910</b>
<i>ASTM Class 5 Stainless Steel Satin 30lb kit</i>	

Product names, logos, brands and other trademarks featured or referred to within this publication are the property of their respective trademark holders.

# Rice Lake RS-130/RS-160

Battery-operated Price Computing Scales



RS-130 Pole



RS-160 Bench

## Standard Features

- Toggle between lb/kg/oz\*
- PLU keys for direct price lookups
- Cash back calculation
- Large stainless steel platter
- In-use cover
- Pole swivels to face desired direction
- Battery charge indicator
- Internal sealed battery
- Customer display

\*Not Measurement Canada Approved

## Specifications

### Power:

Battery (rechargeable): 6 VDC, 25 mA  
A dapter: 115 VAC, 0.1 A max (included)

### Battery Life:

100+ hours, 8 to 10 hours to recharge

### Resolution:

Display: 3,000 divisions maximum

### Annunciators:

Net, zero, kg, lb, oz, change due, cash received

### Display:

LCD backlit, 0.45 in (11.5 mm)

### Display Items:

Weight: Five-digits  
Unit price: Five-digits  
Total price: Six-digits

### Keys/Buttons:

Change, unit, zero, tare buttons  
Nine PLU keys

### Temperature Range:

Certified: 14 °F to 104 °F (-10 °C to 40 °C)

### Warranty:

One-year limited

### Approvals:

NTEP 04-067

## Approvals



## Part Number/Price

Part #	Model	Capacity	Est. Weight	Price
167941	RS-130 Bench	30 × 0.01 lb 15 × 0.005 kg 480 × 0.2 oz	12 lb	\$396.00
168100	RS-130 Pole	30 × 0.01 lb 15 × 0.005 kg 480 × 0.2 oz	13 lb	\$407.00
167942	RS-160 Bench	60 × 0.02 lb 30 × 0.01 kg 960 × 0.5 oz	12 lb	\$406.00
168101	RS-160 Pole	60 × 0.02 lb 30 × 0.01 kg 960 × 0.5 oz	13 lb	\$419.00

NOTE: Buy quantity of 5 and get a 50% discount

## Options/Accessories

Part #	Description	Price
169634	Additional operating manual	\$15.00
169635	Additional calibration instructions	\$5.00
85711	Additional in-use cover	\$7.00
47976	Fish platter, (W × D) 9.5 × 13.5 in	\$108.00
47977	Produce platter, (W × D) 9.5 × 13.5 in	\$85.00
85710	Replacement rechargeable battery, 6 V	\$25.00

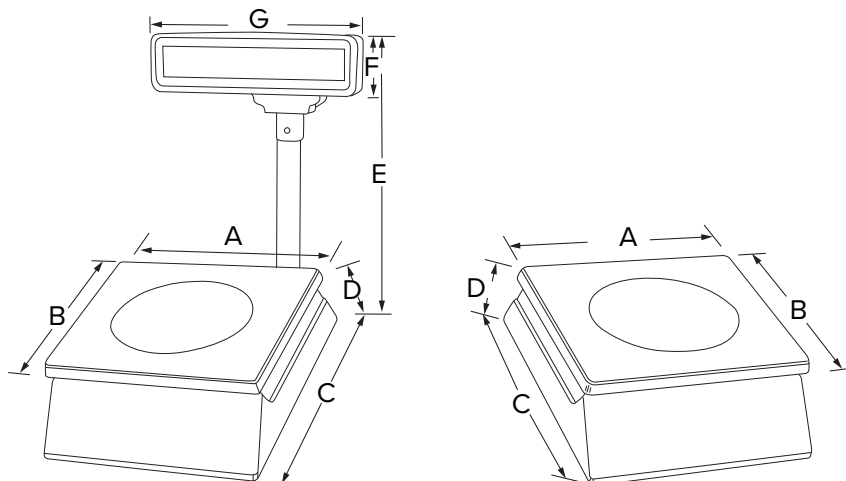

## Dimensions

Bench			
Unit			
A	300 mm	C	330 mm
B	240 mm	D	120 mm
Pole			
Unit			
A	300 mm	E	410 mm
B	240 mm	F	78 mm
C	330 mm	G	280 mm
D	120 mm		

RETAIL SCALES

# Ishida Astra II

Price Computing Scale with Printer



## Approvals



## Part Number/Price

Part #	Model	Capacity	Est. Weight	Price
185822	Astra II Bench	30 × 0.01 lb	25 lb	\$1,919.00
185823	Astra II Pole	30 × 0.01 lb	25 lb	\$2,016.00
190641	Astra II Lite software CD (available for download at <a href="http://www.ricelake.com">www.ricelake.com</a> )			N/C
190642	Astra II Lite license file (for one computer only, not transferable)			\$154.00

## Options/Accessories

Part #	Description	Price
47977	Produce platter (sits on top platter included with scale)	\$85.00
47976	Fish platter (sits on top platter included with scale)	\$108.00
47341	Continuous roll thermal journal paper, 64 mm W × 50 m L (for reports only)	\$6.00
184273*	Technical manual	\$15.00
184270*	Additional operating manual	\$15.00
184274*	Additional operation card	\$15.00
170916	Additional operator keysheet insert	\$28.00
<b>Label Stock</b>		
47732	2.36 × 1.73 in (60 × 44 mm)	\$96.00
47733	2.52 × 1.85 in (64 × 47 mm)	\$96.00
47735	2.52 × 2.32 (64 × 59 mm)	\$96.00
47736	Pre-printed safe handling instructions, 2.52 × 2.32 in (64 × 59 mm)	\$96.00
47743***	Extended text, 2.52 × 3.34 in (64 × 85 mm)	\$96.00
47745	Pre-printed safe handling instructions on top of label, 2.52 × 3.34 in (64 × 85 mm)	\$96.00
47753	Blank 2.52 × 1.46 in (64 × 37 mm)	\$96.00
47754	Blank 2.52 × 1.85 in (64 × 47 mm)	\$99.00
47761	Continuous strip label stock 2.25 × 121 in (64 × 37,000 mm)	\$96.00
47762	Non-bar code, 2.52 × 2.32 in (64 × 37 mm)	\$96.00
105346	Blank 2.52 × 3.34 in (64 × 85 mm)	\$96.00

Label stock, please consult factory for case quantity pricing. Examples shown on page 911  
Labels sold by the case-12 rolls per case.

\* Manuals and software programs can be downloaded at [www.ricelake.com](http://www.ricelake.com)  
\*\*\* Safe handling instructions can also be printed by scale

## Standard Features

- Programmable function keys
- Blue alphanumeric LCD display
- Convenient side-loading label feature
- Wired Ethernet
- Customer display

## Specifications

### Power:

AC 100 to 240 V, 50/60 Hz

### Power Consumption:

Standby: 50 W  
In operation: 100 W

### Resolution:

Display: 3,000 divisions

### Communication Ports:

Ethernet: TCP/IP 10/100 Base-T  
USB: data backup and restore

### Memory Capacity:

2 MB

### Annunciators:

Net, zero, save, auto

### Display:

Blue alphanumeric LCD display (23 digits, 16 segments)

### Display Items:

Tare: four-digits  
Unit price: five-digits  
Total price: six-digits

### Keys/Buttons:

84 one-touch preset keys, 168 presets (assign two items/key)

### Printing Speed:

3.9 in (100 mm) per second

### Printing:

Direct thermal 2.2 in (56 mm) (448 dot, 8 dot/mm)

### Label Size:

Width: 1.5 to 2.5 in (38 to 64 mm)  
Length: 1.2 to 6.9 in (30 to 175 mm)

### Label Roll:

Inside diameter: 1.6 in (40 mm)  
Outside diameter: 3.9 in (100 mm)

### Label Backing Paper:

Width: Up to 2.6 in (66 mm)

### Temperature :

Certified: 14 °F to 104 °F (-10 °C to 40 °C)

### Warranty:

One-year limited

### Approvals:

NTEP 07-005  
UL

# Ishida Astra II

Price Computing Scale with Printer

## Dimensions

Astra II			
Bench Unit			
A	17.2 in (437 mm)	F	6.3 in (160 mm)
B	10.5 in (266 mm)	G	14.6 in (370 mm)
C	16.1 in (410 mm)		

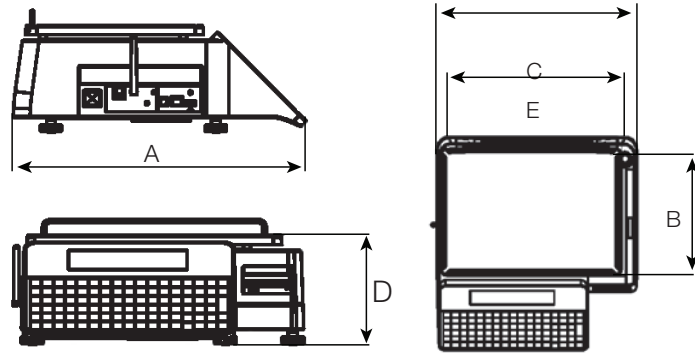

Astra II			
Pole Unit			
A	17.2 in (437 mm)	E	20.6 in (524 mm)
B	10.5 in (266 mm)	F	6.3 in (160 mm)
C	16.1 in (410 mm)	G	14.6 in (370 mm)
D	19.7 in (500 mm)		

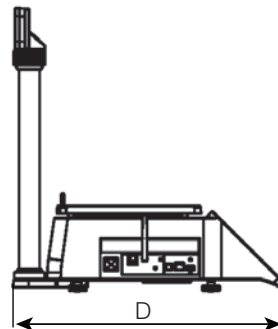
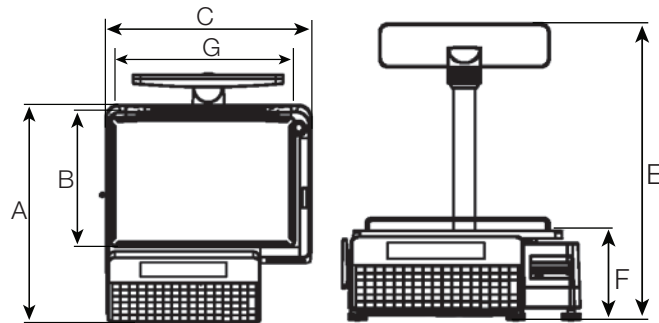

RETAIL SCALES

Titles on labels are pre-printed (SELL BY, PACKED ON, \$ LB, NET WT, TOTAL PRICE)

Maximum description text per label:

Formats 1-5..... 1 name line + 2 ingredient lines

Format 6..... 1 name line + 6 ingredient lines

Format 7..... 1 name line + 17 ingredient lines

Format 8..... 1 name line + 6 ingredient lines

### Format 1

SELL BY	PACKED ON	\$/LB.	WEIGHT(LB.)
			<b>TOTAL PRICE(\$)</b>

#### Example PN 47732

**60 x 44 STD.**  
Part #47732 800 Labels Per Roll

SELL BY	PACKED ON	\$/LB.	WEIGHT(LB.)
SEP28.15	SEP27.15	0.00	0.71

0 200000 200003 1000

**TOTAL PRICE(\$)**  
**\$0.00**

RICE LAKE/ISHIDA  
230 W. Coleman St. Rice Lake, WI (800) 472-6703

### Format 5

PACKED ON	\$/LB.	NET WT.	TOTAL PRICE
SELL BY			
			<b>TOTAL PRICE</b>

#### Example PN 47762

**60 x 37 NON BAR CODE**  
Part #47762 1000 Labels Per Roll

PACKED ON	\$/LB.	NET WT.	TOTAL PRICE
SEP27.15	0.00	0.71	

SELL BY  
SEP28.15

**TOTAL PRICE**  
**\$0.00**

RICE LAKE/ISHIDA  
230 W. Coleman St. Rice Lake, WI (800) 472-6703

### Format 2

SELL BY	PACKED ON	\$/LB.	NET WT.
			<b>TOTAL PRICE</b>

#### Example PN 47733

**64 x 47 STD.**  
Part #47733 800 Labels Per Roll

SELL BY	PACKED ON	\$/LB.	NET WT.
SEP28.15	SEP27.15	0.00	0.71

0 200000 200003 1000

**TOTAL PRICE**  
**\$0.00**

RICE LAKE/ISHIDA  
230 W. Coleman St. Rice Lake, WI (800) 472-6703

### Format 6

SELL BY	PACKED ON	\$/LB.	NET WT.
			<b>TOTAL PRICE</b>

#### Example PN 47735

**64 x 59 EXTENDED TEXT**  
Part #47735 625 Labels Per Roll

SELL BY	PACKED ON	\$/LB.	NET WT.
SEP28.15	SEP27.15	5.99	0.14

**TOTAL PRICE**  
**\$0.84**

RICE LAKE/ISHIDA  
230 W. Coleman St. Rice Lake, WI (800) 472-6703

### Format 3

SELL BY	PACKED ON	\$/LB.	NET WT. (LB.)
			<b>TOTAL PRICE \$</b>

#### Example PN 47743

**64 x 85 SAFE HANDLING**  
Part #47743 425 Labels Per Roll

**SAFE HANDLING INSTRUCTIONS**  
THIS PRODUCT WAS PREPARED FROM INSPECTED AND PASSED MEAT AND/OR POULTRY. SOME FOOD PRODUCTS MAY CONTAIN BACTERIA THAT COULD CAUSE ILLNESS IF THE PRODUCT IS MISHANDLED OR COOKED IMPROPERLY. FOR YOUR PROTECTION, FOLLOW THESE SAFE HANDLING INSTRUCTIONS:

- KEEP REFRIGERATED OR FROZEN, THAW IN REFRIGERATOR OR MICROWAVE.
- KEEP RAW MEAT AND POULTRY SEPARATE FROM OTHER FOODS. WASH WORKING SURFACES (INCLUDING CUTTING BOARDS, UTENSILS, AND HANDS) IMMEDIATELY OR DISCARD.
- COOK THOROUGHLY.
- KEEP HOT FOODS HOT. REFRIGERATE LEFTOVERS IMMEDIATELY OR DISCARD.

SELL BY	PACKED ON	\$/LB.	NET WT. (LB.)
SEP28.15	SEP27.15	0.00	0.71

0 200000 200003 1000

**TOTAL PRICE \$**  
**\$0.00**

RICE LAKE/ISHIDA  
230 W. Coleman St. Rice Lake, WI (800) 472-6703

### Format 7

SELL BY	PACKED ON	\$/LB.	NET WT. (LB.)
			<b>TOTAL PRICE \$</b>

#### Example PN 47743

**64 x 85 EXTENDED TEXT**  
Part #47743 425 Labels Per Roll

SELL BY	PACKED ON	\$/LB.	NET WT. (LB.)
SEP28.23	SEP27.23	0.49	0.71

0 200000 200353 1000

**TOTAL PRICE \$**  
**\$0.35**

RICE LAKE/ISHIDA  
230 W. Coleman St. Rice Lake, WI (800) 472-6703

### Format 4

**SAFE HANDLING INSTRUCTIONS**  
THIS PRODUCT WAS PREPARED FROM INSPECTED AND PASSED MEAT AND/OR POULTRY. SOME FOOD PRODUCTS MAY CONTAIN BACTERIA THAT COULD CAUSE ILLNESS IF THE PRODUCT IS MISHANDLED OR COOKED IMPROPERLY. FOR YOUR PROTECTION, FOLLOW THESE SAFE HANDLING INSTRUCTIONS:

- KEEP REFRIGERATED OR FROZEN, THAW IN REFRIGERATOR OR MICROWAVE.
- KEEP RAW MEAT AND POULTRY SEPARATE FROM OTHER FOODS. WASH WORKING SURFACES (INCLUDING CUTTING BOARDS, UTENSILS, AND HANDS) IMMEDIATELY OR DISCARD.
- COOK THOROUGHLY.
- KEEP HOT FOODS HOT. REFRIGERATE LEFTOVERS IMMEDIATELY OR DISCARD.

NET WT (LBS)	PRICE/LB (\$)	DATE

**TOTAL PRICE**

#### Example PN 47736

**64 x 59 SAFE HANDLING**  
Part #47736 625 Labels Per Roll

**SAFE HANDLING INSTRUCTIONS**  
THIS PRODUCT WAS PREPARED FROM INSPECTED AND PASSED MEAT AND/OR POULTRY. SOME FOOD PRODUCTS MAY CONTAIN BACTERIA THAT COULD CAUSE ILLNESS IF THE PRODUCT IS MISHANDLED OR COOKED IMPROPERLY. FOR YOUR PROTECTION, FOLLOW THESE SAFE HANDLING INSTRUCTIONS:

- KEEP REFRIGERATED OR FROZEN, THAW IN REFRIGERATOR OR MICROWAVE.
- KEEP RAW MEAT AND POULTRY SEPARATE FROM OTHER FOODS. WASH WORKING SURFACES (INCLUDING CUTTING BOARDS, UTENSILS, AND HANDS) IMMEDIATELY OR DISCARD.
- COOK THOROUGHLY.
- KEEP HOT FOODS HOT. REFRIGERATE LEFTOVERS IMMEDIATELY OR DISCARD.

NET WT (LBS)	PRICE/LB (\$)	DATE
0.71	0.00	SEP27.15 SEP28.15

0 200000 200003 1000

**TOTAL PRICE**  
**\$0.00**

RICE LAKE/ISHIDA  
230 W. Coleman St. Rice Lake, WI (800) 472-6703

### Format 8

**SAFE HANDLING INSTRUCTIONS**  
THIS PRODUCT WAS PREPARED FROM INSPECTED AND PASSED MEAT AND/OR POULTRY. SOME FOOD PRODUCTS MAY CONTAIN BACTERIA THAT COULD CAUSE ILLNESS IF THE PRODUCT IS MISHANDLED OR COOKED IMPROPERLY. FOR YOUR PROTECTION, FOLLOW THESE SAFE HANDLING INSTRUCTIONS:

- KEEP REFRIGERATED OR FROZEN, THAW IN REFRIGERATOR OR MICROWAVE.
- KEEP RAW MEAT AND POULTRY SEPARATE FROM OTHER FOODS. WASH WORKING SURFACES (INCLUDING CUTTING BOARDS, UTENSILS, AND HANDS) IMMEDIATELY OR DISCARD.
- COOK THOROUGHLY.
- KEEP HOT FOODS HOT. REFRIGERATE LEFTOVERS IMMEDIATELY OR DISCARD.

SELL BY	PACKED ON	\$/LB.	NET WT.
			<b>TOTAL PRICE</b>

#### Example PN 47745

**64 x 85 REDUCED S.H.**  
Part #47745 425 Labels Per Roll

**SAFE HANDLING INSTRUCTIONS**  
THIS PRODUCT WAS PREPARED FROM INSPECTED AND PASSED MEAT AND/OR POULTRY. SOME FOOD PRODUCTS MAY CONTAIN BACTERIA THAT COULD CAUSE ILLNESS IF THE PRODUCT IS MISHANDLED OR COOKED IMPROPERLY. FOR YOUR PROTECTION, FOLLOW THESE SAFE HANDLING INSTRUCTIONS:

- KEEP REFRIGERATED OR FROZEN, THAW IN REFRIGERATOR OR MICROWAVE.
- KEEP RAW MEAT AND POULTRY SEPARATE FROM OTHER FOODS. WASH WORKING SURFACES (INCLUDING CUTTING BOARDS, UTENSILS, AND HANDS) IMMEDIATELY OR DISCARD.
- COOK THOROUGHLY.
- KEEP HOT FOODS HOT. REFRIGERATE LEFTOVERS IMMEDIATELY OR DISCARD.

SELL BY	PACKED ON	\$/LB.	NET WT.
SEP28.15	SEP27.15	3.30	0.72

0 200000 202383 1000

**TOTAL PRICE**  
**\$2.38**

RICE LAKE/ISHIDA  
230 W. Coleman St. Rice Lake, WI (800) 472-6703

RETAIL SCALES

# Rice Lake BenchPro™ BP-R

Retail Digital Bench Scale



BP-R 10 × 10 in with optional tabletop display pole PN 183103 and customer display PN 180901

## Approvals



Measurement  
Canada  
Approved



## Part Number/Price

Part #	Capacity	Dimensions	Est. Weight	Price
182374	15 × 0.005 lb (6 × 0.002 kg) / 15 lb × 0.1 oz	6 × 10 in	12 lb	\$825.00
182375	30 × 0.01 lb (15 × 0.005 kg) / 30 lb × 0.2 oz	6 × 10 in	12 lb	\$825.00
182376	15 × 0.005 lb (6 × 0.002 kg) / 15 lb × 0.1 oz	10 × 10 in	15 lb	\$825.00
182377	30 × 0.01 lb (15 × 0.005 kg) / 30 lb × 0.2 oz	10 × 10 in	15 lb	\$825.00
179733	15 × 0.005 lb (6 × 0.002 kg) / 15 lb × 0.1 oz	12 × 14 in	17 lb	\$665.00
179732	30 × 0.01 lb (15 × 0.005 kg) / 30 lb × 0.2 oz	12 × 14 in	17 lb	\$665.00

## Options/Accessories

Part #	Description	Est. Weight	Price
174783	Column bracket and post (12 × 14 in scale only)	2 lb	\$50.00
180901	Second customer display, BenchPro BP-R no keyboard with 68 in cable	4 lb	\$72.00
174784	Second remote operator display, BenchPro BP-R with 68 in cable	4 lb	\$88.00
183103	16 in (H) tabletop display post for use with second display, customer or remote operator	4 lb	\$215.00
178501	USB-RS-232 serial adapter	1 lb	\$60.00
196179	Wedgelink cable for direct RS-232 output, 9600-N-8-1	1 lb	\$255.00

## Standard Features

- Large LCD display protected by heavy-duty tempered glass
- Powered USB HID point of sale interface—plug and play USB interface provides power and communications
- Interface for use with SMA, NCI and ECR
- Battery operation for portability (BP-R 12 × 14 in scale only)
- Gravitational compensation allows for adjustment of factory calibration to meet your local gravity setting, non-approved

## Specifications

### Power:

100 to 240 VAC, 50/60 Hz ± 3 Hz  
12 × 14 in scale only:  
AA alkaline batteries (not included)

### Battery Life:

250 hrs sleep mode or 80 hrs continuous use, backlight on 80 hrs sleep mode or 50 hrs continuous use

### Screen Resolution:

0 to 1,000 d, 1.0 sec, maximum average  
1,000 d +, 1.5 sec, maximum average

### Communication Ports:

RS-232 DB 9-pin male to female, straight pass through and null modem (10 ft cable included)  
USB A/B type (46 in cable included)  
USB HID, 2.0 full speed, vendor ID 1C19, product ID 0002

### Display:

Six-digit backlight LCD display with 1 in (25 mm) characters protected by heavy-duty tempered glass

### Platter:

Stainless steel

### Keys/Buttons:

Zero, units, tare, F1

### Temperature:

Certified: 14 °F to 104 °F (-10 °C to 40 °C)

### Warranty:

One-year limited

### Approvals:

NTEP 17-002  
Measurement Canada AM-6050  
CE



Operator display



Customer display  
(optional)

## Dimensions

	A	B	C	D
6 × 10 in	6.0 in	10.0 in	9.0 in	2.4 in
10 × 10 in	10.0 in	10.0 in	13.0 in	2.5 in
12 × 14 in	12.0 in	14.0 in	14.5 in	2.7 in

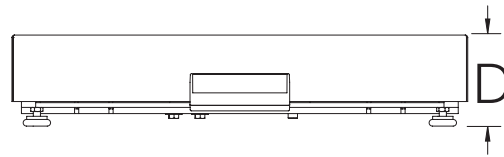
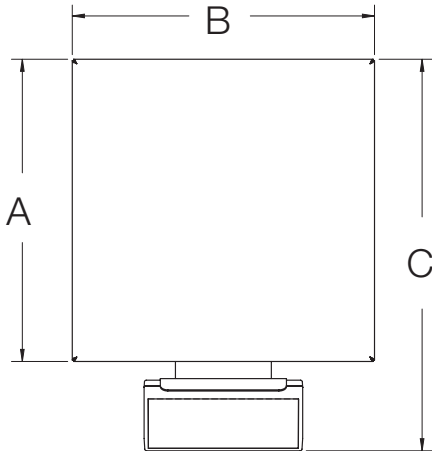

BP-R 12 × 14 scale



BP-R 06 × 10 scale



BP-R 12 × 14 scale with optional column bracket & post

# QuikSharp™

Sharpener



## Standard Features

- Tungsten carbide blades
- Ceramic honing rods
- Reversible blades

## Specifications

### Dimensions:

(L × W × H)  
6.00 × 0.75 × 2.50 in  
(152 × 19 × 64 mm)

## Part Number/Price

Part #	Description	Weight	Price
78720	Intruder QuikSharp™ complete knife sharpening system	2.25 oz	\$14.00

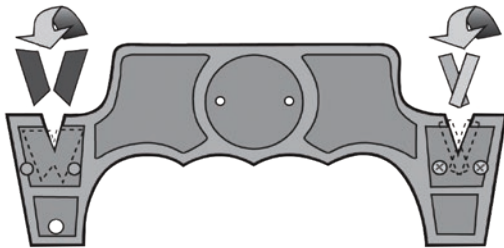

## HOW TO REVERSE CARBIDE BLADES AND CERAMIC RODS

### 1. Remove screws to open sharpener.

### 2. Reverse blades or rods as shown.

### 3. Replace screws and reassemble sharpener.

Reversible blades have a total expected life of four to five years with normal use.

# Weight Set

ASTM Class 5 Stainless Steel Satin 30 lb kit



## Standard Features

- ASTM Class 5
- Protective case
- Stainless steel

## Weight Sets

Part #	Description	Optional Accredited Certificate	Price
12640	30 lb weight kit (5 lb - 6 pcs) satin	\$470.00	\$1,130.00
12638	30 lb weight kit (10 lb - 3 pcs) satin	\$235.00	\$975.00

RETAIL SCALES