

# Ready-n-Weigh Bench Scale System

CW-90B Bench Scale and 680 Indicator Package

BENCH SCALES



Scale and Indicator Package

## Approvals



Measurement Canada Approved



## CW-90B with 680 Package

Part #	Platform Capacity	Dimensions (L × W × H)	Est. Weight	Price
<b>115-230 VAC, LED, Numeric, US Plug-Type B</b>				
201308	5 lb (2.5 kg)	10 × 10 × 4.25 in	24 lb	Consult
201309	10 lb (5 kg)	10 × 10 × 4.25 in	24 lb	Consult
201310	25 lb (10 kg)	10 × 10 × 4.25 in	24 lb	Consult
201311	25 lb (10 kg)	12 × 12 × 4.25 in	27 lb	Consult
201312	50 lb (25 kg)	12 × 12 × 4.25 in	27 lb	Consult
201313	100 lb (50 kg)	12 × 12 × 4.25 in	27 lb	Consult
<b>115-230 VAC, LED, Numeric, Euro Plug-Type E</b>				
201314	5 lb (2.5 kg)	10 × 10 × 4.25 in	24 lb	Consult
201315	10 lb (5 kg)	10 × 10 × 4.25 in	24 lb	Consult
201319	25 lb (10 kg)	10 × 10 × 4.25 in	24 lb	Consult
201320	25 lb (10 kg)	12 × 12 × 4.25 in	27 lb	Consult
201321	50 lb (25 kg)	12 × 12 × 4.25 in	27 lb	Consult
201322	100 lb (50 kg)	12 × 12 × 4.25 in	27 lb	Consult



\* US plug (NA) - Type B



\*\* Euro Plug - Type E

## Dimensions

CW-90B Bench Scale and 680 Indicator			
10 × 10 in			
A	19.56 in	E	9.31 in
B	10.25 in	F	4.25 in
C	15.83 in	G	10.25 in
D	13.31 in		

Note: 1 in = 25.4 mm

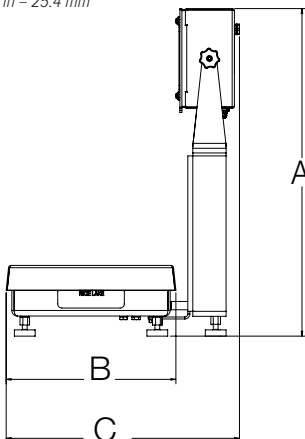

12 × 12 in			
A	19.56 in	E	9.31 in
B	12.25 in	F	4.25 in
C	16.83 in	G	12.25 in
D	13.31 in		

Note: 1 in = 25.4 mm

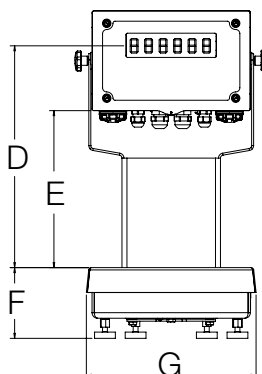

## Standard Features

- Package includes scale, NTEP Certified load cell, indicator and 12-inch column
- Factory calibrated with indicator setup and configured for 5,000 divisions
- Scale includes rubber feet to provide exceptional traction and avoid scratching surfaces along with removable top cover for ease of cleaning
- Battery backed time and date
- Standard RS-232 serial ports for connecting to a variety of peripheral

## CW-90B Specifications

### Load Cell:

IP67, environmentally sealed  
Aluminum

### Scale Construction:

304 stainless steel

### Maximum Overload:

180% to 200% depending on capacity

### Overload Protection:

Five-point, independently adjusted

### Scale Frame:

AISI304L, straight line finish, Ra=45 ± 10

### Scale Cover:

AISI304L, straight line finish, Ra=45 ± 10

### Cable Length:

34 in (86 cm)

### Temperature:

Compensated:  
14 °F to 104 °F (-10 °C to 40 °C)

### Warranty:

Two-year limited

### Approvals:

NTEP 95-072, Class III 5,000 d  
Measurement Canada AM-5082  
NSF  
Load cell is NTEP  
Load cell is cFMus Approved

## 680 Specifications

### Power:

Line voltage: 100 to 240 VAC  
Frequency: 50/60 Hz

### Communication Ports:

Two full-duplex RS-232  
RS-485/422 (five-wire)  
Micro USB (device)  
Ethernet TCP/IP (10/100)

### Display:

Seven 0.8 in (20 mm) tall, seven-segment digits

### Annunciators:

Eight LED annunciators

### Keys/Buttons:

Flat membrane panel, tactile feel  
(18 buttons plus ON/OFF)

### Rating/Material:

IP69K (IP66 with RJ45)  
AISI 304 stainless Steel

### Warranty:

Two-year limited

### Approvals:

NTEP 19-021  
Measurement Canada AM-6121C  
CE Marked  
cULus Listed