

# 65040A-1127W

Alloy Steel, Welded Seal, NTEP Certified 1:10,000 Class IIII Multiple Cell, IP67



Picture is a representation of actual product

### Approvals



### Order Information

Load Rating	Part#	Est. Weight	Price
50,000 lb	66080	18 lb	Consult
65,000 lb	87162	20 lb	Consult

### Dimensions

Rated Capacity	A	B	D	E	F	G	H	J	K	L	M	N	P	Q	R
50,000 to 65,000 lb/in	10.25	5.12	1.00	0.75	0.78	2.40	4.25	8.50	1.00	2.06	1/2-14 NPT	1.50	3.00	1.03	2.20

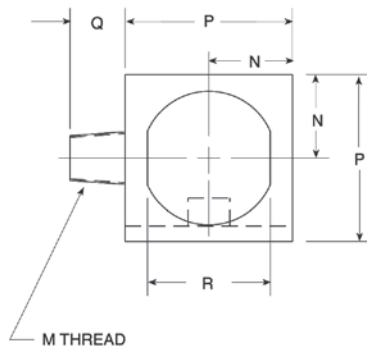
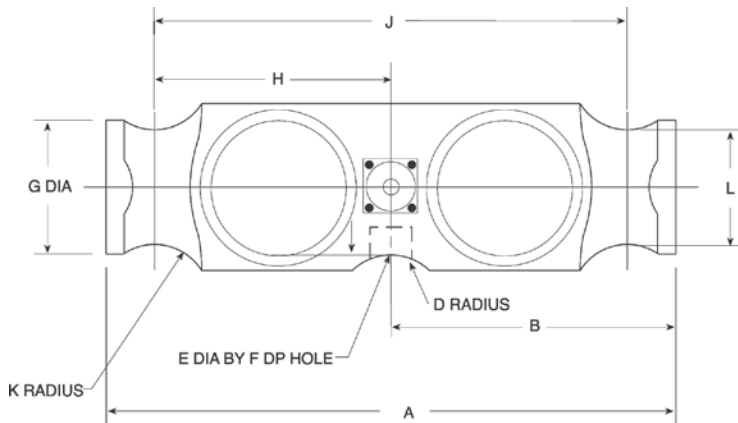

### Interchangeable Products

- RICE LAKE WEIGHING SYSTEMS  
**RL75223** .....page 140
- VPG® REVERE  
**5223** .....page 257
- ARTECH®  
**80210**
- THURMAN®  
**TSC 800**

### Weigh Module Available

- RICE LAKE WEIGHING SYSTEMS  
**Translink™** .....page 73

### Specifications

- Full Scale Output:**  
3.0 mV/V
- Output Resistance:**  
699 to 707 ohm
- Input Resistance:**  
686 to 714 ohm
- Material/Finish:**  
High-alloy steel
- Temperature:**  
Compensated:  
14 °F to 104 °F (-10 °C to 40 °C)  
Operating:  
0 °F to 150 °F (-18 °C to 65 °C)
- Seal Type:**  
Welded-seal, IP67
- Safe Overload:**  
150% full scale
- Safe Sideload:**  
100% full scale
- Rated Excitation:**  
5 to 10 V DC (15 V maximum)
- Combined Error:**  
0.03% full scale
- Non-repeatability:**  
0.01% full scale
- Insulation Resistance:**  
1,000 megohm
- Deflection at Capacity:**  
50,000 lb: 0.018 in  
65,000 lb: 0.022 in
- Cable Length:**  
40 ft
- Cable Diameter:**  
0.305 in  
Polyurethane jacket
- Cable Color Code:**  
Red +Excitation  
Black -Excitation  
Green +Signal  
White -Signal
- Warranty:**  
One-year limited
- Approvals:**  
NTEP  
cFMus