

SINGLE-ENDED BEAMS

Page 224 **H35, STAINLESS STEEL**



Offers all stainless steel construction, an integral mounting foot, and dimensional and electrical interchangeability with several load cell manufacturers. Capacities range from 500 lb to 5,000 lb. Each cell comes with 20 ft of load cell cable.



Page 225 **BBS, ALLOY STEEL**



Low-cost bending beam load cell designed for precision force and weight measurement. Features excellent performance and protection against adverse environments, alloy and stainless steel sensing elements, and low mounting sensitivity. Capacities range from 50 lb to 7,500 lb. Complete with 10 ft of load cell cable.



Page 226 **Z6, STAINLESS STEEL**



Featuring stainless steel and a welded seal, this bending beam load cell is ideal for harsh or caustic environments and washdown applications. Capacities range from 5 to 200 kg. Complete with 10 ft of load cell cable.



ROCKER COLUMN

Page 227 **C16A, STAINLESS STEEL**



A rocker column load cell specifically designed for high-capacity weighing in the harshest environments. Ideal for truck scale applications, it features all stainless steel construction with IP68 hermetic sealing. Easy to install and maintain. Available in capacities ranging from 20 t to 60 t and includes 12 m of load cell cable.



SINGLE POINTS

Page 228 **SP4M, ALUMINUM**



A low-profile, off-center load cell designed for use in retail, postal and platform scale applications. Manufactured from aluminum, the SP4M is movement compensated for guaranteed accuracy. Protected by a quality gauge coating compound that provides a barrier against high humidity environments. Capacities range from 3 to 100 kg, and comes standard with 10 ft of load cell cable.



Page 229 **PW15, STAINLESS STEEL**



A stainless steel, single point load cell with capacities ranging from 15 to 150 kg. Ideal for platform, hanging scale and other low capacity beam applications. Complete with 10 ft of load cell cable.



Page 230 **PW15AH, STAINLESS STEEL**



The new standard for hermetically sealed, single-point load cells. A unique sealing process guarantees moisture protection from high-pressure jets. IP69K rated and available in 10, 20, 50 and 100 kg capacities.



Page 231 **PWS, STAINLESS STEEL**



A single-point cell, constructed of stainless steel and designed for performance in harsh, high-shock load environments. These features make the PWS ideal for platform scales and packaging and process weighing equipment. Capacities range from 7 to 150 kg. Complete with 10 ft of load cell cable.



H35

Stainless Steel, Welded Seal, NTEP Certified 1:5,000 Class III Multiple Cell, IP67



Picture is a representation of actual product.

Approvals



Order Information

Load Rating	Part #	Est. Weight	Price
500 lb	84818	3 lb	\$371.00
1,000 lb	64876	3 lb	\$371.00
2,500 lb	64877	3 lb	\$371.00
4,000 lb	64878	3 lb	\$371.00
5,000 lb	64879	3 lb	\$371.00

Dimensions

Rated Capacity	A1	A2	A3	A4	B	C	D	E	F	G	H	I
500 to 5,000	1/2-20 UNF-2B	0.62	0.53	0.53	1.21	1.19	5.12	1.00	3.00	0.50	2.85	1.12

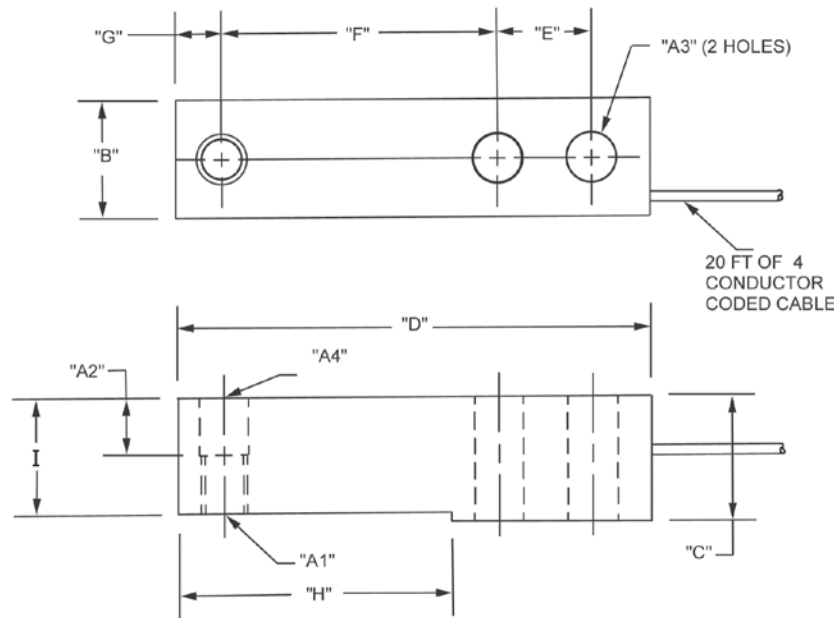

Interchangeable Products

RICE LAKE WEIGHING SYSTEMS	
RLH35	page 110
METTLER TOLEDO®	
500 lb-8 ft cable.....	TB601019-008
1,000 lb-20 ft cable	TB601016-020
2,500 lb-8 ft cable.....	TB601016-008
4,000 lb-20 ft cable.....	TB601017-020
5,000 lb-8 ft cable	TB601018-008
METTLER TOLEDO	
500 lb.....	TB600830-020
METTLER TOLEDO	
1,000 lb.....	TB600831-020
METTLER TOLEDO	
2,000 lb	TB600832-020
METTLER TOLEDO	
2,500 lb.....	TB600833-020

Specifications

- Full Scale Output:**
3.0 mV/V
- Output Resistance:**
350 (± 3) ohm
- Input Resistance:**
385 ohm nominal
- Material/Finish:**
Stainless steel
- Temperature:**
Compensated range
14 °F to 104 °F (-10 °C to 40 °C)
Operating range
0 °F to 150 °F (-18 °C to 65 °C)
- Seal Type:**
Welded-seal, IP67
- Safe Overload:**
150% full scale
- Safe Sideload:**
100% full scale
- Rated Excitation:**
5 to 10 V DC (15 V maximum)
- Combined Error:**
0.02% full scale
- Insulation Resistance:**
5,000 megohm
- Cable Length:**
20 ft
- Cable Diameter:**
0.190 in
Polyurethane jacket
- Cable Color Code:**
Green +Excitation
Black -Excitation
White +Signal
Red -Signal
Yellow Shield
- Warranty:**
One-year limited
- Approvals:**
FM
NTEP

HBK



Picture is a representation of actual product.

Approvals



Order Information

Load Rating	Part #	Est. Weight	Price
50 lb	17352	3 lb	\$927.50
100 lb	17353	3 lb	\$927.50
200 lb	17354	3 lb	\$927.50
250 lb	17355	3 lb	\$927.50
500 lb	17356	3 lb	\$927.50
1,000 lb	17357	3 lb	\$927.50

Dimensions

Rated Capacity	A	A1	A2	B	C	D	E	F	G	H
lb/in										
50 to 100	6.00	0.31	0.31	0.38	0.88	4.25	1.06	1.25	—	—
200 to 1,000	6.63	0.51	0.51	0.50	1.12	4.25	1.06	1.25	—	—

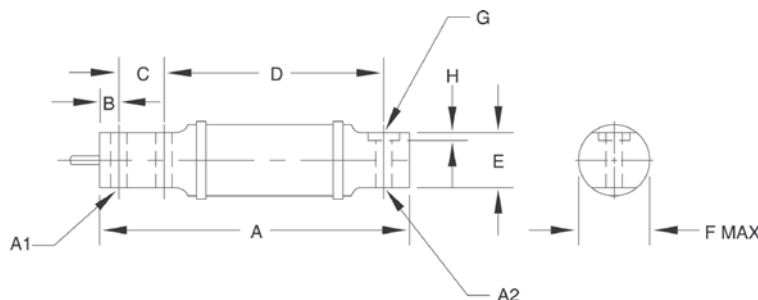

Interchangeable Products

RICE LAKE WEIGHING SYSTEMS

RL40BBSpage 121

VPG® SENSORTRONICS

60007

VPG® BLH

LBG1

FAIRBANKS®

3-481XX-1, 3-486XX-1

Specifications

Full Scale Output:

2.0 mV/V

Output Resistance:

750 (± 15) ohm

Input Resistance:

375 (± 10) ohm

Material/Finish:

High-alloy steel, nickel plated

Temperature:

Operating range
0 °F to 150 °F (-18 °C to 65 °C)

Seal Type:

Environmentally sealed, IP65

Safe Overload:

150% full scale

Safe SideLoad:

50% full scale

Rated Excitation:

5 to 10 V DC (15 V maximum)

Nonlinearity:

0.03% full scale

Hysteresis:

0.03% full scale

Insulation Resistance:

1,000 megohm

Deflection at Capacity:

50 lb: 0.015 in
100 lb: 0.025 in
200 to 250 lb: 0.030 in
500 lb: 0.020 in
1,000 lb: 0.040 in

Cable Length:

10 ft

Cable Diameter:

0.190 in
Polyurethane jacket

Cable Color Code:

Green +Excitation
Black -Excitation
White +Signal
Red -Signal
Yellow Shield

Warranty:

One-year limited

Approvals:

FM

Z6

Stainless Steel, Welded Seal, OIML C3, IP68

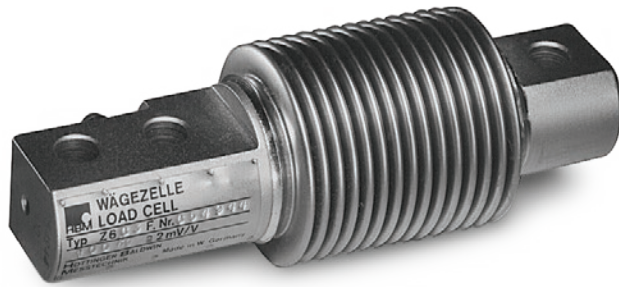

Picture is a representation of actual product.

Approvals



Order Information

Load Rating	Part #	Est. Weight	Price
OIML C3			
10 kg	36173	2 lb	\$689.00
20 kg	36174	2 lb	\$689.00
50 kg	36175	2 lb	\$689.00
100 kg	36176	2 lb	\$689.00
200 kg	36177	2 lb	\$689.00
OIML D1			
5 kg	36172	2 lb	\$689.00

Dimensions

Rated Capacity	H	L	L1	L2	L3	L4	L5	L6	W	W2	D
kg/mm											
5 to 200	31.0	123.0	18.0	82.0	9.9	21.0	45.0	27.9	42.0	20.1	8.2

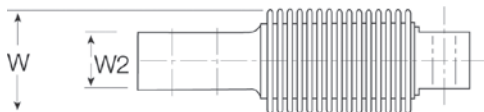
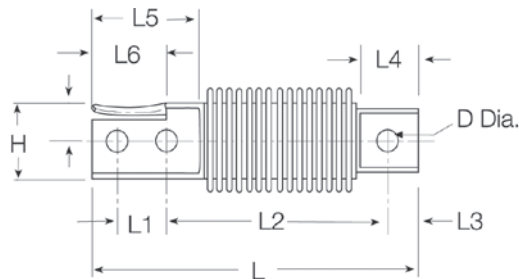

Interchangeable Products

- RICE LAKE WEIGHING SYSTEMS
RL9018SS page 107
- RICE LAKE WEIGHING SYSTEMS
RLHBB**
- VPG® REVERE
SHB page 253
- VPG® TEDEA-HUNTLEIGH
355 page 309
- METTLER TOLEDO®
MTB***

** Except for 500 kg

** Color code is different

Specifications

- Full Scale Output:**
2.0 mV/V
- Output Resistance:**
356 ohm
- Input Resistance:**
350 to 400 ohm
- Material/Finish:**
Stainless steel
- Temperature:**
Operating range
0 °F to 150 °F (-18 °C to 65 °C)
- Seal Type:**
Welded-seal, IP68
- Safe Overload:**
150% full scale
- Rated Excitation:**
5 to 10 V DC (15 V maximum)
- Combined Error:**
0.05% full scale
- Insulation Resistance:**
5,000 megohm
- Cable Length:**
10 ft
- Cable Diameter:**
0.190 in PVC jacket
- Cable Color Code:**
Blue +Excitation
Black -Excitation
White +Signal
Red -Signal
Green +Sense
Grey -Sense
- Warranty:**
One-year limited
- Approvals:**
FM
OIML
Ex (available upon request)

Stainless Steel, Hermetically Sealed, NTEP Certified 1:10,000 Class III Multiple Cell/OIML, IP68



Picture is a representation of actual product.

Approvals



Order Information

Load Rating	Part #	Est. Weight	Price
OIML C3			
20t	69312	6 lb	\$1,060.00
30t	69313	6 lb	\$1,060.00
40t	69314	10 lb	\$1,060.00
60t	125266	10 lb	\$1,113.00
NTEP Certified			
20t	106149	6 lb	\$1,060.00
30t	106150	6 lb	\$1,060.00
40t	106151	10 lb	\$1,060.00
60t	125265	10 lb	\$1,113.00

Dimensions

Rated Capacity	A	B	C	D	E	R
t/mm						
20	150.0	76.1	44.0	48.0	44.0	130.0
30	150.0	76.1	44.0	48.0	44.0	160.0
40	150.0	76.1	44.0	48.0	44.0	180.0
60	210.0	76.1	44.0	48.0	44.0	220.0

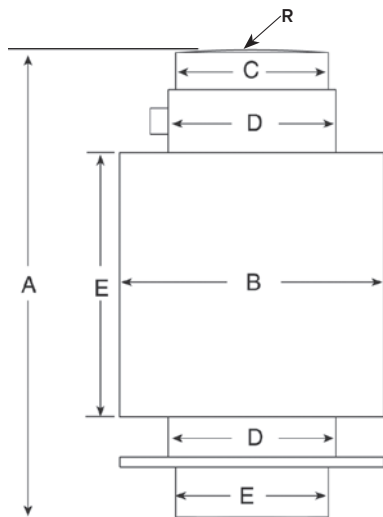

Specifications

Full Scale Output:2 mV/V \pm 1%**Output Resistance:**706 (\pm 3.5) ohm**Input Resistance:**700 (\pm 20) ohm**Material/Finish:**

Stainless steel

Temperature:

Compensated range

14 °F to 104 °F (-10 °C to 40 °C)

Operating range

0 °F to 150 °F (-18 °C to 65 °C)

Seal Type:

Hermetically sealed, IP68

Safe Overload:

130% full scale

Rated Excitation:

5 to 10 VDC (15 V maximum)

Combined Error:

0.03% full scale

Insulation Resistance:

5,000 megohm

Cable Length:

12 m

Cable Diameter:

0.190 in

Polyurethane jacket

Cable Color Code:

Blue +Excitation

Black -Excitation

White +Signal

Red -Signal

Green +Sense

Grey -Sense

Warranty:

One-year limited

Approvals:

NTEP

OIML



Picture is a representation of actual product.

Approvals



Order Information

Load Rating	Part #	Est. Weight	Price
NTEP Certified			
7 kg	72764	2 lb	\$238.50
15 kg	72767	2 lb	\$238.50
20 kg	72769	2 lb	\$238.50
30 kg	72771	2 lb	\$238.50
50 kg	72776	2 lb	\$238.50
75 kg	72777	2 lb	\$238.50
100 kg	72778	2 lb	\$238.50
OIML with Metric Threads			
3 kg	121396	2 lb	\$238.50
5 kg	121397	2 lb	\$238.50
7 kg	121398	2 lb	\$238.50
10 kg	121399	2 lb	\$238.50
15 kg	121400	2 lb	\$238.50
20 kg	121401	2 lb	\$238.50
30 kg	121402	2 lb	\$238.50
50 kg	121403	2 lb	\$238.50
75 kg	124835	2 lb	\$238.50
100 kg	121404	2 lb	\$238.50

Dimensions

Rated Capacity	A	B	C	D	E	F	G	H	I
kg/mm									
3 to 100	150.3	25.4	39.9	19.1	19.1	19.1	33.8	99.6	11.4

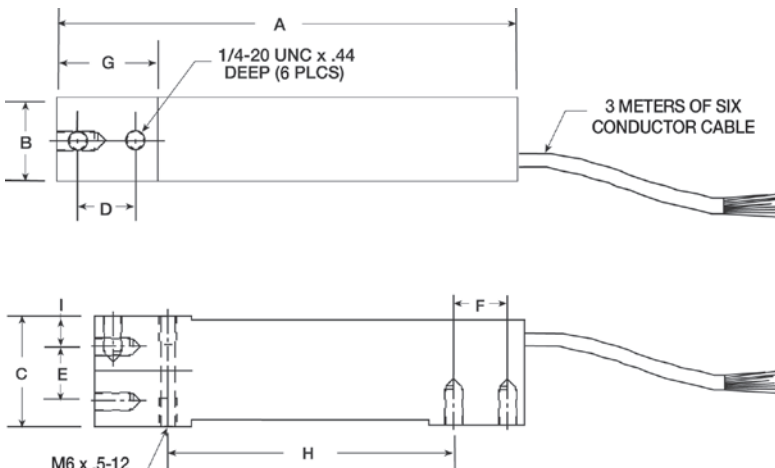

Interchangeable Products

- RICE LAKE WEIGHING SYSTEMS
RLSP4*.....page 158
- RICE LAKE WEIGHING SYSTEMS
RL1042.....page 161
- VPG® TEDEA-HUNTLEIGH
1042.....page 313

*Color code is different

Specifications

- Full Scale Output:**
2.0 mV/V
- Output Resistance:**
350 (± 3) ohm
- Input Resistance:**
350 ohm
- Material/Finish:**
Anodized Aluminum
- Temperature:**
Compensated range
14 °F to 104 °F (-10 °C to 40 °C)
Operating range
0 °F to 150 °F (-18 °C to 65 °C)
- Seal Type:**
Environmentally sealed, IP67
- Safe Overload:**
150% full scale
- Rated Excitation:**
5 to 10 VDC (15 V maximum)
- Combined Error:**
0.02% full scale
- Insulation Resistance:**
5,000 megohm
- Deflection at Capacity:**
0.015 in
- Cable Length:**
10 ft
- Cable Diameter:**
0.190 in PVC jacket
- Cable Color Code:**
Blue +Excitation
Black -Excitation
White +Signal
Red -Signal
Green +Sense
Grey -Sense
- Warranty:**
One-year limited

Approvals:

- FM
- NTEP
- OIML



Picture is a representation of actual product.

Approvals



Order Information

Load Rating	Part #	Est. Weight	Price
15 kg	76771	3 lb	\$387.00
20 kg	76772	3 lb	\$387.00
50 kg	76774	3 lb	\$387.00
75 kg	76775	3 lb	\$387.00
100 kg	76776	3 lb	\$387.00
150 kg	84820	3 lb	\$387.00

Dimensions

Rated Capacity	A	B	C	D	E	F	G	H	I	J	K	L	M
kg/mm													
15 to 150	35.0	13.0	40.0	13.0	13.0	35.0	75.0	150.0	19.0	100.0	19.0	6.2	25.0

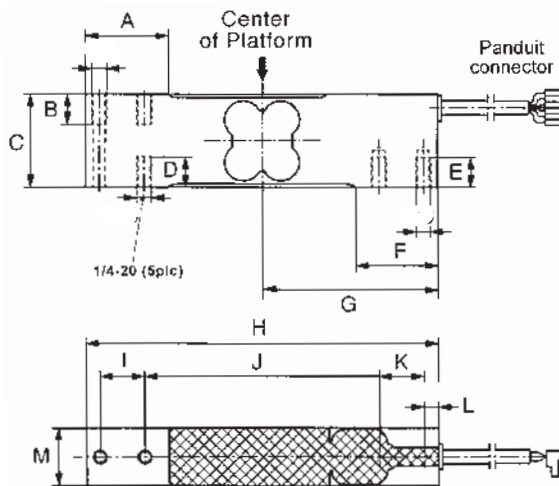

Interchangeable Products

- RICE LAKE WEIGHING SYSTEMS
- RLPWM15..... page 154
- VPG® TEDEA-HUNTLEIGH
- 1142* page 318

*Color code is different

Specifications

- Full Scale Output:** 2.0 mV/V
- Output Resistance:** 359 (± 5) ohm
- Input Resistance:** 380 (± 15) ohm
- Material/Finish:** Stainless steel
- Temperature:** Compensated range 14 °F to 104 °F (-10 °C to 40 °C)
Operating range 0 °F to 150 °F (-18 °C to 65 °C)
- Seal Type:** Environmentally sealed, IP67
- Safe Overload:** 150% full scale
- Rated Excitation:** 5 to 10 VDC (15 V maximum)
- Total Error:** 0.02% full scale
- Insulation Resistance:** 1,000 megohm
- Cable Length:** 10 ft
- Cable Diameter:** 0.190 in
PVC jacket
- Deflection:** 0.2 mm
- Cable Color Code:** Blue +Excitation
Black -Excitation
White +Signal
Red -Signal
Green +Sense
Grey -Sense
- Warranty:** One-year limited
- Approvals:** FM
NTEP



SINGLE POINT
PW15AH

Stainless Steel, Hermetically Sealed, NTEP Certified 1:5,000 Class III Single Cell, OIML C3, IP69K

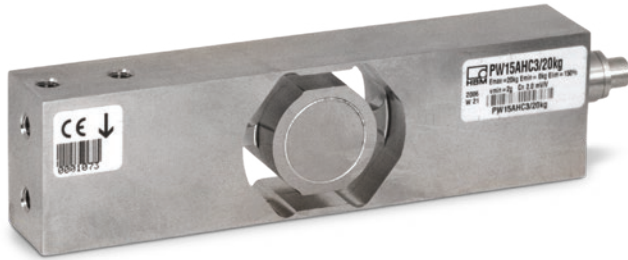

Picture is a representation of actual product.

Approvals



Order Information

Load Rating	Part #	Est. Weight	Price
10 kg	101915	3 lb	\$715.50
20 kg	101916	3 lb	\$715.50
50 kg	101917	3 lb	\$715.50
100 kg	101918	3 lb	\$715.50

Dimensions

Rated Capacity	B	E	F	G	H	I	J
kg/mm							
10 to 100	19.0	25.0	75.0	100.0	17.5	40.0	150.0

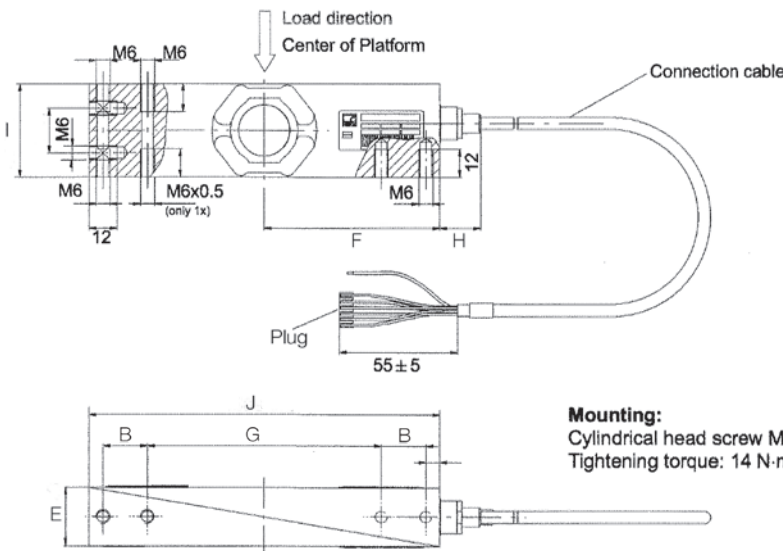

Interchangeable Products

RICE LAKE WEIGHING SYSTEMS
RLPWM15.....page 154
 FLINTEC®
PC4.....page 218

Specifications

- Full Scale Output:**
2.0 mV/V
- Output Resistance:**
350 (± 10) ohm
- Input Resistance:**
380 (± 15) ohm
- Material/Finish:**
Stainless steel
- Temperature:**
Compensated range
14 °F to 104 °F (-10 °C to 40 °C)
Operating range
0 °F to 150 °F (-18 °C to 65 °C)
- Seal Type:**
Hermetically sealed, IP69K
- Safe Overload:**
150% full scale
- Rated Excitation:**
5 to 10 VDC (15 V maximum)
- Combined Error:**
0.02% full scale
- Insulation Resistance:**
1,000 megohm
- Cable Length:**
10 ft
- Cable Diameter:**
0.212 in PVC jacket
- Cable Color Code:**
Blue +Excitation
Black -Excitation
White +Signal
Red -Signal
Green +Sense
Grey -Sense
- Warranty:**
One-year limited
- Approvals:**
NTEP
OIML
FM

HBK



Picture is a representation of actual product.

Approvals



Order Information

Load Rating	Part #	Est. Weight	Price
7 kg	36185	2 lb	\$387.00
10 kg	36186	2 lb	\$387.00
15 kg	36187	2 lb	\$387.00
30 kg	36188	2 lb	\$387.00
60 kg	36189	2 lb	\$387.00
100 kg	68551	2 lb	\$387.00
150 kg	69345	2 lb	\$387.00

Dimensions

Rated Capacity	A	B	C	D	E	F	G
kg/mm							
7 to 15	30.2	139.7	19.1	6.4	88.9	1/4-20 UNC	19.1
30 to 60	30.2	139.7	19.1	6.4	88.9	1/4-20 UNC	23.9
100 to 150	30.2	139.7	22.3	7.8	79.2	3/8-16 UNC	30.7

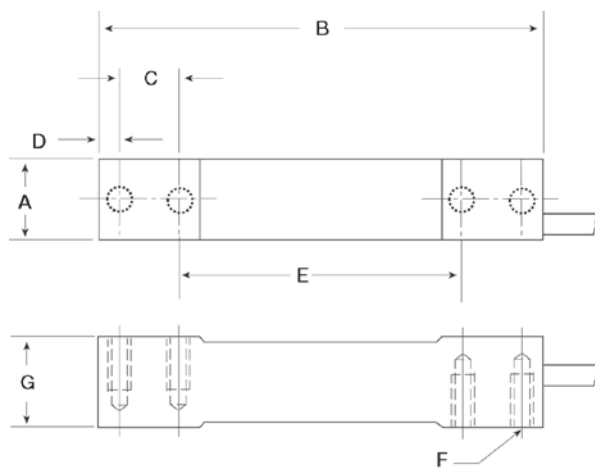

Interchangeable Products

- RICE LAKE WEIGHING SYSTEMS
RL1380.....page 164
 FLINTEC®
PC3.....page 217

Specifications

Full Scale Output:
2.0 mV/V

Output Resistance:
359 (± 10) ohm

Input Resistance:
390 (± 15) ohm

Material/Finish:
Stainless steel

Temperature:
Compensated range
14 °F to 104 °F (-10 °C to 40 °C)
Operating range
0 °F to 150 °F (-18 °C to 65 °C)

Seal Type:
Environmentally sealed, IP67

Safe Overload:
150% full scale

Rated Excitation:
5 to 10 VDC (15 V maximum)

Combined Error:
0.03% full scale

Insulation Resistance:
5,000 megohm

Cable Length:
10 ft

Cable Diameter:
0.190 in
Polyurethane jacket

Deflection:
<0.4 mm full scale

Cable Color Code:
Green +Excitation
Black -Excitation
White +Signal
Red -Signal
Yellow Shield

Warranty:
One-year limited

Approvals:
FM
NTEP
OIML



HBK

