

BenchMark® HDP

Heavy-duty Portable Scale

BENCH SCALES



Standard Features

- Mild steel base construction
- 304 stainless steel cover
- Indicator stand for mounting 380 Synergy

Wheel model

- Polyurethane rubber leveling feet with stainless steel stems
- 8-inch diameter preformed rubber wheels with ball bearings

Caster model

- 3 1/2 in diameter preformed rubber casters, two fixed, two swivel with lock

Specifications

Load Cell:

IP67, environmentally sealed
Aluminum

Output Impedance:

350 ohm

Maximum Overload:

200%

Overload Protection:

Five-point, independently adjusted

Scale Frame:

Mild steel powder-coated black

Scale Cover:

AISI304L, straight line finish, Ra=45 ± 10

Cable Length:

10 ft (3 m)

Temperature:

Compensated:
14 °F to 104 °F (-10 °C to 40 °C)

Warranty:

Two-year limited

Approvals:

NTEP 06-010, Class III 5,000 d
Measurement Canada AM-5625

Approvals



Measurement
Canada
Approved

Part Number/Price

Part #	Capacity	Platform Dimensions	Est. Weight	Price
Wheel Model				
97072	250 lb (125 kg)	24 × 24 × 8.75 in	275 lb	Consult
97073	500 lb (225 kg)	24 × 24 × 8.75 in	275 lb	Consult
Caster Model				
97074	250 lb (125 kg)	24 × 24 × 9.31 in	290 lb	Consult
97075	500 lb (225 kg)	24 × 24 × 9.31 in	290 lb	Consult

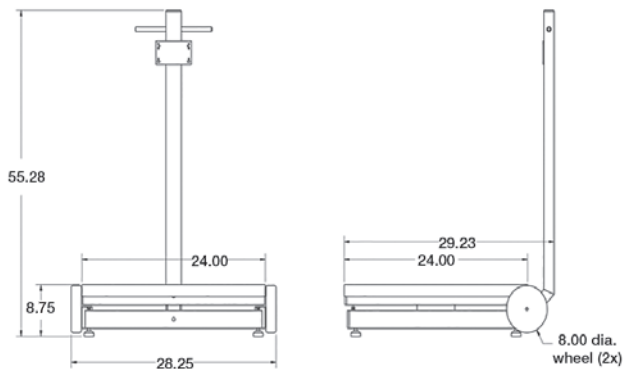

Wheel Model

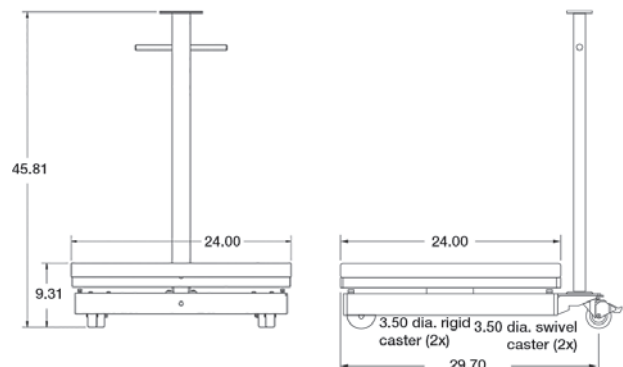

Caster Model