

1280 Enterprise™ Series

Color Touchscreen Programmable Indicator

Version 2.09

Installation Manual



© Rice Lake Weighing Systems. All rights reserved.

Rice Lake Weighing Systems® is a registered trademark of
Rice Lake Weighing Systems.

All other brand or product names within this publication are trademarks or
registered trademarks of their respective companies.

All information contained within this publication is, to the best of our knowledge, complete and
accurate at the time of publication. Rice Lake Weighing Systems reserves the right to make
changes to the technology, features, specifications and design of the equipment without notice.

The most current version of this publication, software, firmware and all other product
updates can be found on our website:

www.ricelake.com

Revision History

This section tracks and describes manual revisions for awareness of major updates.

Revision	Date	Description
B	June 2, 2026	Established revision history

Table i. Revision Letter History



Technical training seminars are available through Rice Lake Weighing Systems. Course descriptions and dates can be viewed at www.ricelake.com/training or obtained by calling 715-234-9171 and asking for the training department.

Contents

1.0 Introduction	7
1.1 Safety	7
1.2 Disposal	8
1.3 FCC Compliance	8
1.4 Features	8
1.4.1 Other Features	8
1.4.2 Enclosure Types	9
1.4.3 Option Cards	9
1.5 Weigh Mode	10
1.6 Numeric/Alpha Entry	11
1.7 Main Menu User Interface	12
1.7.1 Calibration	12
1.7.2 Setpoints	13
1.7.3 Audit Trail	13
1.7.4 Language	14
1.7.5 Return to Weigh Mode	14
1.8 Indicator Virtual Keypad Operation	14
1.8.1 Toggle Gross/Net Mode	15
1.8.2 Toggle Units	15
1.8.3 Zero Scale	15
1.8.4 Tare	15
1.8.5 Print Ticket	15
1.8.6 Diagnostics	15
1.8.7 Accumulator Functions	16
1.8.8 Peak Hold	16
1.8.9 Softkey Setup	16
1.9 Keypad Operations	17
1.9.1 Navigation Keys	17
1.9.2 Numeric Keypad	17
1.9.3 Toggle Gross/Net Mode	17
1.9.4 Toggle Units	17
1.9.5 Zero Scale	17
1.9.6 Tare	18
1.9.7 Print Ticket	18
1.9.8 Accumulator Functions	18
1.10 Alibi Storage	19
1.11 Peak Hold	19
1.12 Rate Of Change	19
1.13 Setpoint Value Entry	19
1.14 Softkey Operations	20
1.15 Error Conditions	20
2.0 Installation	21
2.1 Unpacking	21
2.2 Mounting/Assembly	21
2.2.1 Torque Values	21
2.2.2 Universal Mount Enclosure with Tilt Stand	22
2.2.3 Wall Mount Enclosure	26



Rice Lake continually offers web-based video training on a growing selection of product-related topics at no cost. Visit www.ricelake.com/webinars

2.2.4	Panel Mount Installation	29
2.3	Cable Connections	34
2.3.1	Water/Dust Tight Cord Grips	34
2.3.2	Shield Grounding Through Cord Grips	35
2.3.3	Shield Grounding with Clamp and Ground Stud	35
2.3.4	ESD Grounding for Touch Only Models	36
2.3.5	Load Cells	38
2.3.6	Serial Communications	39
2.3.7	CPU Digital I/O Wiring	40
2.4	Wiring Schematics	41
2.4.1	Key Pad Model	41
2.4.2	Touch Screen Only (Virtual Keypad)	42
2.5	Configuration Methods	42
2.6	CPU Board Replacement	43
2.6.1	Remove CPU Board from Face Plate	43
2.7	Rechargeable Coin-Cell Battery Replacement	44
2.8	Power Supply Replacement	45
2.9	Replace Fan Plate and Back Plane	46
2.10	Replacement Parts	47
2.11	Label Legend	56
3.0	Configuration Menu	57
3.1	Access Setup Parameters	57
3.2	Access Configuration Menu – Sealed Indicator	57
3.3	Configuration Menu	59
4.0	Specifications	61



Technical training seminars are available through Rice Lake Weighing Systems. Course descriptions and dates can be viewed at www.ricelake.com/training or obtained by calling 715-234-9171 and asking for the training department.



Rice Lake continually offers web-based video training on a growing selection of product-related topics at no cost. Visit www.ricelake.com/webinars

1.0 Introduction

This manual is intended for use by service technicians responsible for installing and servicing 1280 Enterprise Series digital weight indicators.



NOTE: The full 1280 Enterprise Series Technical Manual is available at www.ricelake.com.



Manuals are available from Rice Lake Weighing Systems at www.ricelake.com/manuals

Warranty information is available at www.ricelake.com/warranties

1.1 Safety

Safety Definitions:



DANGER: Indicates an imminently hazardous situation that, if not avoided, will result in death or serious injury. Includes hazards that are exposed when guards are removed.



WARNING: Indicates a potentially hazardous situation that, if not avoided, could result in serious injury or death. Includes hazards that are exposed when guards are removed.



CAUTION: Indicates a potentially hazardous situation that, if not avoided, could result in minor or moderate injury.



IMPORTANT: Indicates information about procedures that, if not observed, could result in damage to equipment or corruption to and loss of data.

General Safety



Do not operate or work on this equipment unless this manual has been read and all instructions are understood. Failure to follow the instructions or heed the warnings could result in injury or death. Contact any Rice Lake Weighing Systems dealer for replacement manuals.



WARNING: Failure to heed could result in serious injury or death.

Some procedures described in this manual require work inside the indicator enclosure. These procedures are to be performed by qualified service personnel only.

Do not allow minors (children) or inexperienced persons to operate this unit.

Do not operate without enclosure completely assembled.

Do not place fingers into slots or possible pinch points.

Do not use this product if any of the components are cracked.

Do not make alterations or modifications to the unit.

Do not remove or obscure warning labels.

Do not submerge.

Before opening the unit, ensure the power cord is disconnected from the power source.

Disconnect all power before servicing. Multiple power sources may be present. Failure to do so may cause property damage, personal injury or death.

For permanently connected equipment, a readily accessible disconnect device shall be incorporated in the building installation wiring.

Pluggable units must be installed near the socket/outlet and be easily accessible.

Use copper or copper-clad aluminum conductors only.



IMPORTANT: All included batteries intended for sale in the EU market are classified as "Portable Batteries for General Use" and comply with European Battery Regulation (EU) 2023/1542.

1.2 Disposal



Product Disposal

The product must be brought to appropriate separate waste collection centers at the end of its life cycle.

Proper separate collection to recycle the product helps prevent possible negative effects on the environment and to health, and promotes the recycling of the materials. Users who dispose of the product illegally shall face administrative sanctions as provided by law.

Battery Disposal

Dispose of batteries at appropriate waste collection centers at the end of their life cycle in accordance with local laws and regulations. Batteries and rechargeable batteries may contain harmful substances that should not be disposed of in household waste. Batteries may contain harmful substances including but not limited to: cadmium (Cd), lithium (Li), mercury (Hg) or lead (Pb). Users who dispose of batteries illegally shall face administrative sanctions as provided by law.



WARNING: Risk of fire and explosion. Do not burn, crush, disassemble or short-circuit lithium batteries.

1.3 FCC Compliance

United States

This equipment has been tested and found to comply with the limits for a Class A digital device, pursuant to Part 15 of the FCC Rules. These limits are designed to provide reasonable protection against harmful interference when the equipment is operated in a commercial environment. This equipment generates, uses and can radiate radio frequency energy and, if not installed and used in accordance with the instruction manual, may cause harmful interference to radio communications. Operation of this equipment in a residential area is likely to cause harmful interference in which case the user will be required to correct the interference at his own expense.

Canada

This digital apparatus does not exceed the Class A limits for radio noise emissions from digital apparatus set out in the Radio Interference Regulations of the Canadian Department of Communications.

Le présent appareil numérique n'émet pas de bruits radioélectriques dépassant les limites applicables aux appareils numériques de la Class A prescrites dans le Règlement sur le brouillage radioélectrique édicté par le ministère des Communications du Canada.

1.4 Features

Features of the 1280 include:

- Support for up to eight scales (combination of analog load cell, total, serial scales or program scales)
- Eight programmable Digital I/O bits available on the CPU board (connector J1) including onboard pulse input pins, with 24 additional per option card
- Two communication ports which support RS-232, RS-485 and RS-422
- Two USB host ports
- One USB device port
- AC or DC power options
- Ethernet – wired, Wi-Fi and Wi-Fi Direct
- Wireless Personal Area Network functionality not accessible in Version 2.00

1.4.1 Other Features

- Built in Web Server for remote access to screens
- Configurable print formats can be defined for up to 1000 characters; additional print formats can be created with iRite®
- Includes the iRite programs and source codes: truck in/out, recipe batching, counting, checkweighing and filling/dosing
- 100 configurable setpoints
- The 1280 is NTEP, OIML, Measurement Canada and Australian Government certified (see [Section 4.0 on page 61](#))

1.4.2 Enclosure Types

- Universal
- Panel Mount – numeric keypad
- Panel Mount – touch-only (7 in and 12 in display)
- Wall Mount

1.4.3 Option Cards

The CPU board provides six slots for installing scale or other option cards. Available option cards include:

- Single- and dual-channel scale cards to drive up to sixteen 350 ohm load cells per card; scale cards support both 4- and 6-wire load cell connections
- Single- and dual-channel analog output card for 0–10 VDC, 0–20 mA or 4–20 mA tracking of gross or net weight values
- 24-channel digital I/O expansion card
- Dual channel serial port card (with RS-232, RS-422 and RS-485)
- Dual channel analog input card for ± 100 mV, ± 10 VDC, 0–20 mA or 4–20 mA
- 4-channel relay card
- CompactCom card which supports EtherNet/IP™, DeviceNet®, PROFINET, Profibus® DP, Modbus TCP, and EtherCAT® networks

1.5 Weigh Mode

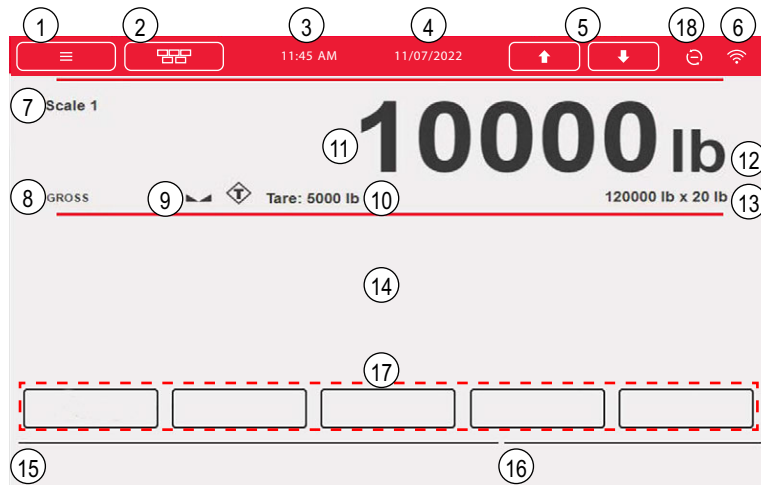



Figure 1-1. Weighing Mode Display Screen

 **NOTE:** The display illustrations in this manual are for reference only, they can be different from default illustrations depending on the colors, graphics or programs which have been loaded.

Item No.	Description
Status Bar	
1	Menu key – press to enter setup menus and audit trail information
2	Virtual keypad – press to enter; Zero, Tare, Gross/Net, Print, Units and Diagnostics keys are identical to the physical keys located on the front panel
3	Current time – press to set the time NOTE: Current time must be set accurately for some functions to work
4	Current date – press to set the date NOTE: Current Date must be set accurately for some functions to work
5	Scale arrows – use to scroll through the attached scales in the current scale area (up to eight scales)
6	Wi-Fi Symbol - indicates Wi-Fi signal strength; when faded, Wi-Fi is not connected or out of range; press on the symbol to display the Network Information Screen which includes information on Wired Ethernet, Wi-Fi and Wi-Fi Direct; allows restart all network connections
18	Net Update firmware status icon - indicates if a newer Net Update firmware is available
Weight Display Area	
7	Current scale – number of currently displayed scale
8	Gross/Net – current weighing mode
9	Standstill icon – indicates scale is stable
10	Tare – weight of tare in system
11	Weight reading for current scale
12	Unit of measure
13	Capacity and division size (values are for illustration only)
14	Application area – contains configuration of widgets (text boxes, bar graphs, icons and others)
15	Display line for text (messages from an iRite program)
16	System messages or status (batch running, print queued and others)
Softkeys	
17	Softkeys – five softkeys which can be setup from the default list, or user defined custom text and iRite programming functionality; these can be removed for more screen customization

Table 1-1. Weigh Mode Display

 **NOTE:** When a system reset is performed (Version 1.05 and later) the Weigh Mode display is populated with a scale widget and a softkey widget. This gives end users access to softkey setup without having to use EDP commands or revolution.

1.6 Numeric/Alpha Entry

When data entry is required, a keyboard or a numeric keypad displays on the screen. The indicator's front panel is also equipped with a numeric keypad.

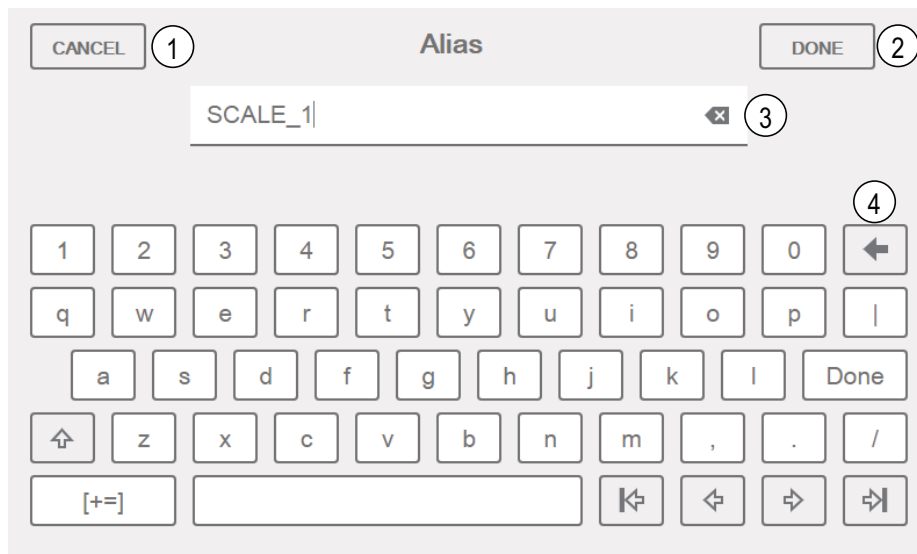

Figure 1-2. On-screen Alphanumeric Keyboard

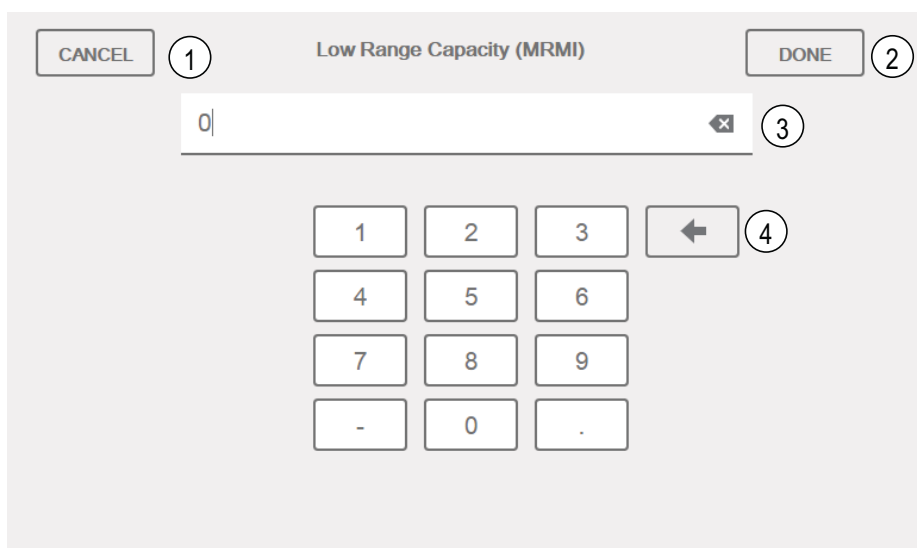

Figure 1-3. On-screen Numeric Keypad

Item No.	Description
1	Cancel – exits keyboard
2	Done – completes keyboard entry
3	Clear – deletes everything in the prompt line
4	Backspace – deletes one character at a time

Table 1-2. Keyboard Descriptions

1.7 Main Menu User Interface

The Main Menu allows the operator access to Configuration, Calibration, Setpoint Values, Audit Trail and Language.

From the weigh mode, press  to enter the main menu.

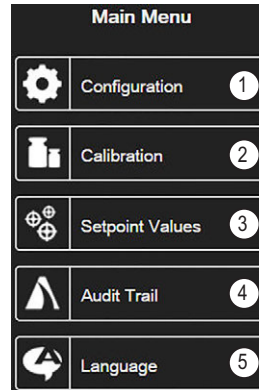







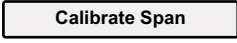
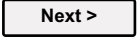
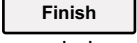

Figure 1-4. Main Menu User Interface

Item No.	Description
1	Configuration – may be inaccessible to the operator by password protection
2	Calibration – allows the operator to perform a calibration
3	Setpoint Values – access to setpoint targets and settings
4	Audit Trail – view number of configuration and calibration edits, plus the last calibration date
5	Language – allows scale language to be changed

Table 1-3. Main Menu User Interface

1.7.1 Calibration

Use the following steps to perform a standard calibration on a scale.

1. Select the scale to be calibrated and enter the calibration menu.
2. Press .
3. Select the method of calibration. Press .
4. Select if chains, hooks or other items are being used with the weights during calibration.
5. Press .
6. Remove all weight from the scale except for chains and hooks (if used).
7. Press . The current weight and **Zero Calibration Complete** displays.
8. Press .
9. Enter span weight for the value of the calibration test weights used to calibrate the scale. This is required prior to running the span calibration.
10. With the test weight on the scale platform and the test weight value entered into the calibration weight window, the corresponding scale span value is ready to be calibrated.
11. Press . The current span weight displays.
12. Press . Calibration results display.
13. Press . Display returns to Calibration menu.
14. If hooks or chains were used during calibration, remove these and the test weights from the scale. The re-zero function is used to remove a calibration offset when hooks or chains are used to hang the test weights during both zero and span calibration.
15. Press .

1.7.2 Setpoints

Targets are a set of values which when met, cause the setpoint to trip.

Parameter	Default	Description
Value	0	Setpoint Value: Weight-based – specifies the target weight value, 0–9999999 Time-based – specifies time in 0.1 second intervals, range 0–65535 Counter – specifies the number of consecutive batches to run, range 0–65535
Source	Scale 1	Select Scale 1–8
Trip	Higher	Specifies if the setpoint is satisfied when the weight is higher or lower than the setpoint value, within a band established around the value or outside of the band; in a batch sequence with: <ul style="list-style-type: none"> • Trip = Higher – associated digital output is active until the setpoint value is exceeded • Trip = Lower – output is active until the weight goes below the setpoint value • Trip = Inband – setpoint is satisfied when the weight is within a band established around the value • Trip = Outband – setpoint is satisfied when weight is outside a band established around the value, excluding the value

Table 1-4. Target Parameters

Settings allow the operator to select the mode of the setpoint (batch or free-running). If enabled, it can be accessed by softkey, for defining a name and optional prompt.

Parameter	Default	Description
Batch	Off	Specifies whether the setpoint is used as a batch (On) or continuous (Off) setpoint
Access	On	Specifies the access allowed to setpoint parameters display by pressing the Setpoint softkey in weigh mode; if set to Off , values can be displayed but not changed; if set to Hide , values do not display
Enable	On	Turns the setpoint on or off
Alias	--	Enter a name for the setpoint
Prompt	--	Alphanumeric message or prompt which can be displayed in a label widget

Table 1-5. Setpoint Parameters

1.7.3 Audit Trail

Audit trail support provides tracking information for configuration and calibration events. A separate calibration and configuration counter is provided for each scale; a single system configuration counter tracks all global changes applied to multiple scales.

To prevent misuse, unsaved configuration or calibration changes are counted as change events; restoration of the previous saved configuration or calibration is also counted.

Select to view the legally relevant version, the configuration counters and the calibration counters.

1. Press to send the audit trail data out the configured communications port (default is port 1).
2. Select to return to weigh mode.

Audit Trail			
Legally Relevant Version: 1.0			
Regulatory Agency: NTEP			
	Configuration	Calibration	Last Calibration Date
System	0		
Scale 1	5	4	02:34 PM 04/10/2015
Scale 2	2	2	02:34 PM 04/10/2015
Scale 3	2	0	
Scale 4	2	2	02:34 PM 04/10/2015
Scale 5	2	2	02:34 PM 04/10/2015
Scale 6	2	0	
Scale 7	2	2	02:34 PM 04/10/2015
Scale 8	0	0	

Figure 1-5. Audit Trail Screen

1.7.4 Language

The 1280 has 16 language choices, setting the language is only available in weigh mode. Configuration mode remains in English.

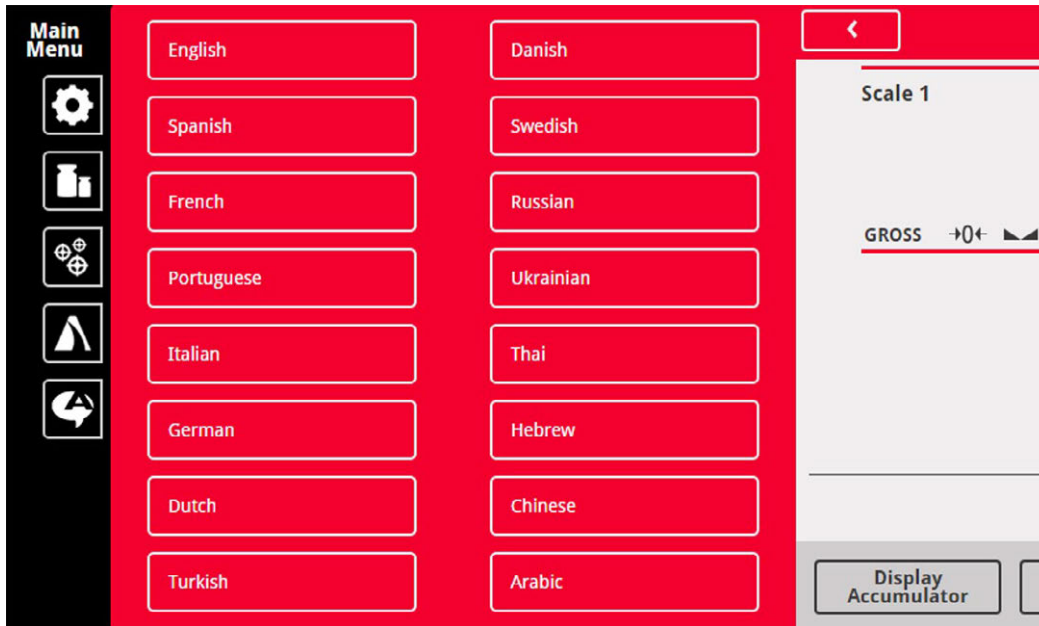
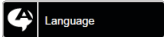



Figure 1-6. Language Selections

1. Press  to display the list of available languages.
2. Select the desired language.
3. Press  to save the selection and return to the weigh mode.

1.7.5 Return to Weigh Mode

When settings are complete for Configuration, Calibration or Setpoint Values, press .



displays for a few seconds then display returns to the weigh mode.

1.8 Indicator Virtual Keypad Operation

Press  to open the virtual keypad. **Zero**, **Tare**, **Gross/Net**, **Print**, **Units** and **Diagnostics** function the same as the physical keys located on the front panel of the keyed 1280.

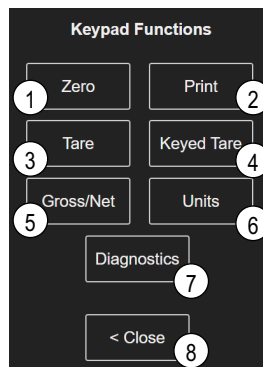

Figure 1-7. Virtual Keypad Functions

Keyed Tare is the equivalent to the keyed tare softkey. Press , a numeric keypad displays to enter a tare value.

1.8.1 Toggle Gross/Net Mode

Press  to toggle the display mode between gross and net.



- If a tared value is in the system, **Net** is displayed (net equals gross minus tare)
- If there is no tare in the system, **Gross** is displayed

1.8.2 Toggle Units

Press  to toggle between primary, secondary and tertiary units.

1.8.3 Zero Scale

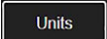
Use the following steps to zero the scale (if it is within the acceptable zero range).

1. In gross mode, remove all weight from the scale and wait for  to display.
2. Press . When  displays, the scale is zeroed.

1.8.4 Tare

Use the following instructions to acquire a tare, remove a stored tare and enter a tare using the display softkeys.

Acquire Tare

Used to store the weight currently on the scale as a tare weight and switch to net mode.

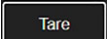
1. Place a container on the scale and wait for  to display.
2. Press . Net displays, indicating the weight has been tared.

Remove Stored Tare Value

Used to remove a stored tare value.

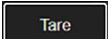
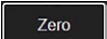
1. Remove all weight from the scale to obtain gross zero.
2. When  displays, press  (in OIML mode, press ). Gross displays.

Alternatively, remove a stored tare value using a keyed tare of zero.

Keyed Tare



Used to add a keyed tare.

1. Press . A numeric keypad displays.
2. Enter a value and press **Done**.

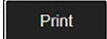
1.8.5 Print Ticket

Press  to send the gross or net ticket format to the configured serial, USB or Ethernet port associated with its ticket format. When displaying the accumulator, it prints the accumulator format.

To print tickets using auxiliary formats (1–20), press the  softkey (not part of virtual keypad).

1. Wait for  to display.
2. Press .
3. Enter an auxiliary format number (1–20) and press **Done** to send the data to the serial port.

1.8.6 Diagnostics

Displays iQUBE² diagnostics screen if installed.

1.8.7 Accumulator Functions

Acquiring Weight

If the accumulator is enabled while in configuration, weight is accumulated whenever a print operation is performed by:

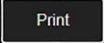
- Pressing 
- Activating a digital input print
- Receiving a KPRINT serial command
- iRite calling the PRINT () function
- Activating the accumulator with a setpoint

The scale must return to zero before the next accumulation.

Display or Clear the Accumulator

- A softkey can be programmed for each function
- A Display or Clear Accumulator Digital Input can be activated (ClearAccum0 iRite API, can be cleared with a setpoint)
- A serial command can be sent

Print the Accumulated Value

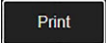
To print the accumulated value, press  while displaying the accumulator.

1.8.8 Peak Hold

Peak hold is used to determine, display and print the greatest weight reading during a weighing cycle.

There are three types of peak hold: automatic, manual and bi-directional.

To use the peak hold function:

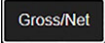
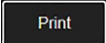
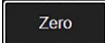
1. Tare the scale to put it into net mode.
2. Increase the weight. As the weight increases, the indicator captures and holds the highest weight recorded.
3. Press  to see the real live weight (as opposed to the peak hold weight).
4. Press  or  to clear the peak hold (it clears automatically when set to **Automatic Mode**).

1.8.9 Softkey Setup

The standard 7 in panel mount has front panel keys, navigation softkeys and a virtual keypad. The 7 in and 12 in key-less panel mounts only support a virtual keypad.

1. To enter navigation softkey designations for the 7 in panel mount, navigate to the main menu and select **Configuration/Features/Softkeys**.
2. Press .
3. Scroll to the desired softkey and press **Done**.

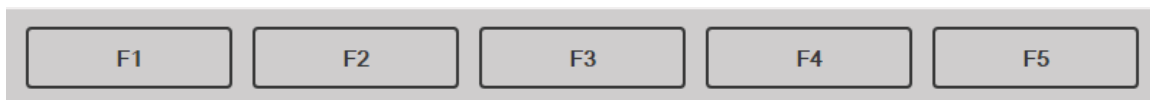

Figure 1-8. Softkeys

1.9 Keypad Operations

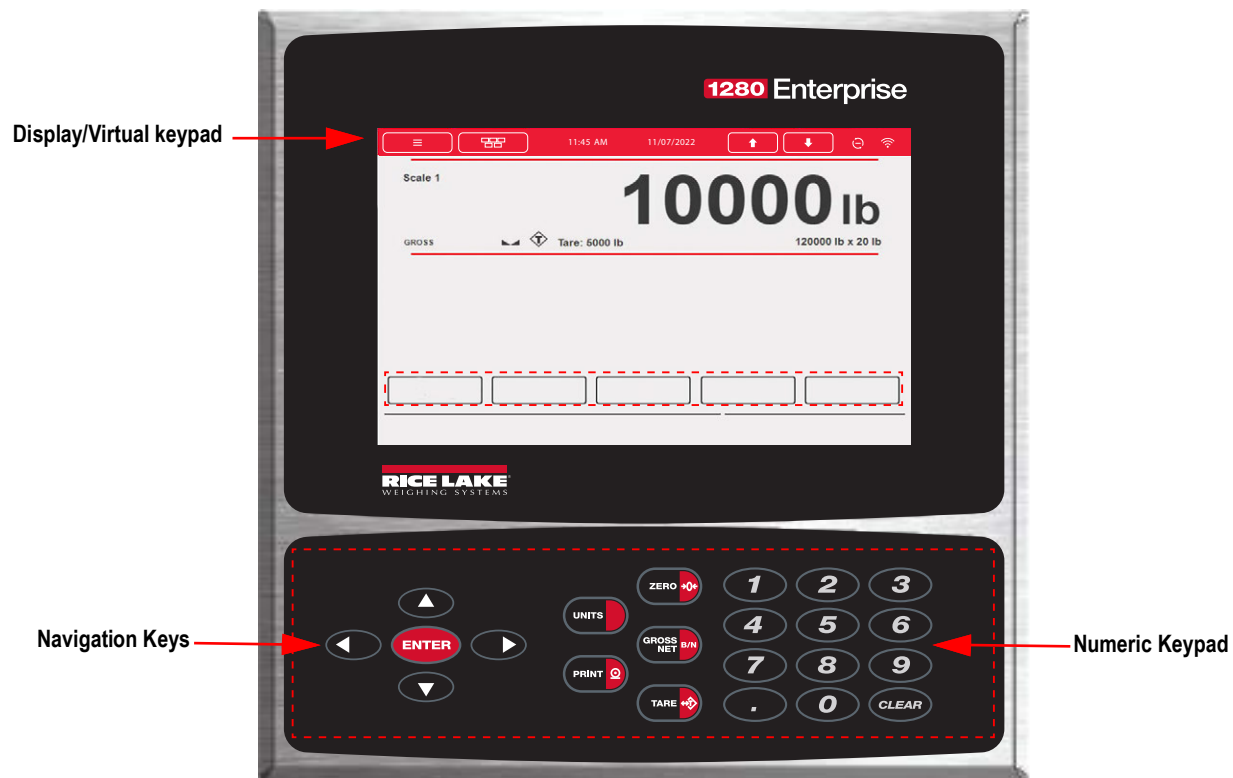

Figure 1-9. 1280 Front Panel

1.9.1 Navigation Keys

Navigation keys are primarily linked to iRite handlers. If no iRite handlers exist, the navigation keys toggle through a selection of displayed scales.

1.9.2 Numeric Keypad

Use the numeric keypad for entering numbers or keyed tares.

Press **CLEAR** to backspace when entering numbers/letters.

Press **ENTER** to save entries from the numeric keypad.

1.9.3 Toggle Gross/Net Mode

Pressing **GROSS B/N NET** toggles the display mode between gross and net.

- If a tared value is in the system, **Net** is displayed (net equals gross minus tare)
- If there is no tare in the system, **Gross** is displayed

1.9.4 Toggle Units

Pressing **UNITS** toggles between primary, secondary and tertiary units.

1.9.5 Zero Scale

Use the following instructions to zero the scale (if it is within the acceptable zero range).



1. In gross mode, remove all weight from the scale and wait for **▲▲** to display.
2. Press **ZERO →0←**. When **→0←** displays, the scale is zeroed.

1.9.6 Tare

Use the following instructions to acquire a tare, remove a stored tare and enter a tare using the keyboard.



Acquire Tare

Used to store the weight currently on scale as tare weight and switch to net mode.

1. Place container on scale and wait for  to display.
2. Press . **Net** displays indicating the weight has been tared.

Remove Stored Tare Value

Used to remove a stored tare value.

1. Remove all weight from the scale to obtain gross zero.
2. When  displays, press  (in OIML mode, press ). **Gross** displays.

Alternatively, remove a stored tare value using a **Keyed Tare** of zero.

Keyed Tare



Used to add a keyed tare.

1. Enter a value from the numeric keypad or an attached keyboard.
2. Press . **Net** displays indicating the keyed tare weight is in the system.

1.9.7 Print Ticket

Pressing  sends the gross or net ticket format to the configured serial, USB or Ethernet port associated with its ticket format. When displaying the accumulator, it prints the accumulator format.

To print tickets using auxiliary formats (1–20), enter the format number with the numeric keypad.

1. Wait for  to display.
2. Enter an auxiliary format (1–20).
3. Press  to send data to the serial port.

1.9.8 Accumulator Functions

Printing While in Accumulate

If the accumulator is enabled, weight is accumulated whenever a print operation is performed by:

- Pressing 
- Activating a digital input print
- Receiving a KPRINT serial command
- iRite calling the **PRINT ()** function
- Activating the accumulator setpoint

The scale must return to zero before the next accumulation

Display or Clear the Accumulator

- A softkey can be programmed for each function
- A **Display or Clear Accumulator Digital Input** can be activated
- A serial command can be sent

Print the Accumulated Value

To print the accumulated value, press  while displaying the accumulator.

1.10 Alibi Storage

Alibi storage is a database of past transactions listed by date. This allows previous print transactions to be recalled and reprinted. Alibi storage is enabled using the **Features** menu in configuration mode. Print transactions can be recalled by assigning a softkey to Alibi.



1. Press the **Alibi** softkey.
2. Use the arrows to scroll to the record required.
3. Press **Reprint** to print the record.
4. Repeat steps 2-3 until all records required have been printed.
5. Press **Done**.

1.11 Peak Hold

Peak hold is used to determine, display and print the greatest weight reading during a weighing cycle.

There are three types of peak hold: automatic, manual and bi-directional.

To use the peak hold function:

1. Tare the scale to put it into net mode.
2. Increase the weight. As the weight increases, the indicator captures and holds the highest weight recorded.
3. Press  to see the real live weight (as opposed to the peak hold weight).
4. Press  or  to clear the peak hold (unless it is set to automatic mode in which case it clears automatically).

1.12 Rate Of Change

Rate of change is expressed in weight per time unit (weight/time).

Example: lb/sec

To view the rate of change:

1. Press the **Display Rate of Change** softkey.
2. To return to the live weight, press **Display Rate of Change** again.

1.13 Setpoint Value Entry

Setpoints can be configured to perform actions or functions based on specified parameter conditions.

To change the setpoint value:

1. Press **Setup**.
2. Press the **Setpoint Values** key in the Main menu or from the black drop down list, or press the **Setpoint** softkey.
3. Press **Setpoint 1** to select the setpoint (1–100) for which the target value needs to be changed.
4. Press the red number of the setpoint in the table. It may be necessary to use the arrows at the bottom of the screen scroll through the setpoints.
5. Press **Value** to bring up the numeric entry keypad.
6. Enter the new target value and press **Done**.
7. Press **Settings** to toggle between enabled and disabled.
8. Press **Done** and **Save and Exit**.

1.14 Softkey Operations

Softkeys are configured to provide additional operator functions. Softkeys are displayed as digital buttons at the bottom of the touch screen display area, see [Figure 1-1 on page 10](#).

Softkey	Description
Blank	No softkey available
User Defined 1–10	Up to 10 softkeys can be created using one of the user defined options (22 characters or less available)
Time/Date	Displays current time and date; allows time and date change
Display Tare	Displays tare value in the entry prompt
Display Accumulator	Displays accumulator value, if enabled, for the current scale
Display Rate of Change	Displays rate-of-change value, if enabled, for the current scale
Setpoint	Displays a menu of configured setpoints; allows display and change of some setpoint parameters
Batch Start	Starts a batch from the current step if a Batch Run digital input is active or not defined; if a Batch Run digital input is defined and inactive, Batch Start resets the batch to the first step
Batch Stop	Stops an active batch and turns off all associated digital outputs; requires a Batch Start to resume processing
Batch Pause	Pauses an active batch and turns off all digital outputs except those associated with Concurrent and Timer setpoints; processing is suspended until the indicator receives a Batch Start signal; pressing the BATSTRT digital input, BATSTART serial command, Batch Start softkey or the StartBatch function (iRite) resumes the batch and re-energizes all digital outputs turned off by the Batch Pause
Batch Reset	Stops an active batch and resets the current step to the first batch step; all digital outputs associated with batch setpoints are deactivated; if a batch is stopped or paused, Batch Reset resets the current step to the first step
Select Scale	Enter the scale number (use numeric keypad) to be displayed for multi-scale applications, followed by the select scale softkey
Diagnostics	Opens the iQUBE ² diagnostics screen
Alibi	Allows previous print transactions to be recalled and reprinted
Contrast	Adjusts the screen backlight intensity
Test	Not available in version 1.00
Stop	Sends AuxFmt13 out its configured port to display a red light on a LaserLight
Go	Sends AuxFmt12 out its configured port to display a green light on a LaserLight
Off	Sends AuxFmt14 out its configured port to turn a LaserLight red/green light off
Display Unit ID	Displays the Unit ID in the lower left corner of the screen
Zero	Zeros the indicator
Gross/Net	Toggles between gross and net modes
Tare	Tare the scale by using the on screen numeric keypad
Keyed Tare	Tare the scale by using the on screen numeric keypad
Units	Toggles between primary, secondary and tertiary units
Print	Prints the configured print format
Aux Print	Auxiliary printing by entering the Auxiliary Format number (1–20)
Screen	Display a different screen by entering a value (1–99) and pressing the Screen softkey
Database	Accesses the import and export database feature from the weigh mode

Table 1-6. Configurable Softkeys

1.15 Error Conditions

Table 1-7 displays possible error codes and their remedies.

Symptom	Cause	Remedy
^^^^^^ in weight display	Over-range scale condition	Check scale for out-of-range conditions; Check all scale inputs for positive weight values
vvvvvv in weight display	Under-range scale condition	
- - - - - in weight display	Invalid Weight	

Table 1-7. Error conditions

2.0 Installation

This section describes procedures for connecting power, load cells, digital I/O and data communications cables to the 1280 indicator. Instructions for replacement of the circuit boards are also included, along with assembly drawings and replacement parts lists for the service technician.



Always use Caution when handling electrostatic sensitive devices (ESD).



CAUTION: Electrostatic sensitive device (ESD), observe handling precautions to prevent shock or damage caused from electrostatic discharge.



WARNING: Failure to heed the following statements could result in serious injury or death.

- Use a wrist strap for protection and damage to components from electrostatic discharge (ESD) when working inside the indicator enclosure.
- Procedures requiring work inside the indicator must be performed by qualified service personnel only.
- In the wall and universal mounts, the supply cord serves as the power disconnect. The power receptacle to the indicator must be accessible for these models.
- Disconnect all power supply cords before servicing.
- Input power source for the 1280-4D must be PS2/LPS (Class 2).

2.1 Unpacking

Immediately after unpacking, visually inspect the 1280 to ensure all components are included and undamaged. The shipping carton should contain the controller, display, parts kit, any options ordered with the unit and the appropriate manuals. If any parts were damaged in shipment, notify Rice Lake Weighing Systems and the shipper immediately.

2.2 Mounting/Assembly

There are three enclosure styles – universal mount, wall mount and panel mount.

2.2.1 Torque Values

It is important to maintain the following torques during installation and the replacement of hardware to ensure IP ratings are maintained.

Hardware	Where Used	Torque (in-lb)
Screw, Machine #6-32 UNC	Seal Wire Anchor	20
Screw, Fillister #10-32 UNF	Seal Wire Anchor	20
Screw, 1/4-20 UNC	Front Panel	22
Antenna Jack, 1/4-Extra Fine Thd	Antenna Jack	20
Breather Vent, M12 x 1.5	Breather Vent	10
Samtec Plug, Large Dia Thd	Bulkhead Connection	12
PG9 Cord Grip Nut	Metal Cord Grips	55
PG13.5 Cord Grip Nut	Metal Cord Grips	55
PG9 Cord Grip Cap	Metal Cord Cap	37
PG13.5 Cord Grip Cap	Metal Cord Cap	37
PG9 Plastic Cord Grip Nut	Power Cord	33
PG9 Plastic Cord Grip Cap	Power Cord	22

Table 2-1. Torque Values



IMPORTANT: Hardware must be torqued to the specified values to maintain IP rating. Torque values are both recommended and maximum. Both over and under torquing can compromise the IP rating.

2.2.2 Universal Mount Enclosure with Tilt Stand

Remove Shipping Bracket

The universal mount is shipped with a shipping bracket inside the enclosure to stabilize it during shipping.

1. Loosen the four screws securing the front door.

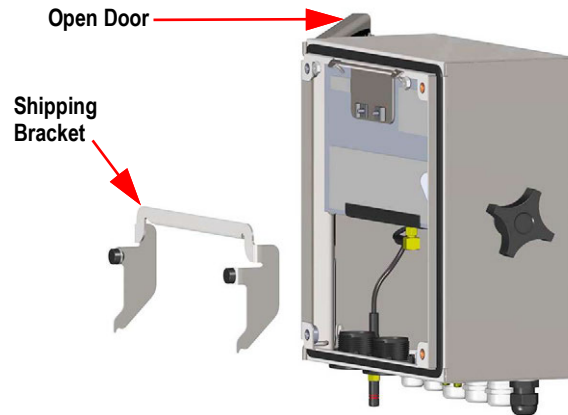

Figure 2-1. Remove Shipping Bracket

2. Pull the door and fully extend the hinge to swing the door open.
3. Remove the loose shipping bracket from the enclosure.



IMPORTANT: Shipping bracket must be removed to maintain IP ratings. Retain shipping bracket for future shipping needs.

Controller Disassembly



NOTE: The controller can be tilted up with the locking tab or it can be completely removed from the enclosure by removing the retaining wire bail.

1. Remove the large fillister screw in the back of the indicator to tilt or remove the controller. The seal must be broken for this purpose.



Figure 2-2. Open Cover

2. Loosen the four screws securing the front door.
3. Pull the door and fully extend the hinge to swing the door open.

4. Pull the locking tab to the left to release the controller assembly.
5. Remove the wires connected to the controller assembly.
6. Remove the retaining wire bail connected to the controller assembly. This only needs to be removed if the controller is being removed from the enclosure.
7. Lift controller assembly from the enclosure.

Reverse this procedure for reassembly. Upon reassembly, ensure display and keyboard wires are properly connected.



NOTE: To close the door to the universal enclosure, push the bail in and down so that it does not get caught on the controller assembly.

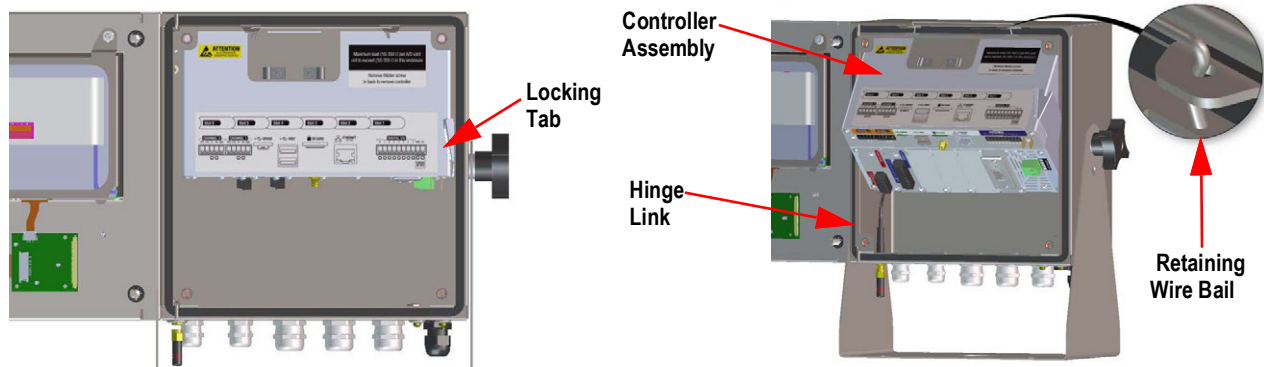

Figure 2-3. Remove CPU Assembly- Universal

Universal Mount Dimensions

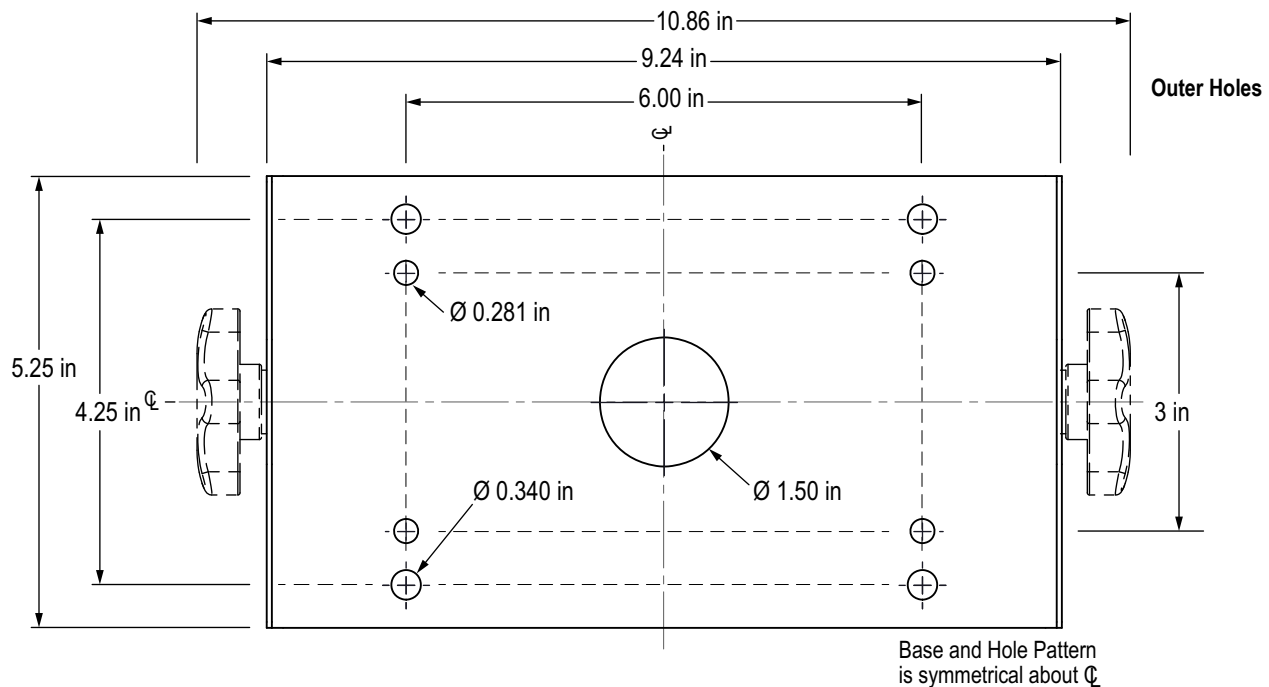

Figure 2-4. Universal Tilt Stand Hole Pattern Dimensions

The outer set of larger holes seat rubber feet or mount the stand to solid surfaces. The inner set of smaller holes mount the universal mount to an optional indicator stand (PN 126384 or PN 19352)



IMPORTANT: This illustration is not to scale and is for illustration purposes only. Use the dimensions to mark the holes for the universal mount, or use the bottom of the tilt stand as a template. Do not use this figure as a template.

Mount to Surface

The universal mount is shipped with a tilt stand and can be mounted on a wall, tabletop or any flat surface.

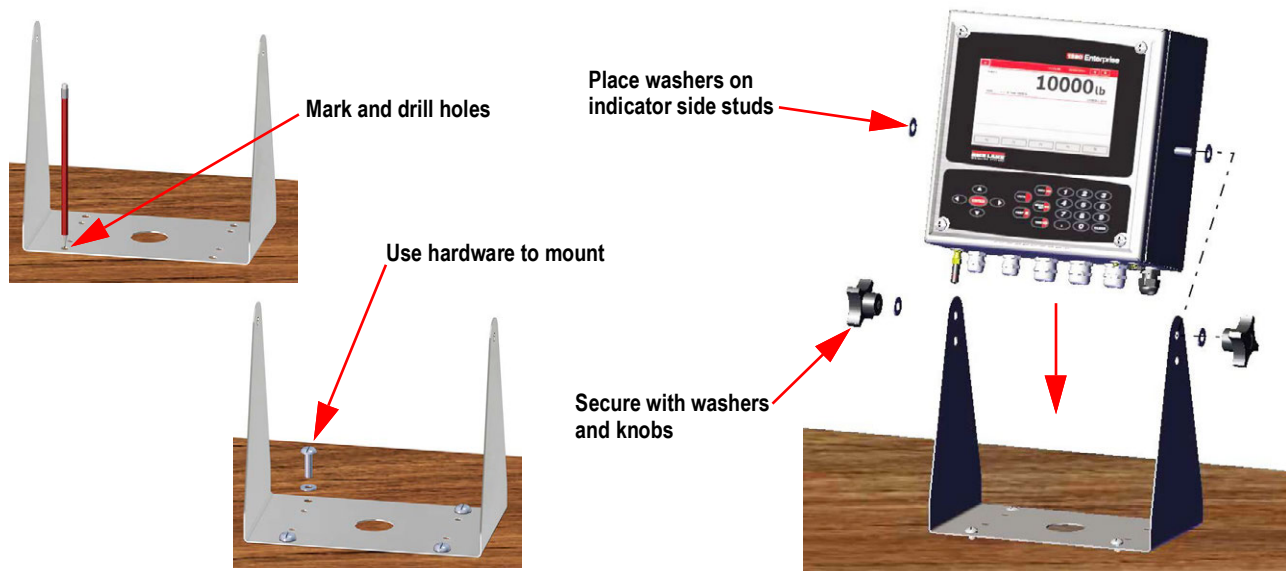

Figure 2-5. Mount Universal Enclosure

1. Using the tilt stand as a template, mark the screw locations. See [Figure 2-4 on page 23](#) for dimensions.



NOTE: The universal enclosure can mount to the same location where a 920i universal enclosure was mounted; the screw locations for the tilt stand are the same.

2. Drill holes for the screws.
3. Mount the tilt stand using the appropriate hardware (not included).
4. Place one washer on each side stud of the indicator enclosure.
5. Place the indicator side studs into the holes on the arms of the tilt stand.
6. Secure with remaining washers and hand knobs from the hardware kit.
7. Wire the indicator. See [Section 2.3 on page 34](#).

Mount to Stand

The universal mount tilt stand can be attached to an optional indicator stand (PN 126384 or PN 19352)

Sealing the Setup Switch

In certain Legal for Trade applications, it may be necessary to seal the indicator to restrict access from the setup switch. Use the following instructions to seal the universal enclosure.

IMPORTANT: The audit trail jumper (JP1) needs to be disabled, in the off (right) position, in order to seal the setup switch with a lead seal wire. Access is not prevented simply by sealing the setup switch.

1. Move the audit trail jumper (JP1) from the On position (by default) to the Off position (right most jumper position), see [Section 2.6 on page 43](#) for instructions on how to remove the CPU board (which is necessary to disable the audit trail jumper). This restricts access from the configuration menu through the front panel.
2. If not previously installed, install the large fillister screw in the back of the indicator.
3. Wrap the lead wire seal through the large fillister screw and the two smaller fillister screws in order to seal the indicator. This restricts access to the setup switch.

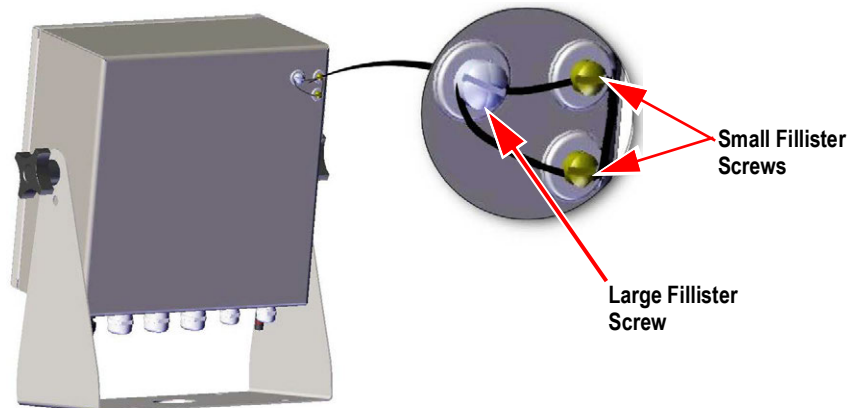

Figure 2-6. Seal the Setup Switch (Universal Mount)

Sealing the Front Door

In Legal for Trade applications, it is necessary to seal the indicator to restrict access to the internal hardware of the indicator. To seal the universal enclosure front door, wrap a lead wire seal through the large bottom right screw securing the front door and the two small fillister screws on the bottom of the enclosure. Alternatively, the A/D scale card includes fillister screws and a bracket that prevent the load cell cable from being disconnected.

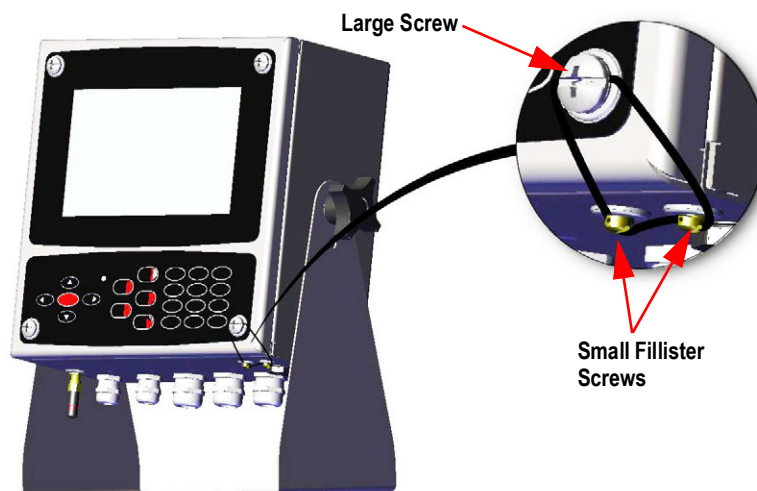

Figure 2-7. Seal the Front Door (Universal Mount)

2.2.3 Wall Mount Enclosure

- Using the wall mount as a template, mark the screw locations.



NOTE: The wall enclosure can mount to the same location where a 920i was mounted; the screw locations are the same.

- Drill holes for the screws.
- Mount using the appropriate hardware (not included).

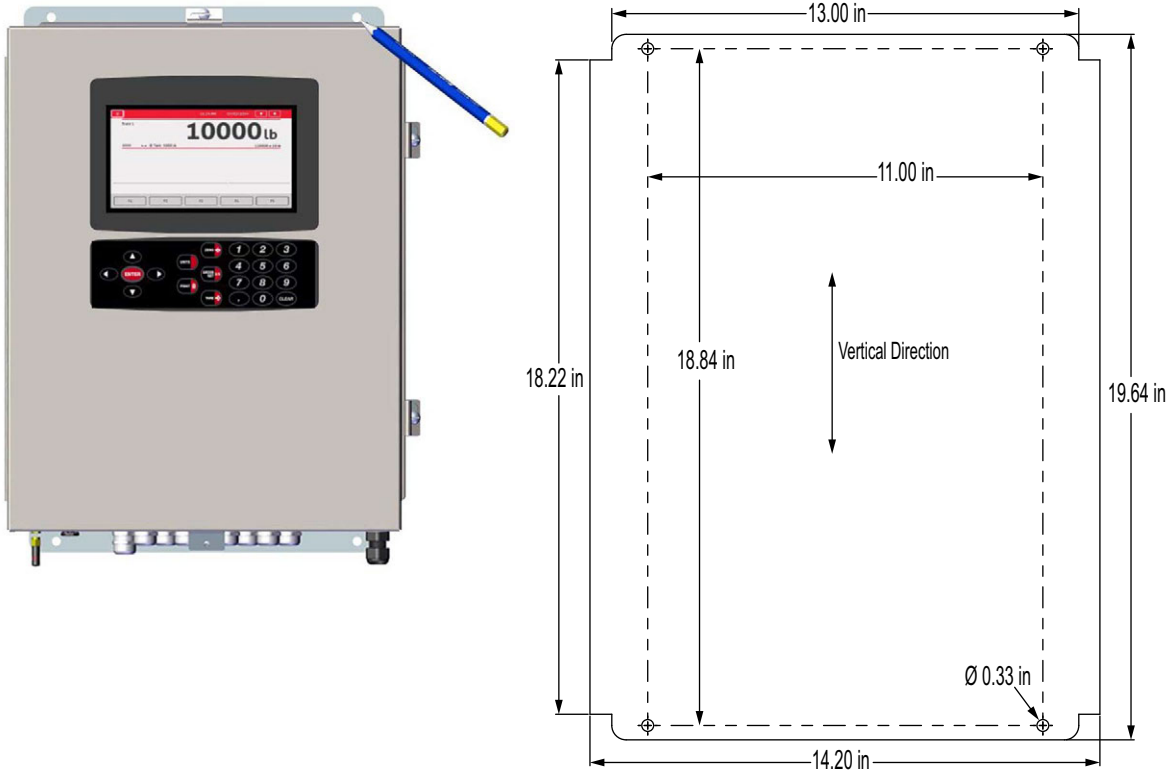

Figure 2-8. Wall Mount



IMPORTANT: This illustration is not to scale. It is for illustration purposes only. Use the dimensions to mark the holes for the wall mount. Do not use as a template.

Remove Shipping Bracket

- Loosen the four screws on the front door.
- Swing the door open.
- Remove the four screws securing the bracket in place.
- Remove bracket from the enclosure.

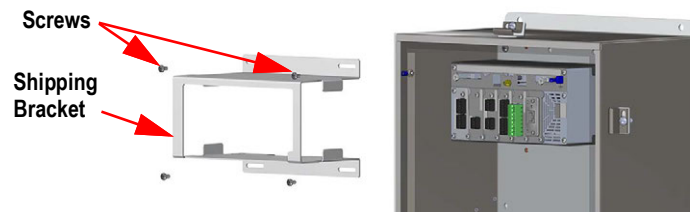

Figure 2-9. Remove Shipping Bracket

Controller Disassembly



Figure 2-10. Open Door

1. Loosen the four screws on the front door.
2. Swing the door open.
3. Remove the wires connected to the controller assembly.

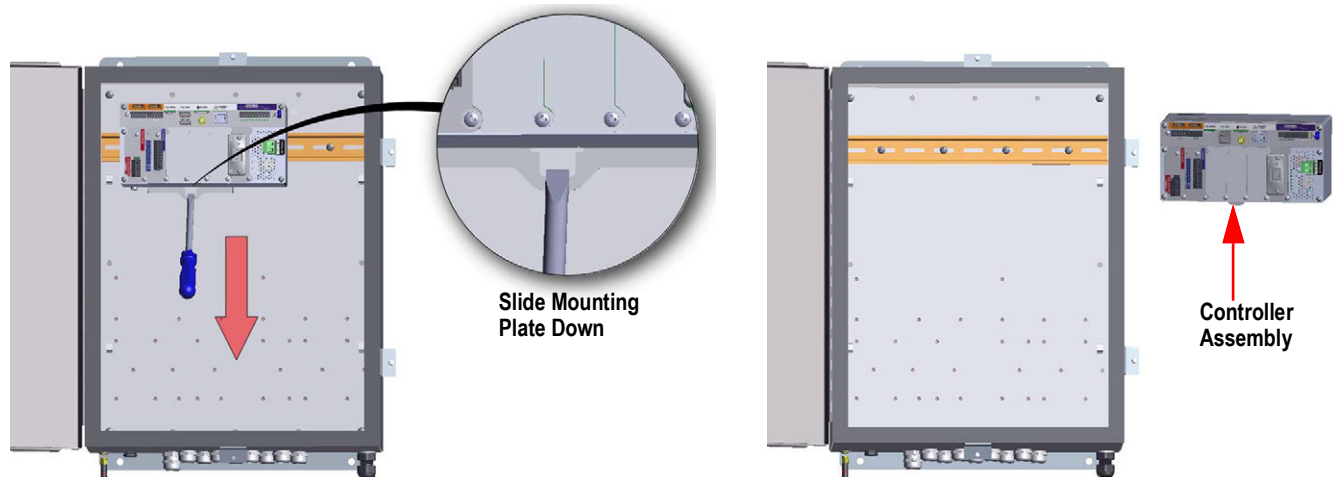

Figure 2-11. Remove Controller Assembly - Wall Mount

4. While supporting the controller assembly, use a screwdriver to slide the mounting plate down.
5. Lift the controller assembly up to remove it from the DIN rail and pull it out of the enclosure.

Reverse this procedure for controller assembly installation.



NOTE: When closing the door, tighten screws to 15 in-lb to ensure the enclosure is securely sealed.

Sealing the Setup Switch

In Legal for Trade applications, it is necessary to seal the indicator to restrict access to the setup switch. Use the following instructions to seal the wall mount enclosure.



IMPORTANT: The audit trail jumper (JP1) needs to be disabled, in the off (right) position, in order to seal the setup switch with a lead seal wire. Access is not prevented simply by sealing the setup switch.

1. Move the audit trail jumper (JP1) from the On position (by default) to the off position (right most jumper position), see [Section 2.6 on page 43](#) for instructions on how to remove the CPU board (which is necessary to disable the audit trail jumper). This will restrict access from the configuration menu through the front panel.
2. Wrap the lead wire seal through the large fillister screw and the bottom tab of the DIN rail clip to restrict access to the setup switch.

Enclosure hidden for illustration purposes, controller assembly does not need to be removed from the enclosure to seal the setup switch.

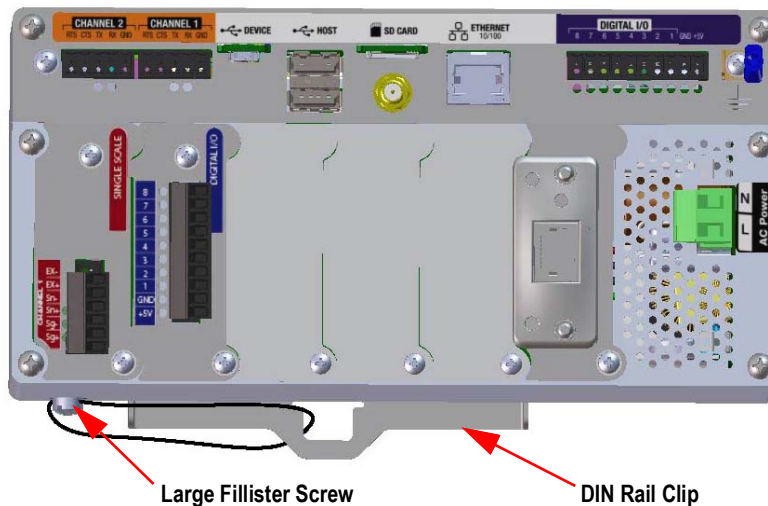

Figure 2-12. Seal the Setup Switch

Sealing the Front Door

In Legal for Trade applications, it is necessary to seal the indicator to restrict access to the internal hardware of the indicator. To seal the wall mount enclosure front door, wrap the lead wire seal through the large screw securing the front door and the hole in the edge of the door enclosure. Alternatively, the A/D scale card includes fillister screws and a bracket that prevent the load cell cable from being disconnected.

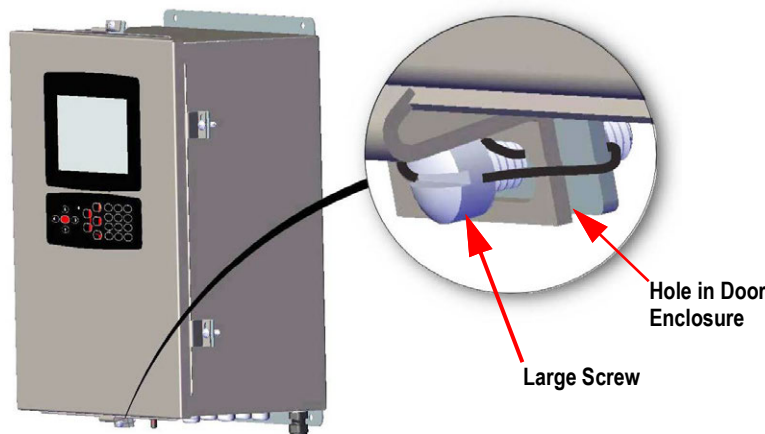

Figure 2-13. Seal the Front Door

2.2.4 Panel Mount Installation

The panel mount ships partially assembled. The display assembly must be removed from the DIN rail bracket for installation.

IMPORTANT: Models 1280-4A and 1280-4D are intended for installation in a restricted access location.

1. Remove the two screws securing the DIN rail bracket to the display assembly.
2. Use the DIN rail bracket as a template to mark the hole locations on the existing panel.
3. Drill holes at the marked locations. See Figure 2-15 below for exact measurements.
4. Place the display assembly and the DIN rail bracket on either side of the panel. Ensure that the DIN rail is horizontal.

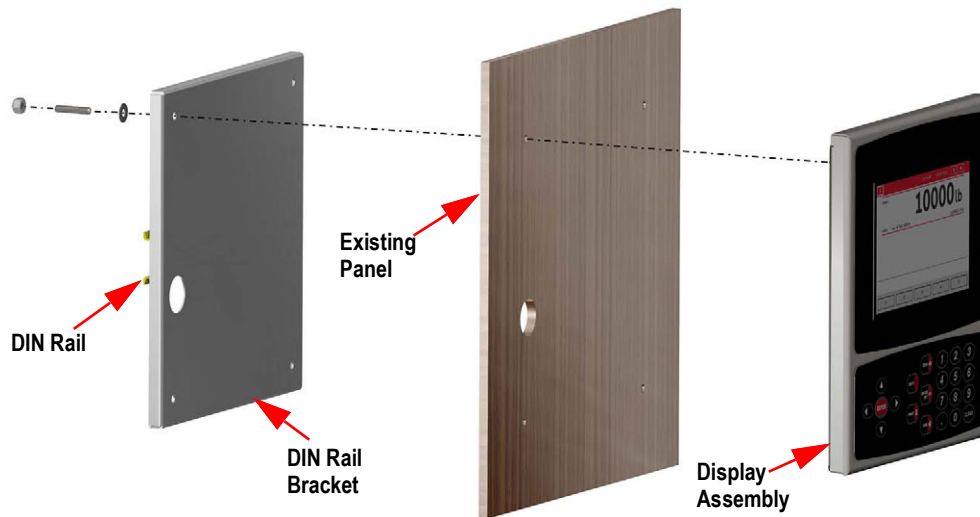

Figure 2-14. Panel Mount Installation

5. Use studs, nuts and washers to secure the display assembly to the DIN rail bracket.

DIN Rail Bracket Dimensions

IMPORTANT: The dimension illustrations are not to scale, they are for reference only. Use the dimensions to mark the holes for the panel mount, or use the DIN rail bracket as a template. Do not use figures as templates.

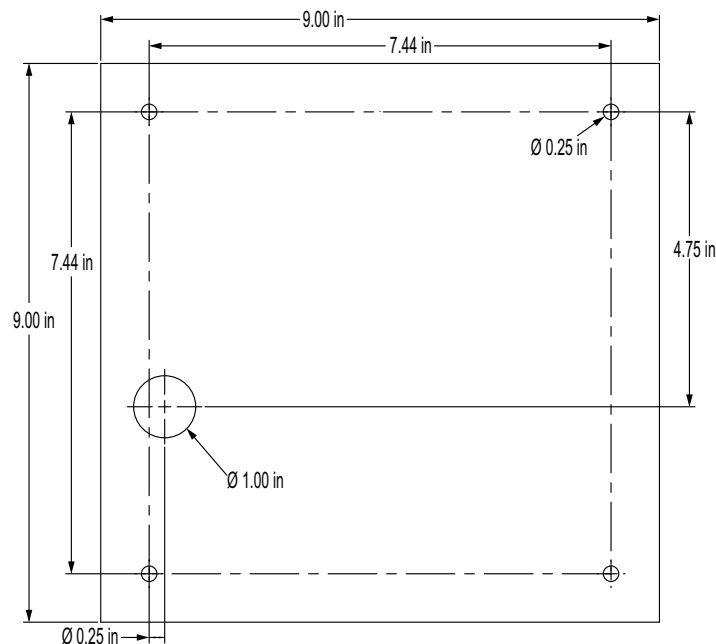

Figure 2-15. 7 Inch Panel Mount (with Keypad) Dimensions

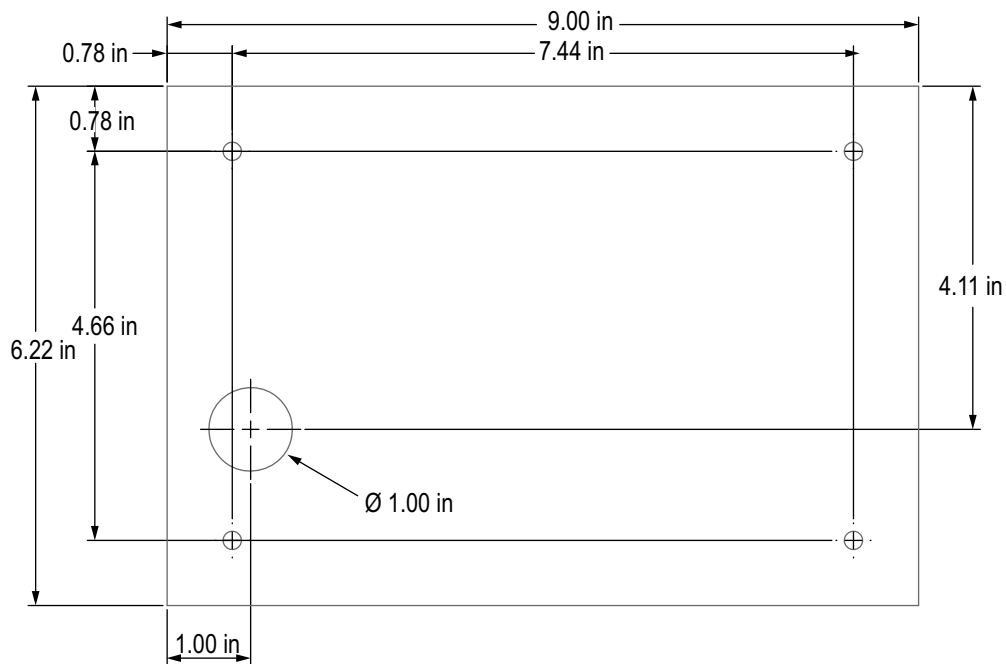

Figure 2-16. 7 in Touch-Only Panel Mount Dimensions

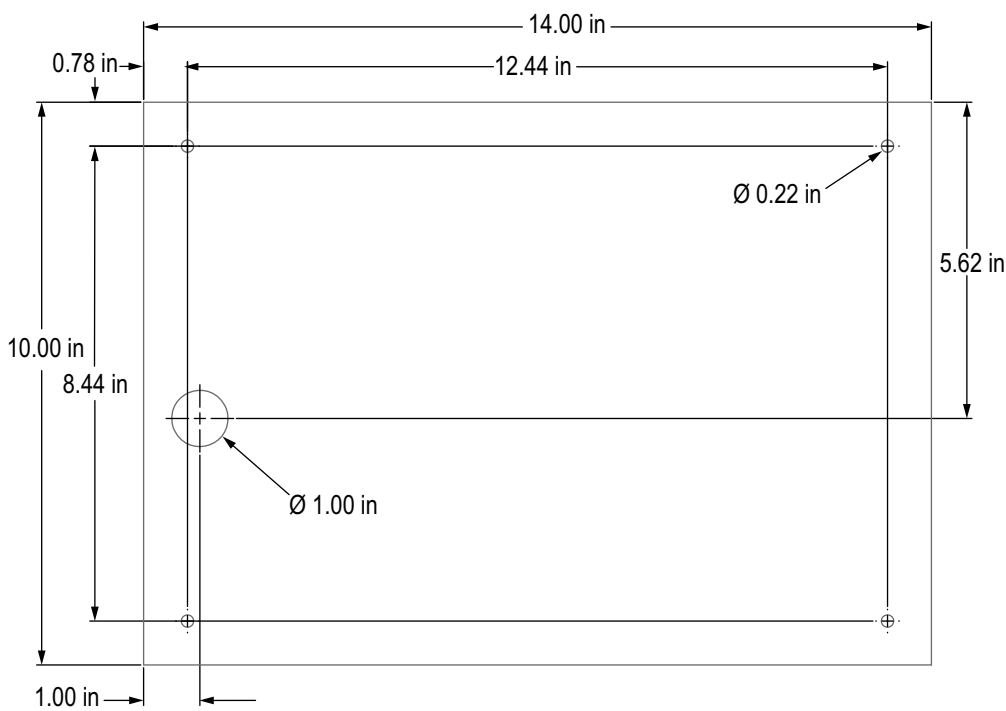

Figure 2-17. 12 in Touch-Only Panel Mount Dimensions

Install Grounding Bus Bar

The grounding bus bar is installed on the controller assembly for grounding purposes on the panel mount.

1. Remove the four corner screws from the controller assembly.
2. Align the bus bar to the screw holes and secure by reinstalling the screws.

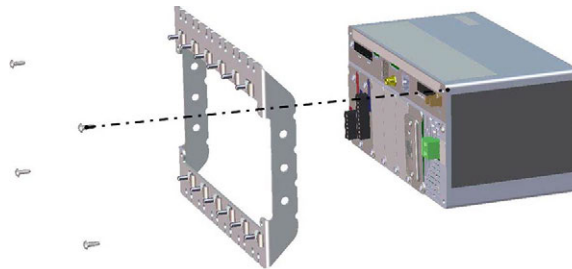

Figure 2-18. Grounding Bus Bar Installation



Figure 2-19. Controller Box Shield Grounding



NOTE: Reconnect cables to the controller which were disconnect before reinstalling it back into the enclosure.

Install Controller Assembly

The controller assembly can be mounted to a standard DIN rail.

1. Hook the mounting bracket on the back of the controller assembly onto the DIN rail.



NOTE: The controller assembly can be installed up to 30 in from the display assembly of the panel mount.

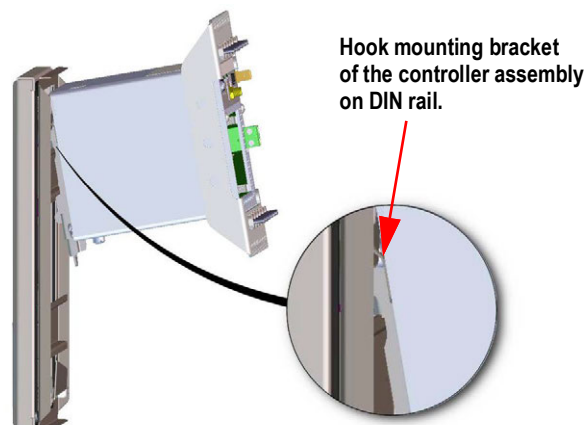

Figure 2-20. Hook Mounting Plate on DIN Rail

2. Push controller assembly against the DIN rail in order to engage the spring clip of the mounting bracket. The controller assembly locks onto the DIN rail.
3. Connect wiring. See [Section 2.3 on page 34](#).

Removing Controller Assembly

1. Disconnect wiring.
2. Supporting the controller assembly and use a screwdriver to slide the mounting plate down.
3. Unhook the controller assembly from the DIN rail bracket.
4. Carefully remove the controller assembly from the DIN rail bracket and release the mounting plate.

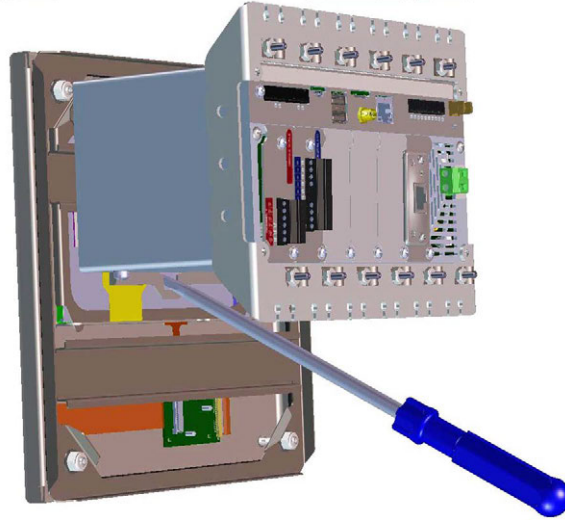

Figure 2-21. Remove Controller Assembly

Seal Setup Switch

In Legal for Trade applications, it is necessary to seal the indicator to restrict access to the setup switch. Use the following instructions to seal the panel mount enclosure.



IMPORTANT: The audit trail jumper (JP1) needs to be disabled, in the off (right) position, in order to seal the setup switch with a lead seal wire. Access is not prevented simply by sealing the setup switch.

Wrap the lead wire seal through the large fillister screw and through the bottom tab of the DIN rail clip to restrict access to the setup switch. Alternatively, the A/D scale card includes fillister screws and a bracket that prevent the load cell cable from being disconnected.

Enclosure and grounding bus bar hidden for illustration purposes. Controller Assembly does not need to be removed from the enclosure to seal the setup switch and the grounding bus bar can remain attached, if installed.

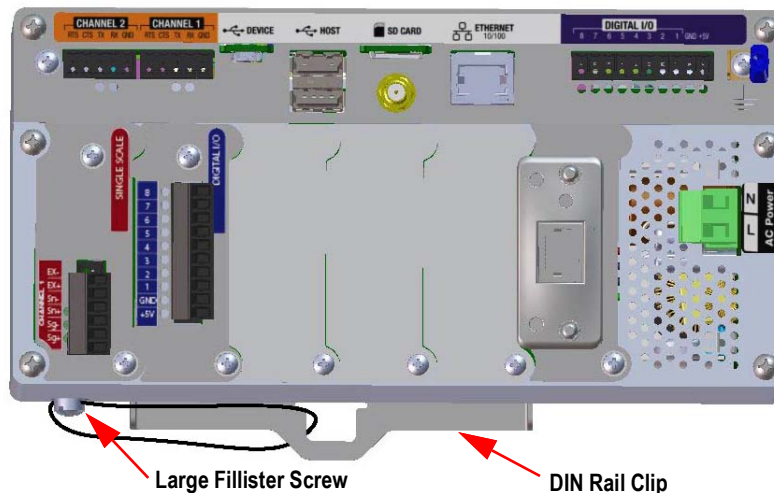

Figure 2-22. Seal the Setup Switch (Panel Mount Enclosure)

Use the following instructions to install option cards. There are two SPI communication buses for the six option card slots: one for slots 1, 2 and 3 and one for slots 4, 5 and 6. Communication is faster with less traffic on an SPI bus. For optimal performance, populate slots 1 and 4 first in order to keep cards on their own SPI bus.

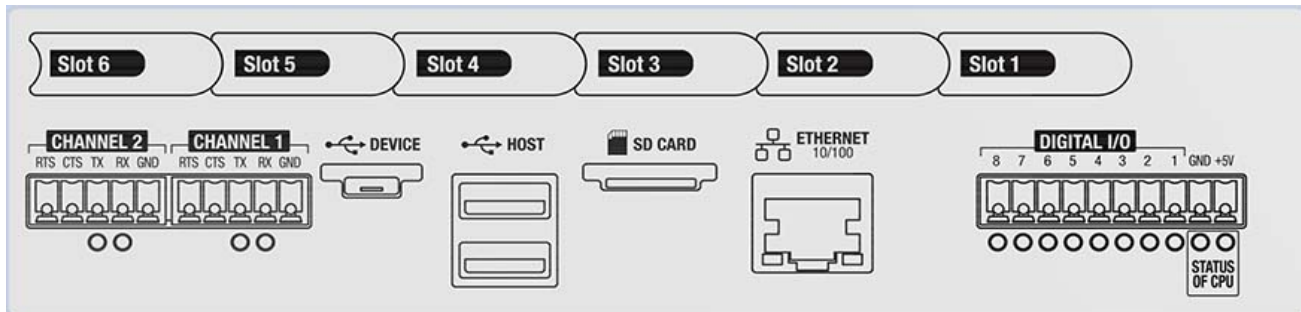

Figure 2-23. Label on Top of Controller Assembly

NOTE: Figure 2-24 illustrates label location.

WARNING: Always disconnect power before opening the indicator.

IMPORTANT: Use a wrist strap to ground yourself and protect components from electrostatic discharge (ESD) when working inside the indicator enclosure.

* Procedures requiring work inside the indicator must be performed by qualified service personnel only.

* In the wall and universal mounts, the supply cord serves as the power disconnect. The power receptacle to the indicator must be accessible for these models.

It is recommended to remove the controller assembly from the universal enclosure for easier installation of option cards. Recommended option card connection torque rating for most options cards is 2-4 in-lb (0.22-0.45 N-m).

Recommended connection torque rating for the relay card is 5 in-lb (0.56 N-m) 16-28 AWG.

1. Remove the hardware securing the slot cover plate.
2. Remove the slot cover plate.
3. Slide the option card into place.
4. Secure the card using the hardware which secure the slot cover plate.
5. Connect cables.

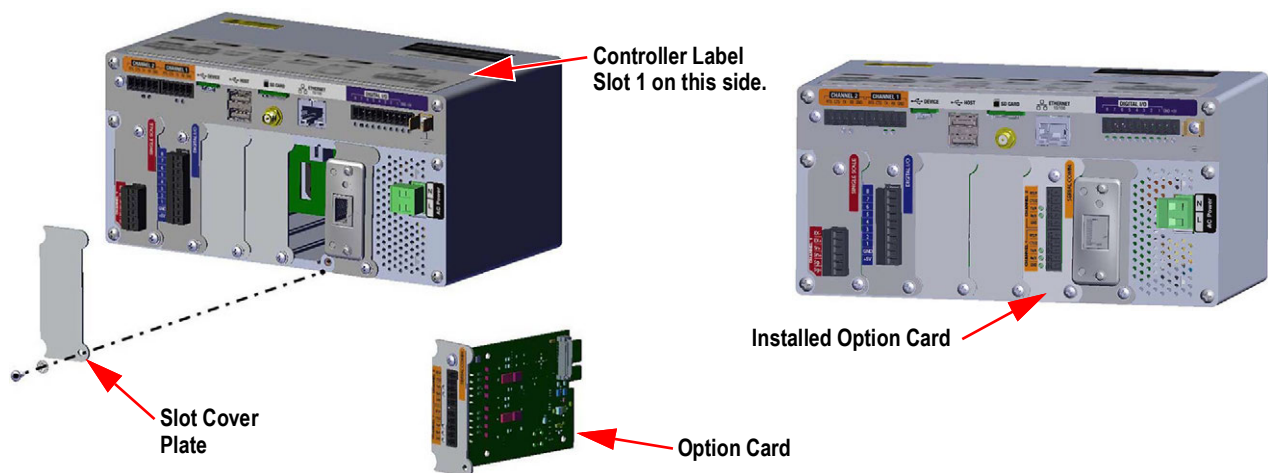

Figure 2-24. Option Card Installation

Seal the Scale Card

Once an option card has been put into place and cable connections have been made, a seal can be placed over the card and connections to restrict access and keep them from being removed.



Figure 2-25. Seal Option Card

1. Align the sealing bracket over the connectors on the option card.
2. Secure with two fillister screws.
3. Insert the lead wire seal through the holes in the sealing bracket and the fillister screws.

2.3 Cable Connections

The universal and wall enclosures provide cord grips for cabling into the indicator; one for the power cord and the rest are to accommodate interface cables. Install plugs in unused cord grips to prevent moisture from entering the enclosure. Secure wires after cabling is complete to avoid low voltage circuits contacting high voltage circuits.

IMPORTANT: If the indicator is on a network that has PoE capable Power Sourcing Equipment (PSE), the PSE must be IEEE 802.af or 802.at compliant. Any PSE that uses passive (always-on) technology will damage the Ethernet port, because it is not designed to act as an Ethernet PoE Powered Device.

2.3.1 Water/Dust Tight Cord Grips

The standard cord grip has a black bushing that clamps down on the cable. If cord grip does not run a cable, then add optional post plug to maintain IP seal.

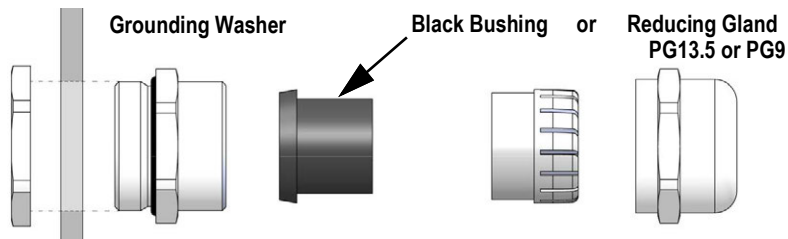

Figure 2-26. Cord Grip with Reducing Gland

Replace the bushing with a reducing gland to accommodate a smaller diameter cable. The reducing gland will allow the cord grip to maintain as much water/dust tightness as possible. Install the reducing gland in the top section of the cord grip in place of the bushing.

Cord Grip (PN)	Cord Grip Diameter	Reducing Gland (PN)	Reducing Gland Diameter
PG13.5 (169876)	0.264-0.472 in (6.7-12 mm)	PG13.5 (195006)	0.157-0.354 in (4-9 mm)
PG9 (169875)	0.157-0.314 in (4-8 mm)	PG9 (195007)	0.118-0.236 in (3-6 mm)

Table 2-2. Cord Grip and Reducing Gland Diameters

2.3.2 Shield Grounding Through Cord Grips

To ground cables to the chassis of the universal or wall enclosures, route the cable through one of the metal cord grips. Ensure the exposed shielding makes contact with the tabs of the grounding washer inside the cord grip. Grounding washers are included in the parts kit provided with the indicator.

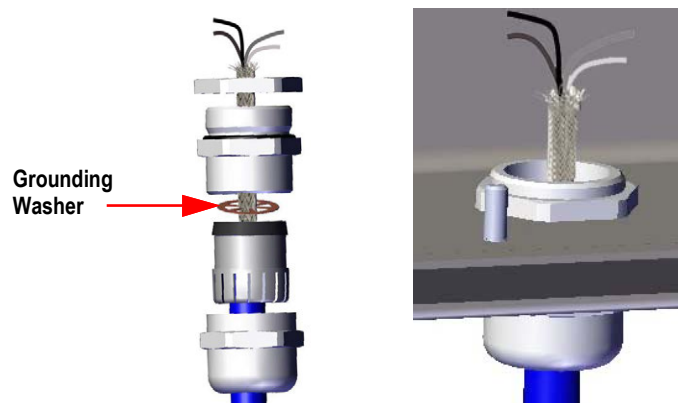

Figure 2-27. Universal and Wall Enclosure Grounding

IMPORTANT: All cables routed through the cord grips must be shield grounded against the enclosure. Ensure contact between the exposed shielding and the tabs of the grounding washer. If using foil shields, shield grounding with a clamp and ground stud as in Section 2.3.3 is the most effective grounding method.

2.3.3 Shield Grounding with Clamp and Ground Stud

For Universal Mount and Wall Mount indicators:

1. Use hardware provided in the parts kit to install shielding clamps on the grounding studs at the bottom of the enclosure.
2. Route cables through the cord grips and shielding clamps to determine the cable lengths required to reach the appropriate cable connectors.
3. Cut and fold shield wire and foil insulation as in Figure 2-28.
4. Tighten nut to secure.

For Panel Mount indicators, place the shield wire in a grounding clip on the controller assembly to ground load cell and interface cables to the enclosure and secure as above.

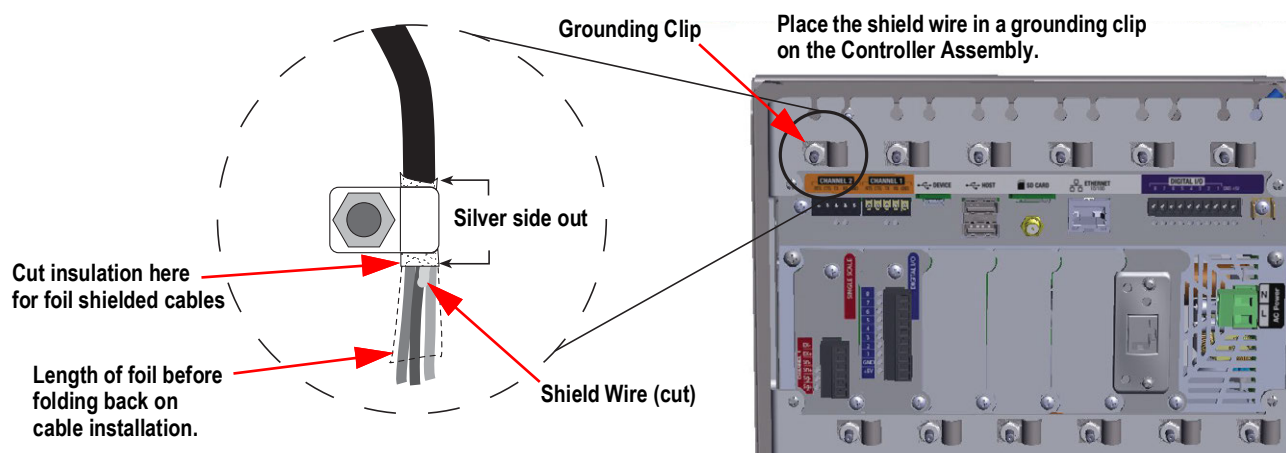

Figure 2-28. 1280 Ground Clamp and Stud Shown on Panel Mount

NOTE: The grounding stud from the power supply must be grounded to earth ground per national electrical code (NEC).

2.3.4 ESD Grounding for Touch Only Models

The 1280 ESD Grounding Kit (PN 194056) is included with all touch only models. Follow the grounding procedure to properly install the contents of the grounding kit and to avoid any ESD grounding issues.

Part No.	Description	Qty
17780	Ground Strap, 16 in Tinned Copper Braid	1
53075	Clamp, Ground Cable Shield	2
193810	Clamp, Ground Cable Shield Small	2
15139	Washer, Star Lock NO 10 Type A	7
14621	Nut, Keps 6-32NC Hex	1

Table 2-3. 1280 Grounding Kit Parts List

Grounding Procedure

1. Ensure the 1280 is powered down and disconnected from power source.
2. Attach ground strap to the backplate of the panel mount using one of the studs and nuts which hold the backplate in place. Order of reassembly must be star washer, ground strap, star washer and lastly the original nut.



NOTE: Torque the nuts which secure the backplate to 15 in-lb (1.7 N-m).

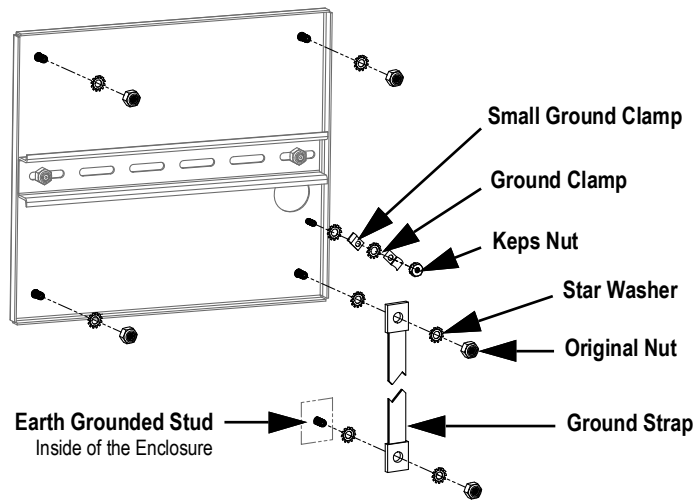

Figure 2-29. Backplate Shield Grounding

3. Secure the other end of the ground strap to an earth grounded stud inside of the enclosure with star washers on either side of the ground strap, see [Figure 2-29](#). Make sure there is an appropriate amount of slack in the grounding strap for opening and closing the enclosure door.
4. Replace the existing washers with star washers for the remaining three studs and nuts which hold the backplate in place.

5. Ground the display cable and the touchscreen cable to the backplate grounding stud using two ground clamps and the Keps nut. PN 193810 ground clamp has a smaller radius and must be used with the touchscreen cable.



NOTE: [Figure 2-30](#) is for illustration only and may not represent all panel mount applications. Grounding location and exact stud placement may vary.

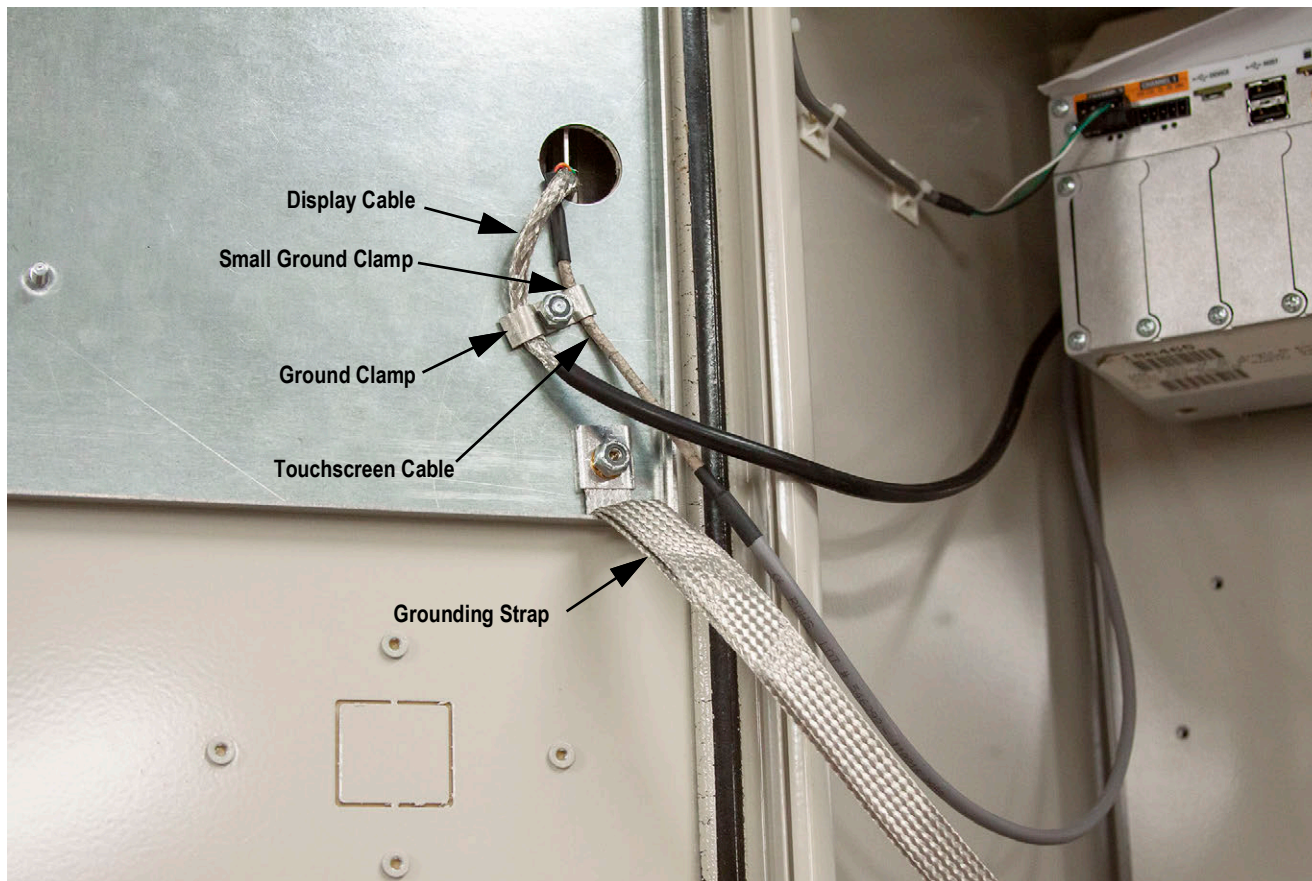

Figure 2-30. Panel Mount Shield Grounding



NOTE: Ensure the small ground clamp is installed first then install the ground clamp, see [Figure 2-29](#) on page 36.

6. Remove the 1280 controller box from the enclosure.
7. Remove the original ground clamp used on both the display and touchscreen cables, see [Figure 2-19](#) on page 31.
8. Ground the display cable and the touchscreen cable to the controller box using two ground clamps. PN 193810 ground clamp has a smaller radius and must be used with the touchscreen cable.

2.3.5 Load Cells

There are two generations of A/D scale cards. See the below table for identifying characteristics and sources of further information.

Card Generation	Channels	Card PN	Identifying Characteristics	Installation Addendum Number	Flash Instructions
First Generation	Single	164085	green circuit board, slide switch, one scale channel	164652	See the 1280 Technical Manual (PN 167659)
	Dual	164683	green circuit board, slide switch, two scale channels	164653	
Second Generation	Single	220026	blue circuit board, push button, one scale channel	220040	
	Dual	220027	blue circuit board, push button, two scale channels	220039	

Table 2-4. Scale Card Identification Information

Use the following instructions to attach the cable from a load cell or junction box to an installed A/D scale card channel.

1. Route the cables.
2. Wire the load cell cable from the load cell or junction box to the included 6 pin connector.
3. Plug the connector into the appropriate channel of the A/D scale card.

NOTE: Wire the load cell cable from the load cell or junction box to connector J1 and/or J2 if using a dual A/D scale card, see Table 2-5 for scale card pin assignments.

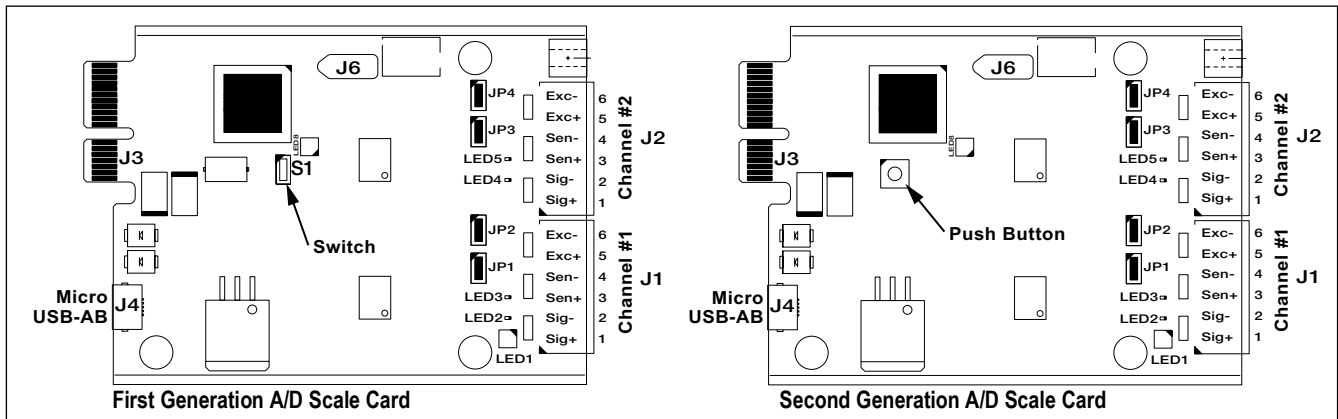

Figure 2-31. Single and Dual A/D Scale Cards

NOTE: If using a 6-wire load cell cable (with sense wires), remove jumpers JP1 and JP2 before reinstalling connector J1. On dual-channel A/D scale cards, remove jumpers JP3 and JP4 for connections to J2. For 4-wire installation, leave jumpers JP1 and JP2 on (or JP3 and JP4 depending on the channel).

Scale Card Connector Pin	Function
1	+SIG
2	-SIG
3	+SENSE
4	-SENSE
5	+EXC
6	-EXC

Table 2-5. Scale Card Pin Assignments

IMPORTANT: The A/D scale card must be removed from the controller prior to configuring the sense line jumpers.

NOTE: The hardware of J2 is not populated on a single A/D scale card.

2.3.6 Serial Communications

The two communication ports on the 1280 CPU board support full duplex RS-232, RS-422 or RS-485 communications at up to 115200 bps.

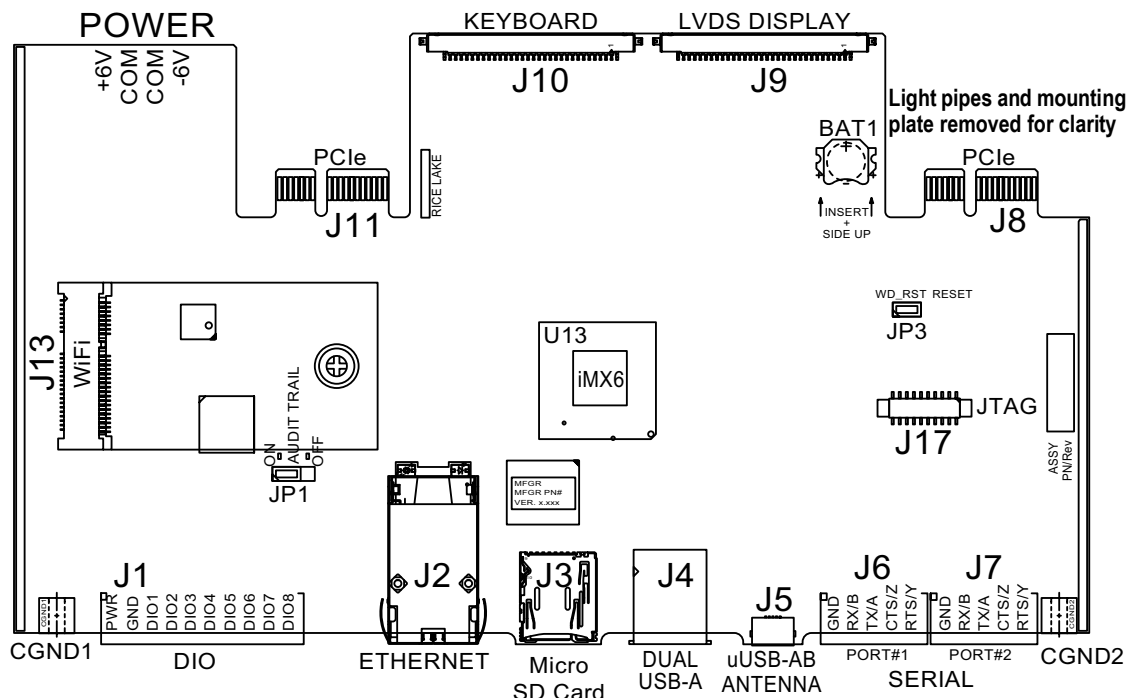

Figure 2-32. CPU Board (Top View)

Use the following instructions to attach serial communication cables.

1. Route cable through the cord grip.
2. Ground the shield wire.
3. Remove the screw holding the face plate.
4. Use clip to ground the front plate.
5. Wire the cables to the connector.
 - See [Table 2-6](#) for the serial protocol desired
6. Plug the wired connector into the intended serial port J6 (Port#1) or J7 (Port#2).

Connector	Pin	Signal	Port
J6	1	GND	1
	2	RS-232 RX/RS-485 B	
	3	RS-232 TX/RS-485 A	
	4	RS-232 CTS/RS-485 Z	
	5	RS-232 RTS/RS-485 Y	
J7	1	GND	2
	2	RS-232 RX/RS-485 B	
	3	RS-232 TX/RS-485 A	
	4	RS-232 CTS/RS-485 Z	
	5	RS-232 RTS/RS-485 Y	

Table 2-6. Serial Port Pin Assignments

Serial ports are configured using the **Serial** menu.

An optional dual-channel serial communications card, Kit PN 164685, is also available. Each serial option card provides two additional serial ports. Both ports on the option card can support RS-232, RS-422 or RS-485.

 **NOTE:** All wiring must conform to the NEC or local ordinances.

2.3.7 CPU Digital I/O Wiring

Digital I/O pins are configured using the Digital I/O menu.

An optional 24 I/O channel card (PN 164684) is also available. Each Digital I/O option card provides an additional 24 configurable I/O bits. Alternatively, a 4-channel Relay card (PN 164689) is also available.

Use the following instructions to wire to the CPU board DIO connector.

1. Route cable through the cord grip, see [Section 2.3.1 on page 34](#).
2. Ground the shield wire, see [Section 2.3.2 on page 35](#).
 - For a wall mount enclosure, route wires to a Relay Rack if equipped (skip [Step 3](#) and [Step 4](#))
3. Remove the screw holding the face plate.
4. Use clip to ground the front plate.
5. Wire the cables to the connector.
6. Plug the connector into J1 on the board.

Connector	Pin	Signal
J1	1	+5 VDC
	2	GND
	3	DIO 1
	4	DIO 2
	5	DIO 3
	6	DIO 4
	7	DIO 5
	8	DIO 6
	9	DIO 7
	10	DIO 8

Table 2-7. CPU Digital I/O Pin Assignments

2.4 Wiring Schematics

2.4.1 Key Pad Model

For proper wiring of the key pad model, see [Figure 2-33](#).

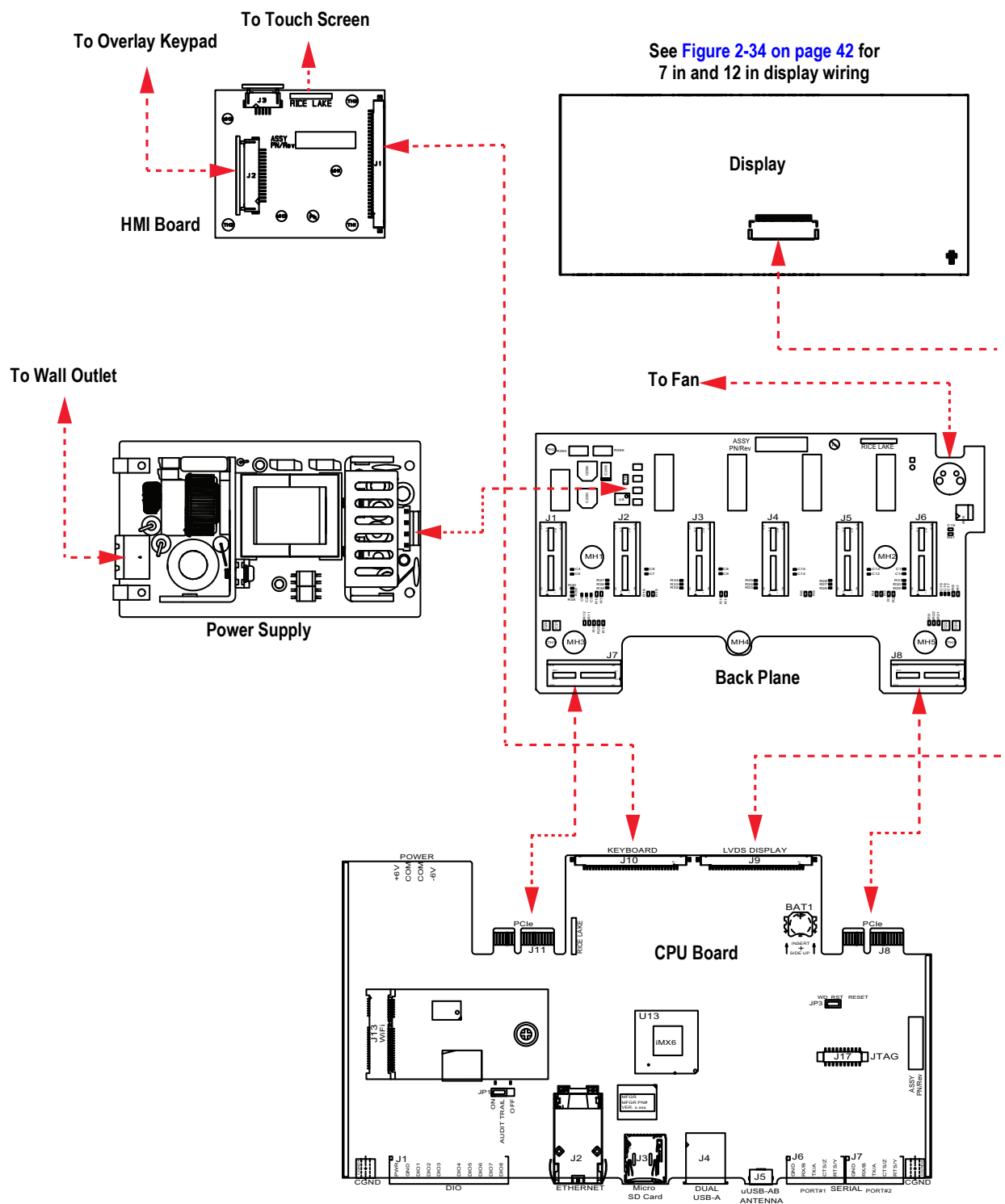

Figure 2-33. Wiring Diagram

2.4.2 Touch Screen Only (Virtual Keypad)

To assemble the touchscreen (virtual keypad), see [Figure 2-34](#).

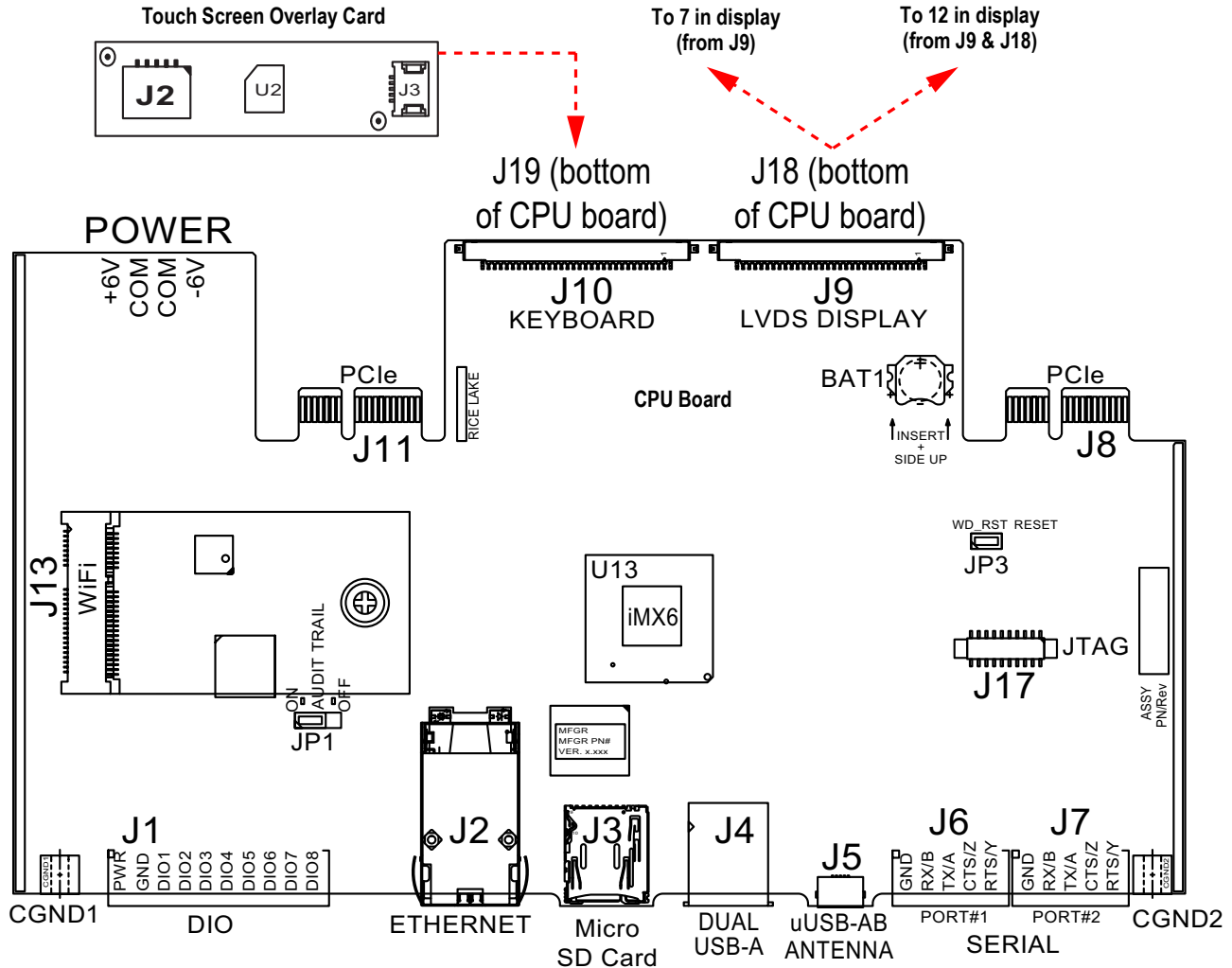

Figure 2-34. Panel Mounts – 7 Inch and 12 Inch Touch-Only

The HMI cable (PN 180002) plugs from J2 on the overlay card to J19 on bottom of CPU board.

Connect CPU to display cable (PN 164995 or 164970) from J9 to 7 in display.

Connect CPU to display cable (PN 180001) from J9 and J18 on the bottom of CPU board to 12 in display.



NOTE: Additional cable lengths are available.

2.5 Configuration Methods

The indicator can be configured using:

- Front panel keys to navigate through a series of configuration menus
- Revolution configuration utility
- EDP command configuration



NOTE: Some configuration parameters, such as those used to configure the display and widgets, cannot be accessed through the configuration menus. Revolution provides the most complete and efficient configuration interface.

2.6 CPU Board Replacement

WARNING: Always disconnect power before opening the indicator.

IMPORTANT: Use a wrist strap to ground yourself and protect components from electrostatic discharge (ESD) when working inside the indicator enclosure.

* Procedures requiring work inside the indicator must be performed by qualified service personnel only.

* In the wall and universal mounts, the supply cord serves as the power disconnect. The power receptacle to the indicator must be accessible for these models.

1. Disconnect all cables from the controller assembly.

IMPORTANT: Handle with care. The boards are fragile.

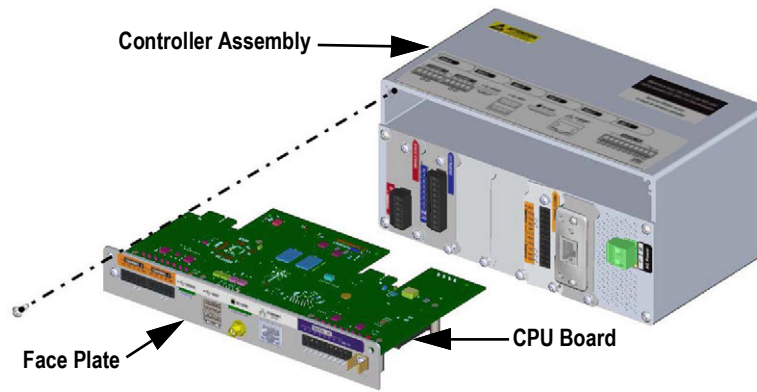

Figure 2-35. Remove CPU Board

2. Remove the two screws securing the face plate to the controller assembly.
3. Remove the face plate and board assembly from the controller.

IMPORTANT: Only remove the CPU board from the face plate if it is being replaced.

2.6.1 Remove CPU Board from Face Plate

1. Remove the nut securing the antenna.
2. Remove the two screws securing the CPU board to the face plate.

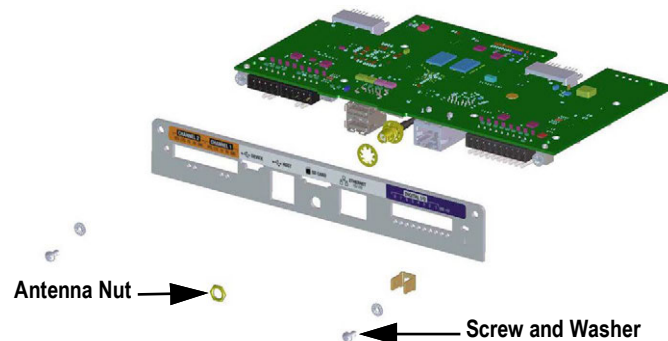

Figure 2-36. CPU Board and Face Plate

3. Separate the face plate and the CPU board.

Reverse procedure for reassembly.

NOTE: Recommended CPU board connection torque ratings are 2-4 in-lb (0.22-0.25 N-m).

2.7 Rechargeable Coin-Cell Battery Replacement

The 1280 Series Indicator uses a rechargeable 3V lithium coin-cell battery as backup power to maintain the time and date when the indicator is disconnected from power. Replace the coin-cell battery if it fails to maintain charge.

1. Remove the CPU Board as described in [Section 2.6 on page 43](#).
2. Use a non-conductive tool to gently push the battery through the two access holes and out of the battery pocket.

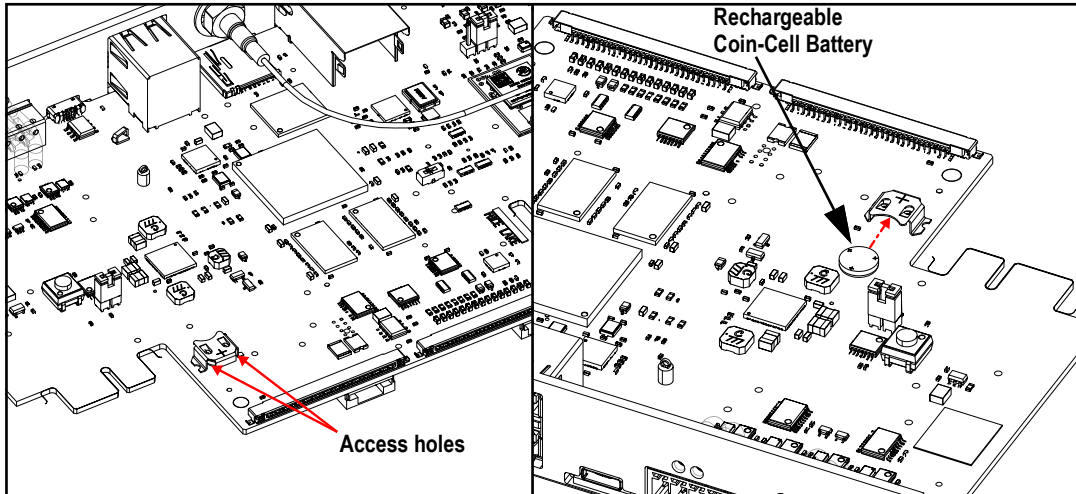

Figure 2-37. Coin-cell Battery Removal (left) and Replacement (right)

3. Fully slide the replacement coin-cell battery into the pocket using the same non-conductive tool.



IMPORTANT: Ensure the positive terminal of the battery is facing up. Incorrectly matching the battery terminals to the circuit can result in permanent damage to the device.

2.8 Power Supply Replacement

WARNING: Always disconnect power before opening the indicator.

IMPORTANT: Use a wrist strap to ground yourself and protect components from electrostatic discharge (ESD) when working inside the indicator enclosure.

* Procedures requiring work inside the indicator must be performed by qualified service personnel only.

* In the wall and universal mounts, the supply cord serves as the power disconnect. The power receptacle to the indicator must be accessible for these models.

Use the following instructions to replace the power supply.

1. Disconnect all cables from the controller assembly.

IMPORTANT: Handle with care. The boards are fragile.

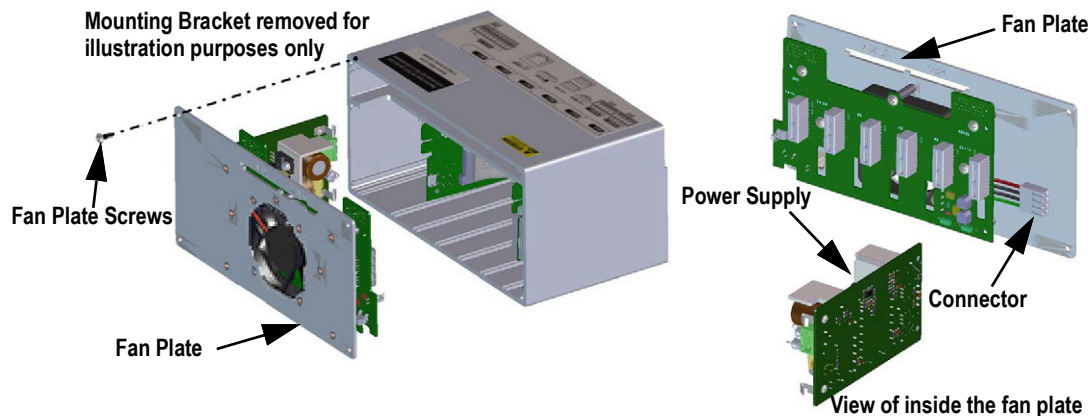

Figure 2-38. Remove Power Supply

2. Remove the four screws from the fan plate.
3. Carefully pull the fan plate/power supply assembly from the enclosure, supporting the power supply as it is removed. It is only connected to the fan plate assembly by a connector.
4. Disconnect the power supply from the connector.

Reverse procedure for reassembly.

NOTE: Torque connector screw terminals which secure AC and DC power to 5 in-lb (0.5 - 0.6 N-m).

2.9 Replace Fan Plate and Back Plane

WARNING: Always disconnect power before opening the indicator.

IMPORTANT: Use a wrist strap to ground yourself and protect components from electrostatic discharge (ESD) when working inside the indicator enclosure.

- Procedures requiring work inside the indicator must be performed by qualified service personnel only.
- In the wall and universal mounts, the supply cord serves as the power disconnect. The power receptacle to the indicator must be accessible for these models.

IMPORTANT: If replacing CPU boards, a new fan plate is also required.

Use the following instructions to replace the fan plate and back plane.

1. Disconnect the power supply, see [Section 2.7 on page 44](#).
2. Loosen the five screws securing the back plate board assembly and remove the board.

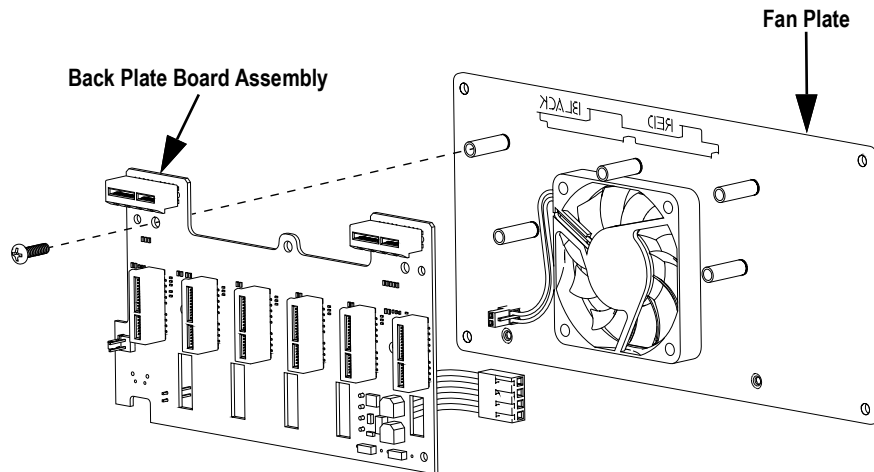

Figure 2-39. Remove Back Plate Board Assembly

NOTE: Orientation of the fan prior to removal. It is important the fan is reinstalled in the correct orientation.

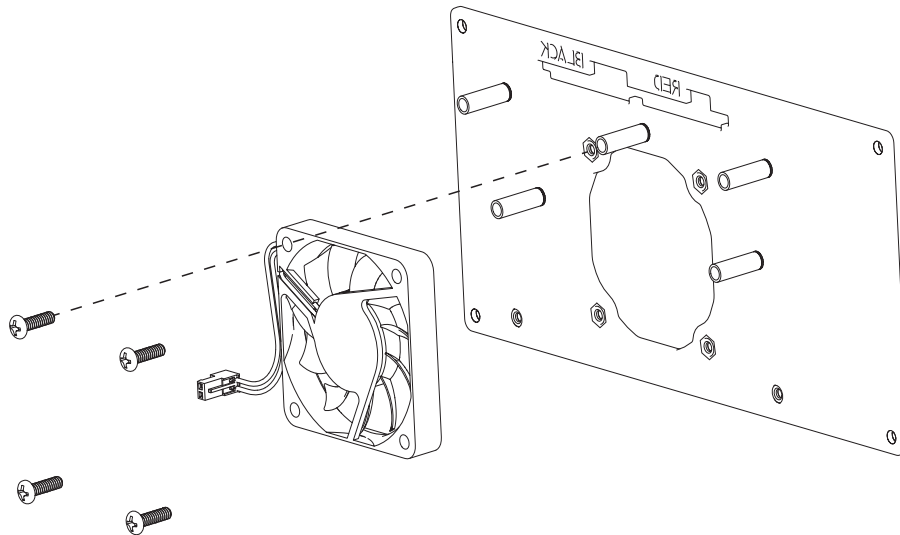

Figure 2-40. Remove Fan

3. Loosen the four screws securing the fan to the fan plate and remove the fan.

Reverse this procedure for reassembly.

2.10 Replacement Parts

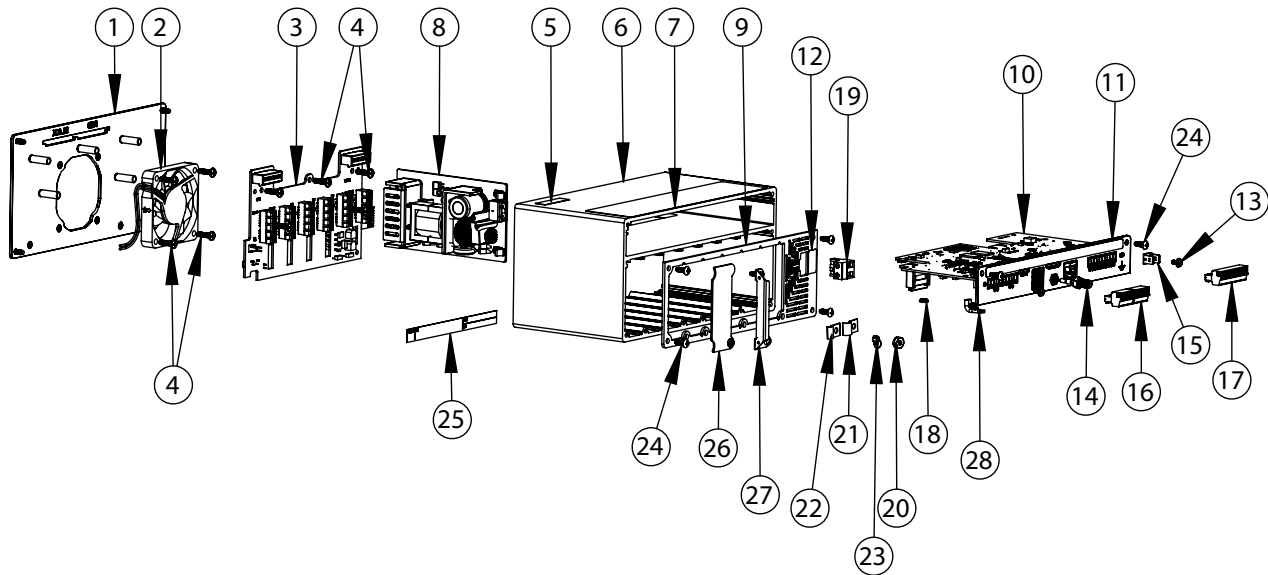

Figure 2-41. Controller Assembly Repair Parts

Item No.	Part No.	Description
1	169350	Fan Mount Plate Assembly
2	166745	Fan Assembly, 60 mm x 10 mm DC with 2 Position .100 Connector
3	160758	Board Assembly, 1280 Backplane 6 Channel Option Card Backplane
4	44341	Screw, MACH 6-32 NC x 1/2 in Ig Phillips Head
5	168591	Label, ESD Warning
6	169159	Extrusion Assembly
7	167190	Label, 1280 Controller Identification of Connections and Slots
8	202512	AC Power Supply
	202514	DC/DC Power Supply
9	193984	Face Plate, Bonded Ground 1280 Controller
10	179992	CPU Board Assembly with Fan Plate
11	193985	Face Plate, CPU PCB
12	167476	Label, AC Power
	167477	Label, DC Power
13	14822	Screw, Mach 4-40NC x 1/4 in Phillips Pan Head Internal Tooth Lock Washer Steel
14	163336	Cable, Antenna Bulkhead
15	168830	Terminal, Tab 1/4 in Push
16	153882	Conn, 5 Pos Screw Terminal Pluggable 3.5 mm
17	164918	Conn, 10 Pos Screw Terminal Pluggable 3.5 mm
18	170492	Battery, Rechargeable ML 3V, 5mAh 6.8mm x 2.2mm Coin Manganese Lithium, Ion
19	162677	Connector for AC, 2 Pos Screw Terminal Pluggable 7.62 mm
	15888	Connector for DC, 3 Pos Screw Terminal Pluggable 5.08 mm
20	14621	Nut, Kep 6-32 NC Hex External Tooth Lockable
21	67550	Clamp, Ground Shield, Radius 0.125 in
22	53075	Clamp, Ground Shield, Radius 0.078 in
24	163327	Screw, Mach 6-32NC x 3/8 in Phillips Head
25	94422	Label, Capacity
26	163408	Blank Plate, Empty Option Card Slot Cover
27	165927	Clip, Locking Load Cell (Kit PN 166957)
-	219129	Label, MRMI Capacity

Table 2-8. Controller Assembly Repair Parts List

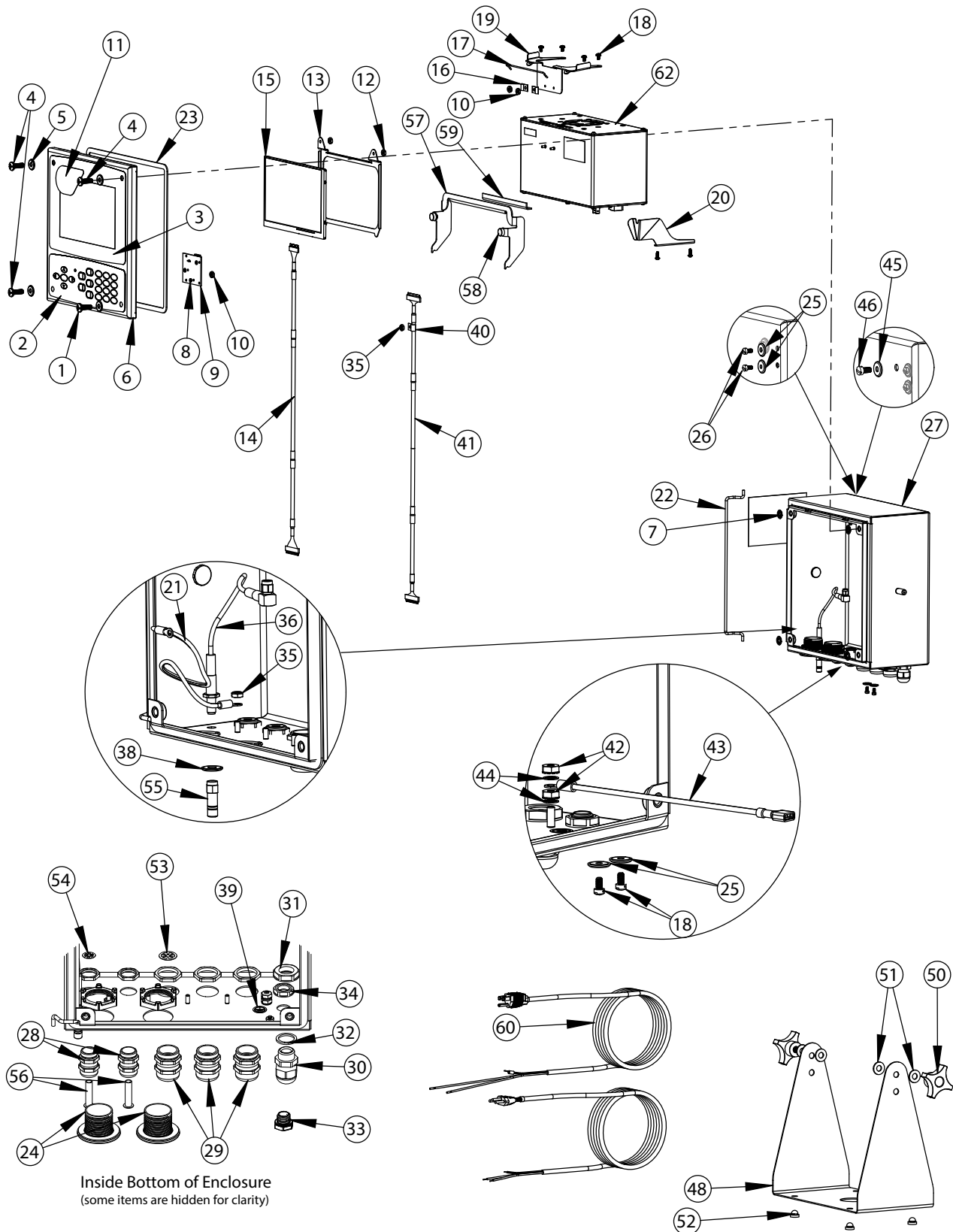

Figure 2-42. Universal Repair Parts

Item No.	Part No.	Description	Item No.	Part No.	Description
	169926	Door Assembly, Universal (inc. 1-11)	30	15626	Cord Grip, Black PG 9
1	165970	Screw, 1/4-20NC x 3/4 in Drilled Head	31	15627	Locknut, Black PCN9
2	161731	Overlay, Keypad	32	30375	Seal Ring, Nylon PG9
3	161730	Overlay, Touchscreen	33	88733	Vent, Breather Sealed
4	166631	Screw, 1/4-20NC x 3/4 in	34	88734	Nut, Breather Vent
5	182281	Washer, Washer Cup 1/4 in	35	58248	Nut, Lock 6-32 NC Hex Nylon
	182246	Washer Gasket, 1/4 in	36	166240	Cable, Antenna Extension
6	169450	Front Door, Universal	38	182281	Washer, Washer Cup 1/4 in
7	166653	Retainer, Push Nut Bolt 1/4 in		182246	Washer Gasket, 1/4 in
8	69898	Washer, Nylon #4 ID = 0.112	39	16892	Label, Ground
9	160759	Board Assembly, HMI Keypad/Touch Interface			Other Items (inc. 40-48)
10	159280	Nut, Lock 4-40 SST	40	67550	Clamp, Ground Cable Shield
11	172840	Decal, 1280 Start Screen	41	166693	Cable, CPU to HMI 18 in
	160383	Universal Display, 500 NITS (inc. 12-15)	42	14626	Nut, Kep 8-32 NC Hex
	160385	Universal Display, 1000 NITS (inc. 12-15)	43	15601	Wire, Ground 9 Inch #8
12	58248	Nut, Lock 6-32 NC HEX Nylon	44	15134	Washer, Lock NO 8 Type A
13	162272	Mounting Bracket Display (500 Nit)	45	46381	Washer, Bonded Sealing SST
	162271	Mounting Bracket Display (1000 Nit)	46	183662	Screw, 10-32 x 1/2, Drilled Hex Head
14	163467	Cable, CPU to Display (500 Nit) 18 in, Black	48	161620	Stand, Tilt Surface Mount
	163444	Cable, CPU to Display (1000 Nit) 18 in, Black	-	219129	Label, MRMI Capacity
15	163400	Display, (500 NITS) 7 in LCD		163785	Universal Parts Kit (inc. 50-56)
	163399	Display, (1000 NITS) 7 in LCD	50	164064	Hand Knob, 4-Arm 5/16-18
	169461	Universal Controller Bracket (inc. 16-20)	51	79024	Washer, Plain 5/16 in Nylon
16	53075	Clamp, Ground Cable Shield	52	42149	Bumper, Rubber Grommet
17	168545	Bail, Controller Retainer Wire	53	169879	Grounding Clip, PG 13.5
18	14839	Screw, Machine 6-32NC x 1/4 in	54	169878	Grounding Clip, PG 9
19	169462	Bracket Assembly, Controller	55	206703	Antenna, RP-SMA
20	168937	Snap Tap, Controller Support	56	19538	Post Plug, PG 9
	169927	Universal Cabinet Assembly (inc. 21-39)		172220	Post Plug, PG 13.5
21	40672	Wire Assembly, Ground 9 in		195007	Reducing Gland PG 13.5
22	169410	Hinge Link		195006	Reducing Gland PG 9
23	160379	Gasket, Front Panel		172859	Bracket Assembly (inc. 57-59)
24	124695	Panel Plug, Round Solid	57	172856	Bracket, Controller Shipping Support
25	167537	Washer, Sealing BarTite #6	58	15149	Foot, Rubber Bumper
26	183663	Screw, 6-32 x 1/4, Drilled Hex Head	59	172872	Pad, Foam
27	169452	Enclosure Shell Assembly, Universal	60	165108	Cord, US Power
28	169875	Cord Grip, PG 9 With Nut		165109	Cord, European Power
29	169876	Cord Grip, PG 13.5 With Nut	62	199157	Controller Assembly (Figure 2-41 on page 47)

Table 2-9. Universal Parts List

Cover exploded for clarity

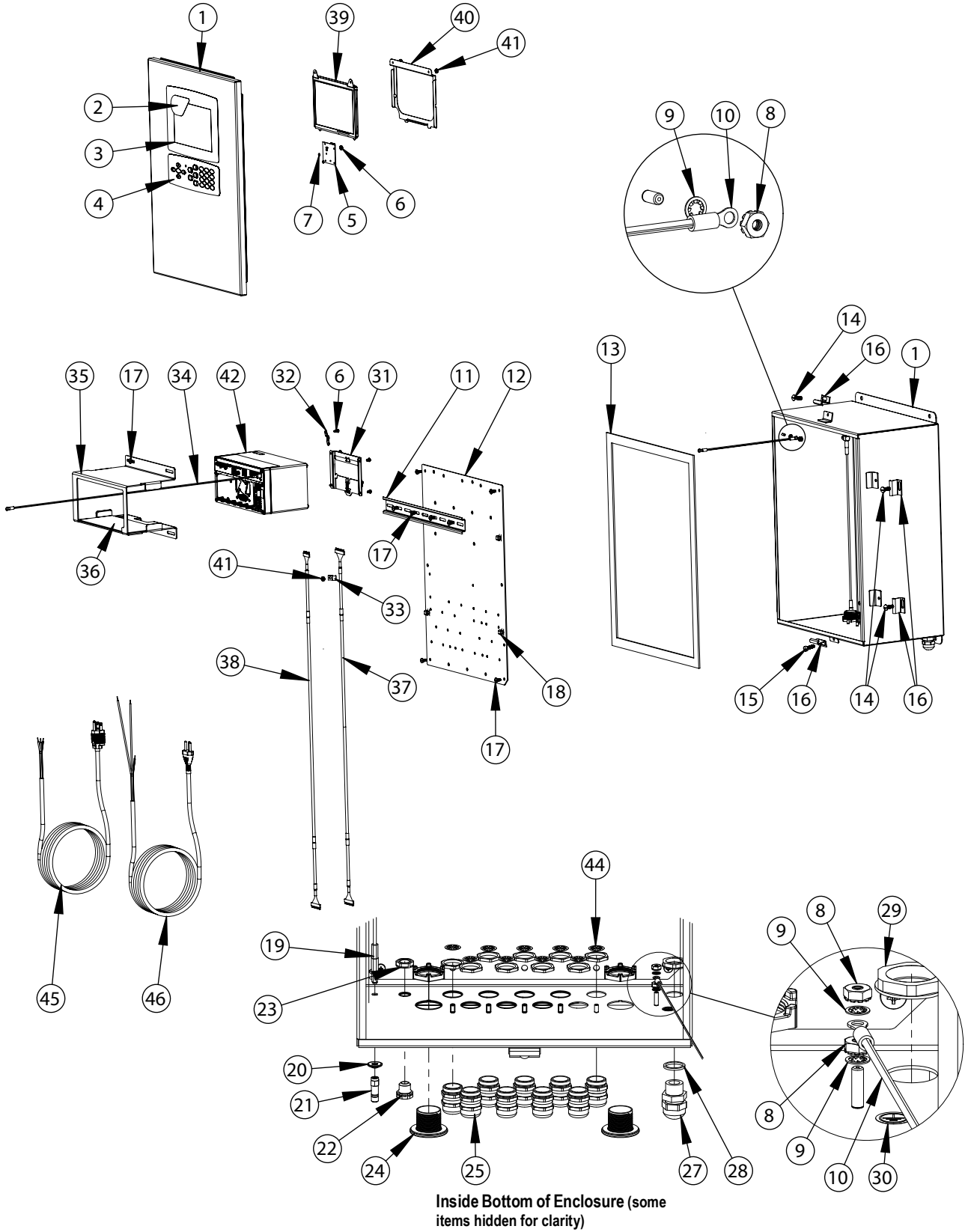

Figure 2-43. Wall Mount Repair Parts

Item No.	Part No.	Description	Item No.	Part No.	Description
	164680	1280 Indicator Sub-Assembly (includes 1-34)	30	16892	Label, Ground Protective
1	161416	Enclosure Assembly	31	166838	Bracket Assembly, DIN Rail
2	172840	Decal, 1280 Start Screen	32	53075	Ground Strap
3	164120	Overlay, Touchscreen	33	67550	Clamp, Ground Cable Shield
4	164121	Overlay, Keypad	34	202490	Wire, Ground 24 in #8 Eye
5	160759	Board Assembly, Keypad/Touch Interface		173052	Bracket Assembly, 1280 (Includes 35-36)
6	159280	Nut, Lock 4-40 SST	35	172860	Bracket, 1280 Wall Mount
7	69898	Washer, Nylon #4 ID 0.112 in	36	173053	Gasket, 1280 Wall Mount
8	14626	Nut, Kep 8-32NC Hex	37	166694	Cable, CPU to HMI 30 in
9	15134	Washer, Lock No 8 Type A		166725	Universal Display, 500 Nit (Includes 38-41)
10	202490	Wire Assembly, Ground 9 in		166726	Universal Display, 1000 Nit (Includes 38-41)
11	179418	Rail, DIN 12.75 in Length	38	164995	Cable, CPU to Display (500 Nit) 30 in
12	164900	Back Plane Panel		164970	Cable, CPU to Display (1000 Nit) 30 in
13	68724	Gasket, Front Cover	39	163400	Display, (500 Nit) 7 in LCD
14	71447	Screw, Mach 1/4 - 28NF x 3/4 in		163399	Display, (1000 Nit) 7 in LCD
15	71455	Screw, Mach 1/4 - 28NF x 3/4 in Drilled	40	162272	Mounting Bracket (500 Nit)
16	71739	Clip, Clinching Enclosure		162271	Mounting Bracket (1000 Nit)
17	14875	Screw, MACH 10-32NF x 3/8 in	41	58248	Nut, Lock 6-32NC Hex Nylon
18	80590	Mount, Cable tie Arrowhead	42	199157	Controller Assembly (Figure 2-41 on page 47)
19	166241	Cable, Antenna Extension		163787	Parts Kit 1280 Wall Mount (Inc. items 44)
20	182246	Gasket, Washer Seal 1/4-Inch	43	169879	Ground Clip, PG 13.5
	182281	Washer Shell, 1/4 Inch Sealing		169878	Ground Clip, PG 9
22	88733	Vent, Breather Sealed		172220	Post Plug, PG 13.5
23	88734	Nut, Breather Vent		19568	Post Plug PG 9
24	124695	Panel Plug, Round Solid		195007	Reducing Gland, PG 13.5
25	169876	Cord Grip, PG13.5 With Nut		195006	Reducing Gland, PG 9
	169875	Cord Grip, PG 9 With Nut	44	206703	Antenna, RP-SMA
27	68600	Cord Grip, PG11	45	165111	Cord, US Power
28	68599	Seal Ring, Nylon PG 11	46	165112	Cord, European Power
29	68601	Nut, PG 11, Power Cord Cable	-	219129	Label, MRMI Capacity

Table 2-10. Wall Mount Repair Parts List

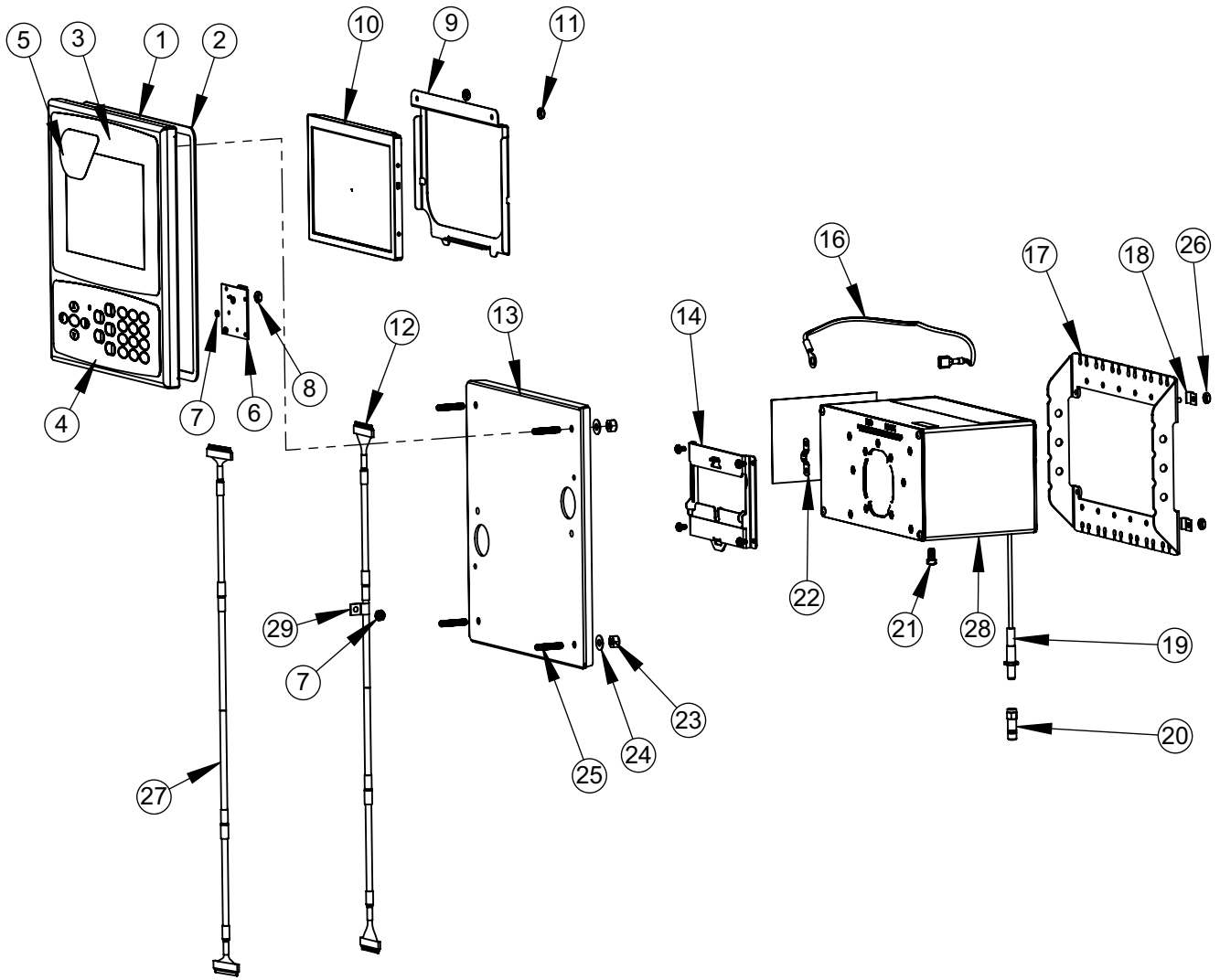

Figure 2-44. 7 Inch Panel Mount Repair Parts

Item No.	Part No.	Description
	169930	Enclosure Face Plate Assembly (Inc 1-7)
1	169929	Face Panel
2	160379	Gasket, Front Panel
3	164120	Overlay, Touchscreen
4	164121	Overlay, Keypad
5	172840	Decal, 1280 Start Screen
6	160759	Board Assembly, Keypad/Touch Interface
7	69898	Washer, Nylon #4 ID = 0.112
8	159280	Nut, Lock Nylon Insert
	166725	500 NIT Display (Inc 9-12)
	166726	1000 NIT Display (Inc 9-12)
9	162272	Mounting Bracket Display (500 Nit)
	162271	Mounting Bracket Display (1000 Nit)
10	163400	Display, (500 Nit) 7 in LCD
	163399	Display, (1000 Nit) 7 in LCD
11	58248	Nut, Lock 6-32NC Hex Nylon
12	164995	Cable, CPU to Display (500 Nit) 30 in
	164970	Cable, CPU to Display (1000 Nit) 30 in
13	186782	Mounting Plate Assembly
14	166838	Bracket Assembly, DIN Rail

Item No.	Part No.	Description
	163786	Parts Kit, Panel (Inc. 16-25 and all NS)
16	202845	Wire, 9 in Ground, 1/4 in Eye
17	169023	Ground Bus Bar
18	53075	Clamp, Ground Cable Shield
19	166241	Cable, Antenna Extension
20	206703	Antenna, RP-SMA
21	14877	Screw, Fillister 10-32NF x 3/8 in
22	168629	Ground Strap, 1280 CPU
23	14630	Nut, Lock 10-32NF Hex
24	22062	Washer, Plain No 10 Type A
25	168877	Screw, Set #10-32 x 1 in
26	14621	Nut, Kep 6-32NX Hex
NS	15130	Washer, Lock No 6 Type A
NS	158207	Screw, Mach 6-32 x 1/4 in Fillister
27	166694	Cable, CPU to HMI 30 in
28	199157	Controller Assembly (Figure 2-41 on page 47)
29	67550	Clamp, Ground Cable Shield
NS	14839	Screw, Mach 6-32NC x 1/4 in
-	219129	Label, MRMI Capacity

Table 2-11. 7 Inch Panel Enclosure Repair Parts List



NOTE: If controller is not connected to the panel, ground per NEC.

Part No.	Description
14621	Nut, Kep 6-32NC Hex External Tooth Lockwasher
14630	Nut, Lock 10-32NF Hex Nylon Insert Steel
14877	Screw, MACH 10-32NF x 3/8 Slotted Drilled Fillister
15130	Washer, Lock NO 6 Type A Internal Tooth Steel
15139	Washer, Lock NO 10 Type A External Tooth Steel
158207	Screw, Mach 6-32 x 1/4 Slotted Drilled Fillister
166241	Cable, Antenna Extension 30 Inch
206703	Antenna, RP-SMA 2.4, GHz 2dBi, Whip, Tilt, SMA
168629	Ground Strap, 1280 CPU 1/4 inch Eye to Spade

Part No.	Description
202845	Wire Assembly, Ground 9 1/4 inch Eye to Spade
168877	Screw, Set #10-32NF x 1 Hex Socket Head
169023	Ground Bus Bar
17780	Ground Strap, 16 in Tinned Copper Braid
182246	Gasket, Washer Seal 1/4-Inch Fasteners
182281	Washer Shell, 1/4 in Sealing
193810	Ground Cable Clamp Small 0.08
53075	Clamp, Ground Cable Shield 0.078
67550	Clamp, Ground Cable Shield 0.125

Table 2-12. Panel Mount Parts Kit (163786) Parts List

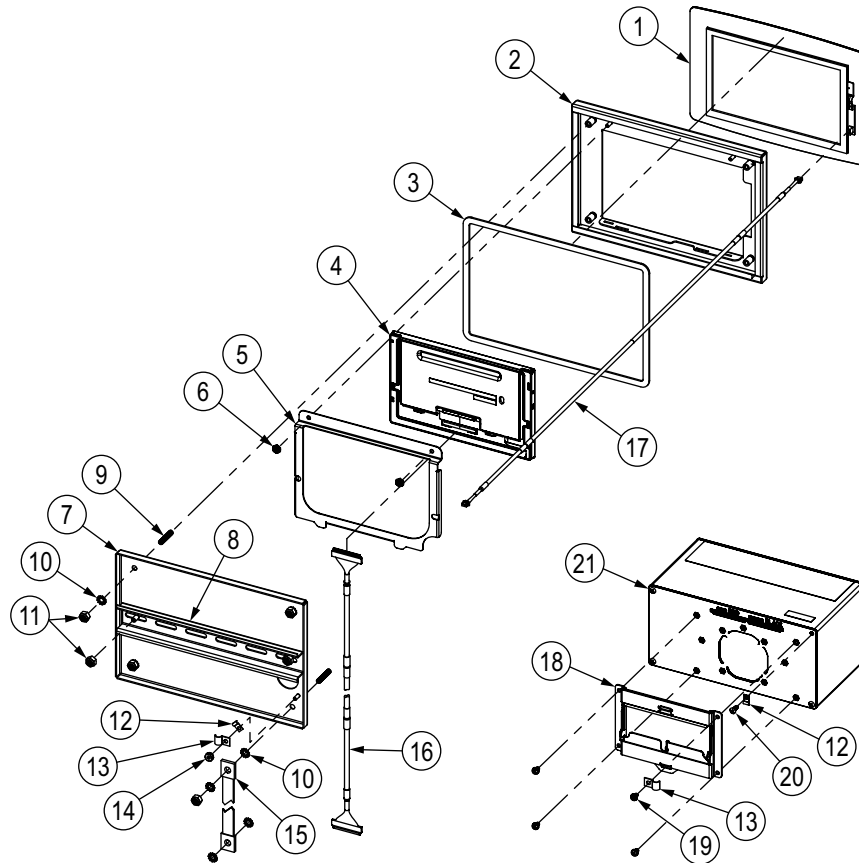

Figure 2-45. 7 Inch Touch-Only Panel Mount Repair Parts

Item No.	Part No.	Description
1	178498	Touchscreen Overlay, 7-Inch 1280 Touch Only
2	176129	Front Panel, 7-Inch 1280 Touch Only
3	176403	Gasket, 7-Inch
4	163400	Display Board, 500 NIT
	163399	Display Board, 1000 NIT
5	162272	Bracket, Display Mount 500 NIT
	162271	Bracket, Display Mount 1000 NIT
6	58248	Lock Nut, 6-32NC Nylon Insert Zinc Plated
7	176371	Mounting Plate Assembly,
8	181660	DIN Rail, 35mm x 15mm (8.5-Inch Length)
9	168877	Set Screw, 10-32NF x 1 Hex Socket Head Cup Point 18-8 SST
10	15139	Washer, Lock No 10 Type A External Tooth Steel Zinc Plated
11	14630	Lock Nut, 10-32NF Hex Nylon Insert Steel Zinc Plated
12	193810	Clamp, Small Ground Cable Shield Radius 0.08 in
13	67550	Clamp, Ground Cable Shield Radius 0.125 in
14	14621	Nut, KEP 6-32 Hex External Tooth Lockwasher Steel Zinc Plated
15	17780	Ground Strap, 16-Inch Tinned Copper Braid
16	164995	Cable, Controller to 500 NIT Display
	164970	Cable, 1280 Controller to 1000 NIT Display
17	180002	Cable, CPU to Touchscreen 30 Inches
18	166838	DIN Rail Mount Assembly, 1280 Controller
19	14839	Screw, Mach 6-32NC x 1/4 SEMS Steel Zinc Plated
20	163327	Screw, Mach 6-32NC x 3/8 Thread Rolling Phillips Pan Head Zinc Plated
21	199157	1280 Controller Assembly (Figure 2-41 on page 47)
-	219129	Label, MRMI Capacity

Table 2-13. 7 Inch Touch-Only Panel Mount Repair Parts List

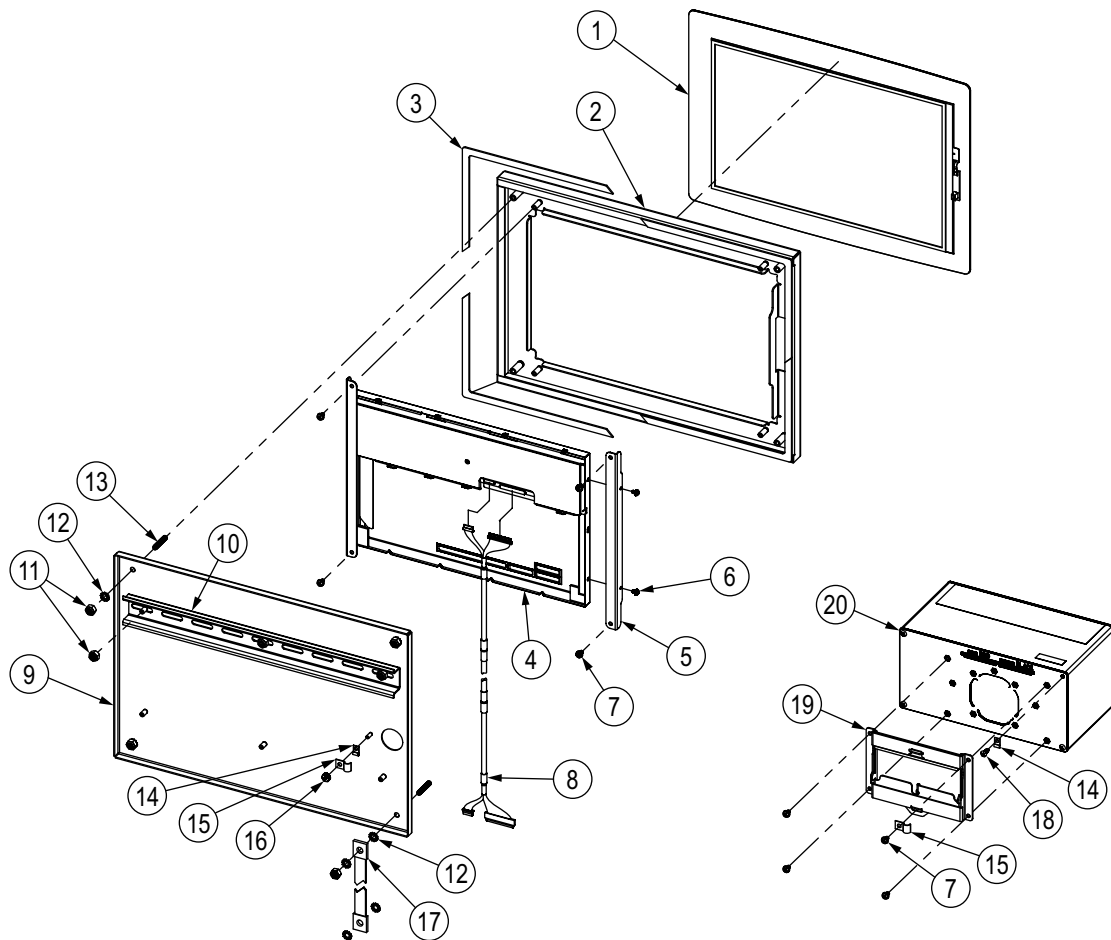

Figure 2-46. 12 Inch Touch-Only Panel Mount Repair Parts

Item No.	Part No.	Description
1	176126	Touchscreen Overlay, 12-Inch
2	176127	Front Panel Assembly, 12-Inch
3	176404	Gasket, 12-Inch Display Panel Mount
4	177396	Display Module, 12-Inch 1500 NIT
5	176242	Bracket, 12-Inch Display Mount
6	157209	Screw, Mach M3-0.5x5mm Pan Head with External Lockwasher SST
7	14839	Screw, Mach 6-32NC x 1/4 SEMS Steel Zinc Plated
8	180001	Cable, 1280 Controller to 12-Inch Display (insulated tape used to secure connection)
9	176372	Mounting Plate Assembly
10	179418	DIN Rail, 35mm x 15mm (12.75 Length)
11	14630	Lock Nut, 10-32NF Hex Nylon Insert Steel Zinc Plated
12	15139	Washer, Lock No 10 Type A External Tooth Steel Zinc Plated
13	168877	Set Screw, 10-32NF x 1 Hex Socket Head Cup Point 18-8 SST
14	193810	Clamp, Small Ground Cable Shield Radius 0.08 inch
15	67550	Clamp, Ground Cable Shield Radius 0.125 inch
16	14621	Nut, KEP 6-32 Hex External Tooth Lockwasher Steel Zinc Plated
17	17780	Ground Strap, 16 inch Tinned Copper Braid
18	163327	Screw, Mach 6-32NC x 3/8 Thread Rolling Phillips Pan Head Zinc Plated
19	166838	DIN Rail Mount Assembly, 1280 Controller
20	199157	1280 Controller Assembly (Figure 2-41 on page 47)
-	219129	Label, MRMI Capacity

Table 2-14. 12 Inch Touch-Only Panel Mount Repair Parts List

2.11 Label Legend

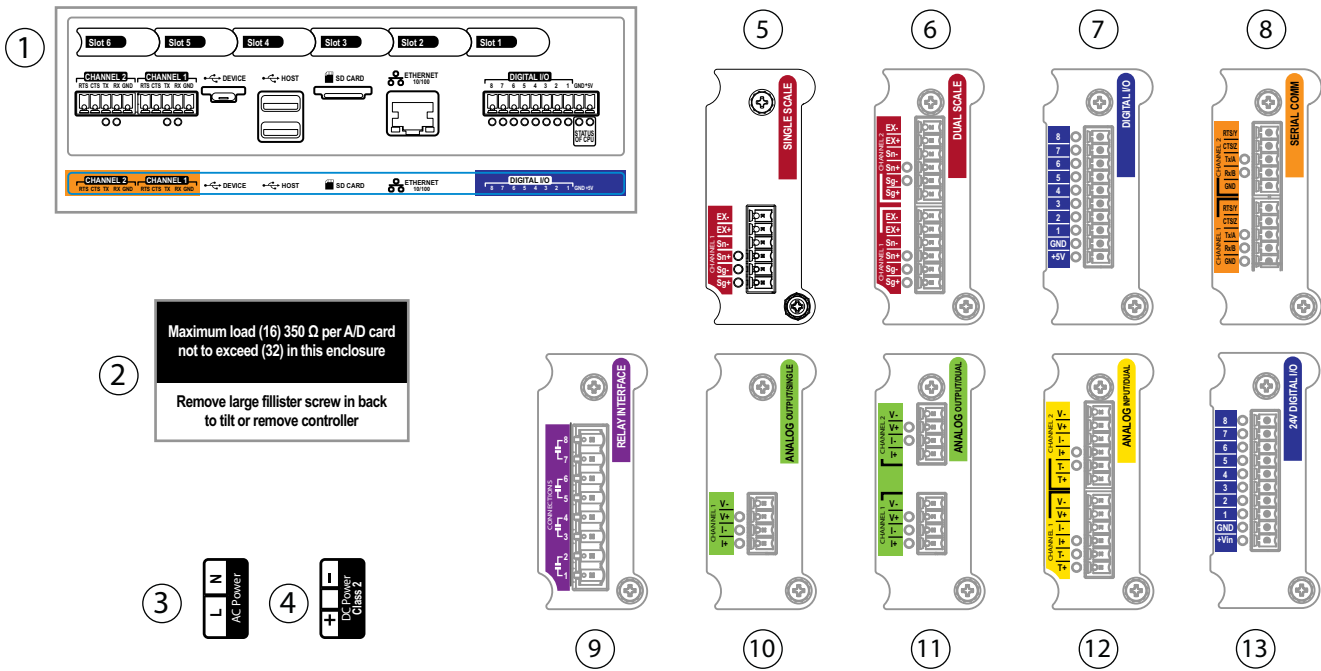

Figure 2-47. Label Repair Parts



NOTE: Numbers 5-12 display the position of labels on the option plate.

Item No.	Part No.	Description
1	167190	Label, 1280 Controller
2	168592	Label, Max Load (Universal Only)
3	167476	Label, AC Power 1280
4	167477	Label, DC Power 1280
5	167191	Label, Single Scale Option
6	167192	Label, Dual Scale Option
7	167193	Label, Digital IO Option
8	167194	Label, Serial Option
9	167195	Label, Relay Option
10	167196	Label, Analog Output (Single) Option
11	167197	Label, Analog Output (Dual) Option
12	167198	Label, Analog Input/Thermocouple (Dual) Option
13	221515	Label, 24V Digital IO Option

Table 2-15. Label Repair Parts List



3.0 Configuration Menu

Configuration has a series of menus which allow the parameters of the indicator to be set up. Detailed descriptions of the Scale Configuration, Communications, Features, Formats, Digital I/O, Analog Output, Setpoints and Diagnostics menus are provided in the 1280 Enterprise Series Technical Manual (PN 167659).



IMPORTANT: The audit trail jumper (JP1) needs to be disabled, in the off (right) position, in order to seal the setup switch with a lead wire seal. Access is not prevented simply by sealing the setup switch.

3.1 Access Setup Parameters

1. Press  on the weigh mode screen. The **Main Menu** displays.
2. Press  for access to the Configuration menu. If the Configuration menu does not appear, see the following note.



NOTE: To access Configuration through the front panel (by pressing the button on the touchscreen, jumper JP1 needs to be in the on (left) position. In order to restrict access to Configuration using the front panel, JP1 needs to be in the off (right) position, requiring the setup switch to access Configuration.

3. Access to the configuration menu may be restricted with a password. If prompted, enter the password and press . The Configuration menu displays.

3.2 Access Configuration Menu – Sealed Indicator

If the indicator has been sealed, there is a jumper in place (JP1) which does not allow access to the configuration menu on the touchscreen. Use the following instructions to enter configuration on a sealed indicator.

1. Break the wire seal.
2. Remove the large fillister screw.
3. Use a non-conductive tool to press the setup switch inside the indicator.

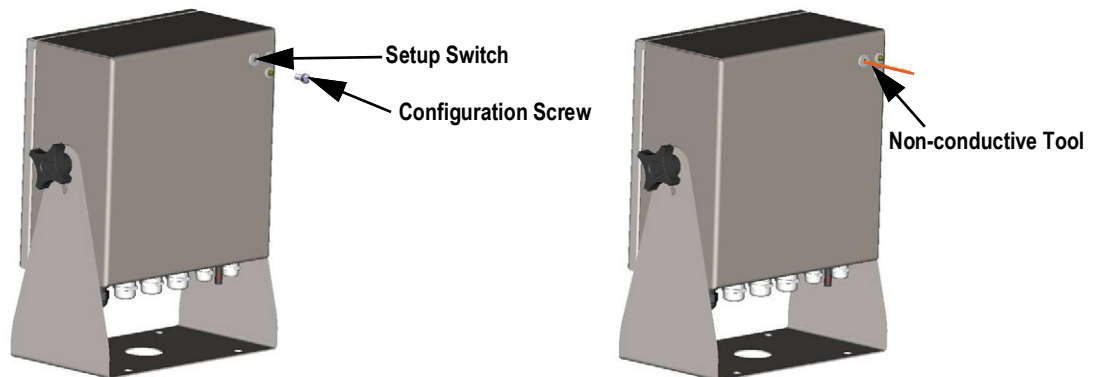

Figure 3-1. Setup Switch Location (Universal Enclosure)



IMPORTANT: press lightly to avoid damaging the switch or board.

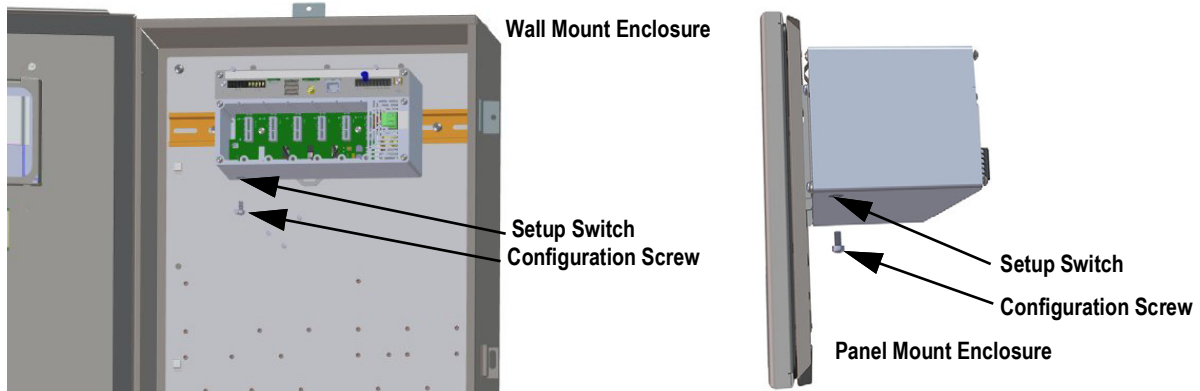

Figure 3-2. Setup Switch Locations (Panel/Wall Mount Enclosures)

4. Access to the configuration menu may be restricted with a password. If prompted, enter the password and press . The configuration menu displays.

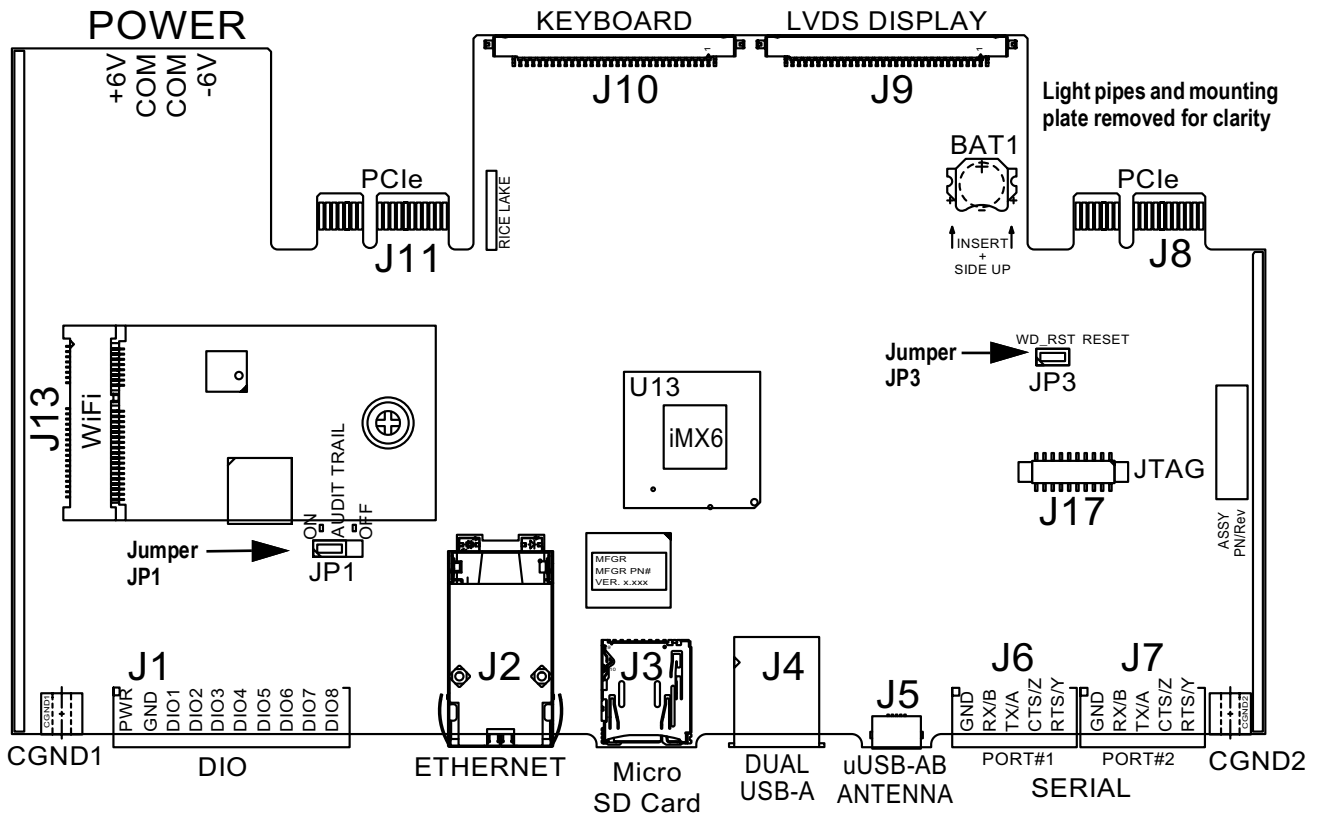

Figure 3-3. Jumper Locations



NOTE: The front door to the indicator may also be sealed to prevent access to the hardware. This may be required in some Legal for Trade applications.

3.3 Configuration Menu

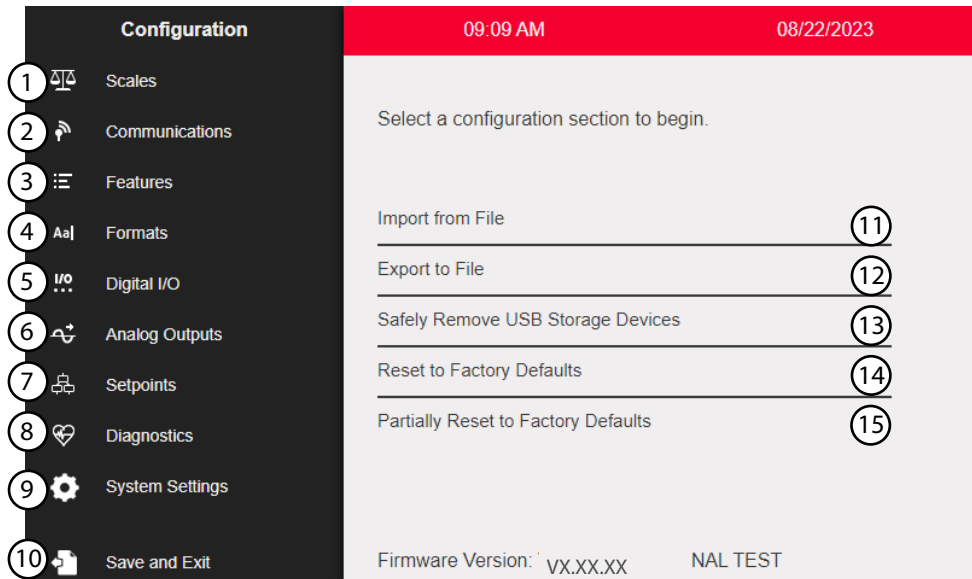

Figure 3-4. Configuration Menu

Item No.	Selection	Description
1	Scales Menu	Set the scale parameter
2	Communications Menu	Set the communication parameters
3	Features Menu	Set features parameters
4	Formats Menu	Set the print and stream format parameters
5	Digital I/O Menu	Assign functions to digital inputs and outputs
6	Analog Outputs Menu	Used to configure the analog output
7	Setpoints Menu	Used to configure setpoints
8	Diagnostics Menu	Recalibrate touchscreen and set the backlight
9	System Settings Menu	Used to set options for devices, email, cards and update utilities
10	Save and Exit Button	Press to save settings and return to weigh mode
11	Import From File	Press to import an existing file
12	Export to File	Press to export files
13	Safely Remove USB Storage Devices	Press to release the USB connection before removing the flash drive or USB cable to ensure the drive continues to work properly and does not become corrupt
14	Reset to Factory Defaults	Press to restore all settings to factory defaults
15	Partially Reset to Factory Defaults	Press to partially restore settings to factory defaults, this preserves Ethernet and scale settings

Table 3-1. Configuration Main Menus

Configuration Menu Map

Figure 3-5 illustrates the menu structure in the configuration menu selections.

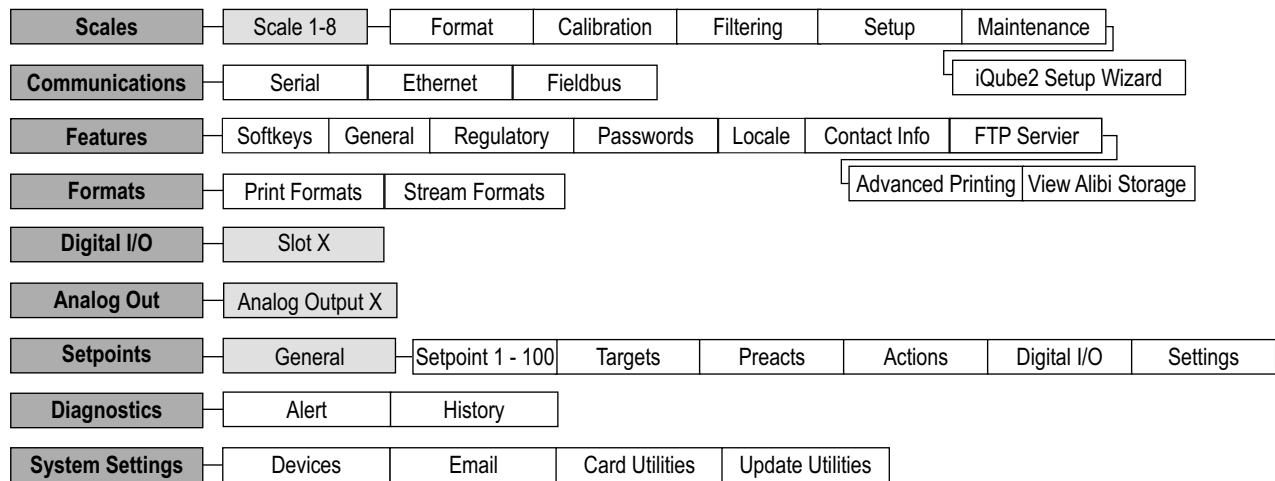

Figure 3-5. Configuration Menu Map

4.0 Specifications

Power:

AC voltages: 100 to 240 VAC; 50 /60 Hz
DC voltages: 11 to 30 VDC

Power Consumption:

60W

Excitation Voltage:

10 VDC (+/- 5 VDC)
16 × 350 ohm or 32 × 700 ohm load cells per A/D card

Analog Signal Input Range:

-60 mV to 60 mV

Analog Signal Sensitivity:

0.3 μ V/graduation minimum at 7.5 Hz to 120 Hz
1.0 μ V/graduation recommended

A/D Sample Rate:

7.5 to 960 Hz, software selectable

Resolution:

Internal: 8,000,000 counts
Display: 1,000,000

System Linearity:

\pm 0.01% full scale

Digital I/O:

Eight I/O channels on CPU board
Optional 24-channel I/O expansion boards

Communication Ports:

Port 1 & 2

- RS-232: Full Duplex
- RS-422/485: Half or Full Duplex

Baud rate: 1200 to 115200

Port 3: USB 2.0 Device (Micro)

USB host: (2) Type A connectors max 500 mA

Ethernet: Wired 10/100 Auto-MDX

Ethernet: Wireless 802.11 b/g/n 2.4GHz

Onboard:

Selectable filters: Three stage, adaptive or damping

Embedded Linux® OS

8 GB eMMC (system use)

1 GB DDR3 RAM

460 MB onboard database (SQLite) storage

Up to 32 GB microSD card (sold separately)

Display:

Seven-inch, 800 × 480 pixel, 500 or 1,000 NIT

Twelve-inch, 1280 × 800 pixel, 1,500 NIT

Keys/Buttons:

22-key membrane panel, tactile buttons, on-screen keyboard for text and numeric entry, USB port for flash drive, keyboard and printer

Temperature Range:

Certified: 14 °F to 104 °F (-10 °C to 40 °C)

Operating: -4 °F to 131 °F (-20 °C to 55 °C)

Rating/Material:

Universal: IP69K

Wall Mount: IP66

Panel Mount: IP69K, NEMA Type 4X and 12

Stainless steel 304 enclosure

Weight:

Universal enclosure: 11 lb (4.9 kg)

Panel mount enclosure: 8 lb (3.6 kg)

Wall mount enclosure: 23 lb (10.4 kg)

Panel mount 7 in touch-only: 7 lb (3.1 kg)

Panel mount 12 in touch-only: 10 lb (4.5 kg)

Warranty:

Two-year limited

EMC Immunity:

10 V/m

Certifications and Approvals



NTEP

CC Number: 15-001A1

Accuracy Class: III/IIIL; n_{max} : 10 000



OIML

File Number: R61-1/2017 TC8596

File Number: R76/2006-A-NL1-19.23

Accuracy Class: III/IIIL; n_{max} : 10 000



Measurement Canada

Approval: AM-5980C

Accuracy Class III/III HD n_{max} : 10 000



National Measurement Institute

Approval: NMI S820



NOM

Certificate No. 1602CE12346



UL Listed

Universal, Wall Mount



UL Recognized

Panel Mount





© Rice Lake Weighing Systems Content subject to change without notice.

230 W. Coleman St. • Rice Lake, WI 54868 • USA USA: 800-472-6703 • International: +1-715-234-9171