

Livestock Scales

TABLE OF CONTENTS

Livestock Scales	611
RoughDeck® SLV	612
<i>Single Animal Livestock Scale</i>	
RoughDeck® EQ	614
<i>Equine Floor Scale and Indicator Package</i>	
Farm Bars	616
<i>With 380 Indicator</i>	
Farm Bars	617
<i>Without Instrumentation</i>	

The following product names, logos, brands and other trademarks featured or referred to within this publication are the property of their respective trademark holders.

RoughDeck® SLV

Single Animal Livestock Scale



Approvals



Standard Features

- Mild steel construction
- Diamond safety thread plate deck
- Rigid-type structural steel channel frame
- NEMA Type 4X stainless steel side-access junction box without quick connector
- Signal trim summing board
- Four adjustable stainless steel SUREFOOT™ support feet
- SURVIVOR® EL147HE hostile environment load cell cable
- Four alloy steel load cells

Specifications

Full Scale Capacity:

4,000 lb, 1 lb increments

End Load Capacity:

125% full scale

Cable Length:

20 ft (6 m)

Warranty:

Two-year limited (scale only)

Approvals:

NTEP 92-001 Class III 4,000 d

Capacity not to exceed 4,000 lb x 1 lb and platform size not to exceed 32 sq ft

Part Number/Price

Part #	Capacity	Outside Dimensions	Est. Weight	Price
103617	4,000 lb, 20 ft without Quick Connect, modified to fit gate and rack (scale platform only)	8 × 3 ft	565 lb	\$3,700.00
78452	4,000 lb, 20 ft without Quick Connect (gate and rack not included) (scale platform only)	8 × 3 ft	565 lb	\$3,700.00
103619	4,000 lb, 20 ft without Quick Connect, modified to fit gate and rack (scale platform only)	8 × 4 ft	750 lb	\$3,800.00
78453	4,000 lb, 20 ft without Quick Connect (gate and rack not included) (scale platform only)	8 × 4 ft	750 lb	\$3,800.00
RoughDeck SLV 4,000 lb Bundle Package (Ships Assembled)				
231387	Scale Pkg, 3 × 8 ft, 4,000 lb capacity with swing gates, racks, kick plates, 380 Synergy indicator, factory calibrated prior to shipping with 1 lb increments.	8 × 3 ft	1,200 lb	\$6,500.00
231388	Scale Pkg, 3 × 8 ft, 4,000 lb capacity with slide gates, racks, kick plates, 380 Synergy indicator, factory calibrated prior to shipping with 1 lb increments.	8 × 3 ft	1,310 lb	\$9,200.00
231389	Scale Pkg, 4 × 8 ft, 4,000 lb capacity with swing gates, racks, kick plates, 380 Synergy indicator, factory calibrated prior to shipping with 1 lb increments.	8 × 4 ft	1,500 lb	\$7,100.00
231390	Scale Pkg, 4 × 8 ft, 4,000 lb capacity with slide gates, racks, kick plates, 380 Synergy indicator, factory calibrated prior to shipping with 1 lb increments.	8 × 4 ft	1,610 lb	\$9,800.00

Options/Accessories

Part #	Description	Price
Consult	Smooth deck instead of diamond safety tread plate	N/C
Consult	Stainless steel load cells (RL32018S IP66) and hardware	\$120.00 list price add-on
Consult	Stainless steel hermetically sealed load cells (RL32218S-HE IP69K) and hardware	\$440.00 list price add-on
Consult	Angle iron bolted to scale for wood deck provisions (wood to be supplied by customer)	\$225.00
Consult	Rubber mat	Consult
226036	380 universal segmented LCD display, battery powered, Synergy Series with 4-pin quick connect ag scale cable	\$785.00
18777	Floor anchor plates, mild steel (set of 2)	\$40.00
18778	Floor anchor plates, stainless steel (set of 2)	\$55.00

LIVESTOCK SCALES

Dimensions

RoughDeck SLV			
3 × 8 ft			
A	93.75 in	I	2.62 in
B	41.19 in	J	3.38 in
C	5.01 in	K	29.25 in
D	37.12 in	L	36.00 in
E	72.06 in	M	31.84 in
F	74.00 in (swing gate) 86.59 in (slide gate)	N	3.50 in
G	96.00 in	O	77.50 in (swing gate) 90.09 in (slide gate)
H	90.76 in	P	70.75 in
4 × 8 ft			
A	93.75 in	I	2.62 in
B	41.19 in	J	3.38 in
C	5.01 in	K	41.25 in
D	37.12 in	L	48.00 in
E	72.06 in	M	43.85 in
F	74.00 in (swing gate) 86.59 in (slide gate)	N	3.50 in
G	96.00 in	O	77.50 in (swing gate) 90.09 in (slide gate)
H	90.76 in	P	94.75 in

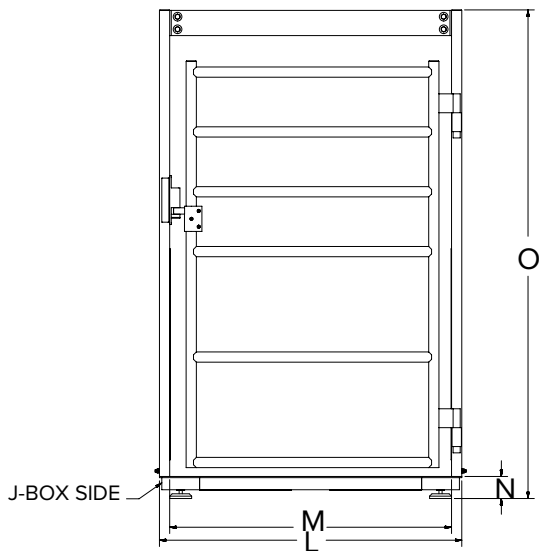
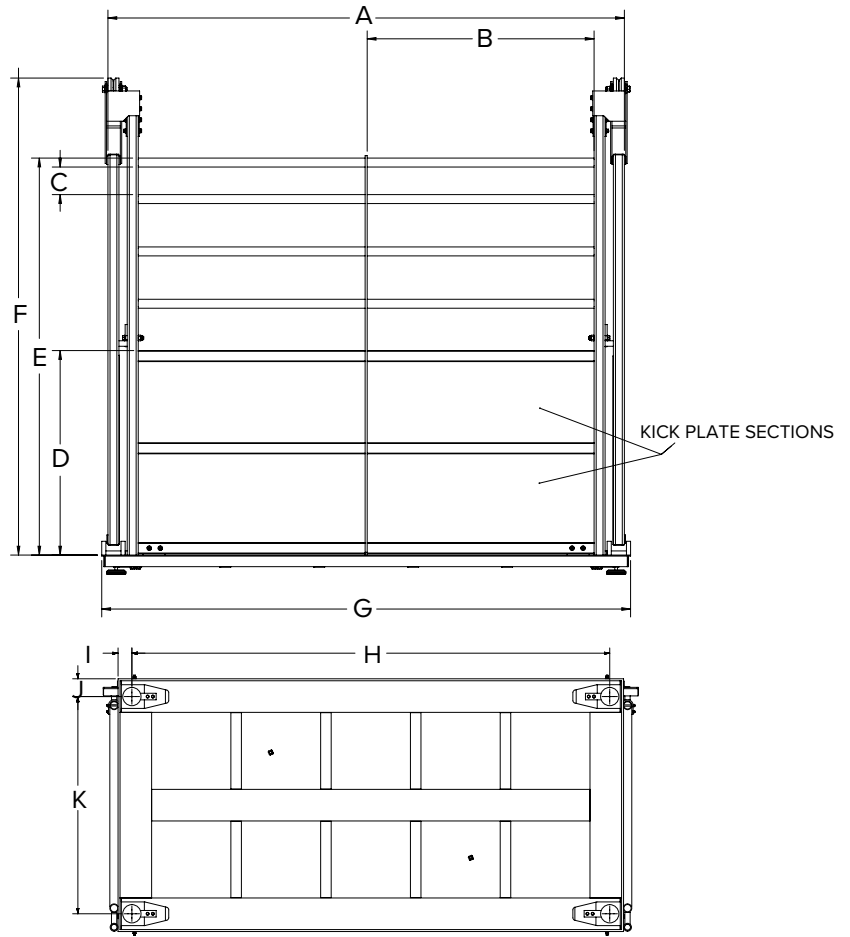

View of swing gate

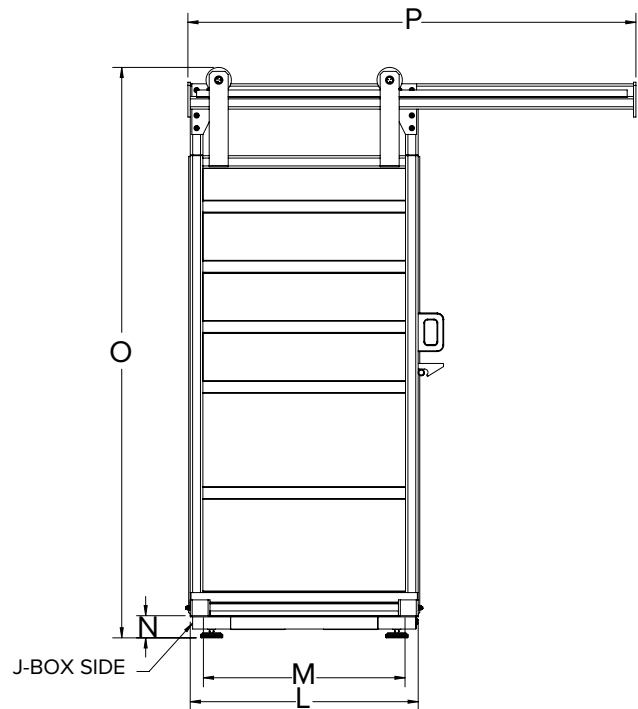

View of slide gate

LIVESTOCK SCALES

RoughDeck® EQ

Equine Floor Scale and Indicator Package

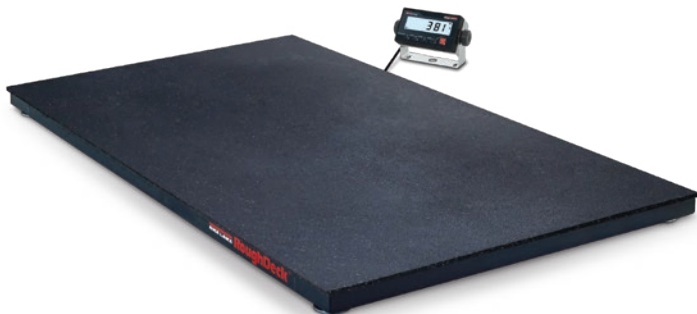

Standard Features

- Package includes 4 ft × 6 ft × 4.25 in floor scale with stall mat, 20 ft of SURVIVOR® EL147HE hostile environment load cell cable and indicator
- Mat thickness 0.75 in

Scale

- Heavy-duty design with structural steel channel frame
- Stall mat to reduce noise and instill equine comfort
- Four adjustable stainless steel SUREFOOT™ support feet
- Powder-coated black matte finish

Indicator

- LCD display
- Battery powered
- Push-button and keyed tare
- Two communication ports
- Five tactile buttons
- Configurable print formats
- ABS enclosure

Part Number/Price

Part #	Size (W × L × H)	Capacity	Est. Weight	Price
RoughDeck EQ Floor Scale with 381 Indicator				
231030	4 ft × 6 ft × 4.25 in	2,500 × 0.5 lb	610 lb	\$3,350.00

Note: Height includes stall mat

Options/Accessories

Part #	Description	Price
Consult	Access ramps	+ Consult list price add-on
Consult	Smooth deck instead of diamond safety tread plate	N/C
12839*	50 lb cast iron calibration weights	\$250.00
207812	Guide rail, 5.66 ft long × 4.36 ft high, field installable, black matte finish	+\$295.00 list price add-on
18777	Floor anchor plates	\$40.00
Consult	Hermetically sealed load cells	Consult

*Quantity of 5 weights is recommended for 10% of capacity.



RoughDeck EQ with two optional guide rails installed

RoughDeck EQ Specifications

End Load Capacity:

100% full scale at 2,500 lb

Load Cells:

Model RL32018 alloy steel environmentally sealed IP66

Junction Box:

Side access, TuffSeal JB4SS stainless steel, NEMA Type 4X with a signal card

Feet:

Stainless steel SUREFOOT, adjustable (+0.25 in or -0.125 in) for leveling the scale

Finish:

Powder coat painted, black matte

Cable Length:

20 ft (6.1 m) for connecting scale junction box to indicator

Threaded Eyebolt:

One lifting hole located in center of scale for easy install (requires 1/2-20NF eyebolt, not included)

Warranty:

Two-year limited

381 Specifications

Power:

Battery: AA or Nickel Metal Hydride (NiMH)
381-2D-AA Adapter: 115/230 VAC to 12 VDC
381-2D-NiMH Charger: 115/230 VAC

Battery Life:

AA: 40 hours with one × 350 ohm load cell
NiMH: 80 hours with one × 350 ohm load cell

Communication Ports:

One full-duplex RS-232
One USB 2.0

Display:

Six 1 in (25 mm) tall, LCD digits

Annunciators:

g, lb, t, tn, kg, oz, battery level, PT, LT, gross, zero, unstable, net

Keys/Buttons:

Five tactile buttons

Rating/Material:

AA Battery: IP54, ABS
NiMH Battery: IP66, ABS

Approvals:

NTEP 21-051 Class III/IIIL, 10,000 d
Measurement Canada AM-6184

Dimensions

RoughDeck EQ

4 ft × 6 ft × 4.25 in with No Optional Guide Rail

A	48.00 in	D	66.76 in
B	72.00 in	E	41.25 in
C	4.25 in		

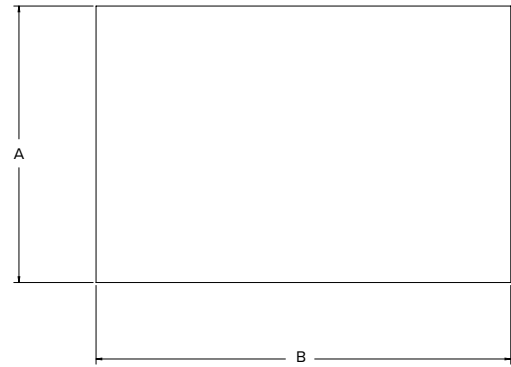
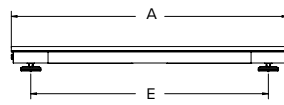
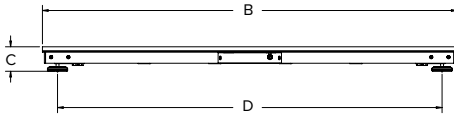

RoughDeck EQ

4 ft × 6 ft × 4.25 in with One Optional Guide Rail

A	50.25 in	F	4.25 in
B	48.00 in	G	66.76 in
C	72.00 in	H	48.00 in
D	67.90 in	I	41.25 in
E	52.26 in		

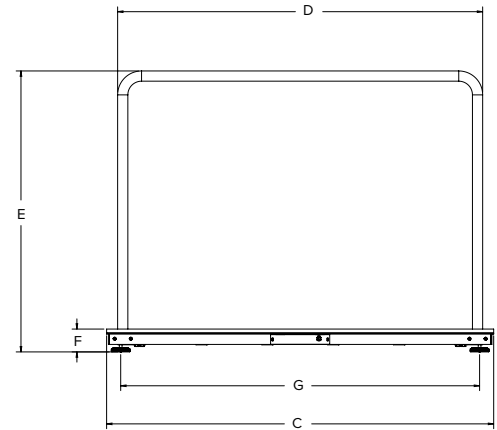
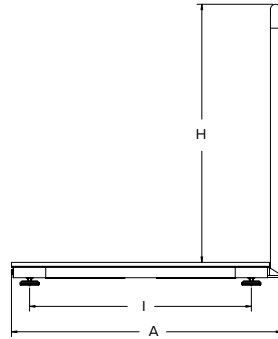
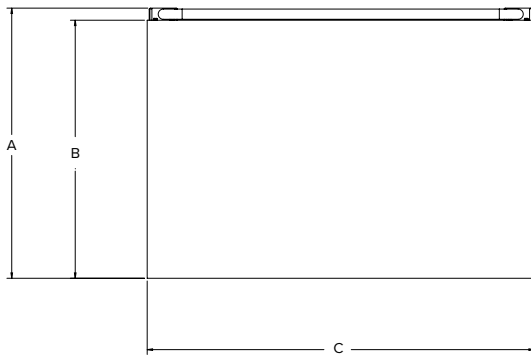

RoughDeck EQ

4 ft × 6 ft × 4.25 in with Two Optional Guide Rails

A	50.25 in	F	4.25 in
B	48.00 in	G	66.76 in
C	72.00 in	H	48.00 in
D	67.90 in	I	52.15 in
E	52.26 in	J	41.25 in

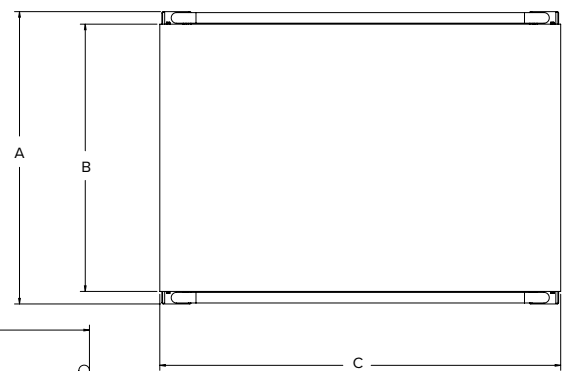
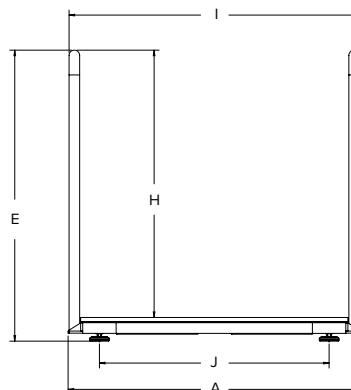
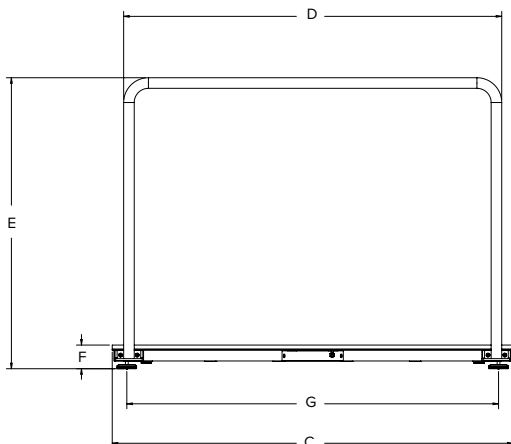

Farm Bars

With 380 Indicator

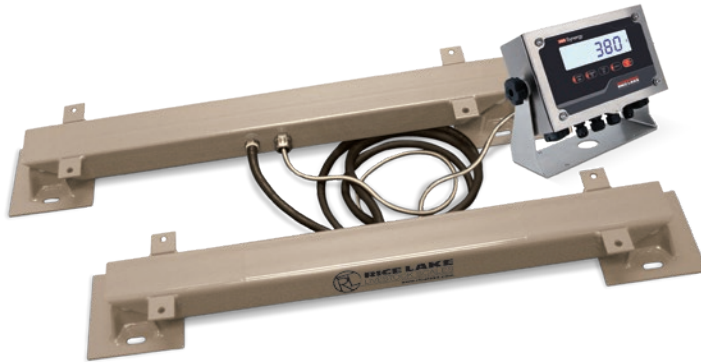

Part Number/Price

Part #	Description	Est. Weight	Price
With 380 Indicator			
2,500 lb Capacity			
214517	2,500U 22 – Farm Bar Kit, 22 in with 380, 2,500 capacity, square pads	98 lb	\$3,800.00
5,000 lb Capacity			
214518	5,000U 26 – Farm Bar Kit, 26 in with 380, 5,000 capacity, square pads	117 lb	\$4,300.00
214519	5,000U 33 – Farm Bar Kit, 33 in with 380, 5,000 capacity, square pads	123 lb	\$4,300.00
214520	5,000U 36 – Farm Bar Kit, 36 in with 380, 5,000 capacity, square pads	128 lb	\$4,300.00
214521	5,000U 40 – Farm Bar Kit, 40 in with 380, 5,000 capacity, square pads	134 lb	\$4,300.00
214522	5,000U 44 – Farm Bar Kit, 44 in with 380, 5,000 capacity, square pads	140 lb	\$4,300.00
214523	5,000U 48 – Farm Bar Kit, 48 in with 380, 5,000 capacity, square pads	146 lb	\$4,300.00
10,000 lb Capacity			
214524	10,000U 32 – Farm Bar Kit, 32 in with 380, 10,000 capacity, square pads	152 lb	\$5,400.00
214525	10,000U 36 – Farm Bar Kit, 36 in with 380, 10,000 capacity, square pads	152 lb	\$5,400.00
214526	10,000U 48 – Farm Bar Kit, 48 in with 380, 10,000 capacity, square pads	175 lb	\$5,400.00
214527	10,000U 60 – Farm Bar Kit, 60 in with 380, 10,000 capacity, square pads	210 lb	\$5,400.00
214528	10,000U 72 – Farm Bar Kit, 72 in with 380, 10,000 capacity, square pads	230 lb	\$5,400.00

Options/Accessories

Part #	Description	Price
159788	Extension cable, farm bar, 10 ft long	\$273.00
127556	Home run cable, 12 ft long, 4-pin male to blunt end, for indicator	\$130.00
202711	380 Universal Segmented LCD Display, Battery Powered	\$705.00
206433	Power supply, 12 V 6 W	\$60.00
23113	Printer TM-U295	\$693.00
71630	Scale tickets, 500/pack	\$60.00
15547	Blunt end to DB25, RS-232 cable for printer to indicator	\$70.00

Standard Features

- Indicator cable length 12 ft
- 3 ft ArmorGuard cable included
- Kit includes 380 Synergy Series digital weight indicator powered by four C-cell batteries (not included)
- Factory calibrated when sold with instrumentation
- Capacities from 2,500 to 10,000 lb
- Non-Legal for Trade

Specifications

Safe Overload:

150%

Full Scale Output:

3 mv/V nominal

Output is standardized for each model of load bar, consult factory for details

Maximum Excitation:

15 VDC

Nonlinearity:

0.02% full scale

Hysteresis:

0.02% full scale

Bridge Resistance:

350 ohm

Temperature:

-40 °F to 111 °F (-40 °C to 44 °C)

Cable Configuration:

8 ft cable between bars, hard-wired

12 ft cable with quick disconnect for the indicator

Warranty:

Two-year limited

380 Specifications

Power:

Batteries: Four alkaline C-cell (not included)

Optional: 115/230 VAC to 12 VDC adapter

Battery Life:

100 hours with 1 × 350 ohm load cell, no backlight

Communication Ports:

One RS-232 (three-wire)

One USB 2.0

Annunciators:

g, lb, t, tn, kg, oz, battery level, PT, LT, gross, zero, unstable, net

Display:

Six 1 in (25 mm) tall, LCD digits

Keys/Buttons:

Five tactile buttons

Rating/Material:

IP66

Stainless steel

Approvals:

NTEP 21-051

Measurement Canada AM-6184

CE

cULus

Farm Bars

Without Instrumentation



Standard Features

- 3 ft ArmorGuard cable included
- Capacities from 2,500 to 10,000 lb
- Non-Legal for Trade

Specifications

Safe Overload:

150%

Full Scale Output:

3 mv/V nominal

Output is standardized for each model of load bar, consult factory for details

Maximum Excitation:

15 VDC

Nonlinearity:

0.02% full scale

Hysteresis:

0.02% full scale

Bridge Resistance:

350 ohm

Temperature:

-40 °F to 111 °F (-40 °C to 44 °C)

Cable Configuration:

8 ft between bars, hard-wired

12 ft cable with quick disconnect for the indicator

Warranty:

Two-year limited

Part Number/Price

Part #	Description	Est. Weight	Price
2,500 lb Capacity			
152016	2,500 lb 22 – Farm Bar set, with square pads	92 lb	\$3,500.00
5,000 lb Capacity			
152018	5,000 lb 26 – Farm Bar set, with square pads	111 lb	\$3,900.00
152019	5,000 lb 33 – Farm Bar set, with square pads	117 lb	\$3,900.00
152020	5,000 lb 36 – Farm Bar set, with square pads	122 lb	\$3,900.00
152021	5,000 lb 40 – Farm Bar set, with square pads	128 lb	\$3,900.00
152022	5,000 lb 44 – Farm Bar set, with square pads	134 lb	\$3,900.00
152023	5,000 lb 48 – Farm Bar set, with square pads	140 lb	\$3,900.00
10,000 lb Capacity			
185437	10,000 lb 32 – Farm Bar set, with square pads	146 lb	\$4,800.00
152024	10,000 lb 36 – Farm Bar set, with square pads	146 lb	\$4,800.00
152025	10,000 lb 48 – Farm Bar set, with square pads	169 lb	\$4,800.00
152026	10,000 lb 60 – Farm Bar set, with square pads	204 lb	\$4,800.00
152027	10,000 lb 72 – Farm Bar set, with square pads	224 lb	\$4,800.00

Options/Accessories

Part #	Description	Price
159788	Extension cable, farm bar, 10 ft long	\$273.00
127556	Home run cable, 12 ft long, 4-pin male to blunt end, for indicator	\$130.00
202711	380 Universal Segmented LCD Display, Battery Powered	\$705.00
23113	Printer TM-U295	\$693.00
71630	Scale tickets, 500/pack	\$60.00
15547	Blunt end to DB25, RS-232 cable for printer to indicator	\$70.00
206433	Power supply, 12 V 6 W	\$60.00



PN 127556 Home-run cable

Farm Bars

Dimensions

Dimensions

Farm Bar 2,500U				
A	B*	C	D*	E
22.00 in	15.00 in	19.75 in	25.75 in	4.00 in

Farm Bar 5,000U				
A	B*	C	D*	E
26.00 in	19.00 in	23.75 in	29.75 in	4.00 in
33.00 in	26.00 in	30.75 in	36.75 in	4.00 in
36.00 in	29.00 in	33.75 in	39.75 in	4.00 in
40.00 in	33.00 in	37.75 in	43.75 in	4.00 in
44.00 in	37.00 in	41.75 in	47.75 in	4.00 in
48.00 in	41.00 in	45.75 in	51.75 in	4.00 in

Farm Bar 10,000U				
A	B*	C	D*	E
32.00 in	25.00 in	29.75 in	35.75 in	4.00 in
36.00 in	29.00 in	33.75 in	39.75 in	4.00 in
48.00 in	41.00 in	45.75 in	51.75 in	4.00 in
60.00 in	53.00 in	57.75 in	63.75 in	4.00 in
72.00 in	65.00 in	69.75 in	75.75 in	4.00 in

* B equals dimension A less 7 inches
* D equals dimension C plus 6 inches

