



Healthweigh®



ON/OFF

ZERO
0.0000
GROSS

REWEIGH

HOLD
RELEASE

TARE

ZERO



ENTER

UNITS
CLEAR

RICE LAKE
WEIGHING SYSTEMS

WARNING: TO PREVENT INFANT FALL, NEVER LEAVE INFANT UNATTENDED WHILE ON THIS SCALE.

PEDIATRIC SCALES
DIGITAL AND MECHANICAL

RL-DBS

DIGITAL BABY SCALE

The RL-DBS digital baby scale accurately weighs and measures even the most active babies. Simply place the baby on the scale, remove the baby and recall its weight by pressing the Recall key. The RL-DBS is portable, extremely durable, and easy to clean and maintain.

FEATURES

- Large 1-in LCD display
- Unit of measure locking
- Recall function to view last weight
- Automatic shut-off for long battery life
- Built-in measuring tape
- Optional carrying case

SPECIFICATIONS

Capacity:
44 lb × 0.5 oz (20 kg × 10 g)

Power:
Four AA alkaline batteries (included) or
AC adapter (included)

Battery Type:
Four AA alkaline (included)

Measuring Tape:
0 to 22.5 in (0 to 57 cm)

Approvals:
AC adapter: cULus

Warranty:
Two-year limited



Optional carrying case

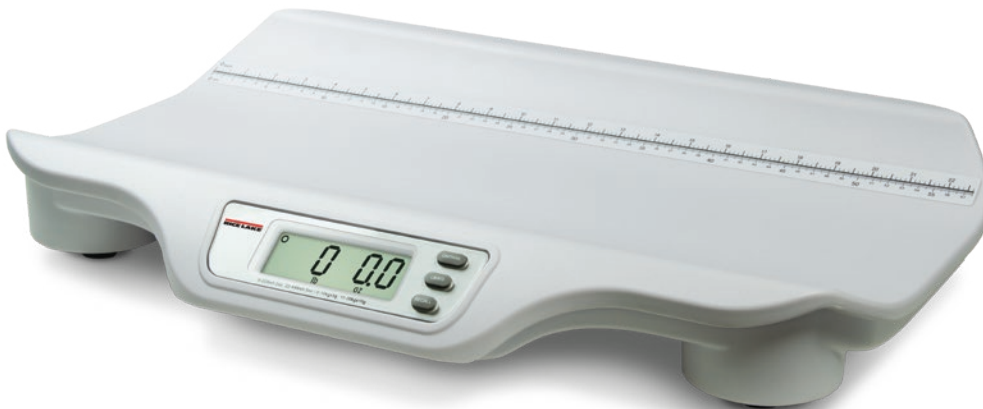



DIGITAL BABY SCALE

MODEL	CAPACITY		PART #
RL-DBS	44 lb x 0.5 oz (20 kg x 10 g)	120V AC adapter	107423
RL-DBS	44 lb x 0.5 oz (20 kg x 10 g)	230V AC adapter	112571

OPTIONS

DESCRIPTION	PART #
Carrying case	112570

SHIPPING WEIGHT

MODEL #	PART #	L (IN)	W (IN)	H (IN)	PACKAGE WGT. (LB)	DIM WGT. (LB)	SHIPPING WGT. (LB)
RL-DBS 120 V	107423	27	18	7	10	21	21
RL-DBS 230 V	112571	27	18	7	10	21	21

DIMENSIONS

	INCHES	CENTIMETERS		INCHES	CENTIMETERS
A	3.90	9.9	D	23.60	59.9
B	15.00	38.1	E	11.00	27.9
C	3.10	7.8			

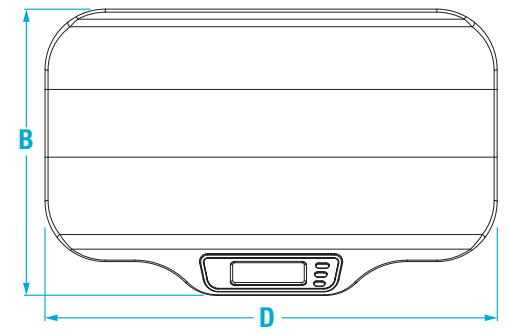
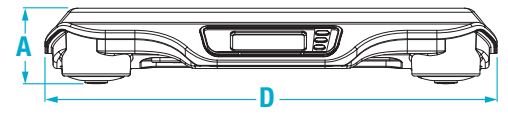
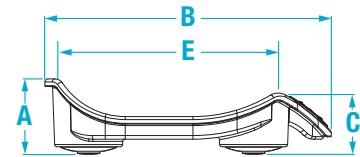

DUAL RANGE

RL-DBS-2

DIGITAL BABY SCALE

The RL-DBS-2 digital baby scale accurately weighs and measures even the most active babies, up to 44 pounds. Dual-range functionality provides enhanced precision for weighments from zero to 22 pounds with accuracy within 0.2 ounces. Simply place the baby on the scale, remove the baby and recall its weight by pressing the Recall key. The RL-DBS-2 is portable, extremely durable, and easy to clean and maintain.

FEATURES

- Large 1-inch LCD display
- Dual-range capacity for increased precision
- Accuracy within 5 g
- Unit of measure locking
- Recall function to view last weight
- Automatic shut-off for long battery life
- Built-in measuring tape
- Optional carrying case

SPECIFICATIONS

Capacity:

Range 1: 0 to 22 lb × 0.2 oz
(0 to 10 kg × 5 g)

Power:

Four AA alkaline batteries (included) or
AC adapter (included)

Battery Type:

Four AA alkaline (included)

Measuring Tape:

0 to 22.5 in (0 to 57 cm)

Approvals:

AC adapter: cULus

Warranty:

Two-year limited



Optional carrying case





DIGITAL BABY SCALE DUAL RANGE

MODEL	CAPACITY		PART #
RL-DBS-2	0 to 22lb x 0.2oz, 22 to 44lb x 0.5oz (0 to 10kg x 5g, 10 to 20kg x 10g)	120V AC adapter	155922
RL-DBS-2	0 to 22lb x 0.2oz, 22 to 44lb x 0.5oz (0 to 10kg x 5g, 10 to 20kg x 10g)	230V AC adapter	155923

OPTIONS

DESCRIPTION	PART #
Carrying case	112570

SHIPPING WEIGHT

MODEL #	PART #	L (IN)	W (IN)	H (IN)	PACKAGE WGT. (LB)	DIM WGT. (LB)	SHIPPING WGT. (LB)
RL-DBS-2 120 V	155922	27	18	7	10	21	21
RL-DBS-2 230 V	155923	27	18	7	10	21	21

DIMENSIONS

	INCHES	CENTIMETERS		INCHES	CENTIMETERS
A	3.90	9.9	D	23.60	59.9
B	15.00	38.1	E	11.00	27.9
C	3.10	7.8			

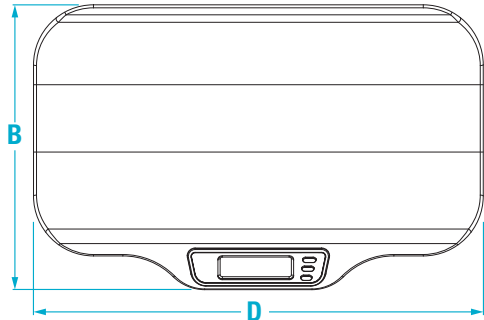
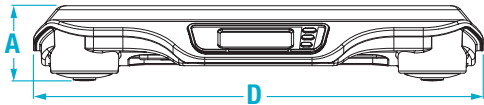
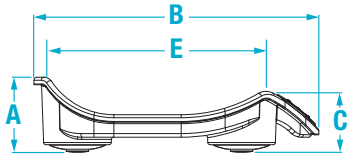

PG 71



DUAL RANGE

650-10-1 NEONATAL SCALE

The 650-10-1 neonatal baby scale precisely weighs even the most active babies, up to 33 pounds. Motiontrap™ movement compensation technology compensates for involuntary movements and provides a stable, accurate weight reading. Enhanced precision is essential especially when weighing premature infants. The 650-10-1 provides these precise weighments from zero to 10 pounds with accuracy within 0.05 ounces. A two-sided removable tray keeps babies safe and a built-in measuring tape ensures quick and easy measurements.

FEATURES

- LCD display
- Dual-range capacity for increased precision
- Unit of measure locking
- Automatic shut-off for long battery life
- Motiontrap™ movement compensation technology
- Built-in measuring tape

SPECIFICATIONS

Capacity:

Range 1: 0 to 10 lb × 0.05 oz
(0 to 5 kg × 1 g)

Range 2: 10 to 33 lb × 0.1 oz
(5 to 15 kg × 2 g)

Power:

9 VDC, provided by six AA lithium batteries (included) or AC adapter (optional)

Measuring Tape:

0 to 23.5 in × 0.125 in
(0 to 60 cm × 0.25 cm)

Battery Type:

Six Li-FeS₂ batteries

Temperature:

Operating:
50 °F to 95 °F (10 °C to 35 °C)

Display:

5-digit LCD display, 0.75 in (1.9 cm) digit height

Warranty:

Two-year limited





NEONATAL SCALE

MODEL	CAPACITY	POWER	PART #
650-10-1	0 to 10lb x 0.05 oz, 10 to 33lb x 0.1 oz (0 to 5kg x 1g, 5 to 15kg x 2g)	120V/230V	161784

OPTIONS

DESCRIPTION	PART #
9 VDC adapter, 100/240 V medical grade, cULus recognized	165138

SHIPPING WEIGHT

MODEL #	PART #	L (IN)	W (IN)	H (IN)	PACKAGE WGT. (LB)	DIM WGT. (LB)	SHIPPING WGT. (LB)
650-10-1	161784	18	28	11	25	40	40

DIMENSIONS

	INCHES	CENTIMETERS		INCHES	CENTIMETERS
A	23.94	60.8	D	10.50	26.7
B	16.95	43.1	E	3.11	7.9
C	6.29	16.0	F	13.34	33.9

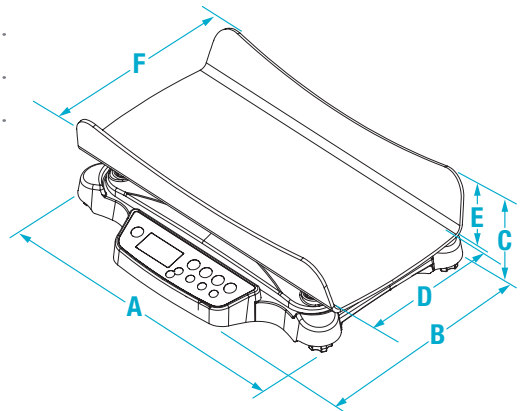

PG
73



LB & KG

RL-MIS MECHANICAL BABY SCALE

The RL-MIS mechanical baby scale provides safe, reliable measurement for infants of all sizes. An easy-to-clean tray also features a built-in measurement tape for simple length reference. The sturdy, painted beam offers dual-read capacity up to 135 pounds or 62 kilograms.

FEATURES

- Painted beam
- Sturdy, enameled steel body
- Easy-to-clean ABS plastic tray
- Dual-read capacity; lb and kg
- Built-in measuring tape

SPECIFICATIONS

Capacity:
135 lb × 1 oz (62 kg × 20 g)

Measuring Tape:
Measures 0 to 23 in
(0 to 58 cm)

Warranty:
Two-year limited





MECHANICAL BABY SCALE - LB AND KG BEAM

MODEL	CAPACITY	PART #
RL-MIS	135 lb x 1 oz (62 kg x 20g)	131470

SHIPPING WEIGHT

MODEL #	PART #	L (IN)	W (IN)	H (IN)	PACKAGE WGT. (LB)	DIM WGT. (LB)	SHIPPING WGT. (LB)
RL-MIS	131470	28	20	14	30	57	57

DIMENSIONS

	INCHES	CENTIMETERS		INCHES	CENTIMETERS
A	24.00	61.0	D	16.50	41.9
B	27.00	68.6	E	2.70	6.8
C	21.50	54.5	F	13.39	34.0

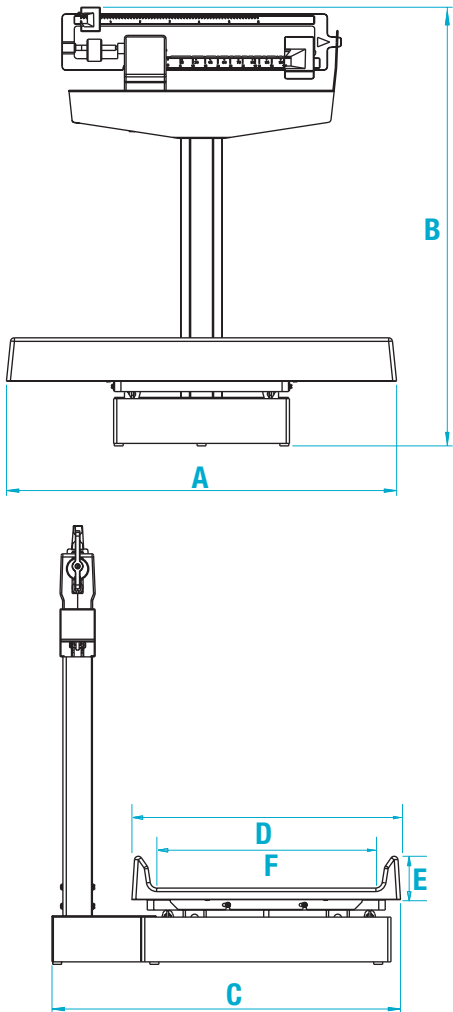

PG 75



KG Only

RL-MIS-20

MECHANICAL BABY SCALE

The RL-MIS-20 mechanical baby scale provides safe, reliable metric measurements for infants of all sizes. An easy-to-clean tray also features a built-in measurement tape for simple length reference. The sturdy, painted beam offers capacity readings up to 70 kilograms.

FEATURES

- Painted beam
- Sturdy, enameled steel body
- Easy-to-clean ABS plastic tray
- Unit of measure: kg
- Built-in measuring tape

SPECIFICATIONS

Capacity:
70 kg × 20 g

Measuring Tape:
0 to 58 cm





MECHANICAL BABY SCALE

MODEL	CAPACITY	PART #
RL-MIS-20	70kg x 20g	131471

SHIPPING WEIGHT

MODEL #	PART #	L (IN)	W (IN)	H (IN)	PACKAGE WGT. (LB)	DIM WGT. (LB)	SHIPPING WGT. (LB)
RL-MIS-20	131471	28	20	14	30	57	57

DIMENSIONS

	CENTIMETERS			CENTIMETERS	
A	61.0		D	41.9	
B	68.6		E	6.8	
C	54.5		F	34.0	

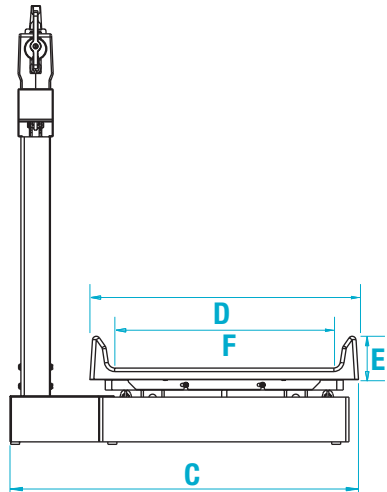
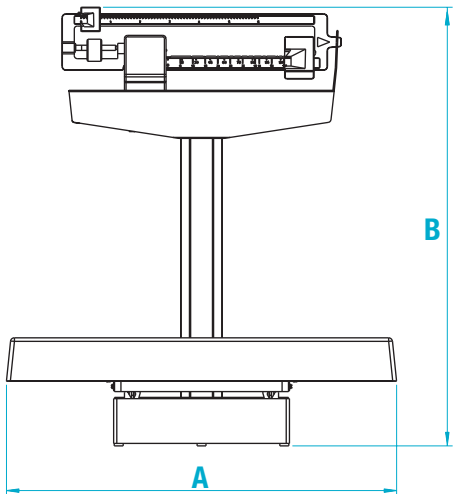



DIGITAL BABY SCALE

SUSPENDED INFANT SCALE

The OS-10/OS-25/OS-45 suspended infant scale is a portable device for the safe, accurate weighing of infants and toddlers up to 99 pounds (45 kilograms). Designed for use in any health environment, the OS-10/OS-25/OS-45 suspended infant scale is easily transported and powered by two AA batteries. Conveniently lift the infant using the sturdy steel s-hook attached to the optional canvas trousers. This pediatric scale is versatile in its applications, and the innovative weighing technique captures vital information safely and accurately.

FEATURES

- Hold function
- Units of measure lb/lb, oz/kg
- Adjustable automatic shut-off
- Ergonomic handheld design
- Battery operated, two AA batteries (included)
- Carrying case and top S-hook (included)
- Captured lower hook, removable upper hook (both hooks included)

SPECIFICATIONS

Capacity:

- OS-10:**
 22 lb × 0.02 lb
 22 lb × 0.25 oz
 10 kg × 0.01 kg

- OS-25:**
 55 lb × 0.05 lb
 55 lb × 0.5 oz
 25 kg × 0.02 kg

- OS-45:**
 99 lb × 0.1 lb
 99 lb × 1 oz
 45 kg × 0.05 kg

Power:

Two AA batteries (included)

Operating Temperature:

32 °F to 104 °F (0 °C to 40 °C)

Warranty:

One-year limited

Approvals:

CE Approved



*Optional
suspended pediatric
sling seat trousers*



Carrying case

Sturdy steel closed loop S-hook for safety

SUSPENDED INFANT SCALE

MODEL	CAPACITY	PART #
OS-10	22 × 0.02lb (22lb × 0.25 oz) (10 × 0.01 kg)	130292
OS-25	55 × 0.05lb (22lb × 0.5 oz) (25 × 0.02kg)	130293
OS-45	99 × 0.1lb (22lb × 1 oz) (45 × 0.05kg)	130294

OPTIONS

DESCRIPTION	PART #
Suspended pediatric sling seat trousers	141444

SHIPPING WEIGHT

MODEL #	PART #	L (IN)	W (IN)	H (IN)	PACKAGE WGT. (LB)	DIM WGT. (LB)	SHIPPING WGT. (LB)
OS-10	130292	10	5	3	2	2	2
OS-25	130293	10	5	3	2	2	2
OS-45	130294	10	5	3	2	2	2

DIMENSIONS

	INCHES	CENTIMETERS		INCHES	CENTIMETERS
A	14.30	36.3	C	1.30	3.3
B	3.60	9.1	D	11.60	29.5

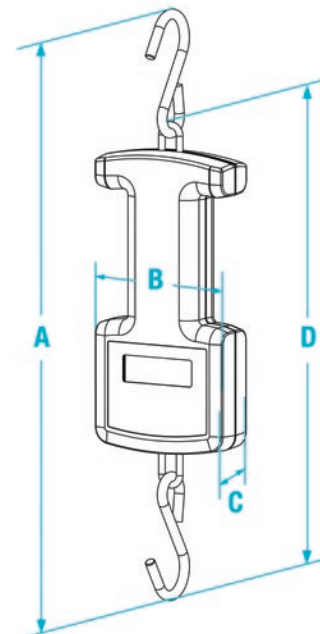

RL-WMS-10

WALL MOUNT STADIOMETER

Rice Lake's RL-WMS-10 wall mount stadiometer accurately measures height between 23 and 82 inches (58.4 and 208.2 centimeters). The RL-WMS-10 measures divisions of 1/16 inch (one millimeter). Users can quickly and easily obtain heights in either inches or centimeters. The aluminum-constructed RL-WMS-10 can be folded for compact storage when not in use and includes hardware for wall mounting.



FEATURES

- Aluminum construction
- Folding headpiece makes the product compact when not in use
- Measures both inches and centimeters
- Hardware included for mounting to metal, wood or drywall walls

SPECIFICATIONS

Measurement Range:
23 to 82 in (60 to 210 cm)

Height Divisions:
1/16 in (1 mm)

Warranty:
One-year limited



STADIOMETER

MODEL	CAPACITY	PART #
Master Carton (10 Stadiometers)		
RL-WMS-10	23 to 82 × 1/16in (60 to 120cm × 1 mm)	195263
Single Carton (1 Stadiometer)		
RL-WMS-10	23 to 82 × 1/16in (60 to 120cm × 1 mm)	206553

PG
81