

# SCT Weight Transmitter

30 Series

## Installation & Operator's Manual



**RICE LAKE**<sup>®</sup>  
WEIGHING SYSTEMS

To be the best by every measure<sup>®</sup>

159585



# Contents

---

<b>1.0</b>	<b>Introduction.....</b>	<b>1</b>
	1.1 Safety.....	1
	1.2 Specifications.....	4
	1.3 Electrical Connections.....	6
	1.4 Analog Output Type Selection.....	7
	1.5 Instrument Commissioning.....	8
<b>2.0</b>	<b>Calibration.....</b>	<b>9</b>
	2.1 Real Calibration (With Sample Weights).....	9
	2.2 Theoretical Calibration.....	10
	2.3 Digital Filtering.....	10
<b>3.0</b>	<b>RS-485 Serial Connection.....</b>	<b>11</b>
	3.1 Continuous One Way Transmission Protocol.....	11
	3.2 Modbus-RTU Protocol.....	11
	3.3 Alarms.....	13
<b>4.0</b>	<b>Reserved for the Installer.....</b>	<b>14</b>
	4.1 Restoring Factory Values.....	14
	4.2 Calibration and RS-485 Port Setting Access Limitation....	14



Technical training seminars are available through Rice Lake Weighing Systems. Course descriptions and dates can be viewed at [www.ricelake.com/training](http://www.ricelake.com/training) or obtained by calling 715-234-9171 and asking for the training department.

© Rice Lake Weighing Systems. All rights reserved. Printed in the United States of America. Specifications subject to change without notice.

Rice Lake Weighing Systems is an ISO 9001 registered company.  
December 05, 2013



*Rice Lake continually offers web-based video training on a growing selection of product-related topics at no cost. Visit [www.ricelake.com/webinars](http://www.ricelake.com/webinars).*

# 1.0 Introduction

---

## 1.1 Safety

### 1.1.1 Safety Symbol Definitions:



*Indicates a potentially hazardous situation that, if not avoided, could result in death or serious injury, and includes hazards that are exposed when guards are removed.*



**Important**

*Indicates information about procedures that, if not observed, could result in damage to equipment or corruption to and loss of data.*

### 1.1.2 Safety Precautions



*Failure to heed may result in serious injury or death.*



*Do not operate or work on this equipment unless you have read and understand the instructions and warnings in this manual. Contact any Rice Lake Weighing System dealer for replacement manuals. Proper care is your responsibility.*

*Risk of electrical shock. No user serviceable parts. Refer to qualified service personnel for service.*

*The unit has no power switch. To completely remove D/C power from the unit, disconnect the D/C power cable from the main socket.*

*DO NOT allow minors (children) or inexperienced persons to operate this unit.*

*DO NOT operate without all shields and guards in place.*

*DO NOT use for purposes other than weighing applications.*

*DO NOT place fingers into slots or possible pinch points.*

*DO NOT use this product if any of the components are cracked.*

*DO NOT make alterations or modifications to the unit.*

*DO NOT remove or obscure warning labels.*

*DO NOT use near water.*

### 1.1.3 Equipment Recommendations



**Important** *Failure to follow the installation recommendations will be considered a misuse of the equipment.*

#### To Avoid Equipment Damage

- Keep away from heat sources and direct sunlight.
- Protect the instrument from rain.
- Do not wash, dip in water or spill liquid on the instrument.
- Do not use solvents to clean the instrument.
- Do not install in areas subject to explosion hazard.

### 1.1.4 Correct Installation of Weighing Instruments

- The terminals indicated on the instrument's wiring diagram to be connected to ground must have the same potential as the scale structure (ground). If you are unable to ensure this condition, connect a ground wire between the instrument and the scale structure.
- The load cell cable must be run separately to the instrument input and not share a conduit with other cables. A shielded connection must be continuous without a splice.
- Use "RC" filters (quench-arcs) on the instrument-driven solenoid valve and remote control switch coils.
- Avoid electrical noise in the instrument panel; if inevitable, use special filters or sheet metal partitions to isolate.
- The panel installer must provide electrical protection for the instruments (fuses, door lock switch, etc.).
- It is advisable to leave equipment always switched on to prevent the formation of condensation.
- Maximum cable lengths:
  - RS-485: 1000 meters with AWG24, shielded and twisted cables
  - Analog current output: up to 500 meters with 0.5 mm<sup>2</sup> cable
  - Analog current output: up to 300 meters with 0.5 mm<sup>2</sup> cable

### 1.1.5 Correct Installation of the Load Cells

#### Installing Load Cells:

The load cells must be placed on rigid, stable structures within .5% of plumb and level. It is important to use mounting modules for load cells to compensate for misalignment of the support surfaces.

#### Protection Of The Load Cell Cable:

Use waterproof sheaths and joints in order to protect the cables of the load cells.

#### Mechanical Restraints (pipes, etc.):

When pipes are present, we recommend the use of hoses, flexible couplings and rubber skirted joints. In case of rigid conduit and pipes, place the pipe support or anchor bracket as far as possible from the weighed structure (at a distance at least 40 times the diameter of the pipe).

### Connecting Several Cells in Parallel:

Connect several load cells in parallel by using, if necessary, a watertight junction box with a terminal box. The load cell connection extension cables must be shielded, placed individually into their piping or conduit, and laid as far as possible from the power cables (in case of 4-wire connections, use cables with 4 x 1 sq.mm minimum cross-section).

### Welding:

Avoid welding with the load cells already installed. If this cannot be avoided, place the welder ground clamp close to the required welding point to prevent sending current through the load cell body.

### Windy Conditions - Shocks - Vibrations:

The use of weigh modules is strongly recommended for all load cells to compensate for misalignment of the support surfaces. The system designer must ensure that the scale is protected against lateral shifting and tipping relating to shocks and vibration, windy conditions, seismic conditions and stability of the support structure.

### Grounding The Weighed Structure:

By means of a 10 AWG solid or braided wire or braided grounding strap, connect the load cell upper support plate with the lower support plate, then connect all the lower plates to a single earth ground. Once installed, electrostatic charges are discharged to the ground without going through or damaging the load cells. Failure to implement a proper grounding system might not affect the operation of the weighing system; this, however, does not rule out the possibility that the load cells and connected instrument may become damaged by ESD. It is forbidden to ensure grounding system continuity by using metal parts contained in the weighed structure(see Figure 1-1).

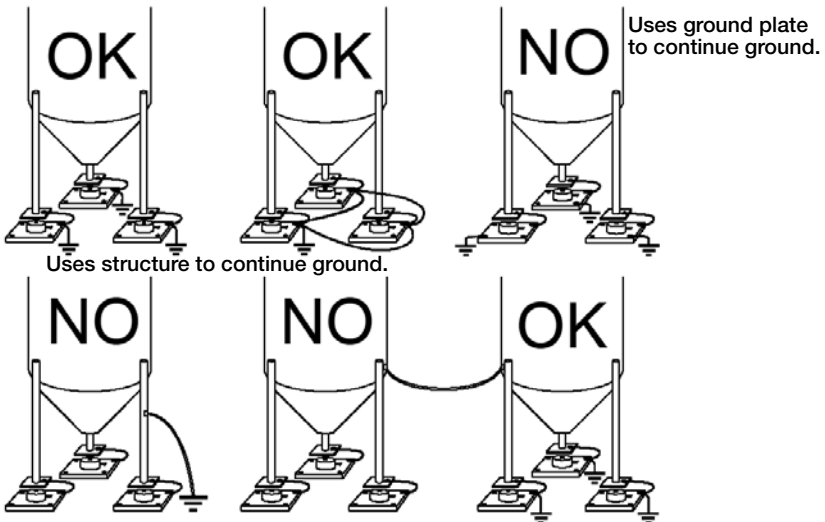

Figure 1-1. Installation Recommendations

## 1.1.6 Load Cell Testing

### Load Cell Resistance Measurement (Use a Digital Multimeter):

- Disconnect the load cells from the instrument and check that there is no moisture in the load cell junction box caused by condensation or water infiltration. If so, drain the system or replace it if necessary.
- The value between the positive signal wire and the negative signal wire must be equal or similar to the one indicated in the load cell data sheet (output resistance).
- The value between the positive excitation wire and the negative excitation wire must be equal or similar to the one indicated in the load cell data sheet (input resistance).
- The insulation value between the shield and any other load cell wire, and between any other load cell wire and the body of the load cell, must be higher than 20 Mohm (mega ohms).

### Load Cell Voltage Measurement (Use a Digital Multimeter):

- Remove weight of scale from load cell to be tested.
- Make sure that the excitation wires of the load cell connected to the instrument is 5 Vdc +/- 3%.
- Measure the millivolt signal between the positive and the negative signal wires by directly connecting them to the multi-meter, and make sure it reads between 0 and 0.5 mV (thousandths of a volt).
- Apply load to the load cell and make sure that there is a signal increment.



**Important** *If one of the above conditions is not met, please contact the technical assistance service.*

## 1.2 Specifications

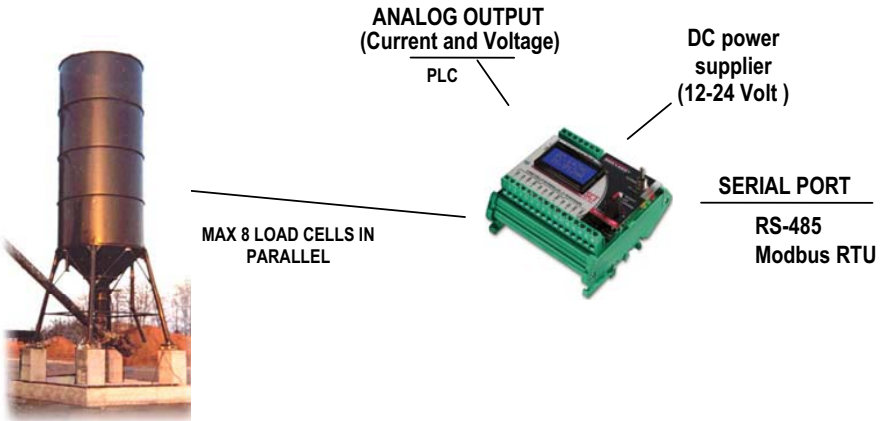

- Analog/serial weight transmitter suitable for assembly on back panel fitted Omega/DIN rail. Dimensions: 90x93x65 mm.
- Current or voltage 16 bit analog output.
- RS-485 serial output with Modbus RTU or continuous transmission protocol.
- Zero and full scale setting.
- Simultaneous display of the load cell reading in mV and of the analog output reading.
- Operating mode selection via 3-position selector switch, DIP switches, knob control and 2 line, 8 column alphanumeric display.



Power Supply And Consumption (VDC)	12 - 24 VDC $\pm$ 10% ; 5 W
No. of Load Cells in Parallel and Supply	max 8 ( 350 ohm ) ; 5VDC/120mA
Linearity / Analog Output Linearity	< 0.01% F.S. ; < 0.01% F.S.
Thermal Drift / Analog Output Thermal Drift	< 0.0005 % F.S. /°C ; < 0.003 % F.S./°C
A/D Converter	24 bit (16.000.000 points)
RS-485 Max Divisions	$\pm$ 200000 ( $\pm$ 10 mV with sens. 2 mV/V) $\pm$ 300000 ( $\pm$ 15 mV with sens. 3 mV/V)
Measurement Range	$\pm$ 39 mV
Max Sensitivity Of Usable Load Cells	$\pm$ 7 mV/V
Max Conversions Per Second	300 conversions/second
Digital Filter / Readings Per Second	0.003 - 4 sec / 10 - 300 Hz
Serial Ports	RS-485
Baud Rate	2400, 4800, 9600, 19200, 38400, 115200
Humidity (Non Condensing)	85%
Storage Temperature	- 30°C + 80°C
Operating Temperature	- 20°C + 60°C
Analog Output 16 Bit - 65535 Divisions	Current (max 400 ohms) 0-20 mA; 4-20 mA Voltage (min 2 kohm) 0-10 V; 0-5 V; $\pm$ 10 V $\pm$ 5 V

*Table 1-1. Technical Specifications*

### 1.3 Electrical Connections

- It is recommended that the negative side of the power supply be grounded.
- It is possible to power up to eight 350 ohm or sixteen 700 ohm load cells.
- Connect terminal “0 VDC” to the RS-485 common of the connected instruments in the event that these receive alternating current input or that they have an opto-isolated RS-485.

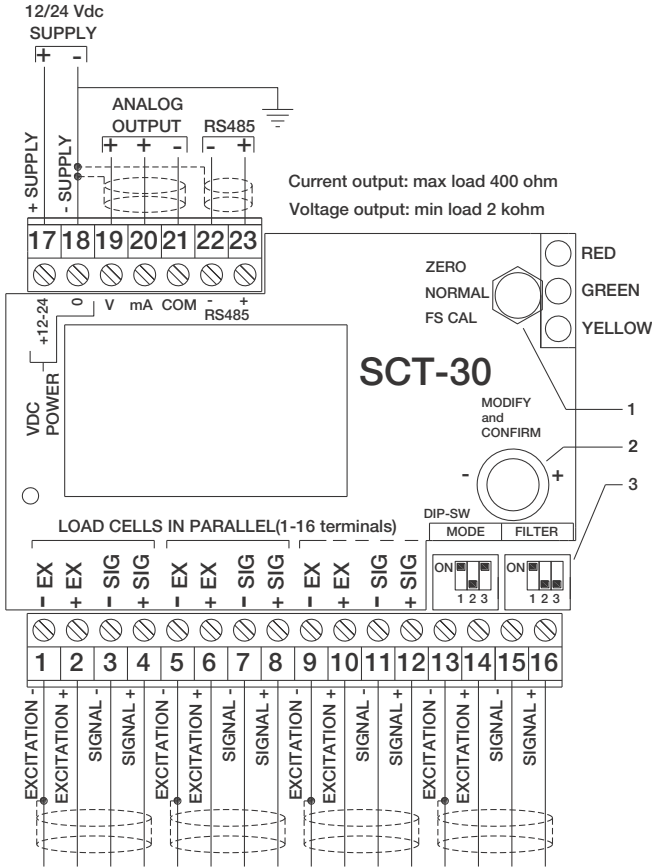

1: Selector switch    2: Knob control    3: DIP switch

Figure 1-2. Wiring Diagram

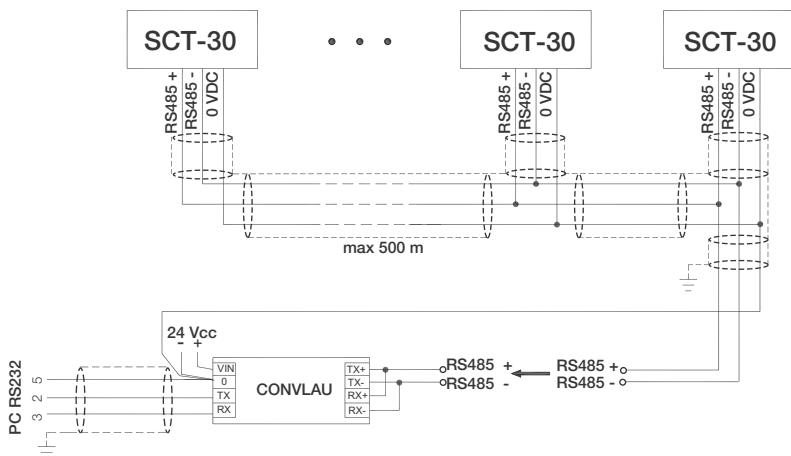

Figure 1-3. RS-485 Serial Connection



**Note** If the RS-485 network is longer than 100 meters or baud rates higher than 9600 are used, connect two 120 ohm terminating resistors between the '+' and '-' terminal strip ends of the instruments farthest away. Should there be different instruments or converters, refer to the specific manuals to determine whether it is necessary to connect the above-mentioned resistors.

## 1.4 Analog Output Type Selection

Set the indicated DIP switch with MODE.

DIP SWITCH			OPERATION MODE
1	2	3	
OFF	OFF	OFF	0-5 V
OFF	OFF	ON	0-10 V
OFF	ON	OFF	-5-5 V
OFF	ON	ON	-10-10 V
ON	OFF	ON	4-20 mA (default)
ON	ON	OFF	0-20 mA

By default, the instrument is calibrated to convert the load cell 0-10 mV to the selected analog output value.



**Note** By modifying the type of analog output, calibration will be brought back to default values.

## 1.5 Instrument Commissioning

1. Power on the transmitter and wait five minutes until all the components have reached a stable temperature.
2. Check that the display shows the mV value of the load cells and that when loading the load cells there is an increase in weight.
3. If there is not, check and verify the connections and correct positioning of the load cells.
4. Set the three-way selector switch to ZERO, the red LED will light.



**Note** *If the display reads BLOCK, zero setting is not enabled.*

5. The display shows the load cell reading in mV and the flashing zero value of the selected analog output (0 V, 0 mA or 4 mA); adjust the analog output value by turning the control knob.
6. Hold the control knob down until the display reads ZERO.
7. Release the control knob and set the selector switch back to NORMAL.



**Note** *Zero setting can also be obtained by referring to the values read by devices connected to the instrument, such as the PC or PLC.*

# 2.0 Calibration

---

Before carrying out the instrument real calibration, the type of analog output must be selected and the tare weight zero setting must be performed.

## 2.1 Real Calibration (With Sample Weights)

1. Load a sample weight (at least 50% of the full scale value) onto the weighing system.
2. Set the three-way selector switch to FS CAL. The yellow LED will light.



**Note** *If the display reads BLOCK, zero setting is not enabled.*

3. The display shows the load cell reading in mV and the corresponding flashing value of the analog output. Adjust the analog output value by turning the control knob.
4. Hold the control knob down until the display reads FS CAL.
5. Release the knob control and set the selector switch back to NORMAL.



**Note** *Calibration can also be obtained by referring to the values read by devices connected to the instrument, such as the PC or PLC.*

### **Example:**

*The weighing system uses four 1000 kg cells, the 4-20mA analog output has been selected and you wish to have 20 mA at 2000 kg. Check that the system is not loaded; perform the tare weight zero setting and load a sample weight of 1000 kg onto the system (equal to 50% of the required full scale value); move the selector switch to FS CAL and set the analog output value to 12 mA by working the knob control (range:  $20 - 4 = 16$  mA;  $\frac{1}{2}$  of the range:  $16 / 2 = 8$  mA;  $\frac{1}{2}$  of full scale:  $8 + 4 = 12$  mA); hold down the knob control until the display reads FS CAL; release the knob control and set the selector switch back to NORMAL.*

With this type of calibration it is possible to set the analog output value corresponding to a given value in mV read by the cell.

## 2.2 Theoretical Calibration



**Note** Theoretical calibration may be carried out with or without load cells connected to the instrument. The analog output is zero (4 mA for the 4-20 mA output case) when the value read by the cell is 0 mV.

1. Hold down the control knob and set the selector switch to **FS CAL** within four seconds. The yellow LED will light.
2. Release the control knob.
3. **5.000mV** will flash on the first line of the display. Adjust the value by turning the control knob.
4. Hold down the control knob for at least three seconds.
5. Upon releasing the control knob, line two on the display will start flashing.
6. Adjust the analog output value by turning the control knob.
7. Hold down the control knob for at least three seconds.
8. Upon releasing the control knob, the first display line begins to flash again. Confirm the settings by adjusting the selector switch to **NORMAL** or change the values again by repeating the above.



**Note** Ensure that the weighing system is not loaded and perform the tare weight zero setting.

### Example:

The weighing system uses four 1000 kg cells with 2 mV/V sensitivity, the 4-20mA analog output has been selected and you wish to have 20 mA at 2000 kg. Considering that the instrument provides 5 Vdc supply for the load cells, the cell full scale value is equal to  $2 \text{ mV/V} \times 5 \text{ V} = 10 \text{ mV}$ . Additionally, 2000 kg is equal to 50% of the system full scale ( $4 \times 1000 \text{ kg} = 4000 \text{ kg}$ ), therefore, the values to enter are 50% of  $10 \text{ mV} = 5 \text{ mV}$  and 20 mA.

## 2.3 Digital Filtering

The instrument has a digital filter to reduce the effects of weight oscillation. Set the DIP switch indicated by **FILTER**.



**Note** For an increased effect (weight more stable) increase the value of the response time.

DIP SWITCH			Response time [ms]	Display and serial port refresh frequency [Hz]
1	2	3		
OFF	OFF	OFF	3	300
OFF	OFF	ON	150	100
OFF	ON	OFF	260	50
OFF	ON	ON	425	25
ON	OFF	OFF	850	12.5 (default)
ON	OFF	ON	1700	12.5
ON	ON	OFF	2500	12.5
ON	ON	ON	4000	10

Table 2-1. Digital Filtering

## 3.0 RS-485 Serial Connection

The instrument transmits via RS-485 serial port, according to a continuous one way protocol or a querying protocol (MODBUS RTU). The division value will be between 0 and 200000 for load cell signal values between 0 and 10 mV.

For protocol setting, see Section 4.0.

### 3.1 Continuous One Way Transmission Protocol

The instrument transmits the number of divisions according to a continuous protocol via the following string:

xxxxxxCRLF

where: **xxxxxxx** = 6 division characters (48 – 57 ASCII).

**CR** = 1 carriage return character (13 ASCII).

**LF** = 1 new line character (10 ASCII).

### 3.2 Modbus-RTU Protocol

The MODBUS-RTU protocol enables to manage the reading and writing of the registers listed here below according to the specifications contained in the reference document for this standard Modicon PI-MBUS-300.

The numerical data listed below are expressed in hexadecimal notation if preceded by 0x.

#### Modbus-RTU Data Format

The data received and transmitted via the MODBUS-RTU protocol has the following format:

- 1 start bit
- 8 data bits, least significant bit sent first
- Parity none
- 1 stop bit

Of the controls available in the MODBUS-RTU protocol, only the READ HOLDING REGISTER control may be used (**code 0x03**).

The interrogation frequency is linked with the preset communication rate (the instrument will stand by for at least 3 bytes before beginning to calculate a possible response).

QUERY				
Address	Function	Add. Reg. 1	No. register	2 bytes
A	0x03	0x0000	0x0002	CRC

Tot. bytes = 8

<b>RESPONSE</b>					
<b>Address</b>	<b>Function</b>	<b>No. bytes</b>	<b>Register1</b>	<b>Register 2</b>	<b>2 bytes</b>
A	0x03	0x04	0x0064	0x00C8	CRC

Tot. bytes = 3+2\*No. registers+2

where: No. of registers = number of Modbus registers to be read, starting from register 1 address;

No. of bytes = number of following data bytes;

In the event of a string received correctly but not executable, the slave responds with an EXCEPTIONAL RESPONSE. The FUNCTION field is transmitted with the msb at 1.

<b>EXCEPTIONAL RESPONSE</b>			
<b>Address</b>	<b>Function</b>	<b>Code</b>	<b>2 bytes</b>
A	Funct + 0 x 80		CRC

<b>CODE</b>	<b>DESCRIPTION</b>
1	ILLEGAL FUNCTION (Function not valid or not supported)
2	ILLEGAL DATA ADDRESS (The specified data address is not available)
3	ILLEGAL DATA VALUE (The data received have no valid value)

The communication strings are controlled by CRC (Cyclical Redundancy Check).

In case of a communication error the slave will not respond with any string. The master must allow for a time-out before response reception and if no response is received, it infers that a communication error has occurred.

### **Registers and Values**

The instrument ModBus registers may only be read.

**H - L:** high half and low half - respectively, making up the DOUBLE WORD value.

<b>REGISTER</b>	<b>DESCRIPTION</b>
<b>40007</b>	<b>Status Register</b>
<b>40008</b>	H Divisions
<b>40009</b>	L Divisions



Status Register (40007)	
Bit 0	Cell Error (ERCEL)
Bit 1	AD Converter Malfunction (ER AD)
Bit 2	Off scale analog output (ER OL)
Bit 3	
Bit 7	Division negative sign
Bit 11	Weight stability
Bit 12	

### H&L DIVISIONS (40008-40009)

For additional examples regarding the generation of correct control characters (CRC16) refer to the manual **Modicon PI-MBUS-30**.

## 3.3 Alarms

Display	Description
<i>ErCEL</i>	Load cell is not connected or is incorrectly connected; the load cell signal exceeds 39 mV; the analog output generates the lowest possible value.
<i>ErOL</i>	The calculated analog signal is outside the allowed generating range:
<i>ErAd</i>	The conversion electronics is malfunctioning, the analog output generates the lowest possible value; check load cell connections, if necessary contact technical assistance.

### ANALOG OUTPUT VALUE UNDER ALARM CONDITIONS

ANALOG OUTPUT TYPE	Minimum	Maximum
0-10 V	-1.000	11.000
0-5 V	-1.000	5.500
-10-10 V	-11.000	11.000
-5-5 V	-5.500	5.500
0-20 mA	0.000	24.000
4-20 mA	0.000	24.000

## 4.0 Reserved for the Installer

---

### 4.1 Restoring Factory Values

1. Turn off the instrument and set the selector switch to ZERO.
2. While holding down the control knob, turn the instrument back on until the following is displayed:

**CANC**

**NO**

3. Release the control knob and set the selector switch to NORMAL.
4. Rotate the control knob to display **YES**.
5. Confirm by pressing the control knob. The instrument restarts and all parameters will be restored to factory values.

### 4.2 Calibration and RS-485 Port Setting Access Limitation

1. Turn on the instrument and set the selector switch to NORMAL.
2. Hold down the control knob for five seconds until the following is displayed:

**Block**

**No**

3. By working the control knob it is possible to select:
  - **No**: access allowed;
  - **Yes**: access denied for unauthorized staff; if the selector switch is set to ZERO or FS CAL the display will read **BLOCK**.
4. Confirm by holding down the control knob for at least three seconds.
5. Release it to shift to the next parameter. The display will show the address set for the RS485 serial connection protocol:

**Address**

**0**

6. By working the control knob it is possible to select:
  - **0**: continuous division transmission according to a frequency proportional to the set baud rate (30 Hz to 300 Hz with baud rate equal to 38400 bps);
  - **1-99**: querying Modbus RTU slave protocol.
7. Confirm by holding down the control knob for at least three seconds.
8. Release it to shift to the next parameter. The display will show the rate setting for RS-485 serial connection:

**Baud**

**9600**

9. By working the control knob the transmission rate can be adjusted (2400, 4800, 9600, 19200, 38400, 115200. Default: 9600 bps).
10. Confirm by holding down the control knob for at least three seconds.
11. Release it to exit the settings menu and return to normal instrument operation.

# SCT Weight Transmitter Limited Warranty

---

Rice Lake Weighing Systems (RLWS) warrants that all RLWS equipment and systems properly installed by a Distributor or Original Equipment Manufacturer (OEM) will operate per written specifications as confirmed by the Distributor/OEM and accepted by RLWS. All systems and components are warranted against defects in materials and workmanship for one year.

RLWS warrants that the equipment sold hereunder will conform to the current written specifications authorized by RLWS. RLWS warrants the equipment against faulty workmanship and defective materials. If any equipment fails to conform to these warranties, RLWS will, at its option, repair or replace such goods returned within the warranty period subject to the following conditions:

- Upon discovery by Buyer of such nonconformity, RLWS will be given prompt written notice with a detailed explanation of the alleged deficiencies.
- Individual electronic components returned to RLWS for warranty purposes must be packaged to prevent electrostatic discharge (ESD) damage in shipment. Packaging requirements are listed in a publication, *Protecting Your Components From Static Damage in Shipment*, available from RLWS Equipment Return Department.
- Examination of such equipment by RLWS confirms that the nonconformity actually exists, and was not caused by accident, misuse, neglect, alteration, improper installation, improper repair or improper testing; RLWS shall be the sole judge of all alleged non-conformities.
- Such equipment has not been modified, altered, or changed by any person other than RLWS or its duly authorized repair agents.
- RLWS will have a reasonable time to repair or replace the defective equipment. Buyer is responsible for shipping charges both ways.
- In no event will RLWS be responsible for travel time or on-location repairs, including assembly or disassembly of equipment, nor will RLWS be liable for the cost of any repairs made by others.

**THESE WARRANTIES EXCLUDE ALL OTHER WARRANTIES, EXPRESSED OR IMPLIED, INCLUDING WITHOUT LIMITATION WARRANTIES OF MERCHANTABILITY OR FITNESS FOR A PARTICULAR PURPOSE. NEITHER RLWS NOR DISTRIBUTOR WILL, IN ANY EVENT, BE LIABLE FOR INCIDENTAL OR CONSEQUENTIAL DAMAGES.**

**RLWS AND BUYER AGREE THAT RLWS' SOLE AND EXCLUSIVE LIABILITY HEREUNDER IS LIMITED TO REPAIR OR REPLACEMENT OF SUCH GOODS. IN ACCEPTING THIS WARRANTY, THE BUYER WAIVES ANY AND ALL OTHER CLAIMS TO WARRANTY.**

**SHOULD THE SELLER BE OTHER THAN RLWS, THE BUYER AGREES TO LOOK ONLY TO THE SELLER FOR WARRANTY CLAIMS.**

**NO TERMS, CONDITIONS, UNDERSTANDING, OR AGREEMENTS PURPORTING TO MODIFY THE TERMS OF THIS WARRANTY SHALL HAVE ANY LEGAL EFFECT UNLESS MADE IN WRITING AND SIGNED BY A CORPORATE OFFICER OF RLWS AND THE BUYER.**

© Rice Lake Weighing Systems, Inc. Rice Lake, WI USA. All Rights Reserved.

RICE LAKE WEIGHING SYSTEMS • 230 WEST COLEMAN STREET • RICE LAKE, WISCONSIN  
54868 • USA

# For More Information

---

## Web Site

Frequently Asked Questions (FAQs) at

<http://www.ricelake.com/faqs>

## Contact Information

### Hours of Operation

Knowledgeable customer service representatives are available

6:30 a.m. - 6:30 p.m. Monday through Friday

8 a.m. to 12 noon on Saturday. (CST)

### Telephone

Sales/Technical Support 800-472-6703

Canadian and Mexican Customers 800-321-6703

International 715-234-9171

### Immediate/Emergency Service

For immediate assistance call toll-free 1-800-472-6703 (Canadian and Mexican customers please call 1-800-321-6703).

If you are calling after standard business hours and have an urgent scale outage or emergency, press 1 to reach on-call personnel.

### Fax

Fax Number 715-234-6967

### E-mail

US sales and product information at

[prodinfo@ricelake.com](mailto:prodinfo@ricelake.com)

International (non-US) sales and product information at

[intlsales@ricelake.com](mailto:intlsales@ricelake.com)

### Mailing Address

Rice Lake Weighing Systems

230 West Coleman Street

Rice Lake, WI 54868 USA

# Notes

---

# Notes

---





230 W. Coleman St. • Rice Lake, WI 54868 • USA  
U.S. 800-472-6703 • Canada/Mexico 800-321-6703 • International 715-234-9171 • Europe +31 (0) 88 2349171

---

[www.ricelake.com](http://www.ricelake.com) [www.ricelake.mx](http://www.ricelake.mx) [www.ricelake.eu](http://www.ricelake.eu) [www.ricelake.co.in](http://www.ricelake.co.in) [m.ricelake.com](http://m.ricelake.com)