

# RT-D Roller Top In-Motion

Checkweighers and Conveyor Scales



## Standard Features

- Integrated overload protection
- Four load cell system
- Mild steel powder-coated frame
- Non powder-coated rollers
- Consult for custom sizes/capacities
- Weight threshold or single photoeye dynamic weighing modes

## RT-D Specifications

### Capacity

100 × 0.1 lb  
20 pcs/min max  
50-90 fpm

### Package Size Range:

8x4x4 – 44x32x24

## 682 Specifications

### Power:

Line voltage: 100 to 240 VAC, 50/60 Hz

### Excitation Voltage:

10 VDC (± 5 VDC), 8 × 350 ohm or  
16 × 700 ohm load cells

### Digital I/O:

Four configurable I/O, 5 V logic

### Digital I/O Dynamic Checkweighing Mode:

1. Photoeye Input
2. Under Output
3. Accept Output
4. Over Output

### Communication Ports:

Two full-duplex RS-232  
RS-485/422 (two-wire or four-wire)  
Micro USB (device)  
Ethernet TCP/IP (10/100)  
Wi-Fi

### Rating/Material:

IP69K (IP66 with RJ45 option)  
AISI 304 Stainless Steel

## Part Number/Price

Part #	Main Systems	Price
233778	RT-D checkweigher	Consult

## Dimensions

RT-D							
A	43.65 in	D	0.010 in TYP	G	.088 in	I	21.25 in
B	48.30 in	E	3.49 in	H	29.75 in +2.00 -1.00	J	3.20 in
C	16.00 in	F	3.15 in	I	21.25 in	K	36.00 in

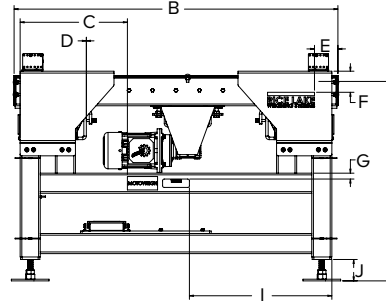
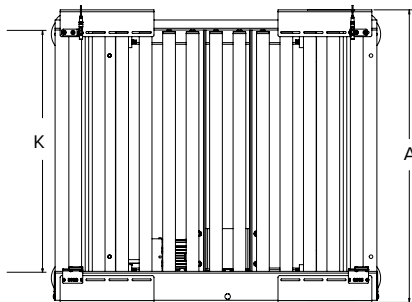

IN-MOTION  
WEIGHING