

# MotoWeigh® IMW

In-Motion Conveyor Scale and Checkweigher



## Approvals



Optional



Optional

## Standard Features

### Software

- Password protected user logins
- Real-time statistical information
- Product report
- Statistical report
- Parameter report
- User report
- Store up to 1,000 different products
- Five-zone classification

### Control Panel

- 1280 controller
- Power disconnect with lock-out/tag-out
- E-stop
- VFD (variable frequency drive)
- Motor overloads

### Hardware

- Square tube construction (SST or aluminum)
- 32 in height from top of belt with  $\pm 2.5$  in of adjustment
- Modular belting

## Options

- Divert methods:
  - Pneumatic pusher
  - Air blast
  - Drop conveyor
  - Paddle
  - Secondary diverter in series or parallel
- One-, three- or five -zone communication tower
- Audible alarm (non-washdown only)
- Draft shields
- Drop chutes
- Pull cord E-stops
- Portability package (non-NTEP Certified only)
- Conveyor guide rails (round or flat)
- Custom programming available
- Food-grade SST angle construction, NEMA Type 4X IP66 washdown systems
- Meets HACCP requirements
- UL 508
- NTEP Certified Legal for Trade (up to 2,000 divisions and 60 ppm)
- Pacing conveyor

## Specifications

### Construction:

- Stainless steel food-grade
- Stainless steel non-food-grade
- Aluminum non-food-grade

### Configurations:

- Checkweigher
- Conveyor scale

### Speed:

Up to 240 ft per minute

### Container Types:

- Boxes, bags, pouches, trays, tubs, cups, blister packs, display packs, clam shells

### Belts:

Intralox® Habasit®

### Power Configuration:

- 110 VAC single phase, 60 Hz
- 230/460 VAC 3 phase, 60 Hz

### Warranty:

- Two-year limited (excludes powertrain and wear parts)

### Checkweigher Packages:

- NTEP Certified and non-NTEP Certified packages available in stainless steel and aluminum for food and non-food-grade applications

### Checkweigher Packages Include:

- Common framework for mounting conveyor scale on same frame as infeed conveyor and indicator
- Basic control enclosure to interconnect wiring from photo eyes and divert solenoid and conveyor on/off/E-stop

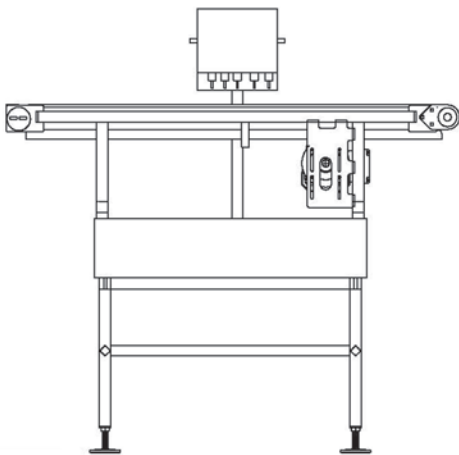
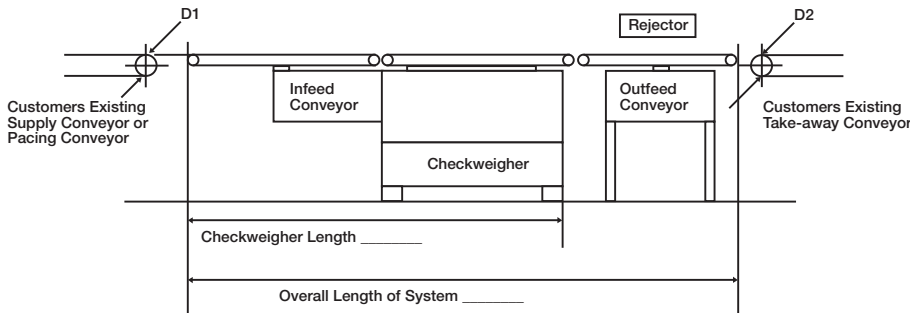

Side View  
Conveyor Scale

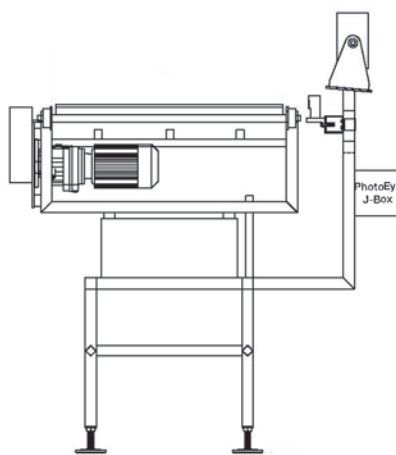

End View  
Conveyor Scale

Due to the variety of configurations, please consult a sales engineer to discuss application requirements and for complete specifications and price quotations.

Field installation available at pre-determined rates.

Questionnaire available at [www.ricelake.com/motoweigh](http://www.ricelake.com/motoweigh)

| Example Conveyor System Sizes and Configurations   |             |              |            |   |                        |
|--|-------------|--------------|------------|---|------------------------|
| Configuration  | Scale Width | Scale Length | Capacity   | PPM   | Material               |
| Scale Conveyor Only  | 6           | 12           | 10, 20     | Min Length: 3 in<br>Max Length (40ppm): 7 in<br>Max Length (75ppm): 3 in                    | AL, Ind Welded         |
|  |             |              |            |   | SST, Ind Welded        |
|  |             |              |            |   | SST, Food Grade Welded |
|  | 6           | 18           | 10, 20     | Min Length: 3 in<br>Max Length (40ppm): 11.5 in<br>Max Length (80ppm): 5 in                 | AL, Ind Welded         |
|  |             |              |            |   | SST, Ind Welded        |
|  |             |              |            |   | SST, Food Grade Welded |
|  | 6           | 24           | 10, 20     | Min Length: 3 in<br>Max Length (40ppm): 15.5 in<br>Max Length (80ppm): 7.5 in               | AL, Ind Welded         |
|  |             |              |            |   | SST, Ind Welded        |
|  |             |              |            |   | SST, Food Grade Welded |
| Checkweigher with Linear Thrust Reject Device (Includes: Infeed, scale, and outfeed conveyors. All conveyors same length.) | 6           | 12           | 10, 20     | Min Length: 3 in<br>Max Length (40ppm): 7 in<br>Max Length (75ppm): 3 in                    | AL, Ind Welded         |
|  |             |              |            |   | SST, Ind Welded        |
|  |             |              |            |   | SST, Food Grade Welded |
|  | 6           | 18           | 10, 20     | Min Length: 3 in<br>Max Length (40ppm): 11.5 in<br>Max Length (80ppm): 5 in                 | AL, Ind Welded         |
|  |             |              |            |   | SST, Ind Welded        |
|  |             |              |            |   | SST, Food Grade Welded |
|  | 6           | 24           | 10, 20     | Min Length: 3 in<br>Max Length (40ppm): 15.5 in<br>Max Length (80ppm): 7.5 in               | AL, Ind Welded         |
|  |             |              |            |   | SST, Ind Welded        |
|  |             |              |            |   | SST, Food Grade Welded |
| Scale Conveyor Only  | 12          | 18           | 10, 20, 40 | Min Length: 3 in (6 in@40 lb)<br>Max Length (40ppm): 11.5 in<br>Max Length (80ppm): 5 in    | AL, Ind Welded         |
|  |             |              |            |   | SST, Ind Welded        |
|  |             |              |            |   | SST, Food Grade Welded |
|  | 12          | 24           | 10, 20, 40 | Min Length: 3 in (6 in@40 lb)<br>Max Length (40ppm): 15.5 in<br>Max Length (80ppm): 7.5 in  | AL, Ind Welded         |
|  |             |              |            |   | SST, Ind Welded        |
|  |             |              |            |   | SST, Food Grade Welded |
|  | 12          | 30           | 10, 20, 40 | Min Length: 3 in (6 in@40 lb)<br>Max Length (40ppm): 20 in<br>Max Length (80ppm): 10 in     | AL, Ind Welded         |
|  |             |              |            |   | SST, Ind Welded        |
|  |             |              |            |   | SST, Food Grade Welded |
|  | 12          | 36           | 10, 20, 40 | Min Length: 3 in (6 in@40 lb)<br>Max Length (35ppm): 25.5 in<br>Max Length (70ppm): 15.5 in | AL, Ind Welded         |
|  |             |              |            |   | SST, Ind Welded        |
|  |             |              |            |   | SST, Food Grade Welded |
| Checkweigher with Linear Thrust Reject Device (Includes: Infeed, scale, and outfeed conveyors. All conveyors same length.) | 12          | 18           | 10, 20, 40 | Min Length: 3 in (6 in@40 lb)<br>Max Length (40ppm): 11.5 in<br>Max Length (80ppm): 5 in    | AL, Ind Welded         |
|  |             |              |            |   | SST, Ind Welded        |
|  |             |              |            |   | SST, Food Grade Welded |
|  | 12          | 24           | 10, 20, 40 | Min Length: 3 in (6 in@40 lb)<br>Max Length (40ppm): 15.5 in<br>Max Length (80ppm): 7.5 in  | AL, Ind Welded         |
|  |             |              |            |   | SST, Ind Welded        |
|  |             |              |            |   | SST, Food Grade Welded |
|  | 12          | 30           | 10, 20, 40 | Min Length: 3 in (6 in@40 lb)<br>Max Length (40ppm): 20 in<br>Max Length (80ppm): 10 in     | AL, Ind Welded         |
|  |             |              |            |   | SST, Ind Welded        |
|  |             |              |            |   | SST, Food Grade Welded |
|  | 12          | 36           | 10, 20, 40 | Min Length: 3 in (6 in@40 lb)<br>Max Length (35ppm): 25.5 in<br>Max Length (70ppm): 15.5 in | AL, Ind Welded         |
|  |             |              |            |   | SST, Ind Welded        |
|  |             |              |            |   | SST, Food Grade Welded |

IN-MOTION WEIGHING

# MotoWeigh® IMW

In-Motion Conveyor Scale and Checkweigher

## Example Conveyor System Sizes and Configurations

| Configuration  | Scale Width | Scale Length | Capacity   | PPM   | Material               |
|--|-------------|--------------|--|---|------------------------|
| Scale Conveyor Only  | 18          | 24           | 20, 40, 100  | Min Length: 6 in (3 in@20 lb)<br>Max Length (40ppm): 15.5 in<br>Max Length (80ppm): 7.5 in  | AL, Ind Welded         |
|  |             |              |  |   | SST, Ind Welded        |
|  |             |              |  |   | SST, Food Grade Welded |
|  | 18          | 30           | 20, 40, 100  | Min Length: 6 in (3 in@20 lb)<br>Max Length (40ppm): 20 in<br>Max Length (80ppm): 10 in     | AL, Ind Welded         |
|  |             |              |  |   | SST, Ind Welded        |
|  |             |              |  |   | SST, Food Grade Welded |
|  | 18          | 36           | 20, 40, 100  | Min Length: 6 in (3 in@20 lb)<br>Max Length (35ppm): 25.5 in<br>Max Length (70ppm): 15.5 in | AL, Ind Welded         |
|  |             |              |  |   | SST, Ind Welded        |
|  |             |              |  |   | SST, Food Grade Welded |
|  | 18          | 42           | 20, 40, 100  | Min Length: 6 in (3 in@20 lb)<br>Max Length (30ppm): 32 in<br>Max Length (60ppm): 22 in     | AL, Ind Welded         |
|  |             |              |  |   | SST, Ind Welded        |
|  |             |              |  |   | SST, Food Grade Welded |
| 18   | 48          | 20, 40, 100  | Min Length: 6 in (3 in@20 lb)<br>Max Length (30ppm): 36.5 in<br>Max of 54ppm | AL, Ind Welded  |                        |
|  |             |              |  | SST, Ind Welded   |                        |
|  |             |              |  | SST, Food Grade Welded  |                        |
| Checkweigher with Linear Thrust Reject Device (Includes: Infeed, scale, and outfeed conveyors. All conveyors same length.) | 18          | 24           | 20, 40, 100  | Min Length: 6 in (3 in@20 lb)<br>Max Length (40ppm): 15.5 in<br>Max Length (80ppm): 7.5 in  | AL, Ind Welded         |
|  |             |              |  |   | SST, Ind Welded        |
|  |             |              |  |   | SST, Food Grade Welded |
|  | 18          | 30           | 20, 40, 100  | Min Length: 6 in (3 in@20 lb)<br>Max Length (40ppm): 20 in<br>Max Length (80ppm): 10 in     | AL, Ind Welded         |
|  |             |              |  |   | SST, Ind Welded        |
|  |             |              |  |   | SST, Food Grade Welded |
|  | 18          | 36           | 20, 40, 100  | Min Length: 6 in (3 in@20 lb)<br>Max Length (35ppm): 25.5 in<br>Max Length (70ppm): 15.5 in | AL, Ind Welded         |
|  |             |              |  |   | SST, Ind Welded        |
|  |             |              |  |   | SST, Food Grade Welded |
|  | 18          | 42           | 20, 40, 100  | Min Length: 6 in (3 in@20 lb)<br>Max Length (30ppm): 32 in<br>Max Length (60ppm): 22 in     | AL, Ind Welded         |
|  |             |              |  |   | SST, Ind Welded        |
|  |             |              |  |   | SST, Food Grade Welded |
| 18   | 48          | 20, 40, 100  | Min Length: 6 in (3 in@20 lb)<br>Max Length (30ppm): 36.5 in<br>Max of 54ppm | AL, Ind Welded  |                        |
|  |             |              |  | SST, Ind Welded   |                        |
|  |             |              |  | SST, Food Grade Welded  |                        |
| Scale Conveyor Only  | 24          | 30           | 40, 100  | Min Length: 6 in<br>Max Length (40ppm): 20 in<br>Max Length (80ppm): 10 in                  | AL, Ind Welded         |
|  |             |              |  |   | SST, Ind Welded        |
|  |             |              |  |   | SST, Food Grade Welded |
|  | 24          | 36           | 40, 100  | Min Length: 6 in<br>Max Length (35ppm): 25.5 in<br>Max Length (70ppm): 15.5 in              | AL, Ind Welded         |
|  |             |              |  |   | SST, Ind Welded        |
|  |             |              |  |   | SST, Food Grade Welded |
|  | 24          | 42           | 40, 100  | Min Length: 6 in<br>Max Length (30ppm): 32 in<br>Max Length (60ppm): 22 in                  | AL, Ind Welded         |
|  |             |              |  |   | SST, Ind Welded        |
|  |             |              |  |   | SST, Food Grade Welded |
|  | 24          | 48           | 40, 100  | Min Length: 6 in<br>Max Length (30ppm): 36.5 in<br>Max of 54ppm                             | AL, Ind Welded         |
|  |             |              |  |   | SST, Ind Welded        |
|  |             |              |  |   | SST, Food Grade Welded |
| 24   | 54          | 40, 100      | Min Length: 6 in<br>Max Length (30ppm): 41.5 in<br>Max of 48ppm              | AL, Ind Welded  |                        |
|  |             |              |  | SST, Ind Welded   |                        |
|  |             |              |  | SST, Food Grade Welded  |                        |
| 24   | 60          | 40, 100      | Min Length: 6 in<br>Max Length (30ppm): 46 in<br>Max of 44ppm                | AL, Ind Welded  |                        |
|  |             |              |  | SST, Ind Welded   |                        |
|  |             |              |  | SST, Food Grade Welded  |                        |

IN-MOTION WEIGHING

| Example Conveyor System Sizes and Configurations   |  |              |          |  |  |                        |
|--|--|--------------|----------|--|--|------------------------|
| Configuration  | Scale Width  | Scale Length | Capacity | PPM  | Material   |                        |
| Checkweigher with Linear Thrust Reject Device (Includes: Infeed, scale, and outfeed conveyors. All conveyors same length.) | 24   | 30           | 40, 100  | Min Length: 6 in<br>Max Length (40ppm): 20 in<br>Max Length (80ppm): 10 in     | AL, Ind Welded   |                        |
|  |  |              |          |  | SST, Ind Welded  |                        |
|  |  |              |          |  | SST, Food Grade Welded   |                        |
|  | 24   | 36           | 40, 100  | Min Length: 6 in<br>Max Length (35ppm): 25.5 in<br>Max Length (70ppm): 15.5 in | AL, Ind Welded   |                        |
|  |  |              |          |  | SST, Ind Welded  |                        |
|  |  |              |          |  | SST, Food Grade Welded   |                        |
|  | 24   | 42           | 40, 100  | Min Length: 6 in<br>Max Length (30ppm): 32 in<br>Max Length (60ppm): 22 in     | AL, Ind Welded   |                        |
|  |  |              |          |  | SST, Ind Welded  |                        |
|  |  |              |          |  | SST, Food Grade Welded   |                        |
|  | 24   | 48           | 40, 100  | Min Length: 6 in<br>Max Length (30ppm): 36.5 in<br>Max of 54ppm                | AL, Ind Welded   |                        |
|  |  |              |          |  | SST, Ind Welded  |                        |
|  |  |              |          |  | SST, Food Grade Welded   |                        |
|  | 24   | 54           | 40, 100  | Min Length: 6 in<br>Max Length (30ppm): 41.5 in<br>Max of 48ppm                | AL, Ind Welded   |                        |
|  |  |              |          |  | SST, Ind Welded  |                        |
|  |  |              |          |  | SST, Food Grade Welded   |                        |
|  | 24   | 60           | 40, 100  | Min Length: 6 in<br>Max Length (30ppm): 46 in<br>Max of 44ppm                  | AL, Ind Welded   |                        |
|  |  |              |          |  | SST, Ind Welded  |                        |
|  |  |              |          |  | SST, Food Grade Welded   |                        |
| Scale Conveyor Only  | 30   | 36           | 100, 200 | Min Length: 6 in<br>Max Length (35ppm): 25.5 in<br>Max Length (70ppm): 15.5 in | AL, Ind Welded   |                        |
|  |  |              |          |  | SST, Ind Welded  |                        |
|  |  |              |          |  | SST, Food Grade Welded   |                        |
|  | 30   | 42           | 100, 200 | Min Length: 6 in<br>Max Length (30ppm): 32 in<br>Max Length (60ppm): 22 in     | AL, Ind Welded   |                        |
|  |  |              |          |  | SST, Ind Welded  |                        |
|  |  |              |          |  | SST, Food Grade Welded   |                        |
|  | 30   | 48           | 100, 200 | Min Length: 6 in<br>Max Length (30ppm): 36.5 in<br>Max of 54ppm                | AL, Ind Welded   |                        |
|  |  |              |          |  | SST, Ind Welded  |                        |
|  |  |              |          |  | SST, Food Grade Welded   |                        |
|  | 30   | 54           | 100, 200 | Min Length: 6 in<br>Max Length (30ppm): 41.5 in<br>Max of 48ppm                | AL, Ind Welded   |                        |
|  |  |              |          |  | SST, Ind Welded  |                        |
|  |  |              |          |  | SST, Food Grade Welded   |                        |
|  | 30   | 60           | 100, 200 | Min Length: 6 in<br>Max Length (30ppm): 46 in<br>Max of 44ppm                  | AL, Ind Welded   |                        |
|  |  |              |          |  | SST, Ind Welded  |                        |
|  |  |              |          |  | SST, Food Grade Welded   |                        |
|  | Checkweigher with Linear Thrust Reject Device (Includes: Infeed, scale, and outfeed conveyors. All conveyors same length.) | 30           | 36       | 100, 200   | Min Length: 6 in<br>Max Length (35ppm): 25.5 in<br>Max Length (70ppm): 15.5 in | AL, Ind Welded         |
|  |  |              |          |  |  | SST, Ind Welded        |
|  |  |              |          |  |  | SST, Food Grade Welded |
| 30   |  | 42           | 100, 200 | Min Length: 6 in<br>Max Length (30ppm): 32 in<br>Max Length (60ppm): 22 in     | AL, Ind Welded   |                        |
|  |  |              |          |  | SST, Ind Welded  |                        |
|  |  |              |          |  | SST, Food Grade Welded   |                        |
| 30   |  | 48           | 100, 200 | Min Length: 6 in<br>Max Length (30ppm): 36.5 in<br>Max of 54ppm                | AL, Ind Welded   |                        |
|  |  |              |          |  | SST, Ind Welded  |                        |
|  |  |              |          |  | SST, Food Grade Welded   |                        |
| 30   |  | 54           | 100, 200 | Min Length: 6 in<br>Max Length (30ppm): 41.5 in<br>Max of 48ppm                | AL, Ind Welded   |                        |
|  |  |              |          |  | SST, Ind Welded  |                        |
|  |  |              |          |  | SST, Food Grade Welded   |                        |
| 30   |  | 60           | 100, 200 | Min Length: 6 in<br>Max Length (30ppm): 46 in<br>Max of 44ppm                  | AL, Ind Welded   |                        |
|  |  |              |          |  | SST, Ind Welded  |                        |
|  |  |              |          |  | SST, Food Grade Welded   |                        |

IN-MOTION WEIGHING

# MotoWeigh® IMW

In-Motion Conveyor Scale and Checkweigher

Example Conveyor System Sizes and Configurations

| Configuration          | Scale Width  | Scale Length | Capacity | PPM  | Material   |
|------------------------|--|--------------|----------|--|--|
| Scale Conveyor Only    | 36   | 42           | 100, 200 | Min Length: 6 in<br>Max Length (30ppm): 32 in<br>Max Length (60ppm): 22 in | AL, Ind Welded   |
|                        |  |              |          |  | SST, Ind Welded  |
|                        |  |              |          |  | SST, Food Grade Welded   |
|                        | 36   | 48           | 100, 200 | Min Length: 6 in<br>Max Length (30ppm): 36.5 in<br>Max of 54ppm            | AL, Ind Welded   |
|                        |  |              |          |  | SST, Ind Welded  |
|                        |  |              |          |  | SST, Food Grade Welded   |
|                        | 36   | 54           | 100, 200 | Min Length: 6 in<br>Max Length (30ppm): 41.5 in<br>Max of 48ppm            | AL, Ind Welded   |
|                        |  |              |          |  | SST, Ind Welded  |
|                        | 36   | 60           | 100, 200 | Min Length: 6 in<br>Max Length (30ppm): 46 in<br>Max of 44ppm              | SST, Food Grade Welded   |
|                        |  |              |          |  | AL, Ind Welded   |
|                        |  |              |          |  | SST, Ind Welded  |
|                        | Checkweigher with Linear Thrust Reject Device (Includes: Infeed, scale, and outfeed conveyors. All conveyors same length.) | 36           | 42       | 100, 200   | Min Length: 6 in<br>Max Length (30ppm): 32 in<br>Max Length (60ppm): 22 in |
| SST, Ind Welded        |  |              |          |  |  |
| SST, Food Grade Welded |  |              |          |  |  |
| 36                     |  | 48           | 100, 200 | Min Length: 6 in<br>Max Length (30ppm): 36.5 in<br>Max of 54ppm            | AL, Ind Welded   |
|                        |  |              |          |  | SST, Ind Welded  |
|                        |  |              |          |  | SST, Food Grade Welded   |
| 36                     |  | 54           | 100, 200 | Min Length: 6 in<br>Max Length (30ppm): 41.5 in<br>Max of 48ppm            | AL, Ind Welded   |
|                        |  |              |          |  | SST, Ind Welded  |
| 36                     |  | 60           | 100, 200 | Min Length: 6 in<br>Max Length (30ppm): 46 in<br>Max of 44ppm              | SST, Food Grade Welded   |
|                        |  |              |          |  | AL, Ind Welded   |
|                        |  |              |          |  | SST, Ind Welded  |

Additional configurations, sizes, and capacities are available upon request

IN-MOTION WEIGHING



Diverter

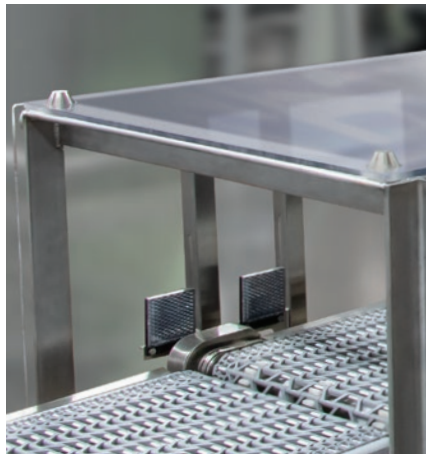

Draftshield



Stack light accessory

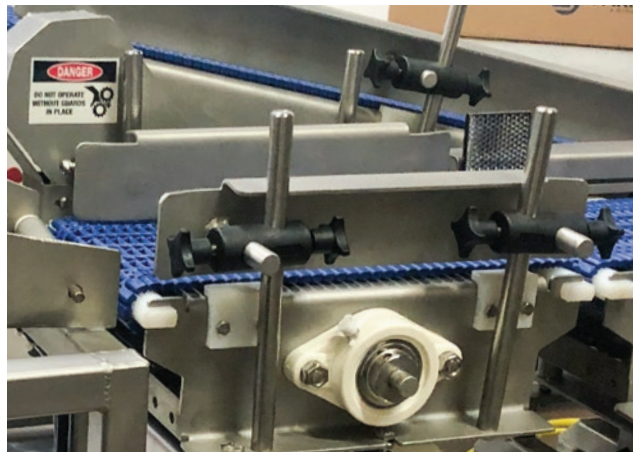

Guide rails