

Onboard Weighing

TABLE OF CONTENTS

Onboard Weighing.....	761
PL Series Load Cells.....	762
PL9110	764
<i>Mount Assembly</i>	
PLSB-25K Stacking Cone and Twist Lock	764
<i>Mount Assembly</i>	
Rigid Underbody Load Cell Kits	765
Tractor-trailer Kits	766
Loadrunner®	767
<i>Dump Truck Systems Kit</i>	
King Pin Load Cell Kit	768
Sand Shoe Load Cell Kit	768
TradeRoute® HL Series	769
<i>Legal for Trade Onboard Weighing System</i>	

Product names, logos, brands and other trademarks featured or referred to within this publication are the property of their respective trademark holders.

PL Series Load Cells

PL9000-14



The PL9000-14 is a low-profile load cell designed for onboard weighing applications with limited height. With a single-piece bearing plate and an overall profile of only 2.4 inches, the PL9000-14 is ideal for applications with four- or six-point underbody mounts and body rest mounts.

Order Information

Picture is a representation of actual product

Load Rating	Part #	Est. Weight	Price	
Static 16,500 lb	Dynamic 10,000 lb	114322	19 lb	\$810.00

PL9000-14.4



The PL9000-14.4 is ideal for underbody and body rest mounts in four- or six-point system configurations. This load cell offers higher load ratings with a single-piece bearing plate and overall length of 14 inches.

Order Information

Picture is a representation of actual product

Load Rating	Part #	Est. Weight	Price	
Static 25,000 lb	Dynamic 12,500 lb	115345	18 lb	\$920.00

PL9000-22



The PL9000-22 is designed for underbody mounts and low-profile axle scales such as Rice Lake's AX3040. It has a 2.4 inch profile and is 22.6 inches long.

Order Information

Picture is a representation of actual product

Load Rating	Part #	Est. Weight	Price	
Static 30,000 lb	Dynamic 20,000 lb	111766	30 lb	\$1,170.00

PL9000-26



The PL9000-26 is a heavy-duty, shear beam load cell designed for king pin plates and underbody mounts. Available with either a single bearing plate or two separate bearing plates, the PL9000-26 has a 2.3 inch profile and is 26 inches long.

Order Information

Picture is a representation of actual product

Load Rating	Part #	Est. Weight	Price	
Static 40,000 lb	Dynamic 20,000 lb	114325	35 lb	\$1,095.00

PL9000-50



The PL9000-50 is designed for fifth wheel kits and spring suspension equalizer hangers. The PL9000-50 has two separate bearing plates, one on each end, and an overall profile of 2.8 inches.

Order Information

Picture is a representation of actual product

Load Rating	Part #	Est. Weight	Price	
Static 50,000 lb	Dynamic 12,500 lb	114326	24 lb	\$925.00

PL9110



The PL9110 double-ended shear beam load cell is ideal for weighing equipment typically fixed to a truck body. This low-profile, rigid mount load cell is offered in capacities from 2,000 lb to 20,000 lb with the same profile.

Order Information

Picture is a representation of actual product

Load Rating	Part #	Est. Weight	Price
Static 2,000 lb	204610	6 lb	\$780.00
Static 5,000 lb	204611	6 lb	\$780.00
Static 10,000 lb	204612	6 lb	\$780.00
Static 20,000 lb	204613	6 lb	\$780.00

PL Series Load Cells

PL9200



The PL9200 onboard weighing load cell is hermetically sealed with an IP69 rating.

Order Information

Picture is a representation of actual product

Load Rating	Part #	Est. Weight	Price
Static 25,000 lb	209603	25 lb	\$1,195.00
Static 35,000 lb	210812	25 lb	\$1,195.00

RLD-10K



The RLD-10K double-ended shear beam load cell has a low profile and rigid mount. The RLD-10K is ideal for applications where suspension mounts are not suitable, profile increases don't work, or dynamic forces are present.

Order Information

Picture is a representation of actual product

Load Rating	Part #	Est. Weight	Price
Static 10,000 lb	120959	6 lb	\$1,260.00

PLSB-25K



The PLSB-25K is used in Rice Lake's twist-lock and stacking cone mount assemblies. This rigid mount, double-ended shear beam load cell is used when a series of mounts are not fixed to a frame at all times. The PLSB-25K can also be used in applications with dynamic forces.

Order Information

Picture is a representation of actual product

Load Rating	Part #	Est. Weight	Price
Static 25,000 lb	179827	26 lb	\$1,250.00
Static 25,000 lb	191898	26 lb	\$1,320.00

PLSB-40K



The PLSB-40K alloy steel load cell is hermetically sealed with an IP68 rating and has a 0.75 mV/V output at 12,500 lb.

Order Information

Picture is a representation of actual product

Load Rating	Part #	Est. Weight	Price
Static 40,000 lbs	117666	31 lb	\$1,075.00

LOAD PIN - 2 INCH, 20K



This 2-inch load pin is used in Rice Lake's Loadrunner kits and semi trailer landing gear. This load pin can be paired with load and support collars for applications that have pivot or rotation requirements.

Order Information

Picture is a representation of actual product

Load Rating	Part #	Est. Weight	Price
Static 20,000 lb	181895	10 lb	\$1,050.00

Additional details and complete specifications for onboard weighing load cells can be found online. Please consult the factory to determine the best model for your application.

ONBOARD WEIGHING

PL9110

Mount Assembly

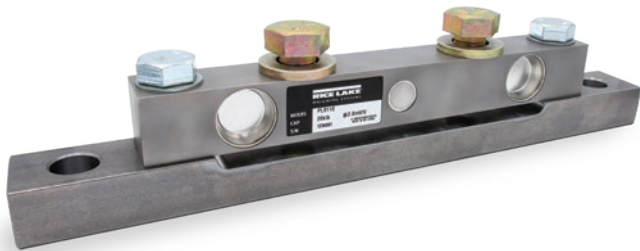

The PL9110 double-ended shear beam load cell is ideal for weighing equipment that is typically fixed to a truck body. This has a single-piece bearing plate, which offers both a low profile and rigid mounting. With capacities from 2,000 to 20,000 lb, the PL9110 is easy to integrate on any type of equipment.

Complete Kit Includes

- PL9110 stainless steel load cell
- Bearing plate (mild steel)
- Load cell bolts and spherical washers
- Upper mount bolts and flat washers

Standard Features

- Capacities from 2,000 to 20,000 lb (per module)
- IP68 rated load cell
- Single-piece bearing plate, allowance to bolt or welded into position
- All capacities maintain the same dimensions
- Spherical washer securement for load cell
- Rigid securement of equipment
- Low profile (2.25 in)
- Stainless steel module available upon request

Part Number/Price

Part #	Description	Price
208297	Kit, OnBoard PL9110-2K (single module kit)	\$960.00
208299	Kit, OnBoard PL9110-5K (single module kit)	\$960.00
208300	Kit, OnBoard PL9110-10K (single module kit)	\$960.00
208301	Kit, OnBoard PL9110-20K (single module kit)	\$960.00

ONBOARD WEIGHING

PLSB-25K Stacking Cone and Twist Lock

Mount Assembly

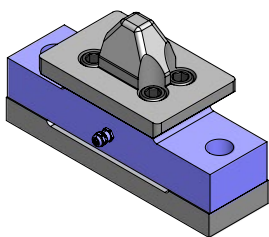

Stacking Cone Plate

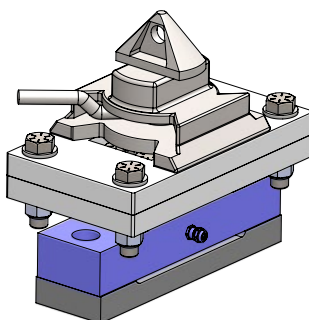

Twist Lock

The Twist Lock and Stacking Cone modules are designed for use with corner castings. Corner castings are the most common on intermodal containers, but can also be found integrated into other equipment. The low-profile, rigid mount PLSB-25K double-ended shear beam load cell is the heart of these modules.

Complete Kit Includes

- PLSB-25K load cell
- Bearing plate (mild steel)
- Functional Twist Lock or Stacking Cone upper assembly
- Intermediate plate (Twist Lock only)
- Hardware to secure the upper assembly to the load cell

Standard Features

- 25,000 lb capacity per module
- 50 ft cable lengths
- Single-piece bearing plate, through-hole mounting
- Rigid securement for upper assembly

Part Number/Price

Part #	Description	Price
190901	Kit, Onboard, TwistLock (single module kit)	\$2,250.00
188542	Kit, OnBoard, Stacking Cone (single module kit)	\$1,875.00

Rigid Underbody Load Cell Kits



Rice Lake Weighing Systems' rigid underbody load cell kits are designed to offer an onboard weighing solution for a variety of truck body types. They are mounted between the truck chassis and the body, needing little clearance to record weight information. These kits are common for straight truck applications with tanks and hoppers.

Part Number/Price

Part #	Model #	Description	Price
114307	PL9710-414.4	Four-point indicator kit with 14.4 in load cells (50,000 lb max with dead load) Kit includes: 9710, four-lead transmitter, (4) 14.4 in load cell, (4) bearing plates, (4) body coil springs, 35 ft truck cable, 15 ft power cable	\$6,800.00
114308	PL9710-614.4	Six-point indicator kit with 14.4 in load cells (75,000 lb max with dead load) Kit includes: 9710, six-lead transmitter, (6) 14.4 in load cell, (6) bearing plates, (8) body coil springs, anti rotation plate, 35 ft truck cable, 15 ft power cable	\$8,820.00

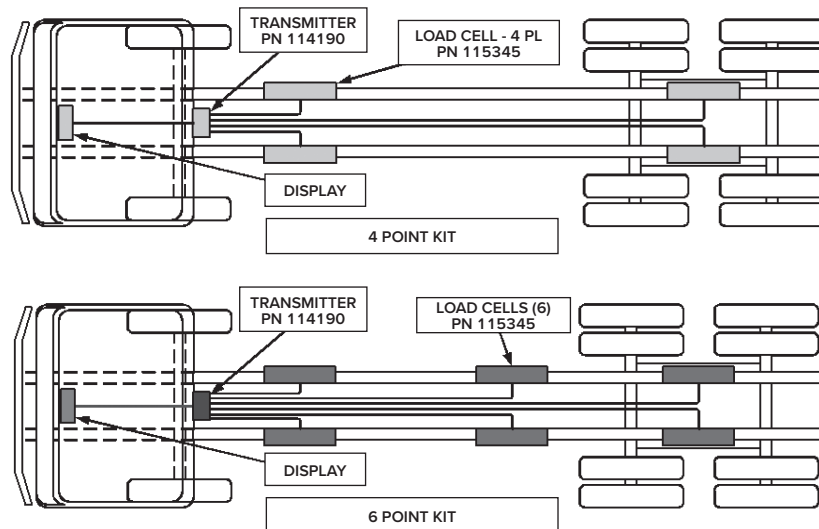

9700 Series Indicator, PN 114186



PL9000-14.4 Load Cell, PN 115345

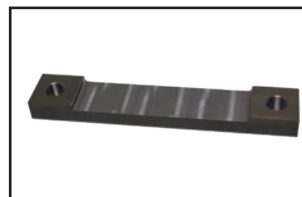

Bearing Plate, PN 115309



Transmitter, PN 114190



Transmitter, PN 114354



Cable Assembly, PN 114199



Power Cable, PN 115093

ONBOARD WEIGHING

Tractor-trailer Kits



Rice Lake Weighing Systems offers an array of onboard scale systems for over-the-road tractor-trailers. Whether you are adding air pressure or load cell sensing, many combinations are available to fit your needs.

Part Number/Price

Part #	Model #	Description	Price
Air Ride Kit, Tractor/Trailer			
114286	PL9700-200	Dual transducer kit (tractor-trailer) Kit includes: 9700, (2) air transmitter 2-lead, (2) dual air pressure transducer, 35 ft & 80 ft truck cable, 15 ft power cable	\$3,880.00
Fifthwheel Kit w/Air Ride Trailer Kit			
114295	PL9701-250H	Holland fixed fifth wheel kit (25,000 lb max with dead load) Kit includes: 9700, dual lead transmitter, (2) fifth wheel bending beam/suspension load cell, 35 ft truck cable, 15 ft power cable, hardware	\$4,620.00
114294	PL9701-200	Dual transducer kit (trailer only) Kit includes: Air transmitter 2-lead LC, dual air pressure transducer, 80 ft truck cable	\$1,360.00

ONBOARD WEIGHING

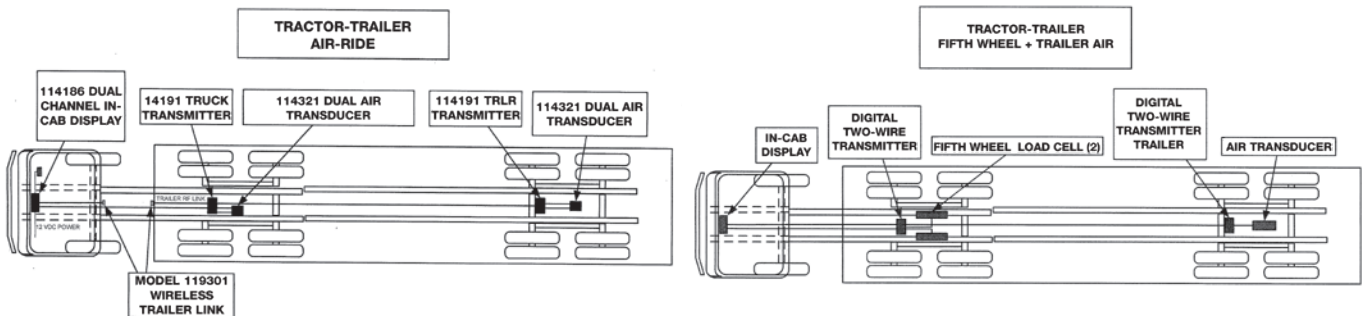

9700 Series Indicator, PN 114186



Air Pressure Transducer, PN 114321



Transmitter, PN 114191



Cable Assembly, PN 114199



Trailer Cable, PN 114201



Power Cable, PN 115093

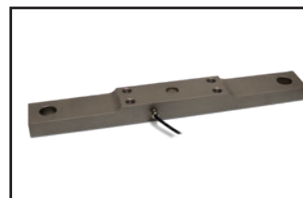

PL9000-50 Load Cell, PN 114326



Trunnion, Holland, PN 115104



Rice Lake Weighing Systems' onboard scale systems ensure optimal and safe use of a truck's payload capacity. The Loadrunner dump truck system incorporates both load cell and hydraulic pressure sensing. Weight information is obtained when the dump body is lifted a few inches off the frame.

Part Number/Price

Part #	Description	Price
System		
158195	Dump truck system with 2-in load pins, indicator, cables and hardware	\$5,200.00

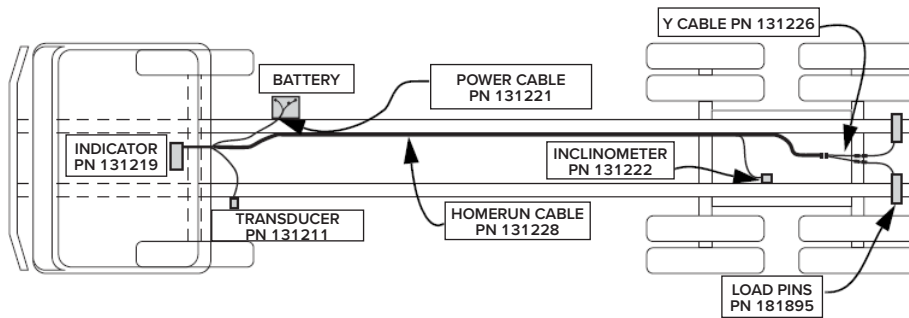

ONBOARD WEIGHING



OB-350 Indicator, PN 131219



Hydraulic Transducer, PN 131211



Dump Truck Load Pin, PN 181895



Onboard Inclinator, PN 131222

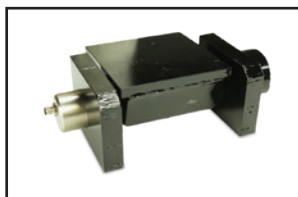

Dump Truck Hardware Kit



Power Cable, PN 131221



Y-Splitter Cable, PN 131226



Homerun Cable, PN 131228

Compatibility note: The Loadrunner dump truck kit has been designed for use on dual pin hinge pivot type dump bodies only. For dump truck body rear pivot assemblies using a single hinge bar, contact Rice Lake.

King Pin Load Cell Kit

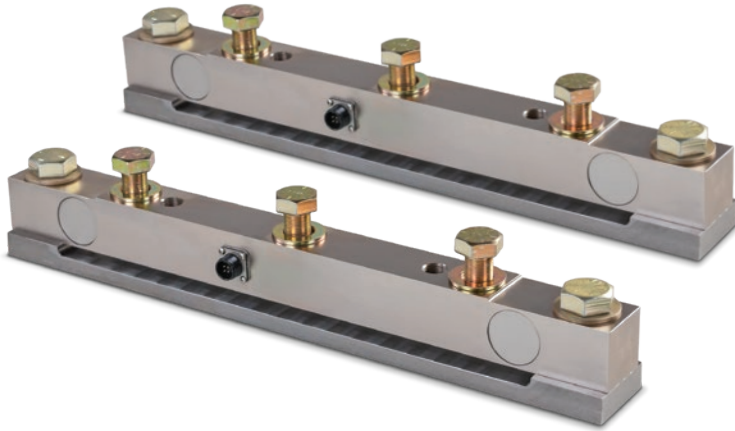

The PL9000-26 is a double-ended shear beam load cell that is ideal for distributing weight of the king pin plate to the trailer frame. With a capacity of 20,000 lb per module, these load cells can withstand rough roads.

Complete Kit Includes

- Two PL9000-26 load cells
- Two bearing plates (mild steel)
- Two 30 ft cables with connectors
- Load cell bolts and flat washers
- Upper mount bolts and flat washers

Standard Features

- System capacity:
 - Dynamic: 40,000 lb
 - Static: 80,000 lb
- Four-pin load cell connectors
- Connector cable assembly with potted connectors
- Single-piece bearing plate, welded securement
- Rigid mounting of load cell to frame (king pin plate not included)

Part Number/Price

Part #	Description	Price
171325	Onboard kit, king pin plate load cell system	\$3,200.00

*King pin plate not included with kit

ONBOARD WEIGHING

Sand Shoe Load Cell Kit

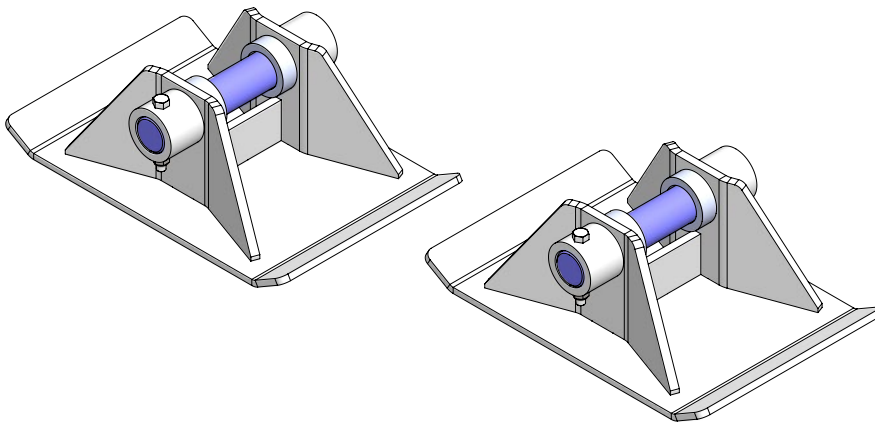

The sand shoe load cell kit is a conversion for common semi-trailer landing gear. A pair of load cells with a 2-in diameter and 20,000 lb capacity install in place of the original sand shoe pins. Complimenting sand shoes are included to distribute the force to the load cells properly.

Complete Kit Includes

- Two 2-in, 20,000 lb load cell pins
- Two sand shoes
- Four load distribution spacers
- Two bolts for anti-rotation of load cell

Standard Features

- System capacity: 40,000 lb
- Load cell with connectors, M12
- 20 × 13 ft heavy-duty painted sand shoe

Part Number/Price

Part #	Description	Price
215049	Onboard Kit, sand shoe load cell system	\$4,600.00

TradeRoute® HL Series

Legal for Trade Onboard Weighing System



Double-double Assembly

Approvals



Measurement
Canada
Approved



Single Assembly



Double Assembly

Standard Features

System Includes

- Three- or four-point onboard system, RL20000 load cell
- 80 ft conduit cable
- Magnetic transport alarm sensor with 15 ft of cable
- JB4SS junction box
- Hydraulic line locks and hoses
- 920i® Onboard Weigh Center
- Hydraulic pump not included
- Minimum 3,000 PSI recommended to maintain 2,200 PSI during lift

920i Onboard Weigh Center

- Epson® TM-U295 printer with splash shield
- Pre-installed 30 ft power cable, 30 ft home run cable and inclinometer
- Transport alarm LEDs
- Power switch
- Start/stop switch
- Waterproof enclosure
- Vibration mounts
- Mounting bracket to body not included

920i USB Universal with Onboard Software

- RS-232 port for connecting to ticket printer
- Standard onboard software
- USB interface board only

USB Interface Functions

- USB interface card on Port 2
- Supports weigh mode and configuration mode functions
- Supports upload of databases and 920i configuration file
- Supports download of databases, 920i configuration file, iRite®, COD file and firmware file
- Sanity checks for command errors
- Create standard database files
- Type A sealed connection available upon request

Flash Drives

- Supports USB 2.0 (optional)
- Create subdirectories by unit ID and database name
- Uses the root directory for generic files

Specifications

Capacity:

Up to 60,000 lb (30,000 kg)

Load Cell:

RL 20000I S-beam alloy steel, 20 ft cable, IP67

Junction Box:

JB4SS TuffSeal®

Rating/Material:

NEMA Type 4X
Stainless steel enclosure

Power Input:

9 to 36 VDC

Weigh Center:

920i® series weight controller
Epson® TM-U295

Approvals:

NTEP 15-102 Class III/IIIL
Measurement Canada AM-4847

ONBOARD WEIGHING

TradeRoute® HL Series

Legal for Trade Onboard Weighing System

Part Number/Price

Part #	Model #	Description	Price
TradeRoute Package (Includes 920i Weigh Center)			
131098	AN15L-3	15,000 lb × 5 lb/8,000 kg × 2 kg 3-point system, OB5-SGL5 / OB10-DBL5 modules	\$15,400.00
131099	AN20L-4	20,000 lb × 5 lb/10,000 kg × 2 kg 4-point system, OB10-DBL5 (× 2) modules	\$18,200.00
131100	AN30L-3	30,000 lb × 10 lb/15,000 kg × 5 kg 3-point system, OB10-SGL10 / OB20-DBL10 modules	\$16,300.00
131101	AN40L-4	40,000 lb × 10 lb/20,000 kg × 5 kg 4-point system, OB20-DBL10 (× 2) modules	\$18,200.00
131103	AN60L-4	60,000 lb × 10 lb/30,000 kg × 5 kg 4-point system, OB30-DBL15 (× 2) modules	\$20,400.00
TradeRoute Package (Includes In-cab 920i, Alarm and Inclinator. Printer is not included)			
221327	AN15L-3	15,000 lb × 5 lb/8,000 kg × 2 kg 3-point system, OB5-SGL5 / OB10-DBL5 modules	\$14,900.00
221328	AN20L-4	20,000 lb × 5 lb/10,000 kg × 2 kg 4-point system, OB10-DBL5 (× 2) modules	\$17,700.00
221329	AN30L-3	30,000 lb × 10 lb/15,000 kg × 5 kg 3-point system, OB10-SGL10 / OB20-DBL10 modules	\$15,800.00
214818	AN40L-4	40,000 lb × 10 lb/20,000 kg × 5 kg 4-point system, OB20-DBL10 (× 2) modules	\$17,700.00
219104	AN60L-4	60,000 lb × 10 lb/30,000 kg × 5 kg 4-point system, OB30-DBL15 (× 2) modules	\$19,400.00
System Components			
131442	–	920i® Weigh Center package includes: Indicator, Epson® Ticket Printer, 25ft load cell cable, power cable, housing, vibration mounts for installation to customer supplied mounting bracket	\$5,350.00
154109	–	In-cab indicator 920i (requires 154112, 154111 and printer)	\$4,150.00
154112	–	In-cab LED alarm assembly, 8 ft cable	\$130.00
154111	–	Inclinometer, junction box assembly, 35 ft cable	\$750.00
65635	–	Epson TM-U295 printer	\$660.00
232439	–	Epson TM-U220II printer	\$495.00
131811	–	Optional LED cab alarm, 35 ft	\$150.00
15494	EL146HE	Four conductor hostile environment load cell cable	\$2.10/ft
88956	JB4SS	JB4SS signal trim j-box with PG37 cord grips	\$295.00
128123	–	Conduit, 1/2 in non metallic liquid tight polytuf®	\$12.00/ft
128670	OB5-SGL5	Low profile 5,000 lb single assembly	\$4,870.00
128666	OB10-DLB5	Low profile 10,000 lb double assembly	\$6,140.00
127956	OB10-SGL10	Low profile 10,000 lb single assembly	\$4,870.00
127958	OB20-DBL10	Low profile 20,000 lb double assembly	\$6,140.00
127959	OB30-DBL15	Low profile 30,000 lb double assembly	\$8,520.00
155300	OB30-TAN15	Low profile 30,000 lb single tandem assembly	\$10,320.00

Note: Connect to your existing hydraulic pump with a maximum pressure of 3,000 PSI with a minimum flow of 5 GPM for best performance of lifting speed.

Note: Contact factory for other capacities not shown.

ONBOARD WEIGHING