

# MSI TranSend™

*Wireless Load Cell Interface System  
Single and Multiple Channel Transmitters and Receivers*

## Technical Manual



**RICE LAKE**<sup>®</sup>  
WEIGHING SYSTEMS

© Rice Lake Weighing Systems. All rights reserved.

Rice Lake Weighing Systems® is a registered trademark of  
Rice Lake Weighing Systems.

All other brand or product names within this publication are trademarks or  
registered trademarks of their respective companies.

All information contained within this publication is, to the best of our knowledge, complete and  
accurate at the time of publication. Rice Lake Weighing Systems reserves the right to make  
changes to the technology, features, specifications and design of the equipment without notice.

The most current version of this publication, software, firmware and all other product  
updates can be found on our website:

[www.ricelake.com](http://www.ricelake.com)

# Revision History

---

This section tracks and describes manual revisions for awareness of major updates.

Revision	Date	Description
A	January 14, 2025	Release of Second Generation MSI-7000 and MSI-7000
B	June 17, 2026	Updated replacement parts

*Table i. Revision Letter History*



Technical training seminars are available through Rice Lake Weighing Systems. Course descriptions and dates can be viewed at [www.ricelake.com/training](http://www.ricelake.com/training) or obtained by calling 715-234-9171 and asking for the training department.

# Contents

<b>1.0</b>	<b>Introduction</b>	<b>7</b>
1.1	Overview	7
1.1.1	Transmitters	7
1.1.2	Receivers	7
1.2	Safety	8
1.3	Disposal	8
1.4	FCC Compliance	9
<b>2.0</b>	<b>MSI-7000 Installation</b>	<b>10</b>
2.1	Unpacking and Assembly	10
2.2	Getting Started	10
2.3	Mounting the Enclosure	10
2.4	MSI-7000 Front Panel	11
2.5	Opening and Resealing the Enclosure	12
2.5.1	Opening the Enclosure	12
2.5.2	Resealing the Enclosure	12
2.5.3	Legal for Trade	12
2.6	Wiring and Connections	13
2.6.1	Load Cell Cables	14
2.6.2	Power Supply	15
2.6.3	Relays	15
2.6.4	Serial Connections	16
2.7	ScaleCore Card Replacement	17
2.7.1	Expansion Board	17
2.8	Radio Module Replacement	19
2.9	Battery Replacement	20
<b>3.0</b>	<b>MSI-7001 Installation</b>	<b>21</b>
3.1	Unpacking and Assembly	21
3.2	Getting Started	21
3.3	Mounting the Enclosure	21
3.4	MSI-7001 Front Panel	22
3.5	Opening and Resealing the Enclosure	23
3.5.1	Opening the Enclosure	23
3.5.2	Resealing the Enclosure	23
3.5.3	Legal for Trade	23
3.6	Wiring and Connections	24
3.6.1	Load Cell Cables	25
3.6.2	Power Supply	26
3.6.3	Serial Connections	26
3.6.4	Expansion Board	27



Rice Lake continually offers web-based video training on a growing selection of product-related topics at no cost. Visit [www.ricelake.com/webinars](http://www.ricelake.com/webinars)

**4.0 Communication . . . . . 29**

4.1 Network Connections . . . . . 29

    4.1.1 802.15.4 Network . . . . . 29

    4.1.2 RF modem network . . . . . 29

4.2 Antenna Options . . . . . 30

4.3 Antenna Replacement . . . . . 31

**5.0 Optional Rugged Remote . . . . . 32**

5.1 Operation . . . . . 32

    5.1.1 Power . . . . . 33

    5.1.2 Zero . . . . . 33

    5.1.3 Tare . . . . . 33

    5.1.4 Programmable Function Keys . . . . . 33

**6.0 Replacement Parts . . . . . 34**

**7.0 Specifications . . . . . 38**



*Technical training seminars are available through Rice Lake Weighing Systems. Course descriptions and dates can be viewed at [www.ricelake.com/training](http://www.ricelake.com/training) or obtained by calling 715-234-9171 and asking for the training department.*



*Rice Lake continually offers web-based video training on a growing selection of product-related topics at no cost. Visit [www.ricelake.com/webinars](http://www.ricelake.com/webinars)*

# 1.0 Introduction

This manual is intended for use by service technicians responsible for installing and servicing the MSI-7000 TranSend and MSI-7001 TranSend. Configurations and calibration of the scale can be accomplished using ScaleCore Connect software, ScaleCore-based RF remote control devices or ScaleCore-based RF remote displays. The transmitters in the series can interface with any type of load cell.



Manuals are available from Rice Lake Weighing Systems at [www.ricelake.com/manuals](http://www.ricelake.com/manuals)

Warranty information is available at [www.ricelake.com/warranties](http://www.ricelake.com/warranties)

## 1.1 Overview

A single MSI TranSend 7000 Series transmitter or receiver can be used to communicate wirelessly with a ScaleCore-based remote display or indicator.

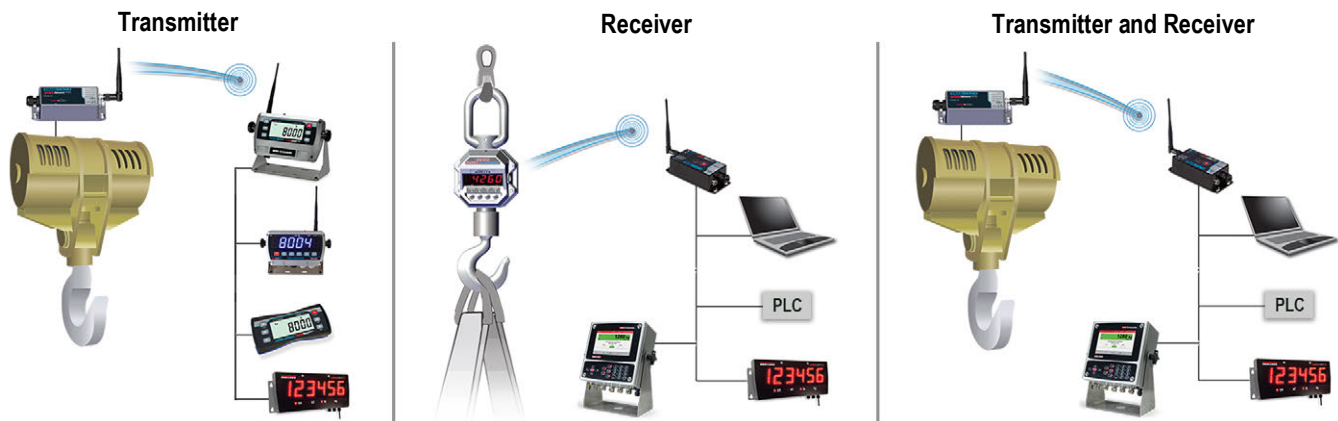

Figure 1-1. MSI TranSend 7000 Series

### 1.1.1 Transmitters

An MSI TranSend 7000 Series transmitter can be used to send weigh data wirelessly to an MSI TranSend 7000 Series receiver or a ScaleCore-based remote display. ScaleCore-based indicators can also be used as transmitters to send weigh data to either an MSI TranSend 7000 Series receiver or a ScaleCore-based remote display.

### 1.1.2 Receivers

An MSI TranSend 7000 Series receiver can be used to receive weigh data wirelessly from an MSI TranSend 7000 Series transmitter or a ScaleCore-based indicator. ScaleCore-based remote displays can also be used as receivers to receive weigh data from either an MSI TranSend 7000 Series transmitter or a ScaleCore-based indicator. All MSI receivers are compatible with all MSI transmitters, except for the receivers that provide an mV signal to a digital weight indicator.

## 1.2 Safety

### Safety Definitions:



**DANGER:** Indicates an imminently hazardous situation that, if not avoided, will result in death or serious injury. Includes hazards that are exposed when guards are removed.



**WARNING:** Indicates a potentially hazardous situation that, if not avoided, could result in serious injury or death. Includes hazards that are exposed when guards are removed.



**CAUTION:** Indicates a potentially hazardous situation that, if not avoided, could result in minor or moderate injury.



**IMPORTANT:** Indicates information about procedures that, if not observed, could result in damage to equipment or corruption to and loss of data.

### General Safety

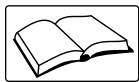

Do not operate or work on this equipment unless this manual has been read and all instructions are understood. Failure to follow the instructions or heed the warnings could result in injury or death. Contact any Rice Lake Weighing Systems dealer for replacement manuals.



#### WARNING

Failure to heed could result in serious injury or death.

Do not allow minors (children) or inexperienced persons to operate this unit.

Do not stand near a load being lifted as it is a potential falling hazard. Keep a safe distance.

Do not use for purposes other than weight taking or dynamic load monitoring.

Do not use any load bearing component that is worn beyond five percent of the original dimension.

Do not use any associated lifting product if any of the load bearing components are cracked, deformed or show signs of fatigue.

Do not exceed the rated load limit of the associated scale/dynamometer unit, rigging element or the lifting structure.

Do not allow multi-point contact with the hook, shackle or lifting eye of the associated scale/Dynamometer unit.

Do not allow high torque on the scale/dynamometer unless it is specifically designed for high torque.

Do not make alterations or modifications to the unit or associated load bearing devices; any alterations void the warranty.

Do not remove or obscure warning labels.

There are no user serviceable parts. Any repairs are to be performed by qualified service personnel only.



#### IMPORTANT

All included batteries intended for sale in the EU market are classified as “Portable Batteries for General Use” and comply with Regulation (EU) 2023/1542.

## 1.3 Disposal



### Product Disposal

The product must be brought to appropriate separate waste collection centers at the end of its life cycle.

Proper separate collection to recycle the product helps prevent possible negative effects on the environment and to health, and promotes the recycling of the materials. Users who dispose of the product illegally shall face administrative sanctions as provided by law.

### Battery Disposal

Dispose of batteries at appropriate waste collection centers at the end of their life cycle in accordance with local laws and regulations. Batteries and rechargeable batteries may contain harmful substances that should not be disposed of in household waste. Batteries may contain harmful substances including but not limited to: cadmium (Cd), lithium (Li), mercury (Hg) or lead (Pb). Users who dispose of batteries illegally shall face administrative sanctions as provided by law.



**WARNING:** Risk of fire and explosion. Do not burn, crush, disassemble or short-circuit lithium batteries.

## 1.4 FCC Compliance

### United States

This equipment has been tested and found to comply with the limits for a Class A digital device, pursuant to Part 15 of the FCC Rules. These limits are designed to provide reasonable protection against harmful interference when the equipment is operated in a commercial environment. This equipment generates, uses and can radiate radio frequency energy and, if not installed and used in accordance with the instruction manual, may cause harmful interference to radio communications. Operation of this equipment in a residential area is likely to cause harmful interference in which case the user will be required to correct the interference at his own expense.

### Canada

This digital apparatus does not exceed the Class A limits for radio noise emissions from digital apparatus set out in the Radio Interference Regulations of the Canadian Department of Communications.

Le présent appareil numérique n'émet pas de bruits radioélectriques dépassant les limites applicables aux appareils numériques de la Class A prescrites dans le Règlement sur le brouillage radioélectrique édicté par le ministère des Communications du Canada.

## 2.0 MSI-7000 Installation

This section describes procedures for connecting load cell and serial communications cables to the MSI-7000, along with instructions for mounting the enclosures.

### 2.1 Unpacking and Assembly

Remove the MSI-7000 unit from the packaging and inspect for visible damage. If damaged occurred during shipping, notify Rice Lake Weighing Systems and the shipper immediately.

Retain original packaging when possible, in the event that it needs to be returned, it must be properly packed with sufficient packing materials.

### 2.2 Getting Started

The MSI-7000 is often shipped pre-configured with a scale. If purchased separately, or to be used with a different system, the RF transceivers will have to be paired.

The system automatically connects with the scale once the RF setup is complete. A site survey is recommended to identify the RF Link's operating range and usability. Position the scale at an average operational height, and try the link at various positions and distances. The range may vary by the rotation of the scale/Dyna-Link, as well as the site and installation variables.

### 2.3 Mounting the Enclosure

The MSI-7000 can be mounted either vertically or horizontally to a flat surface.

If mounted inside an enclosure or I-beam, use the correct antenna for the environment and distance. Please call Rice Lake Weighing Systems, if assistance is needed to select an antenna, or reference the antenna selection guide in the appendix.



**NOTE:** Antennas must be placed within line-of-sight for reliable communications.



**IMPORTANT:** A standard antenna and coax connector are resistant to water, but not water-proof. Seal the TNC base with an adhesive heat shrink boot if antenna is exposed to water.

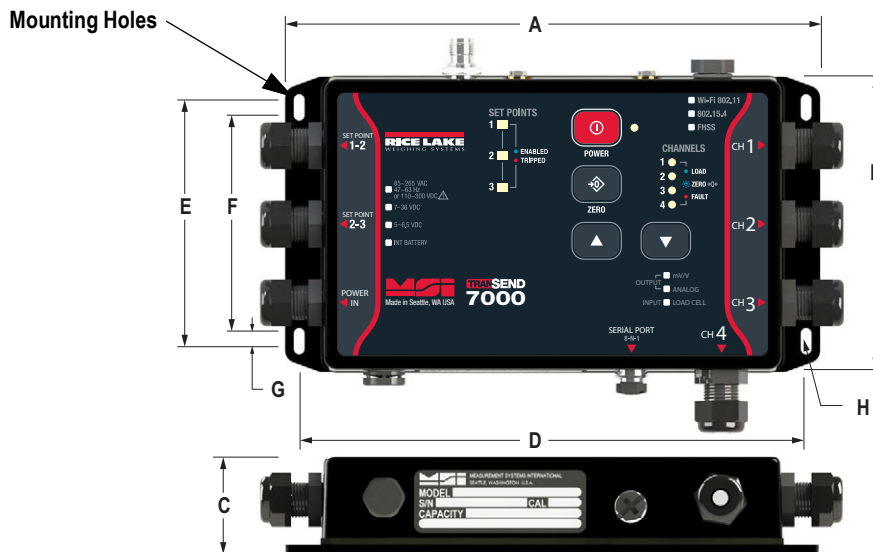

Figure 2-1. Mounting Dimensions – MSI-7000 TranSend

A	B	C	D	E	F	G	H
Overall Product Dimensions			Mounting Hole Center to Center Dimensions				
8.54 in (217.0 mm)	4.70 in (119.3 mm)	1.54 in (39.88 mm)	8.09 in (205.5 mm)	3.97 in (100.8 mm)	3.46 in (88.2 mm)	0.246 in (6.3 mm)	Top Ø 0.394 in (10.0 mm) Bottom Ø 0.167 in (4.2 mm)

Table 2-1. Dimensions – MSI-7000 TranSend

## 2.4 MSI-7000 Front Panel

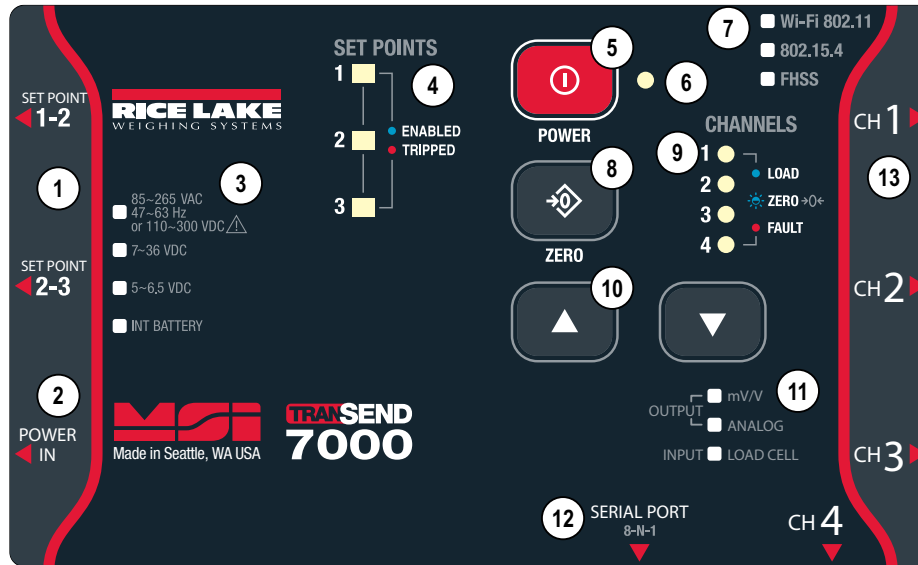

Figure 2-2. MSI-7000 Front Panel

Item No.	Description	
	Transmitter	Receiver
1	Setpoint 1-3 Connections – Located on the side of the unit	Setpoint 1-3 Connections – Located on the side of the unit
2	Power Input – Located on the side of the unit	Power Input – Located on the side of the unit
3	Type of Power Source – Type will be checked	Type of Power Source – Type will be checked
4	Setpoint LEDs Blue – Setpoint is enabled and not tripped Red – Setpoint is enabled and tripped	Setpoint LEDs Blue – Setpoint is enabled and not tripped Red – Setpoint is enabled and tripped
5	Power Button	Power Button
6	Power LED – Indicates unit is on when lit Steady Green – On with good battery (or AC) Steady Red – On with low battery Blinking Red – On with very low battery	Power LED – Indicates unit is on when lit Steady Green – On with good battery (or AC) Steady Red – On with low battery Blinking Red – On with very low battery
7	Wireless Options – Type is checked	Wireless Options – Type is checked
8	Zero Button – Press to zero the currently selected channel	Zero Button – Press to zero the currently selected channel
9	Channel LEDs – Indicates which channel is controlled by the unit Off – Sensor is disabled Steady Orange – Sensor fault (overload/underload/uncal/error/etc.) Blinking Blue – Sensor is in CoZ and working properly Steady Blue – Sensor is loaded and working properly Steady Purple – Sensor Selected (for two seconds)	Channel LEDs – Indicates which channel is controlled by the unit Off – Sensor is disabled Steady Orange – Sensor fault (overload/underload/uncal/error/etc.) Blinking Blue – Sensor is in CoZ and working properly Steady Blue – Sensor is loaded and working properly Steady Purple – Sensor Selected (for two seconds)
10	Arrow Buttons – Use to scroll through channels	Arrow Buttons – Use to scroll through channels
11	Output / Input – Type is checked	Output / Input – Type is checked
12	Serial Port – Located on the Bottom of unit; Pre-set at 9600 baud and 8-N-1	Serial Port – Located on the Bottom of unit; Pre-set at 9600 baud and 8-N-1
13	Load Cell Inputs – Located on the side of the unit	Load Cell Inputs – Located on the side of the unit

Table 2-2. MSI-7000 Front Panel Controls

## 2.5 Opening and Resealing the Enclosure

The enclosure must be opened to connect the load cell/sensor cables and other interface connections. The enclosure must be resealed to torque specifications to maintain IP rating.



**WARNING:** Before opening the unit, ensure the power is disconnected.

### 2.5.1 Opening the Enclosure

1. Place the MSI-7000 face down on an anti-static work mat.
2. Remove the screws securing the backplate to the enclosure with a phillips head screwdriver. Retain for re-installation.
3. Remove the backplate to access the interior and set it aside.

### 2.5.2 Resealing the Enclosure

1. Align enclosure gasket with the open lip of the enclosure
2. Replace lid of enclosure.
3. Replace enclosure screws with a phillips head screwdriver.
4. Torque screws to 5 in-lb.

### 2.5.3 Legal for Trade

The MSI-7000 can be sealed in legal for trade applications by placing a tamper proof sticker over an enclosure screw.

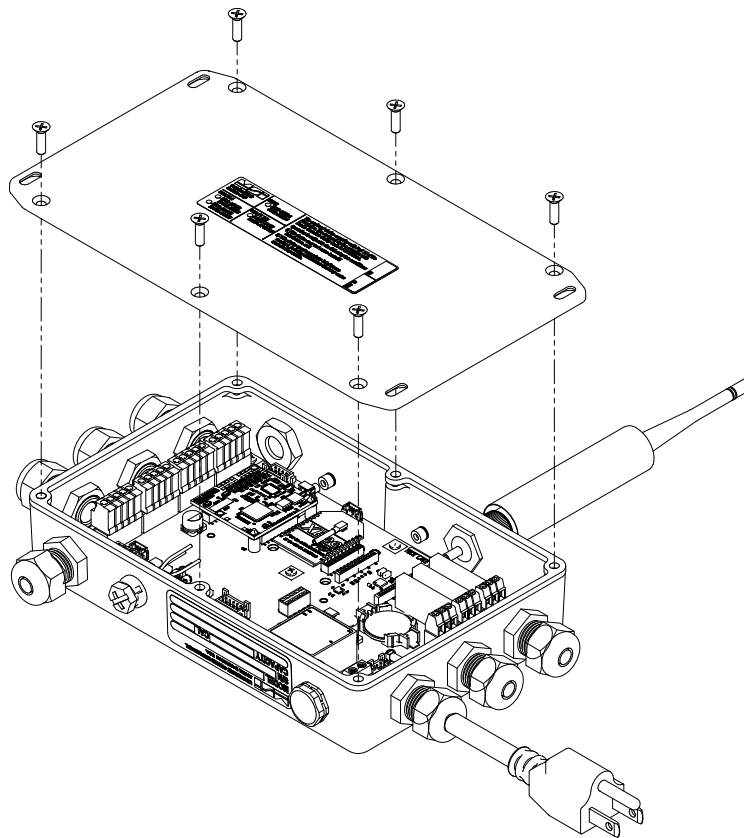

Figure 2-3. Opening and Closing the Enclosure

## 2.6 Wiring and Connections



**WARNING:** Before opening the unit, ensure the power is disconnected.

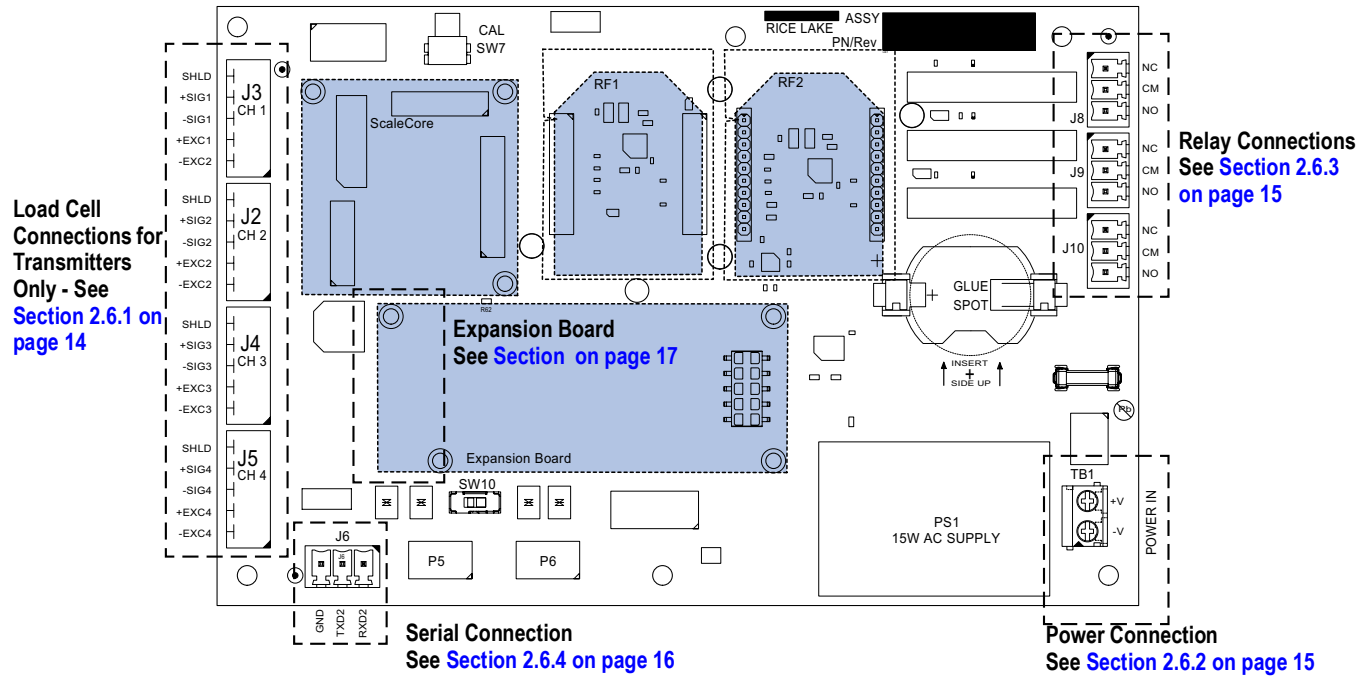

Figure 2-4. Connectors

### 2.6.1 Load Cell Cables

When using the MSI-7000 as a transmitter, connect the load cell cables to J2, J3, J4 and/or J5.

1. Remove backplate.
2. Loosen the cable connectors and remove the pin.
3. If connecting four load sensors, insert the two hole insert into the cable connectors.
4. Run load sensor cables through the cord grips into the indicator.
5. Loosen the screws in load sensor connector.
6. Insert stripped end of each wire into the holes of the connector.



**NOTE:** Terminal Blocks can be removed from the terminal block headers for easier load cell cable installation.

7. Re-tighten screws to secure wires.
8. Align the back plate on the enclosure and secure with screws.



**IMPORTANT:** The MSI-7000 must be calibrated once the load sensors have been connected.

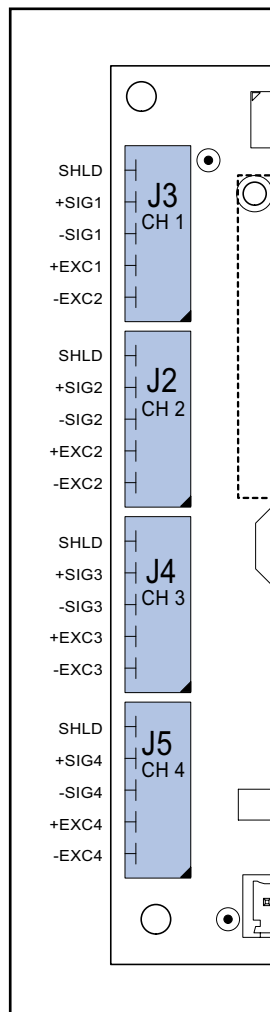



Figure 2-5. Load Cell to Terminal Block Connection



**NOTE:** In most applications it is not necessary to connect the shield to the j-box shield terminal. Sometimes noise pickup is improved by connecting the shield inside the j-box. However, it may make noise pickup worse. Test performance before cutting off the shield at the cable end.

## 2.6.2 Power Supply

 **WARNING:** Before opening the unit, ensure power is disconnected.

1. Remove backplate.
2. Loosen screws in the power wire connector to pull the wires from the connector.
3. Remove the screw securing the ground wire (AC Only).
4. Loosen the cable gland and pull the power cable from the enclosure.
5. Push new cable through the cable gland and reconnect wiring as shown below.
6. Ensure all connections are tight and reinstall the back plate.

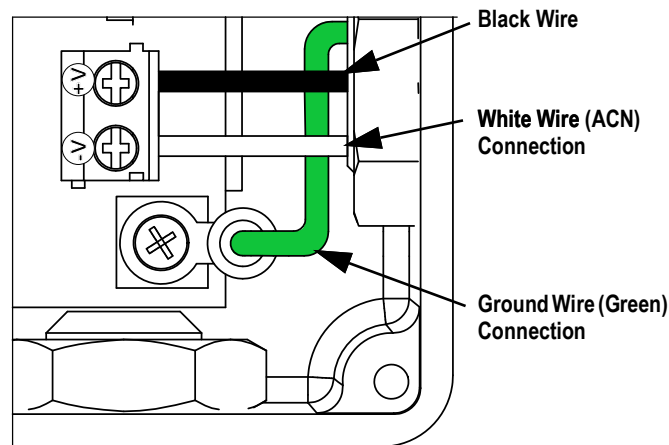

Figure 2-6. Power Supply

## 2.6.3 Relays

The MSI-7000 can be equipped with three Form C Coil relays for process control or safety related systems. Relays are installed and wired out to 3 pins on a M12 connector.

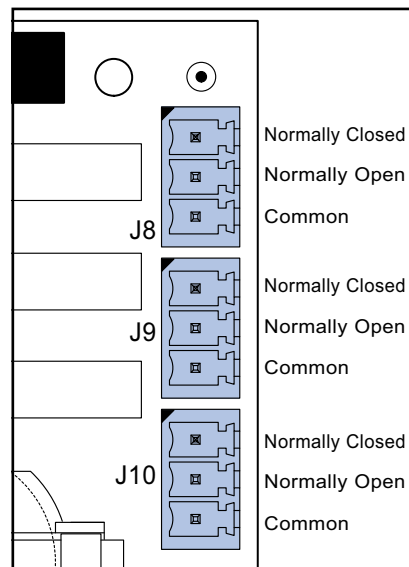

Figure 2-7. Relay Wiring Diagram

With normally open wiring, the contact is de-energized when the setpoint is inactive. When the setpoint is tripped, the contact closes and the relay energizes.

With normally closed wiring, the contact is closed and energized when the setpoint is inactive. When the setpoint is tripped, the contact opens and the relay de-energizes.

### 2.6.4 Serial Connections

Serial Communications defaults are set to:

- **Data Configuration:** The data output is fixed at 8-1-N.
- **Baud Rate:** Baud rate is not programmable. Serial port P6/RF2 is set at 38.4 k baud.
- **Handshaking:** No hardware handshaking is supported. Xon/Xoff software handshaking is always on.

Remove the back cover of the MSI-7000 to access the serial connectors and connect the cable.

The MSI-7000 has one serial comm port.

- Comm port 1, P5 is directly wired to the external Turck® serial connector. Comm port 1 is used for software updates, connecting to a remote display and for connecting to an RS-232 device.
- Comm Port 2 is connected to the RF 2 radio module.



**NOTE:** Serial Port P6 parallel to serial port J6. If unit is configured for 2 wired Turck connectors, the second Turck connector is wired to P6.

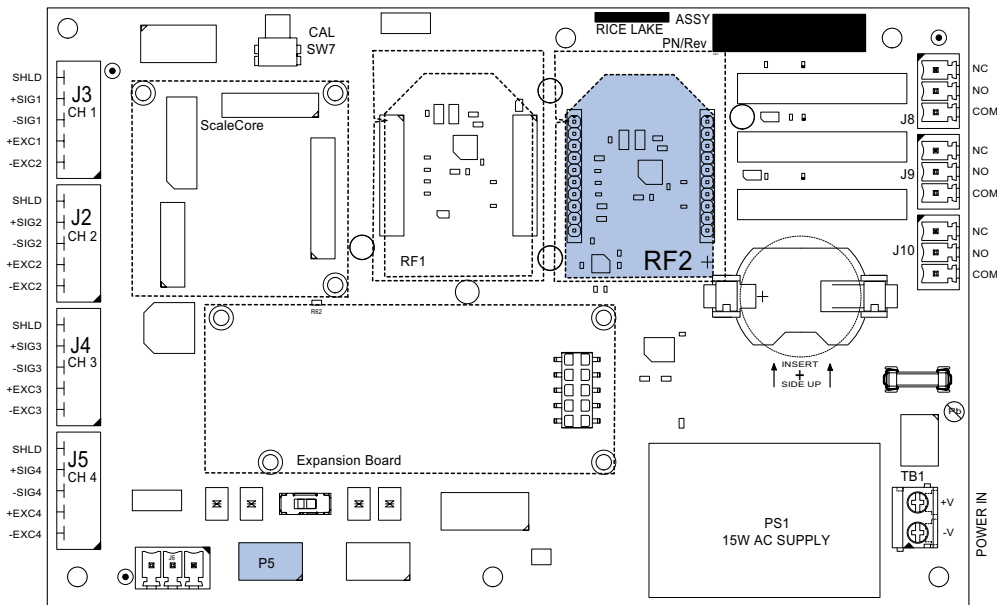

Figure 2-8. Connectors



**IMPORTANT:** Wire shield drain to the metal shell of the connector. Disconnect shield drain wire if ground loops cause unstable readings. If necessary use an isolated RS-232 interface.

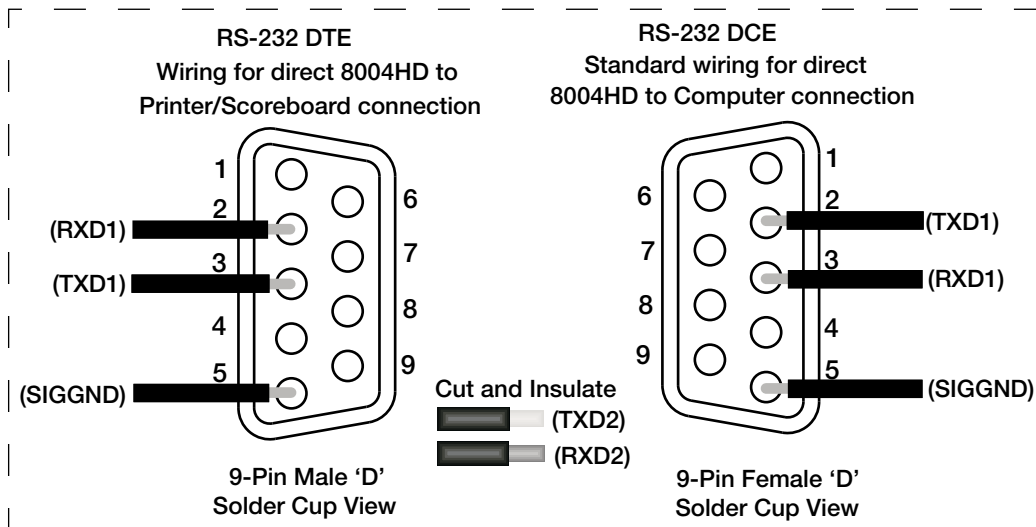

Figure 2-9. Communication Wiring

## 2.7 ScaleCore Card Replacement

1. Remove backplate (Section 2.5 on page 12).

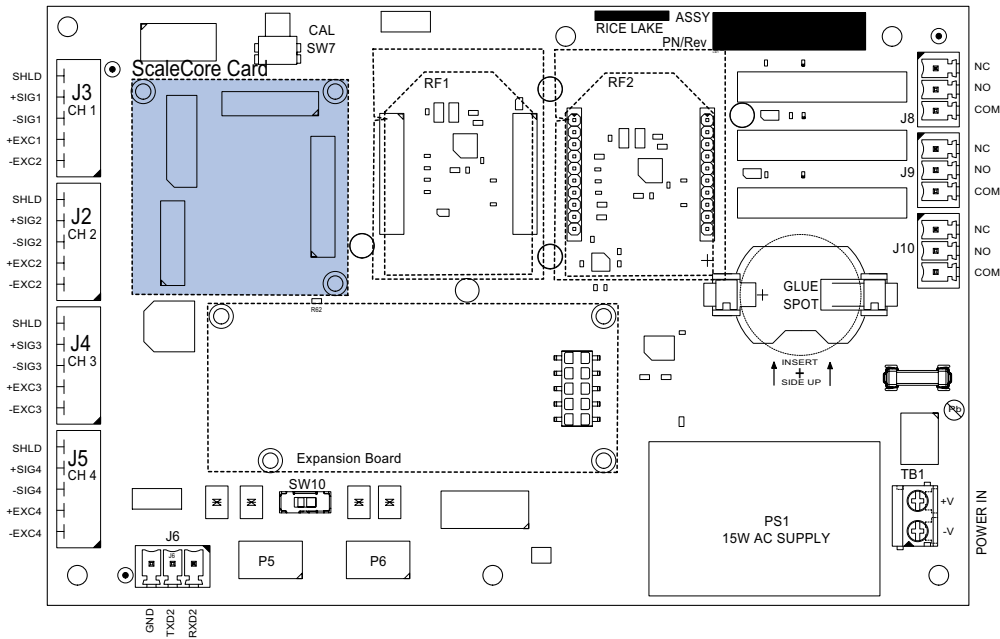

Figure 2-10. ScaleCore Card

2. Pull the ScaleCore card up to remove it.
3. Align the new card to the CPU board and standoffs.
4. Press firmly to secure the card in place.

### 2.7.1 Expansion Board

The Expansion Board slot allows for options to be added to the MSI-7000 product build.

#### Analog Output Connection

The Analog Output Option provides a means to connect the MSI-7000 to analog inputs found on PLCs and other industrial equipment. The optional Analog Output board allows one or two channels of the MSI-7000 to drive the Analog Outputs. See the ScaleCore Connect or ScaleCore Webserver Technical Manuals for more information on configuring analog output.

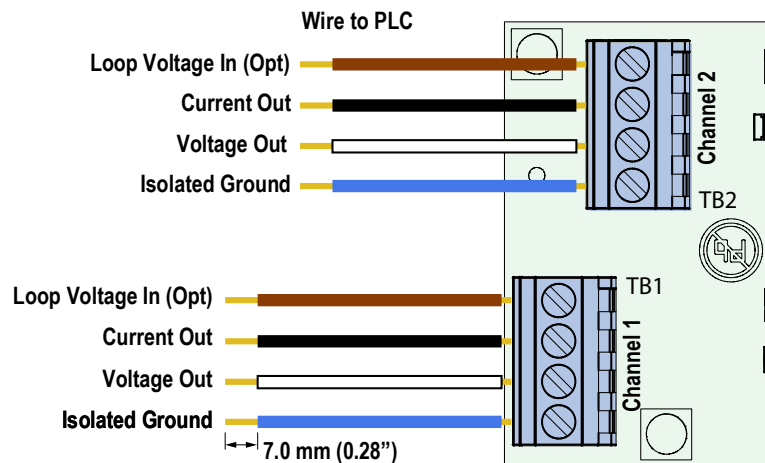

Figure 2-11. Analog Option Card

### PLC Wiring Diagrams

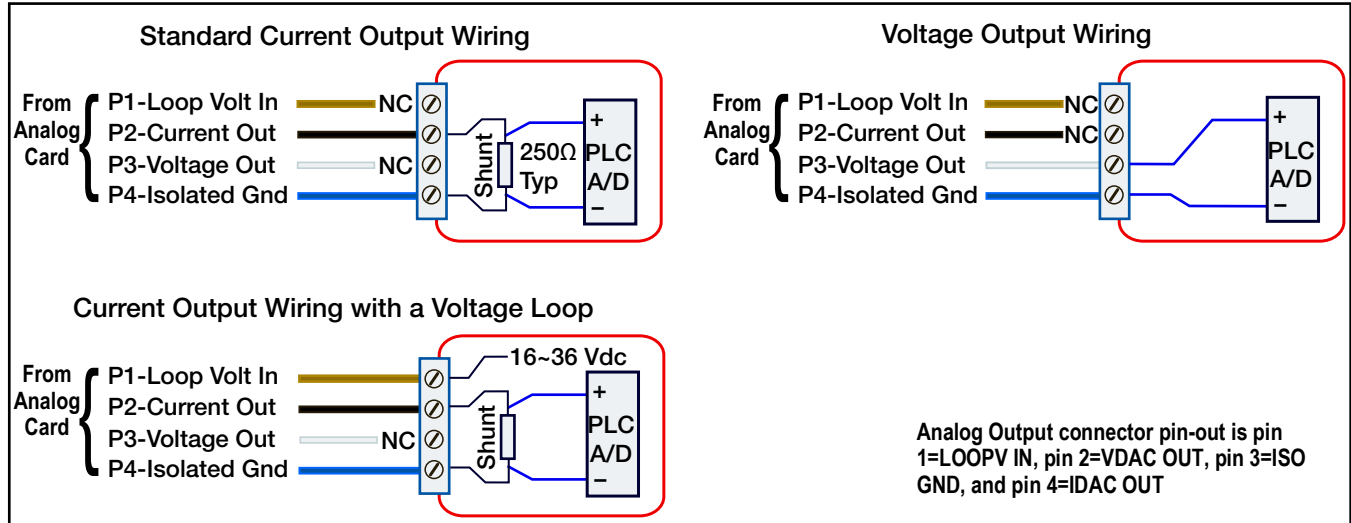

Figure 2-12. PLC Wiring

Pin #	Wire Color	Function	Comment
1	Brown	Loop Voltage In	Optional for increasing compliance. Input range: +16V to 36V max
2	Black	Current Out	Will drive 20mA into 625Ω without external boost voltage (See Table below)
3	White	Voltage Output	Specified for load resistance ≥1kΩ. Recommended load resistance: 100kΩ to minimize voltage drop due to wire resistance in connecting cable
4	Blue	Isolated Ground	Connection required for current and voltage output

Table 2-3. Analog Output Wiring

External Loop Voltage Input	20mA Output Max R <sub>wiring</sub> + R <sub>shunt</sub>	24mA Output Max R <sub>wiring</sub> + R <sub>shunt</sub>
None	625Ω	520Ω
18V	750Ω	625Ω
24V	1.05kΩ	875Ω
30V	1.35kΩ	1.125kΩ
36V	1.65kΩ	1.375kΩ

Table 2-4. Current Compliance Table

### Connecting Analog Output Cable to the Analog Output Connector

The MSI-8004HD connects to a PLC or other industrial equipment through the analog output cable. Connect the wires of the analog output cable to the analog output channels in [Figure 2-11 on page 17](#).

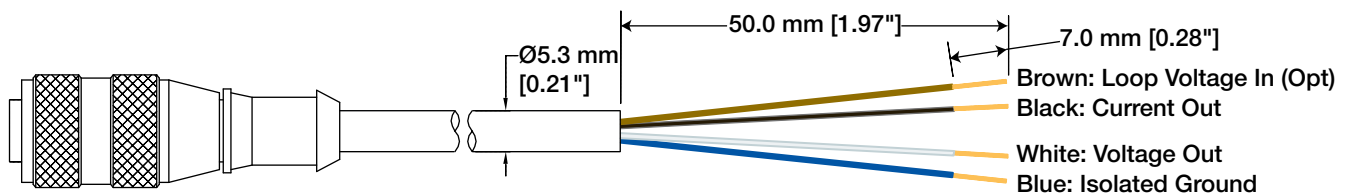

Figure 2-13. Analog Output Cable Wiring

## 2.8 Radio Module Replacement

The MSI-7000 can have two radio modules installed at a time. RF1 is programmed to be used with the Rugged Remote. RF2 can be 802.15.4, Wi-Fi, or FHSS. If ordered with the purchase of a system, radio modules will be installed and paired to the scale included in the order. Contact Rice Lake Weighing Systems or a local dealer to order separately or for more information.

1. Remove backplate (Section 2.5 on page 12).

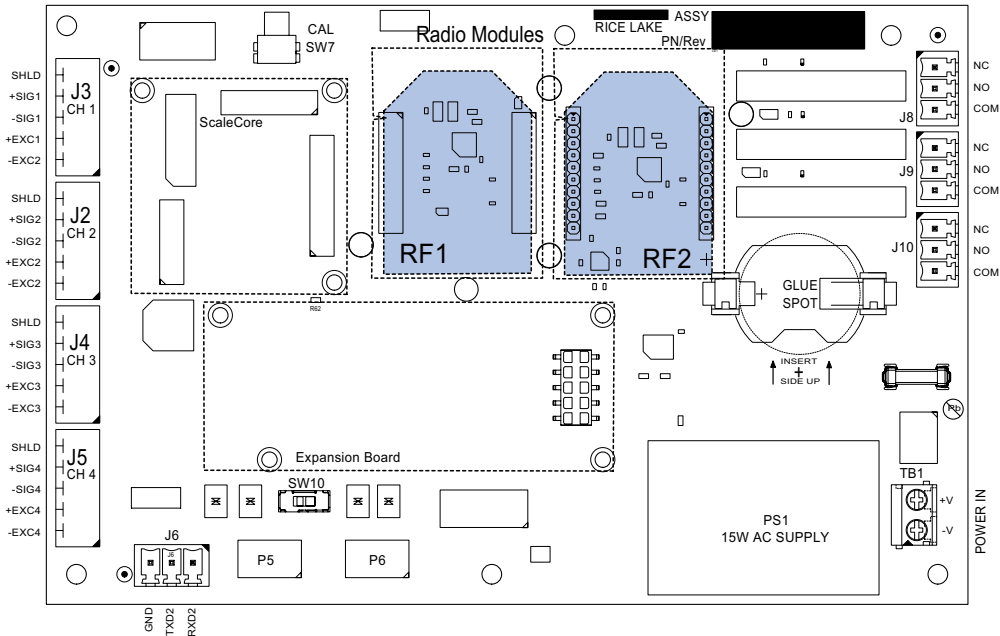

Figure 2-14. Radio Module

2. Disconnect the antenna wire from the radio module.
3. Pull card up to remove from the CPU Board.
4. Align new card with the connection. Ensure it is in line with the correct holes.
5. Press card into place and reconnect the antenna wire.



**NOTE:** The matching card must be installed in the attached scale. See the scale manual for instructions.

## 2.9 Battery Replacement

The MSI-7000 uses a rechargeable 3V lithium coin-cell battery as backup power to maintain the time and date when the indicator is disconnected from power. The battery life varies depending on use. It is recommended to replace the battery every three years, or sooner, if left powered off for extended periods of time to prevent data loss in the event of a power failure.



**WARNING:** Risk of explosion if battery is replaced with an incorrect type. Dispose of batteries at appropriate waste collection centers at the end of their life cycle in accordance with local laws and regulations. Batteries and rechargeable batteries may contain harmful substances that should not be disposed of in household waste. Batteries may contain harmful substances including but not limited to: cadmium (Cd), lithium (Li), mercury (Hg) or lead (Pb). Users who dispose of batteries illegally shall face administrative sanctions as provided by law.



**IMPORTANT:** Use anti-static protection for grounding and to protect components from electrostatic discharge (ESD) when working inside the 680 enclosure. Procedures requiring work inside the 680 must be performed by qualified service personnel only.

A Phillips head screwdriver is required for battery removal.

1. Disconnect power to the MSI-7000.
2. Remove Back Plate (See [Section 2.5.1 on page 12](#)).
3. Use a non-conductive tool to gently push the battery through the two access holes and out of the battery pocket.

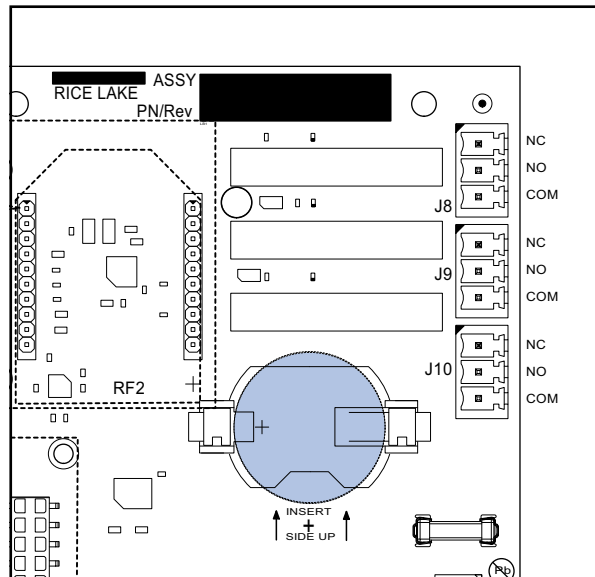

Figure 2-15. Battery Location

4. Fully slide the replacement coin-cell battery into the pocket using the same non-conductive tool.



**IMPORTANT:** Ensure the positive terminal of the battery is facing up. Incorrectly matching the battery terminals to the circuit can result in permanent damage to the device.

5. Replace back plate (See [Section 2.5.2 on page 12](#)).
6. Power the MSI-7000.

## 3.0 MSI-7001 Installation

This section describes procedures for connecting load cell and serial communications cables to the MSI-7001, along with instructions for mounting the enclosures.

### 3.1 Unpacking and Assembly

Remove the MSI-7001 unit from the packaging and inspect for visible damage. If damaged occurred during shipping, notify Rice Lake Weighing Systems and the shipper immediately.

Retain original packaging when possible, in the event that it needs to be returned, it must be properly packed with sufficient packing materials.

### 3.2 Getting Started

The MSI-7001 is often shipped pre-configured with a scale. If purchased separately, or to be used with a different system, the RF transceivers will have to be paired.

The system automatically connects with the scale once the RF setup is complete. A site survey is recommended to identify the RF Link's operating range and usability. Position the scale at an average operational height, and try the link at various positions and distances. The range may vary by the rotation of the scale/Dyna-Link, as well as the site and installation variables.

### 3.3 Mounting the Enclosure

The MSI-7001 can be mounted either vertically or horizontally to a flat surface.

If mounted inside an enclosure or I-beam, use the correct antenna for the environment and distance. Please call Rice Lake Weighing Systems, if assistance is needed to select an antenna, or reference the antenna selection guide in the appendix.



**NOTE:** Antennas must be placed within line-of-sight for reliable communications.



**IMPORTANT:** A standard antenna and coax connector are resistant to water, but not water-proof. Seal the TNC base with an adhesive heat shrink boot if antenna is exposed to water.

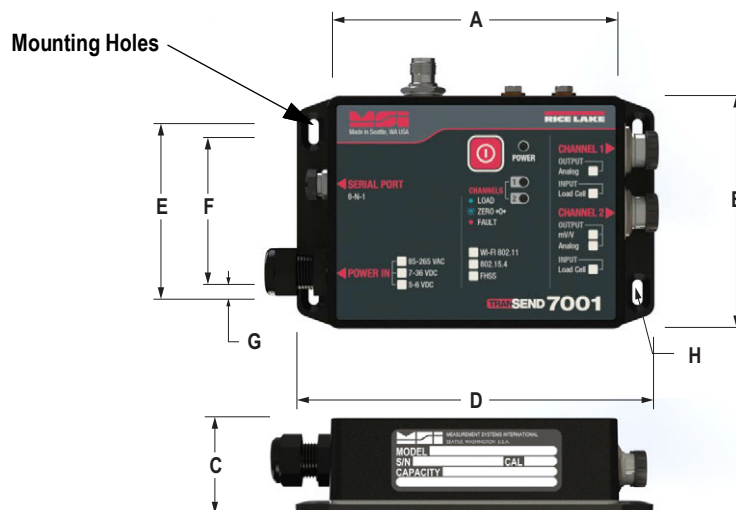

Figure 3-1. Mounting Dimensions – MSI-7001 TranSend

A	B	C	D	E	F	G	H
Overall Product Dimensions			Mounting Hole Center to Center Dimensions				
5.82 in (147.8 mm)	3.69 in (93.7 mm)	1.55 in (39.4 mm)	5.30 in (134.6 mm)	2.87 in (72.9 mm)	2.38 in (60.5 mm)	0.24 in (6.3 mm)	Top Ø 0.39 in (10.0 mm) Bottom Ø 0.16 in (4.2 mm)

Table 3-1. Dimensions – MSI-7001 TranSend

### 3.4 MSI-7001 Front Panel

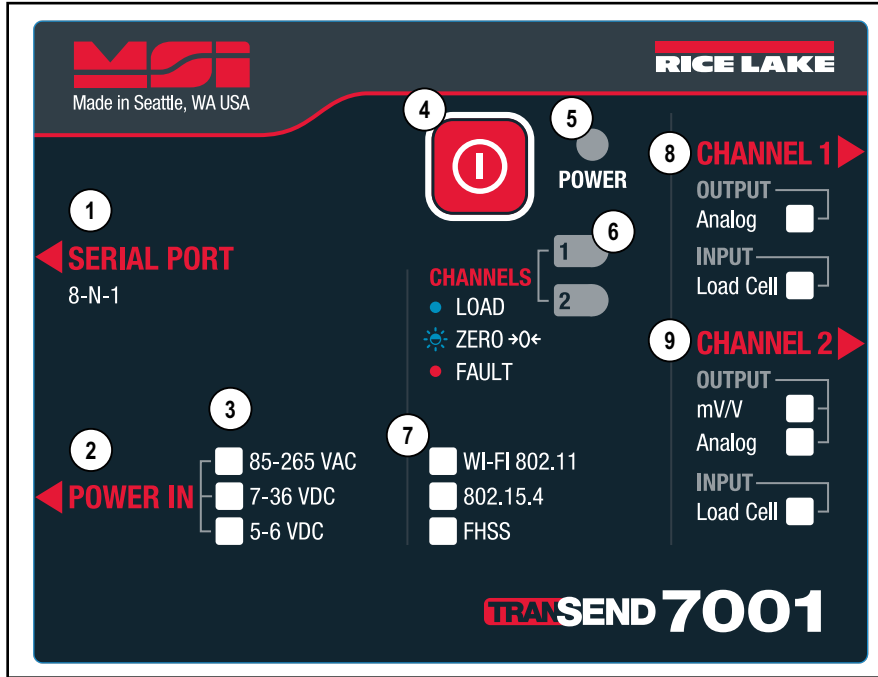

Figure 3-2. MSI-7001 Front Panel

Item No.	Description	
	Transmitter	Receiver
1	Serial Port – Located on the side of unit; Pre-set at 9600 baud and 8-N-1	Serial Port – Located on the side of unit; Pre-set at 9600 baud and 8-N-1
2	Power Input – Located on the side of the unit	Power Input – Located on the side of the unit
3	Type of Power Source – Type will be checked	Type of Power Source – Type will be checked
4	Power Button	Power Button
5	Power LED – Indicates unit is on when lit Steady Green – On with good battery (or AC) Steady Red – On with low battery Blinking Red – On with very low battery	Power LED – Indicates unit is on when lit Steady Green – On with good battery (or AC) Steady Red – On with low battery Blinking Red – On with very low battery
6	Channel LEDs – Indicates which channel is controlled by the unit Off – Sensor is disabled Steady Orange – Sensor fault (overload/underload/uncal/error/etc.) Blinking Blue – Sensor is in CoZ and working properly Steady Blue – Sensor is loaded and working properly Steady Purple – Sensor Selected (for two seconds)	Channel LEDs – Indicates which channel is controlled by the unit Off – Sensor is disabled Steady Orange – Sensor fault (overload/underload/uncal/error/etc.) Blinking Blue – Sensor is in CoZ and working properly Steady Blue – Sensor is loaded and working properly Steady Purple – Sensor Selected (for two seconds)
7	Wireless Options – Type is checked	Wireless Options – Type is checked
8	Channel 1 Output / Input – Type is checked	Output / Input – Type is checked
9	Channel 2 Output / Input – Type is checked	Output / Input – Type is checked
8	Zero Button – Press to zero the currently selected channel	Zero Button – Press to zero the currently selected channel
10	Arrow Buttons – Use to scroll through channels	Arrow Buttons – Use to scroll through channels
13	Load Cell Inputs – Located on the side of the unit	Load Cell Inputs – Located on the side of the unit

Table 3-2. MSI-7001 Front Panel Controls

## 3.5 Opening and Resealing the Enclosure

The enclosure must be opened to connect the load cell/sensor cables and other interface connections. The enclosure must be resealed to torque specifications to maintain IP rating.



**WARNING:** Before opening the unit, ensure the power is disconnected.

### 3.5.1 Opening the Enclosure

1. Place the MSI-7001 face down on an anti-static work mat.
2. Remove the screws securing the backplate to the enclosure with a phillips head screwdriver. Retain for re-installation.
3. Remove the backplate to access the interior and set it aside.

### 3.5.2 Resealing the Enclosure

1. Align enclosure gasket with the open lip of the enclosure
2. Replace lid of enclosure.
3. Replace enclosure screws with a phillips head screwdriver.
4. Torque screws to 5 in-lb.

### 3.5.3 Legal for Trade

The MSI-7001 can be sealed in legal for trade applications by placing a tamper proof sticker over an enclosure screw.

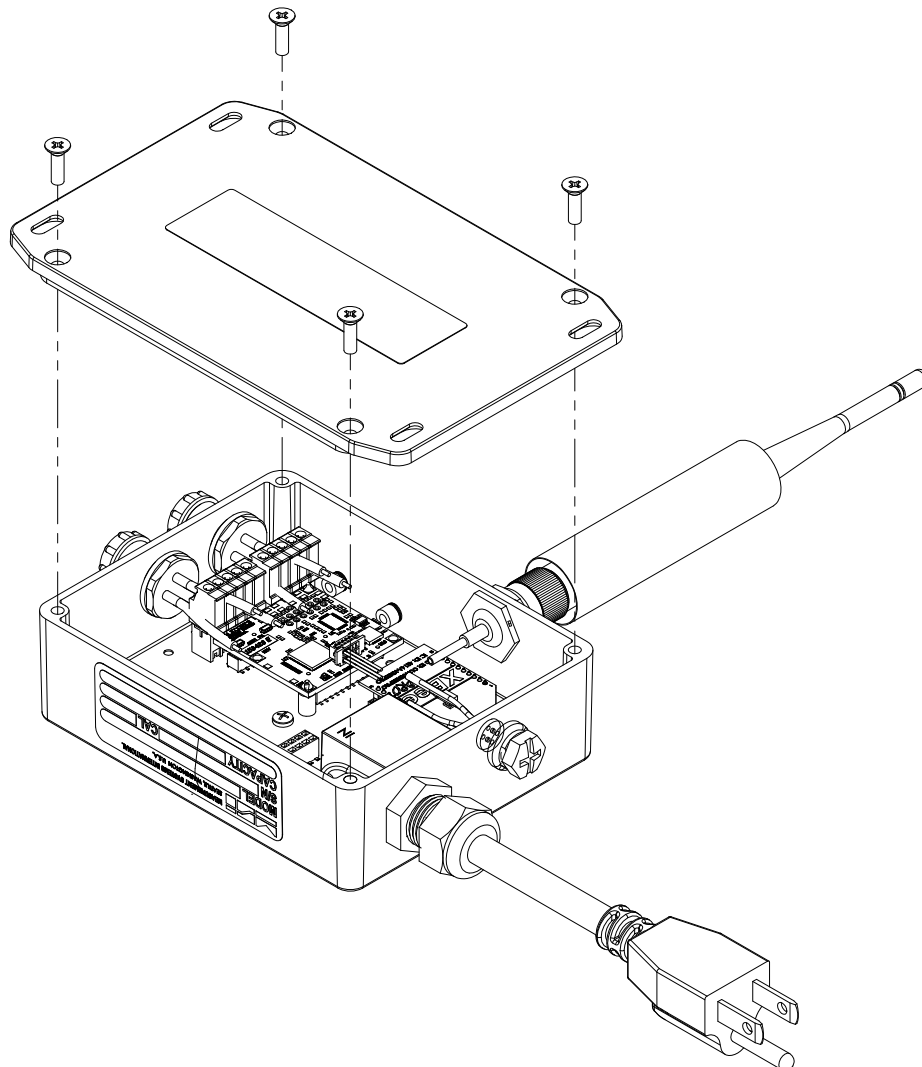



Figure 3-3. Opening and Closing the Enclosure

### 3.6 Wiring and Connections

 **WARNING:** Before opening the unit, ensure the power is disconnected.

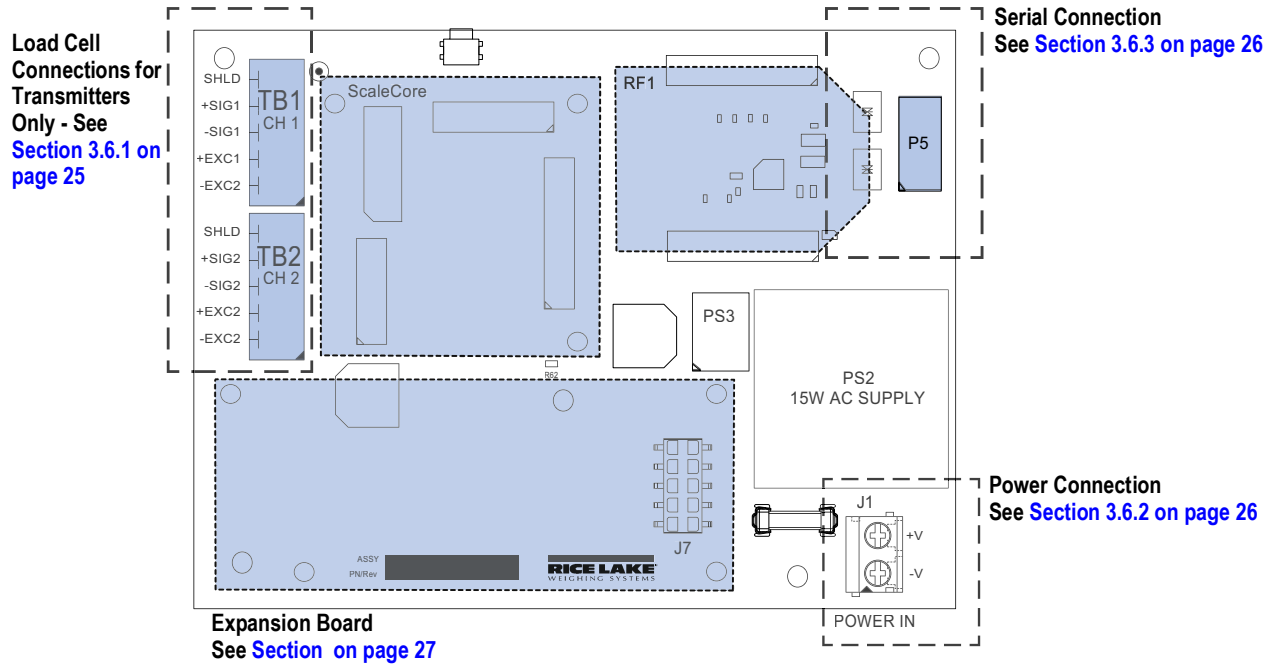

Figure 3-4. Connectors

### 3.6.1 Load Cell Cables

When using the MSI-7001 as a transmitter, connect the load cell cables to TB1 and TB2.

1. Remove backplate.
2. Loosen the cable connectors and remove the pin.
3. If connecting four load sensors, insert the two hole insert into the cable connectors.
4. Run load sensor cables through the cord grips into the indicator.
5. Loosen the screws in load sensor connector.
6. Insert stripped end of each wire into the holes of the connector.



**NOTE:** Terminal Blocks can be removed from the terminal block headers for easier load cell cable installation.

7. Re-tighten screws to secure wires.
8. Align the back plate on the enclosure and secure with screws.



**IMPORTANT:** The MSI-7001 must be calibrated once the load sensors have been connected.

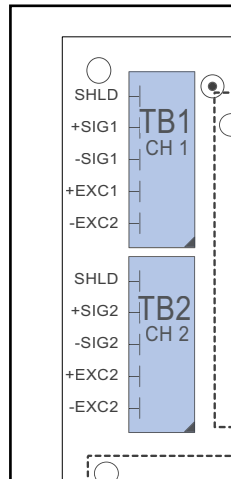

Figure 3-5. Load Cell to Terminal Block Connection



**NOTE:** In most applications it is not necessary to connect the shield to the j-box shield terminal. Sometimes noise pickup is improved by connecting the shield inside the j-box. However, it may make noise pickup worse. Test performance before cutting off the shield at the cable end.

### 3.6.2 Power Supply

**WARNING:** Before opening the unit, ensure power is disconnected.

1. Remove backplate.
2. Loosen screws in the power wire connector to pull the wires from the connector.
3. Remove the screw securing the ground wire (AC Only).
4. Loosen the cable gland and pull the power cable from the enclosure.
5. Push new cable through the cable gland and reconnect wiring as shown below.
6. Ensure all connections are tight and reinstall the back plate.

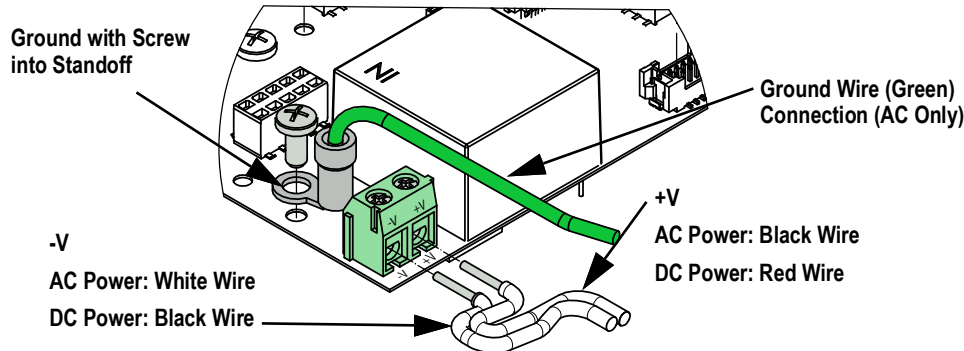

Figure 3-6. Power Supply

### 3.6.3 Serial Connections

Serial Communications defaults are set to:

- **Data Configuration:** The data output is fixed at 8-1-N.
- **Baud Rate:** Baud rate is not programmable. Serial port is set at 38.4 k baud.
- **Handshaking:** No hardware handshaking is supported. Xon/Xoff software handshaking is always on.

Remove the back cover of the MSI-7001 to access the serial connectors and connect the cable.

The MSI-7001 has one serial comm port.

- Comm port 1, P5 (Figure 3-4 on page 24) is directly wired to the external Turck® serial connector. Comm port 1 is used for software updates, connecting to a remote display and for connecting to an RS-232 device.

**IMPORTANT:** Wire shield drain to the metal shell of the connector. Disconnect shield drain wire if ground loops cause unstable readings. If necessary use an isolated RS-232 interface.

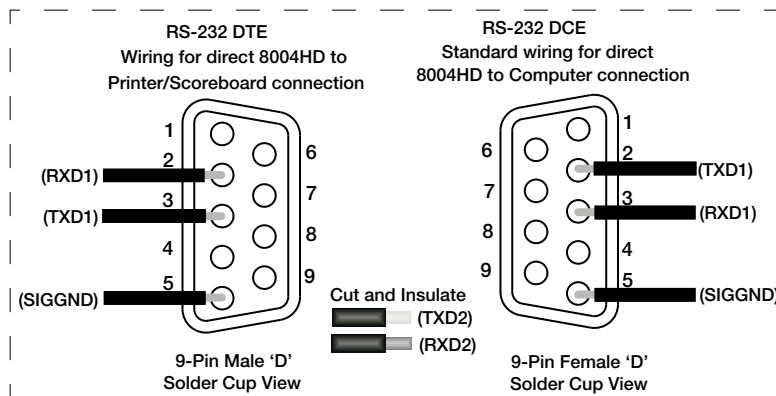

Figure 3-7. Communication Wiring

### 3.6.4 Expansion Board

The Expansion Board slot allows for options to be added to the MSI-7001 product build.

#### Analog Output Connection

The Analog Output Option provides a means to connect the MSI-7001 to analog inputs found on PLCs and other industrial equipment. The optional Analog Output board allows one or two channels of the MSI-7001 to drive the Analog Outputs. See the ScaleCore Connect or ScaleCore Webserver Technical Manuals for more information on configuring analog output.

#### PLC Wiring Diagrams

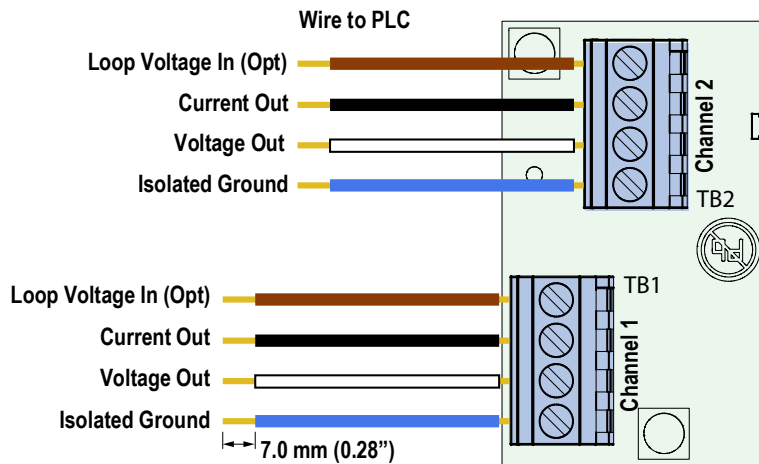

Figure 3-8. Analog Option Card

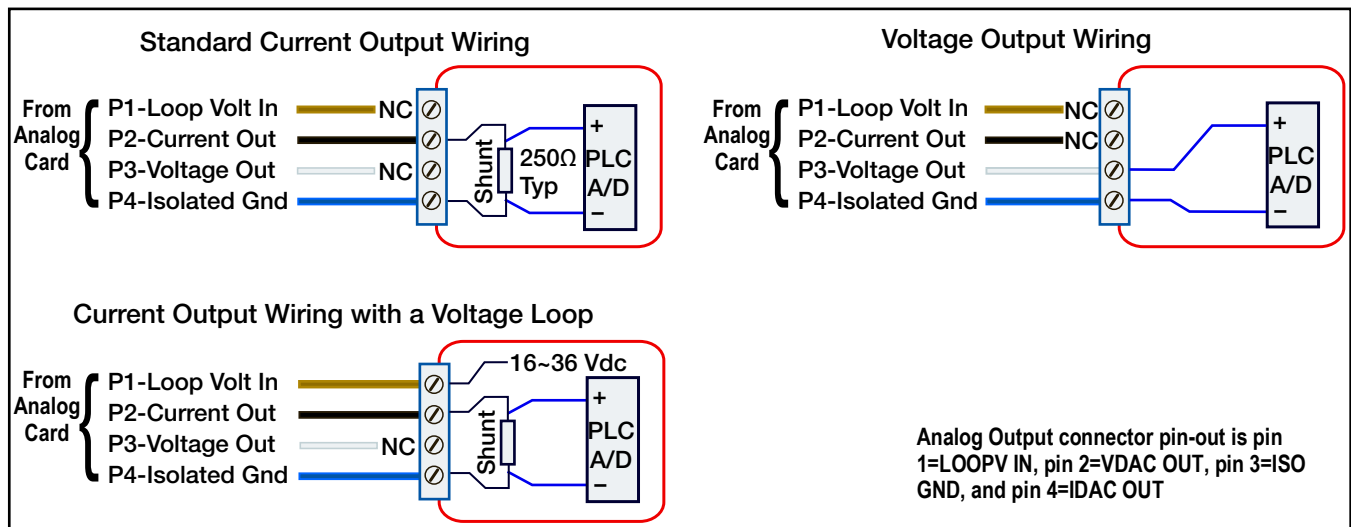

Figure 3-9. PLC Wiring

Pin #	Wire Color	Function	Comment
1	Brown	Loop Voltage In	Optional for increasing compliance. Input range: +16V to 36V max
2	Black	Current Out	Will drive 20mA into 625Ω without external boost voltage (See Table below)
3	White	Voltage Output	Specified for load resistance ≥1kΩ. Recommended load resistance: 100kΩ to minimize voltage drop due to wire resistance in connecting cable
4	Blue	Isolated Ground	Connection required for current and voltage output

Table 3-3. Analog Output Wiring

External Loop Voltage Input	20mA Output Max R <sub>wiring</sub> + R <sub>shunt</sub>	24mA Output Max R <sub>wiring</sub> + R <sub>shunt</sub>
None	625Ω	520Ω
18V	750Ω	625Ω
24V	1.05kΩ	875Ω
30V	1.35kΩ	1.125kΩ
36V	1.65kΩ	1.375kΩ

Table 3-4. Current Compliance Table

### Connecting Analog Output Cable to the Analog Output Connector

The MSI-8004HD connects to a PLC or other industrial equipment through the analog output cable. Connect the wires of the analog output cable to the analog output channels in [Figure 3-8 on page 27](#).

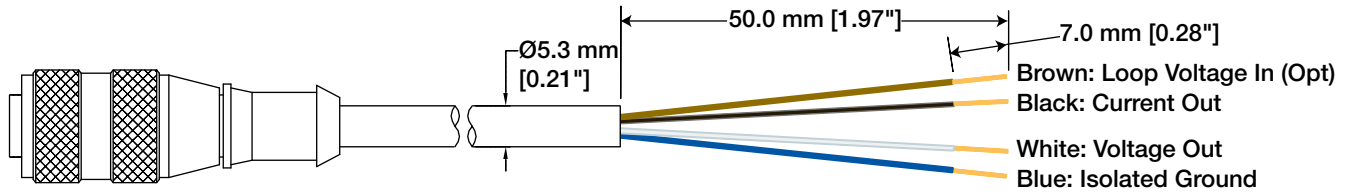

Figure 3-10. Analog Output Cable Wiring

## 4.0 Communication

This section addresses communication capabilities for the MSI TranSend 7000 Series transmitters and receivers. See the ScaleCore Connect Technical Manual and the ScaleCore Webserver Technical Manual for more information about settings and configuration.

### 4.1 Network Connections

#### 4.1.1 802.15.4 Network

The MSI TranSend 7000 Series uses 802.15.4 transceivers to communicate which operates in the 2.4 GHz systems if:

- Antennas are isolated at least 10' (3 m) from the equipment
- MSI 7000 Series TranSend based RF systems are peer to peer; In multiple scale connections, it acts as the network coordinator

The MSI TranSend 7000 Series uses three numbers to establish a piconet. Table 4-1 lists out the three elements used in setting up a piconet.



**IMPORTANT:** Unit comes preconfigured from the factory. Any changes will affect factory configuration. Consult Rice Lake Weighing Systems before changing any of these settings.

Name	Description	Recommended Number Range	
		Transmitter	Receiver
ScaleCore ID	Used to identify each device in a piconet, its range is 0–254 and cannot be duplicated within the same RF channel	20–30	0–4
RF Channel	Establishes the base network that all interconnected devices must match	12–23	
Network ID	A 64-bit number that all interconnected devices must match, do not use a small number to avoid other 802.15.4 transceivers that default to a network ID of 0	Maximum of five digits with a range of 0–65535	

**NOTE:** For all devices that interconnect, the RF channel and network ID must match. The ScaleCore ID must be unique. The Dyna-Link or crane scale that is the weight source should be set to a ScaleCore ID of 0. If other source devices are added, they can be added in sequence.

Table 4-1. Piconet Setup Ranges

#### 4.1.2 RF modem network

The MSI TranSend 7000 Series allows the use of dual RF modems. In addition to the XBee modem other options include:

- FHSS
- Wi-Fi
- Wired Ethernet

Contact Rice Lake Weighing Systems or a local dealer for more information about these options.



**NOTE:** It is possible to have multiple separate MSI ScaleCore RF networks in the same location. Each device on the same network must be on the same channel.

*For best performance, different ScaleCore networks should be on different RF channels.*



**NOTE:** Transmission strength should be set to the lowest setting possible to achieve the transmission required. Both the MSI TranSend 7000 Series Indicator and the load sensor should be set at the same transmission strength setting.

Setting	RF Power Level	Transmit Current	Note
0	10 dBm	137 mA	Lowest Transmission Power
1	12 dBm	155 mA	Default on 7300s and 8000s
2	14 dBm	170 mA	–
3	16 dBm	188 mA	–
4	18 dBm	215 mA	–

Table 4-2. Transmission Strength Settings - XBee Radio Only

## 4.2 Antenna Options



**NOTE: To meet FCC licensing rules, use only antennas supplied or recommended by Rice Lake Weighing Systems.**

Antenna placement is critical to problem-free use of the system.

- Ensure a relatively clear transmission path exists between the devices to be connected; Radio signals travel primarily by line of sight (LOS), obstructions between stations may degrade the system performance
- When using the long range antenna, mount the antenna on an elevated structure to ensure that you have a clear LOS transmission path; This will ensure the antenna will clear surrounding obstructions; Do not provide a ground plane for the antenna
- Fixed station locations often benefit from directional antennas when the location of the other components of the RF network are fixed and/or in the same direction; Never use a directional antenna on a mobile system
- If using the standard antenna, ensure the antenna is not blocked by any metal; Transmission is good through most kinds of glass so mounting a meter next to a window will work fine; If there is no clear line of sight place to mount the receiving device, consider switching to the long range antenna so the antenna can be set up remotely
- The standard and long range antennas are vertical plane devices; They should be vertical, pointing up or down, when high off the ground (like the underside of a large bridge crane); Do not mount them sideways; The long range 9 dBi antenna is particularly sensitive to off axis mounting; Use a level to ensure the antenna is exactly 90° perpendicular to the earth
- Do not mount an omni-directional antenna next to metallic or concrete surfaces; This can result in reflections and undesired RF characteristics; Use a corner reflector instead
- After installation, seal the antenna connection with an adhesive heat shrink boot; Failure to seal the antenna may result in liquid destroying the antenna and device it's connected to



**NOTE: Rice Lake Weighing Systems does not recommend extending the coaxial cable beyond three meters. At 2.4 GHz more loss will result from coax losses than are gained by raising the antenna. If the antenna must be extended, use a very low loss 50 ohm coax such as RG-214, RF-195, or other low loss varieties.**

*For very short extensions (<1m), cables made with RG-316 are suitable.*

### Standard Antenna

The standard antenna is an articulated 1/2 wave 2 dBi gain design with a standard TNC connector that mounts directly on the enclosure.

This antenna and coax connector, though resistant to water, is not water-proof. Seal the TNC base with an adhesive heat shrink boot if this antenna might be exposed to rain or other weather conditions where it could get wet.

This antenna must be vertically oriented and is suitable for most short to medium range applications.



### Long Range OMNI 9 dBi Antenna

This omni-directional high gain antenna is remotely mounted with a low loss coaxial cable and increases the range up to four times.

The antenna must be vertically mounted. The vertical Beamwidth (-3dB point) is 14 degrees.

This antenna is supplied with a 10 foot (3m) coax cable pre-attached. The 10-foot cable allows placement of the antenna above the unit for ease of clearing possible obstacles to data transmission. It is also available with an N connector for applications requiring longer coax cable lengths.

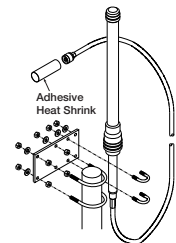

### Vehicle Mount Whip Antenna

The vehicle mount whip antenna mounts directly to the roof of mobile vehicles and is weatherproof.

This 5 dBi gain whip mounts in a 3/4" hole on the roof of the vehicle.

The mount includes 17' of low loss coax terminated in a TNC connector.



## YAGI Antenna

For maximum range, a 14 dBi gain Yagi Antenna is available by special order. Please contact Rice Lake Weighing Systems for details.



## Corner Reflector Antenna

Corner reflector antennas are often the best choice for a wall mounted antenna. Rice Lake Weighing Systems offers a 14 dBi and a 9 dBi corner reflector.



14 dBi Corner Reflector



9 dBi Corner Reflector

## Patch Antenna

The patch antenna is for applications where the standard antenna is vulnerable to physical damage or outdoor applications. The patch antenna is mildly directional which requires more care in antenna placement for long range applications. Patch antennas are available by special order only. Please contact Rice Lake Weighing Systems for details.

## 4.3 Antenna Replacement

This section contains instructions to replace the standard antenna. For other options, contact Rice Lake Weighing Systems or a local dealer.

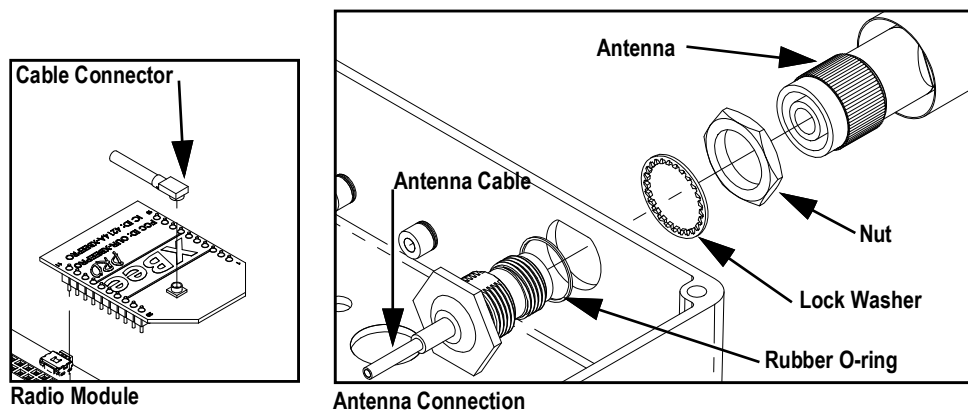

Figure 4-1. Replace Antenna

1. Remove backplate only if replacing the internal antenna cable.
2. Unscrew the antenna from the cable connector.
3. If replacing antenna cable, remove the connector and o-ring from the enclosure and disconnect from the radio module.
4. Install a new antenna or antenna cable, reverse the above steps.

## 5.0 Optional Rugged Remote

The MSI-7000 with an installed RF modem can be controlled with an optional Rugged Remote. The Rugged Remote is a transmit only device that can be used to perform basic scale functions. The range may vary up to 100 ft or more depending on room conditions and line of sight.

The RF modem in the MSI-7000 must be configured to accept communication from the Rugged Remote, contact Rice Lake Weighing Systems for pairing requirements.



**NOTE:** A Rugged Remote is paired to an individual device and cannot be reprogrammed in the field.



Figure 5-1. Rugged Remote

### 5.1 Operation

The Rugged Remote is paired to a single ScaleCore RF device and replicates the front panel buttons. Slight variations between each device's buttons will result in different operation in the Rugged Remote. See Table 5-1 for corresponding buttons for the Rugged Remote and the connected device.



**NOTE:** The Rugged Remote can only be paired to a single ScaleCore device. Reprogramming to configure communication to a different ScaleCore device can only be performed at the factory or with the purchase of additional RF modems.

Rugged Remote	Description
	Power
	Zero
	Tare
	Function

Table 5-1. Corresponding Buttons

### 5.1.1 Power

The Rugged Remote can be enabled to turn on and off the ScaleCore device it is paired remotely. The hold function must be enabled.



**NOTE:** *The Hold feature causes the device's modem to stay on and continuously draw from the battery, even when the device is turned off, resulting in decreased battery life.*

### 5.1.2 Zero



Press  to remove small deviations in zero when the scale is unloaded.

This key is not programmable.

### 5.1.3 Tare

Press  to tare the scale.

### 5.1.4 Programmable Function Keys

 and  are programmable in the scale. Function is defaulted to Test. See scale manual to configure the function key for Rugged Remote operation.

## 6.0 Replacement Parts

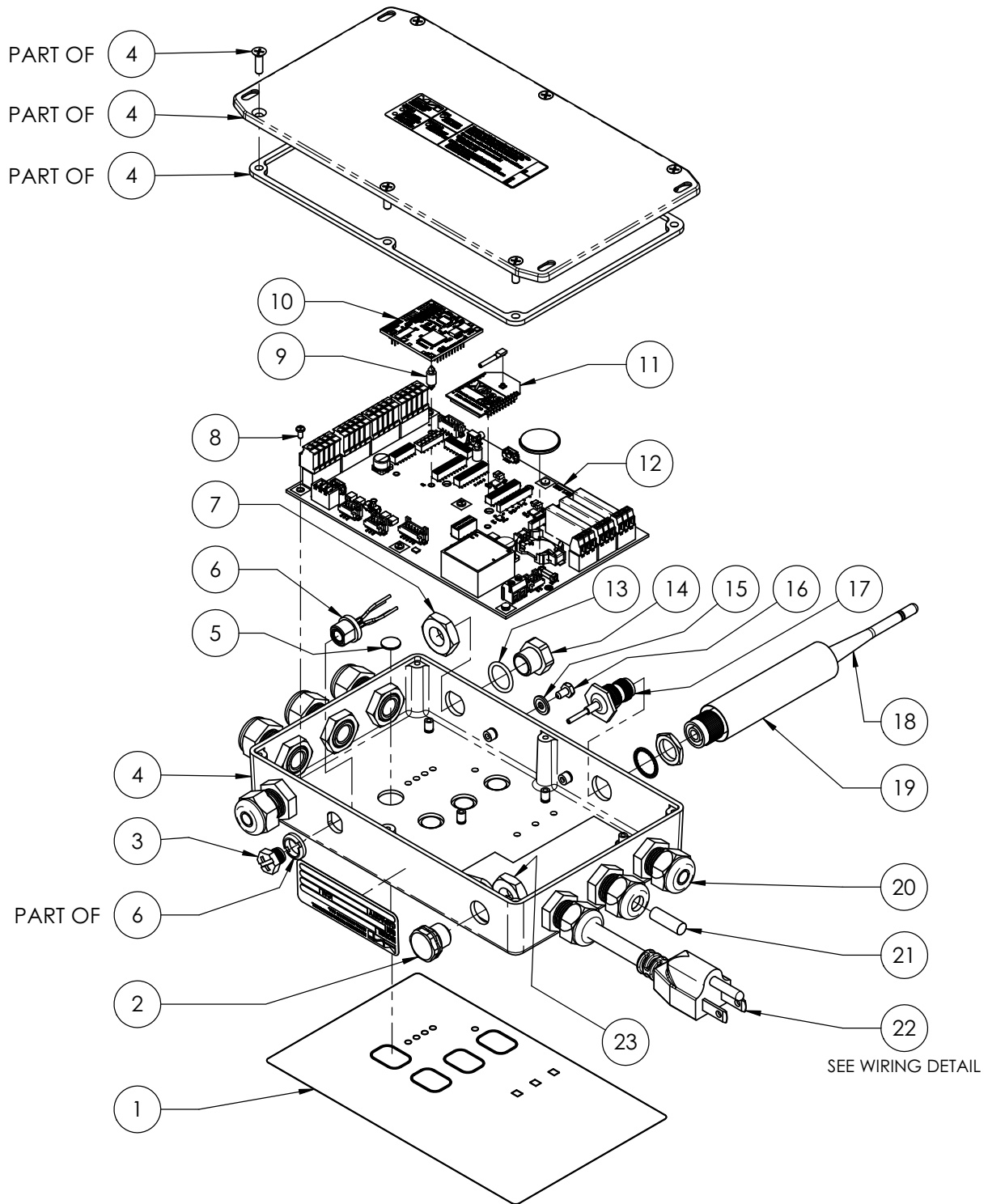

Figure 6-1. MSI-7000 Replacement Parts

Item No.	Part No.	Description
1	226496	Overlay, 7000 Gen2
2	88433	Vent, breather sealed
3	144908	Conn closure cap IP68
4	226487	Enclosure machined
5	161540	Shim disk 3/8 x .035 w/ adhesive
6	159842	Cable Assembly, serial
7	159583	Nut, M12 nylon
8	142233	Screw, machine pan head, 4-40 x 3/16, Phillips, stainless steel
9	144929	Spacer, miniature dual locking, 6 mm long
10	153431	PCA ScaleCore3 4-channel
11	144733	Radio module Xbee-pro
12	221279	PCA 7000 AC w/ coil relays
13	153793	O-ring 1/2 in ID
14	159584	Plug, M12 nylon
15	143272	Washer seal #6 steel
16	142574	Screw hh dr hd ss slk 6-32 1/4
17	159205	Cable assembly RF coax TNC
18	143283	Antenna 2.4 GHz, articulated w/ TNC connector
19	142925	Heat Shrink polyolefin
20	141593	Conn feed through liquid tight
21	141991	Pin round acetal, .25 dia
22	159189	AC poser cord
23	88734	Nut, breather vent

Table 6-1. MSI-7000 Parts List

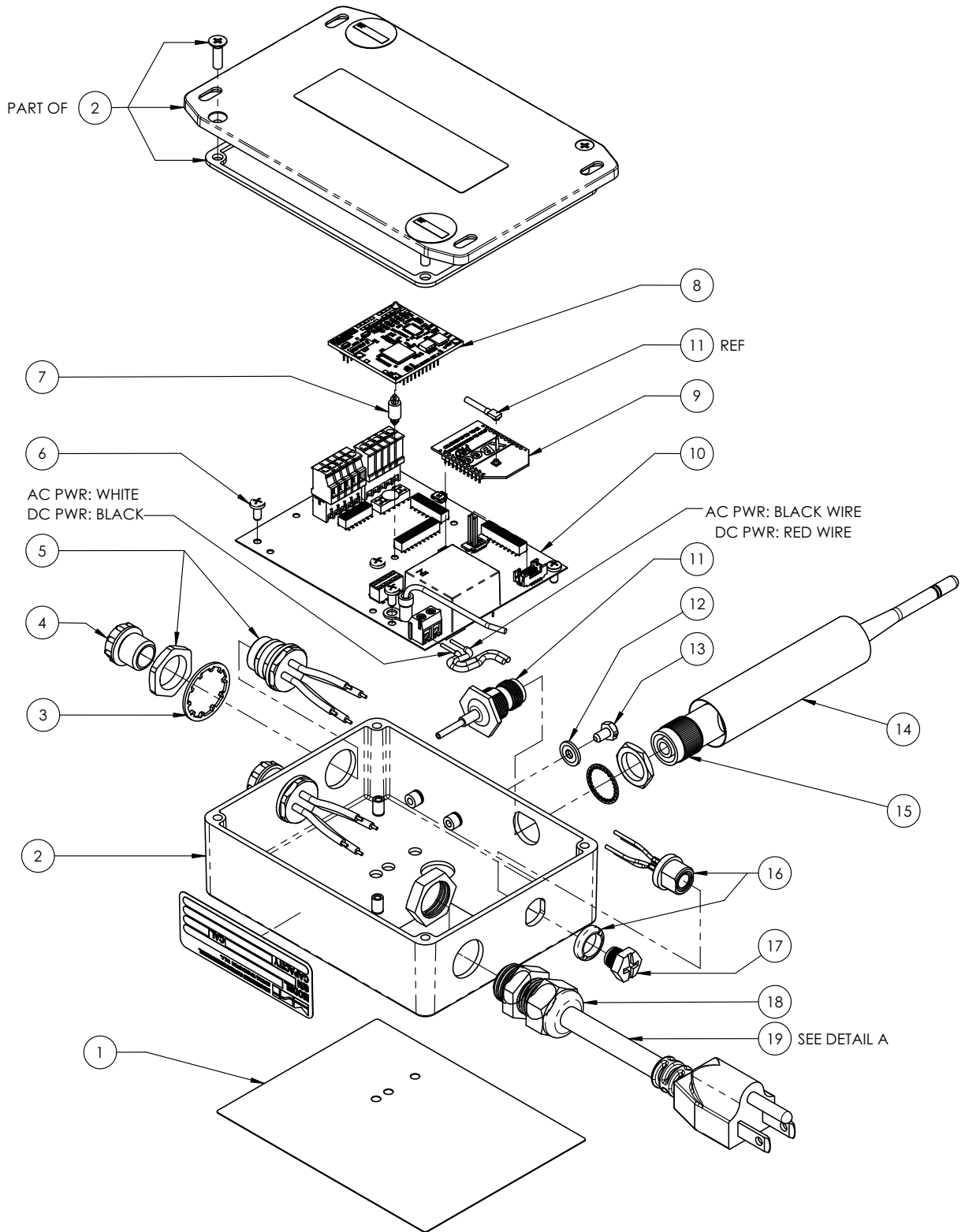

Figure 6-2. MSI-7001 Replacement Parts

Item No.	Part No.	Description
1	230320	Overlay
2	229662	Enclosure machined
3	171384	Lock washer internal tooth 14mm
4	143352	Conn closure cap IP68 male
5	231015	Cable assembly sensor 7001 gen 2
6	128088	Screw machine 4-40 x 1/4 Phillips, stainless steel
7	144929	Space, miniature dual locking, 6mm long
8	153431	PCA ScaleCore3 4-channel
9	144773	Radio module Xbee-pro
10	231219	PCA 7001 Gen2 85-265 VAC
11	152051	Cable assembly rf coax tnc
12	143272	Washer seal #6 steel
13	142574	Screw hh ddr hd ss blk 6032 1/4
14	142925	Heat shrink polyolefin
15	143283	Antenna 2.4 GHz, articulated w/ tnc connector
16	159842	Cable assembly serial
17	144908	Con closure cap IP68 picofast male
18	141593	Conn feed through liquid
19	159189	AC power cord

Table 6-2. MSI-7001 Parts List

## 7.0 Specifications

---

### Power

MSI-7000: 85-265 VAC

MSI-7001: 85-265 VAC

Other power options available upon request

### Excitation Voltage

Transmitter: +4.8 VDC, 16 x 350 ohm or 32 x 700 ohm load cells

### Standard Antenna

1/2 wave 2dBi, articulated

### Frequency

Direct sequence spread spectrum at 2.4 GHz, 802.15.4

### Effective Range

Typically 100 to 300 ft, line of sight; for longer range consult factory

### Communication Ports

Full duplex RS-232

### Circuit Protection

RFI, EMI, ESD protection

### Operating Temperature

-40 °F to 185 °F (-40 °C to 85 °C)

### Rating/Material

MSI-7000: NEMA Type 4 (IP65), aluminum black powder coated (excludes wall cube model)

MSI-7001:

### Additional RF Options

Wi-Fi

802.15.4

FHSS

### Warranty

One-year limited

### Certifications



#### NTEP

MSI-7000 and MSI-7001 only

Certification Number: 15-109

$n_{max}$ : 10,000

Accuracy: III / III L





© Rice Lake Weighing Systems Content subject to change without notice.

230 W. Coleman St. • Rice Lake, WI 54868 • USA USA: 800-472-6703 • International: +1-715-234-9171