

Picture is a representation of actual product.

Interchangeable Products

AVERY WEIGH-TRONIX®
FLS

Specifications

- Full Scale Output:**
1.0 (± 10%) mV/V
- Output Resistance:**
350 (± 3) ohm
- Input Resistance:**
385 (± 10) ohm
- Material/Finish:**
Stainless steel
- Temperature:**
Operating range
0 °F to 150 °F (-18 °C to 65 °C)
- Seal Type:**
Environmentally sealed, IP67
- Safe Overload:**
150% full scale
- Rated Excitation:**
5 to 15 VDC
- Hysteresis:**
0.02% full scale
- Non-Linearity:**
0.02% full scale
- Insulation Resistance:**
5,000 megohm
- Cable Length:**
10 ft
- Cable Color Code:**
Green +Excitation
Black -Excitation
Red +Signal
White -Signal
- Warranty:**
Two-year limited

Order Information

Load Rating	Part #	Est. Weight	Price
50 lb	125612	3 lb	Consult

Dimensions

Rated Capacity	A	B	C	D	E	F	H	J	T
50 lb/in									
50	5.50	2.90	0.74	6.50	2.00	0.50	0.50	0.45	5/16-18 UNC x 0.50

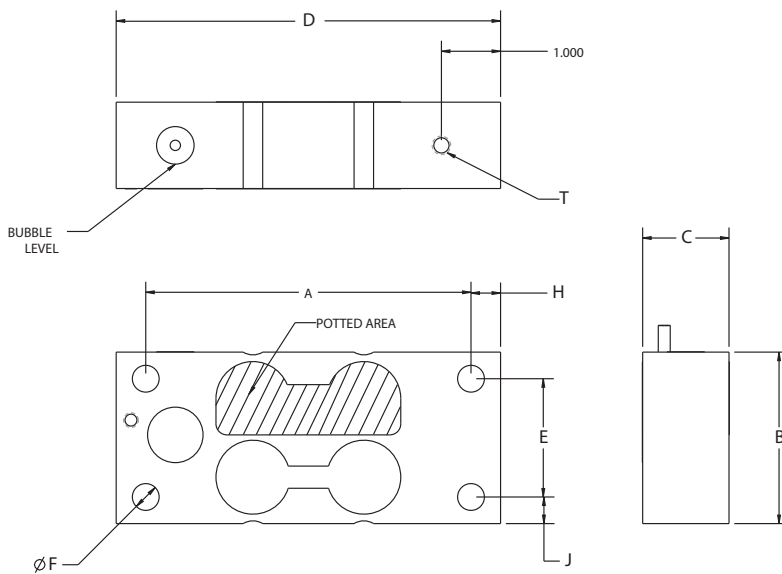

**RICE LAKE
LOAD CELLS**