

In-Motion Weighing

TABLE OF CONTENTS

ELS Series	584
<i>Elevated Load Cell Stands</i>	
MotoWeigh® IMW	586
<i>In-Motion Conveyor Scale and Checkweigher</i>	
MotoWeigh® Metal Detector	591
MotoWeigh® Cascade Checkweigher	593
<i>Gravity Drop Checkweigher</i>	
Motoweigh® Integrator	593
A&D Inspection	594
<i>In-Motion Checkweigher and Metal Detector</i>	
RT-M	596
<i>Roller Top Scale</i>	

The following product names, logos, brands and other trademarks featured or referred to within this publication are the property of their respective trademark holders.

ELS Series

Elevated Load Cell Stands



Mild Steel ELS

Standard Features

- Adjustable height and width in 1-inch increments
- Mild or stainless steel frame
- Individual load cell overload protection
- Jack bolts in leveling feet for easy conveyor height alignment
- Kit includes: two stands, load cells, junction box, two adjustable stabilizing braces, leveling shims and hardware

Options

- Indicator stand – mild or stainless steel
- Additional single ELS weigh stand
- Additional stabilizing brace kit
- *Rollers and conveyors are not included and are from other manufacturers

Specifications

Load Cell:

Four RL32018 or RL32018S single-ended beam:
250 lb, 500 lb and 1,000 lb capacity

Cable Length:

25 ft

Warranty:

Two-year limited

Approvals:

Load cells are FM approved

Part Number/Price

Part #	Length	Width	Height	Price
Mild Steel - Overall Product Dimensions				
ELS-250 Kit (Load Rating 500 lbs)				
212655	30 to 60 in	22 to 28 in	22 to 28 in	\$3,900.00
212656	30 to 60 in	22 to 28 in	29 to 36 in	\$3,900.00
212659	30 to 60 in	29 to 40 in	22 to 28 in	\$3,950.00
212660	30 to 60 in	29 to 40 in	29 to 36 in	\$3,950.00
212957	30 to 60 in	41 to 58 in	22 to 28 in	\$3,950.00
212958	30 to 60 in	41 to 58 in	29 to 36 in	\$3,950.00
ELS-500 Kit (Load Rating 1,000 lbs)				
212661	30 to 60 in	22 to 28 in	22 to 28 in	\$3,950.00
212662	30 to 60 in	22 to 28 in	29 to 36 in	\$3,950.00
212663	30 to 60 in	29 to 40 in	22 to 28 in	\$4,000.00
212665	30 to 60 in	29 to 40 in	29 to 36 in	\$4,000.00
212953	30 to 60 in	41 to 58 in	22 to 28 in	\$4,000.00
212954	30 to 60 in	41 to 58 in	29 to 36 in	\$4,000.00
ELS-1000 Kit (Load Rating 2,000 lbs)				
212666	30 to 60 in	22 to 28 in	22 to 28 in	\$4,100.00
212667	30 to 60 in	22 to 28 in	29 to 36 in	\$4,100.00
212669	30 to 60 in	29 to 40 in	22 to 28 in	\$4,150.00
212670	30 to 60 in	29 to 40 in	29 to 36 in	\$4,150.00
212949	30 to 60 in	41 to 58 in	22 to 28 in	\$4,200.00
212950	30 to 60 in	41 to 58 in	29 to 36 in	\$4,200.00
Stainless Steel				
ELS-250 Kit (Load Rating 500 lbs)				
213276	30 to 60 in	22 to 28 in	22 to 28 in	\$6,150.00
213278	30 to 60 in	22 to 28 in	29 to 36 in	\$6,250.00
213280	30 to 60 in	29 to 40 in	22 to 28 in	\$6,300.00
213282	30 to 60 in	29 to 40 in	29 to 36 in	\$6,350.00
213283	30 to 60 in	41 to 58 in	22 to 28 in	\$6,450.00
213284	30 to 60 in	41 to 58 in	29 to 36 in	\$6,550.00
ELS-500 Kit (Load Rating 1,000 lbs)				
213292	30 to 60 in	22 to 28 in	22 to 28 in	\$6,200.00
213293	30 to 60 in	22 to 28 in	29 to 36 in	\$6,300.00
213294	30 to 60 in	29 to 40 in	22 to 28 in	\$6,300.00
213295	30 to 60 in	29 to 40 in	29 to 36 in	\$6,400.00
213296	30 to 60 in	41 to 58 in	22 to 28 in	\$6,450.00
213297	30 to 60 in	41 to 58 in	29 to 36 in	\$6,550.00
ELS-1000 Kit (Load Rating 2,000 lbs)				
213304	30 to 60 in	22 to 28 in	22 to 28 in	\$6,200.00
213305	30 to 60 in	22 to 28 in	29 to 36 in	\$6,300.00
213306	30 to 60 in	29 to 40 in	22 to 28 in	\$6,300.00
213307	30 to 60 in	29 to 40 in	29 to 36 in	\$6,400.00
213308	30 to 60 in	41 to 58 in	22 to 28 in	\$6,450.00
213309	30 to 60 in	41 to 58 in	29 to 36 in	\$6,550.00

NOTE: Height is the floor to top mounting plate measurement
Width and Height adjustable in 1 inch increments

IN-MOTION
WEIGHING

Options/Accessories

Part #	Description	Price
19352	Indicator floor stand mild steel, 36.3 in high	\$250.00
28740	Indicator floor stand SST, 36.3 in high	\$340.00
Consult	Single ELS weigh stand	Consult
213229	Additional stabilizing brace kit mild steel	\$300.00
213316	Additional stabilizing brace kit stainless steel	\$550.00

Dimensions

	Kit Variation	Minimum Dimension	Maximum Dimension
A	Small	22 in (55.88 cm)	28 in (71.12 cm)
	Large	29 in (73.66 cm)	36 in (91.44 cm)
B	All	30 in (76.20 cm)	60 in (152.40 cm)
C	Small	17 in (43.18 cm)	24 in (60.96 cm)
	Medium	25 in (63.50 cm)	36 in (91.44 cm)
D	Small	22 in (55.88 cm)	28 in (71.12 cm)
	Large	41 in (104.14 cm)	58 in (147.32 cm)

Dimensions A, C and D are adjustable in one inch increments

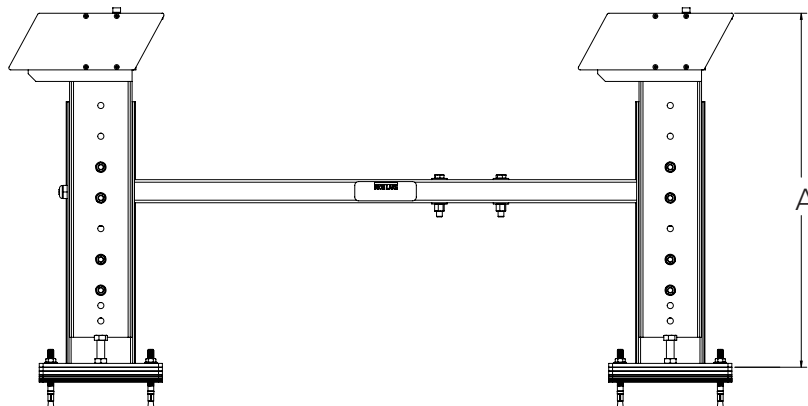
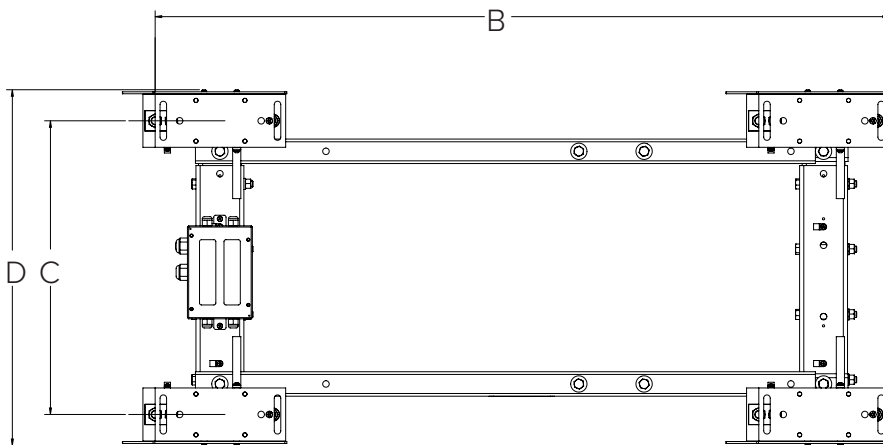

IN-MOTION
WEIGHING

MotoWeigh® IMW

In-Motion Conveyor Scale and Checkweigher



Approvals



Optional



Optional

Standard Features

Software

- Password protected user logins
- Real-time statistical information
- Product report
- Statistical report
- Parameter report
- User report
- Store up to 1,000 different products
- Five-zone classification

Control Panel

- 1280 controller
- Power disconnect with lock-out/tag-out
- E-stop
- VFD (variable frequency drive)
- Motor overloads

Hardware

- Square tube construction (SST or aluminum)
- 32 in height from top of belt with ± 2.5 in of adjustment
- Modular belting

Options

- Divert methods:
 - Pneumatic pusher
 - Air blast
 - Drop conveyor
 - Paddle
 - Secondary diverter in series or parallel
- One-, three- or five -zone communication tower
- Audible alarm (non-washdown only)
- Draft shields
- Drop chutes
- Pull cord E-stops
- Portability package (non-NTEP Certified only)
- Conveyor guide rails (round or flat)
- Custom programming available
- Food-grade SST angle construction, NEMA Type 4X IP66 washdown systems
- Meets HACCP requirements
- UL 508
- NTEP Certified Legal for Trade (up to 2,000 divisions and 60 ppm)
- Pacing conveyor

Specifications

Construction:

- Stainless steel food-grade
- Stainless steel non-food-grade
- Aluminum non-food-grade

Configurations:

- Checkweigher
- Conveyor scale

Speed:

- Up to 240 ft per minute

Container Types:

- Boxes, bags, pouches, trays, tubs, cups, blister packs, display packs, clam shells

Belts:

- Intralox® Habasit®

Power Configuration:

- 110 VAC single phase, 60 Hz
- 230/460 VAC 3 phase, 60 Hz

Warranty:

- Two-year limited (excludes powertrain and wear parts)

Checkweigher Packages:

- NTEP Certified and non-NTEP Certified packages available in stainless steel and aluminum for food and non-food-grade applications

Checkweigher Packages Include:

- Common framework for mounting conveyor scale on same frame as infeed conveyor and indicator
- Basic control enclosure to interconnect wiring from photo eyes and divert solenoid and conveyor on/off/E-stop

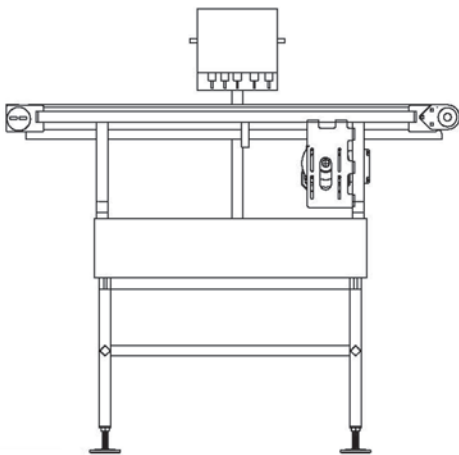
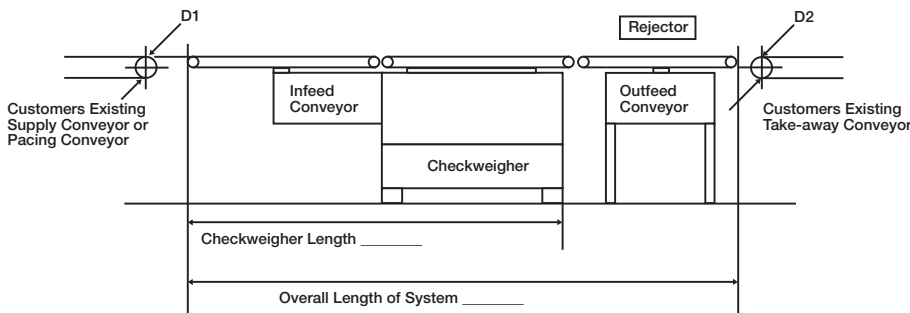

Side View
Conveyor Scale

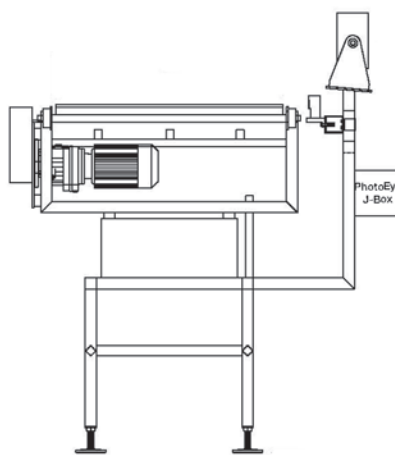

End View
Conveyor Scale

Due to the variety of configurations, please consult a sales engineer to discuss application requirements and for complete specifications and price quotations.

Field installation available at pre-determined rates.

Questionnaire available at www.ricelake.com/motoweigh

Example Conveyor System Sizes and Configurations

Configuration	Scale Width	Scale Length	Capacity	PPM	Material
Scale Conveyor Only	6	12	10, 20	Min Length: 3 in Max Length (40ppm): 7 in Max Length (75ppm): 3 in	AL, Ind Welded
					SST, Ind Welded
					SST, Food Grade Welded
	6	18	10, 20	Min Length: 3 in Max Length (40ppm): 11.5 in Max Length (80ppm): 5 in	AL, Ind Welded
					SST, Ind Welded
					SST, Food Grade Welded
	6	24	10, 20	Min Length: 3 in Max Length (40ppm): 15.5 in Max Length (80ppm): 7.5 in	AL, Ind Welded
					SST, Ind Welded
					SST, Food Grade Welded
Checkweigher with Linear Thrust Reject Device (Includes: Infeed, scale, and outfeed conveyors. All conveyors same length.)	6	12	10, 20	Min Length: 3 in Max Length (40ppm): 7 in Max Length (75ppm): 3 in	AL, Ind Welded
					SST, Ind Welded
					SST, Food Grade Welded
	6	18	10, 20	Min Length: 3 in Max Length (40ppm): 11.5 in Max Length (80ppm): 5 in	AL, Ind Welded
					SST, Ind Welded
					SST, Food Grade Welded
	6	24	10, 20	Min Length: 3 in Max Length (40ppm): 15.5 in Max Length (80ppm): 7.5 in	AL, Ind Welded
					SST, Ind Welded
					SST, Food Grade Welded
Scale Conveyor Only	12	18	10, 20, 40	Min Length: 3 in (6 in@40 lb) Max Length (40ppm): 11.5 in Max Length (80ppm): 5 in	AL, Ind Welded
					SST, Ind Welded
					SST, Food Grade Welded
	12	24	10, 20, 40	Min Length: 3 in (6 in@40 lb) Max Length (40ppm): 15.5 in Max Length (80ppm): 7.5 in	AL, Ind Welded
					SST, Ind Welded
					SST, Food Grade Welded
	12	30	10, 20, 40	Min Length: 3 in (6 in@40 lb) Max Length (40ppm): 20 in Max Length (80ppm): 10 in	AL, Ind Welded
					SST, Ind Welded
					SST, Food Grade Welded
	12	36	10, 20, 40	Min Length: 3 in (6 in@40 lb) Max Length (35ppm): 25.5 in Max Length (70ppm): 15.5 in	AL, Ind Welded
					SST, Ind Welded
					SST, Food Grade Welded
Checkweigher with Linear Thrust Reject Device (Includes: Infeed, scale, and outfeed conveyors. All conveyors same length.)	12	18	10, 20, 40	Min Length: 3 in (6 in@40 lb) Max Length (40ppm): 11.5 in Max Length (80ppm): 5 in	AL, Ind Welded
					SST, Ind Welded
					SST, Food Grade Welded
	12	24	10, 20, 40	Min Length: 3 in (6 in@40 lb) Max Length (40ppm): 15.5 in Max Length (80ppm): 7.5 in	AL, Ind Welded
					SST, Ind Welded
					SST, Food Grade Welded
	12	30	10, 20, 40	Min Length: 3 in (6 in@40 lb) Max Length (40ppm): 20 in Max Length (80ppm): 10 in	AL, Ind Welded
					SST, Ind Welded
					SST, Food Grade Welded
	12	36	10, 20, 40	Min Length: 3 in (6 in@40 lb) Max Length (35ppm): 25.5 in Max Length (70ppm): 15.5 in	AL, Ind Welded
					SST, Ind Welded
					SST, Food Grade Welded

IN-MOTION WEIGHING

MotoWeigh® IMW

In-Motion Conveyor Scale and Checkweigher

Example Conveyor System Sizes and Configurations

Configuration	Scale Width	Scale Length	Capacity	PPM	Material
Scale Conveyor Only	18	24	20, 40, 100	Min Length: 6 in (3 in@20 lb) Max Length (40ppm): 15.5 in Max Length (80ppm): 7.5 in	AL, Ind Welded
					SST, Ind Welded
					SST, Food Grade Welded
	18	30	20, 40, 100	Min Length: 6 in (3 in@20 lb) Max Length (40ppm): 20 in Max Length (80ppm): 10 in	AL, Ind Welded
					SST, Ind Welded
					SST, Food Grade Welded
	18	36	20, 40, 100	Min Length: 6 in (3 in@20 lb) Max Length (35ppm): 25.5 in Max Length (70ppm): 15.5 in	AL, Ind Welded
					SST, Ind Welded
					SST, Food Grade Welded
	18	42	20, 40, 100	Min Length: 6 in (3 in@20 lb) Max Length (30ppm): 32 in Max Length (60ppm): 22 in	AL, Ind Welded
					SST, Ind Welded
					SST, Food Grade Welded
	18	48	20, 40, 100	Min Length: 6 in (3 in@20 lb) Max Length (30ppm): 36.5 in Max of 54ppm	AL, Ind Welded
					SST, Ind Welded
					SST, Food Grade Welded
Checkweigher with Linear Thrust Reject Device (Includes: Infeed, scale, and outfeed conveyors. All conveyors same length.)	18	24	20, 40, 100	Min Length: 6 in (3 in@20 lb) Max Length (40ppm): 15.5 in Max Length (80ppm): 7.5 in	AL, Ind Welded
					SST, Ind Welded
					SST, Food Grade Welded
	18	30	20, 40, 100	Min Length: 6 in (3 in@20 lb) Max Length (40ppm): 20 in Max Length (80ppm): 10 in	AL, Ind Welded
					SST, Ind Welded
					SST, Food Grade Welded
	18	36	20, 40, 100	Min Length: 6 in (3 in@20 lb) Max Length (35ppm): 25.5 in Max Length (70ppm): 15.5 in	AL, Ind Welded
					SST, Ind Welded
					SST, Food Grade Welded
	18	42	20, 40, 100	Min Length: 6 in (3 in@20 lb) Max Length (30ppm): 32 in Max Length (60ppm): 22 in	AL, Ind Welded
					SST, Ind Welded
					SST, Food Grade Welded
	18	48	20, 40, 100	Min Length: 6 in (3 in@20 lb) Max Length (30ppm): 36.5 in Max of 54ppm	AL, Ind Welded
					SST, Ind Welded
					SST, Food Grade Welded
Scale Conveyor Only	24	30	40, 100	Min Length: 6 in Max Length (40ppm): 20 in Max Length (80ppm): 10 in	AL, Ind Welded
					SST, Ind Welded
					SST, Food Grade Welded
	24	36	40, 100	Min Length: 6 in Max Length (35ppm): 25.5 in Max Length (70ppm): 15.5 in	AL, Ind Welded
					SST, Ind Welded
					SST, Food Grade Welded
	24	42	40, 100	Min Length: 6 in Max Length (30ppm): 32 in Max Length (60ppm): 22 in	AL, Ind Welded
					SST, Ind Welded
					SST, Food Grade Welded
	24	48	40, 100	Min Length: 6 in Max Length (30ppm): 36.5 in Max of 54ppm	AL, Ind Welded
					SST, Ind Welded
					SST, Food Grade Welded
	24	54	40, 100	Min Length: 6 in Max Length (30ppm): 41.5 in Max of 48ppm	AL, Ind Welded
					SST, Ind Welded
					SST, Food Grade Welded
24	60	40, 100	Min Length: 6 in Max Length (30ppm): 46 in Max of 44ppm	AL, Ind Welded	
				SST, Ind Welded	
				SST, Food Grade Welded	

IN-MOTION WEIGHING

Example Conveyor System Sizes and Configurations						
Configuration	Scale Width	Scale Length	Capacity	PPM	Material	
Checkweigher with Linear Thrust Reject Device (Includes: Infeed, scale, and outfeed conveyors. All conveyors same length.)	24	30	40, 100	Min Length: 6 in Max Length (40ppm): 20 in Max Length (80ppm): 10 in	AL, Ind Welded	
					SST, Ind Welded	
					SST, Food Grade Welded	
	24	36	40, 100	Min Length: 6 in Max Length (35ppm): 25.5 in Max Length (70ppm): 15.5 in	AL, Ind Welded	
					SST, Ind Welded	
					SST, Food Grade Welded	
	24	42	40, 100	Min Length: 6 in Max Length (30ppm): 32 in Max Length (60ppm): 22 in	AL, Ind Welded	
					SST, Ind Welded	
					SST, Food Grade Welded	
	24	48	40, 100	Min Length: 6 in Max Length (30ppm): 36.5 in Max of 54ppm	AL, Ind Welded	
					SST, Ind Welded	
					SST, Food Grade Welded	
	24	54	40, 100	Min Length: 6 in Max Length (30ppm): 41.5 in Max of 48ppm	AL, Ind Welded	
					SST, Ind Welded	
					SST, Food Grade Welded	
	24	60	40, 100	Min Length: 6 in Max Length (30ppm): 46 in Max of 44ppm	AL, Ind Welded	
					SST, Ind Welded	
					SST, Food Grade Welded	
Scale Conveyor Only	30	36	100, 200	Min Length: 6 in Max Length (35ppm): 25.5 in Max Length (70ppm): 15.5 in	AL, Ind Welded	
					SST, Ind Welded	
					SST, Food Grade Welded	
	30	42	100, 200	Min Length: 6 in Max Length (30ppm): 32 in Max Length (60ppm): 22 in	AL, Ind Welded	
					SST, Ind Welded	
					SST, Food Grade Welded	
	30	48	100, 200	Min Length: 6 in Max Length (30ppm): 36.5 in Max of 54ppm	AL, Ind Welded	
					SST, Ind Welded	
					SST, Food Grade Welded	
	30	54	100, 200	Min Length: 6 in Max Length (30ppm): 41.5 in Max of 48ppm	AL, Ind Welded	
					SST, Ind Welded	
					SST, Food Grade Welded	
	30	60	100, 200	Min Length: 6 in Max Length (30ppm): 46 in Max of 44ppm	AL, Ind Welded	
					SST, Ind Welded	
					SST, Food Grade Welded	
	Checkweigher with Linear Thrust Reject Device (Includes: Infeed, scale, and outfeed conveyors. All conveyors same length.)	30	36	100, 200	Min Length: 6 in Max Length (35ppm): 25.5 in Max Length (70ppm): 15.5 in	AL, Ind Welded
						SST, Ind Welded
						SST, Food Grade Welded
30		42	100, 200	Min Length: 6 in Max Length (30ppm): 32 in Max Length (60ppm): 22 in	AL, Ind Welded	
					SST, Ind Welded	
					SST, Food Grade Welded	
30		48	100, 200	Min Length: 6 in Max Length (30ppm): 36.5 in Max of 54ppm	AL, Ind Welded	
					SST, Ind Welded	
					SST, Food Grade Welded	
30		54	100, 200	Min Length: 6 in Max Length (30ppm): 41.5 in Max of 48ppm	AL, Ind Welded	
					SST, Ind Welded	
					SST, Food Grade Welded	
30		60	100, 200	Min Length: 6 in Max Length (30ppm): 46 in Max of 44ppm	AL, Ind Welded	
					SST, Ind Welded	
					SST, Food Grade Welded	

IN-MOTION WEIGHING

MotoWeigh® IMW

In-Motion Conveyor Scale and Checkweigher

Example Conveyor System Sizes and Configurations

Configuration	Scale Width	Scale Length	Capacity	PPM	Material
Scale Conveyor Only	36	42	100, 200	Min Length: 6 in Max Length (30ppm): 32 in Max Length (60ppm): 22 in	AL, Ind Welded
					SST, Ind Welded
					SST, Food Grade Welded
	36	48	100, 200	Min Length: 6 in Max Length (30ppm): 36.5 in Max of 54ppm	AL, Ind Welded
					SST, Ind Welded
					SST, Food Grade Welded
	36	54	100, 200	Min Length: 6 in Max Length (30ppm): 41.5 in Max of 48ppm	AL, Ind Welded
					SST, Ind Welded
	36	60	100, 200	Min Length: 6 in Max Length (30ppm): 46 in Max of 44ppm	AL, Ind Welded
					SST, Ind Welded
					SST, Food Grade Welded
	Checkweigher with Linear Thrust Reject Device (Includes: Infeed, scale, and outfeed conveyors. All conveyors same length.)	36	42	100, 200	Min Length: 6 in Max Length (30ppm): 32 in Max Length (60ppm): 22 in
SST, Ind Welded					
SST, Food Grade Welded					
36		48	100, 200	Min Length: 6 in Max Length (30ppm): 36.5 in Max of 54ppm	AL, Ind Welded
					SST, Ind Welded
					SST, Food Grade Welded
36		54	100, 200	Min Length: 6 in Max Length (30ppm): 41.5 in Max of 48ppm	AL, Ind Welded
					SST, Ind Welded
36		60	100, 200	Min Length: 6 in Max Length (30ppm): 46 in Max of 44ppm	AL, Ind Welded
					SST, Ind Welded
					SST, Food Grade Welded

Additional configurations, sizes, and capacities are available upon request

IN-MOTION WEIGHING



Diverter

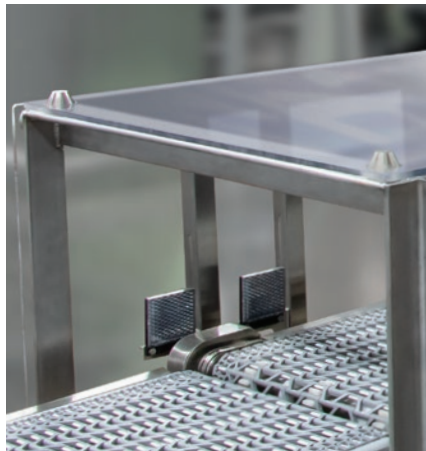

Draftshield



Stack light accessory



Guide rails

MotoWeigh® Metal Detector



Approvals



Part Number/Price

Part #	Main Systems	Price
Consult	Please consult factory for configuration and pricing	Consult

Options/Accessories

Part #	Main Systems	Price
200804	Caster package, MotoWeigh set of 4 - 2 swivel and 2 fixed casters for MotoWeigh metal detection conveyors	\$4,900.00
186279	Information tower includes buzzer	\$1,500.00
186280	Remote electronics with up to 100 ft of cable	\$1,315.00
186281	AC power conditioner in NEMA Type 4X enclosure	\$3,040.00
186282	PLC module for Ethernet IP interface (factory installed only)	\$2,410.00
186284	Preventive kit	\$1,010.00

Ferrous (Mild Steel) Test Wands

168370	1.0 mm ferrous (mild steel) test wand	\$19.25
168383	1.2 mm ferrous (mild steel) test wand	\$19.25
168384	1.5 mm ferrous (mild steel) test wand	\$19.25
168385	1.8 mm ferrous (mild steel) test wand	\$19.25
168386	2.0 mm ferrous (mild steel) test wand	\$19.25
168387	2.2 mm ferrous (mild steel) test wand	\$19.25
168388	2.5 mm ferrous (mild steel) test wand	\$19.25
168389	2.8 mm ferrous (mild steel) test wand	\$19.25
168390	3.0 mm ferrous (mild steel) test wand	\$19.25
168391	3.1 mm ferrous (mild steel) test wand	\$19.25
168392	3.25 mm ferrous (mild steel) test wand	\$19.25
168393	3.5 mm ferrous (mild steel) test wand	\$19.25
168394	4.0 mm ferrous (mild steel) test wand	\$19.25
168395	4.5 mm ferrous (mild steel) test wand	\$19.25

Non-Ferrous (Brass) Test Wands

168411	1.0 mm non-ferrous (brass) test wand	\$19.25
168413	1.2 mm non-ferrous (brass) test wand	\$19.25
168414	1.5 mm non-ferrous (brass) test wand	\$19.25
168415	1.8 mm non-ferrous (brass) test wand	\$19.25
168416	2.0 mm non-ferrous (brass) test wand	\$19.25
168418	2.2 mm non-ferrous (brass) test wand	\$19.25
168420	2.5 mm non-ferrous (brass) test wand	\$19.25
168421	2.8 mm non-ferrous (brass) test wand	\$19.25
168422	3.0 mm non-ferrous (brass) test wand	\$19.25
168423	3.2 mm non-ferrous (brass) test wand	\$19.25
168424	3.5 mm non-ferrous (brass) test wand	\$19.25
168425	4.0 mm non-ferrous (brass) test wand	\$19.25
168426	4.5 mm non-ferrous (brass) test wand	\$19.25
168427	5.0 mm non-ferrous (brass) test wand	\$19.25

Standard Features

Software

- Four levels of security
- Easy setup and product learning
- Easily change product boundaries/rejection
- One touch log reporting
- Eight fields of data recorded on large hard drive
- USB, Ethernet and RS485 communication ports
- Up to 97 products
- English or Spanish

Hardware

- 7-inch color touchscreen interface
- 304 stainless steel construction
- NEMA Type 4X, 304 stainless steel housing and enclosure
- IP66 rated
- Easily removable belt
- Adjustable foot pads or optional casters
- Single-point junction box
- Anti-static UHMW slider bed
- Variable speed control

Options

- Reject mechanism
- Paddle
- Linear
- Drop
- Lock box
- IP69K
- Meets HACCP requirements
- Ferrous, non-ferrous and 316 stainless steel test wands; individual wands and kits
- LED communication tower
- Audible alarms
- Caster package
- Guide rails
- AC power conditioner

Specifications

Construction:

304 stainless steel

Display:

7-inch color touchscreen

Language Support:

English and Spanish

Inputs:

Eight configurable (for photo eyes, remote emergency stop, etc.) that can be set to active high or active low

Outputs:

Nine programmable (for reject mechanism, system faults, system warnings, etc.)

Speed:

Up to 120 ft/minute depending on configuration

Operating Temperature:

Integral control 14 °F to 120 °F (-10 °C to 49 °C)

Storage Temperature:

14 °F to 175 °F (-10 °C to 80 °C)

Maximum Operating Altitude:

6,561 ft (2,000 m)

Power Requirements:

100 to 240 VAC, 50 or 60 Hz

IN-MOTION
WEIGHING

MotoWeigh® Metal Detector

Options/Accessories

Part #	Main Systems	Price
316 Stainless Steel Test Wands		
168428	1.5 mm 316 stainless steel test wand	\$19.25
168429	1.8 mm 316 stainless steel test wand	\$19.25
168430	2.0 mm 316 stainless steel test wand	\$19.25
168431	2.2 mm 316 stainless steel test wand	\$19.25
168432	2.5 mm 316 stainless steel test wand	\$19.25
168433	2.8 mm 316 stainless steel test wand	\$19.25
168434	3.0 mm 316 stainless steel test wand	\$19.25
168435	3.1 mm 316 stainless steel test wand	\$19.25
168436	3.4 mm 316 stainless steel test wand	\$19.25
168437	4.0 mm 316 stainless steel test wand	\$19.25
168438	4.5 mm 316 stainless steel test wand	\$19.25
168439	5.0 mm 316 stainless steel test wand	\$19.25
168440	5.5 mm 316 stainless steel test wand	\$19.25
168441	6.0 mm 316 stainless steel test wand	\$19.25
Test Wand Kits		
168445	Master kit (ferrous 1.0 to 4.5 mm, non-ferrous 1.0 to 5 mm, 316 stainless steel 1.5 to 6.0 mm)	\$1,500.00
168442	Ferrous kit (1.0 to 4.5 mm)	\$500.00
168443	Non-ferrous kit (1.0 to 5.0 mm)	\$500.00
168444	316 stainless steel kit (1.5 to 6.0 mm)	\$500.00

IN-MOTION
WEIGHING

MotoWeigh® Cascade Checkweigher

Gravity Drop Checkweigher



Standard Features

Software

- Single part drop detection (part outside of the bag)
- Statistical information
- Store up to 500 different products

Hardware

- Mild steel construction
- Electrostatic dissipative powder coating
- 920j® wall mount
- Air regulator
- Bimba® air cylinders
- MAC® solenoid valves

Options

- LED communication tower
- Audible alarm
- Draft shield

Specifications

Construction:

- Mild steel
- Stainless steel

Capacity:

1.5 lb (680.4 g)

Maximum Container Size:

(L x W x H)
7.00 x 7.00 x 1.50 in

Accuracy:

±0.00044 lb (0.2 g)

Maximum Product Throughput:

45 parts per minute*

Cylinder Stroke:

1.75 in

**Variable based on product size, cylinder stroke, and scale accuracy*

Part Number/Price

Part #	Main Systems	Price
212750	MotoWeigh Cascade Checkweigher and control panel mild steel	\$9,375.00
212751	MotoWeigh Cascade Checkweigher and control panel stainless steel	\$10,250.00

Options/Accessories

Part #	Description	Price
185808	Red and green communication tower	\$775.00
186577	Red, green and alarm communication tower	\$950.00

Motoweigh® Integrator

IN-MOTION
WEIGHING



Standard Features

Software

- Password protected user logins
- Real-time statistical information
- Product report
- Statistical report
- Parameter report
- User report
- Store up to 1,000 different products
- Five -zone classification
- Configurable reject output
- Conveyor control output

Control Panel

- Stainless steel enclosure
- Panel mount
- 24 VDC power supply
- 16 Opto 22 relays
- Terminal blocks for easy wiring

Options

- One, three or five -zone communication tower
- Audible alarm (non-washdown only)

Specifications

Construction:

Stainless steel

Control Panel Size:

16 x 16 x 8 in

Power Configuration:

115 to 230 VAC single phase, 50/60 Hz

Part Number/Price

Part #	Main Systems	Price
206440	1280 panel mount with MotoWeigh software, with cord grips	\$7,600.00

Options/Accessories

Part #	Description	Price
185803	Alarm communication tower	\$435.00
185804	Red communication tower	\$480.00
185805	Three-zone communication tower	\$1,120.00
185806	Three-zone and alarm communication tower	\$1,390.00
185807	Five-zone communication tower	\$1,540.00

A&D Inspection

In-Motion Checkweigher and Metal Detector



AD-4961 Series Checkweigher

IN-MOTION
WEIGHING

	AD-4961-600-1224 Specifications	AD-4961-2KD-2035 Specifications	AD-4961-6K-3050 Specifications
Capacity	600 g	500 g/2,000 g	6,000 g
Resolution	0.1 g	0.1 g	0.1 g
Construction	IP65 stainless steel construction with ABS resin display	IP65 stainless steel construction with ABS resin display	IP65 stainless steel construction with ABS resin display and stainless steel control box and base
Aperture Sizes	N/A	N/A	N/A
Display	7 in color touchscreen	7 in color touchscreen	7 in color touchscreen
Alarm	Included	Included	Included
Configurations	Checkweigher or conveyor scale	Checkweigher or conveyor scale	Checkweigher or conveyor scale
Speed	Up to 240 ft per minute	Up to 240 ft per minute	Up to 240 ft per minute
Max Throughput	150 pcs per min	150 pcs per min	100 pcs per min
Belts	Food grade urethane belt	Food grade urethane belt	Food grade urethane belt
Belts Width	4.7 in	7.8 in	11.8 in
Conveyor Length	14.2 in	13.7 in	19.6 in
Recorded Items	1,000 items (ten groups x 100 items)	1,000 items (ten groups x 100 items)	1,000 items (ten groups x 100 items)
Communication	Modbus TCP, Modbus RTU, RS-232, Ethernet TCP/IP (PostScript Printer), USB (for PostScript Printer, USB memory, data storage, image import use)	Modbus TCP, Modbus RTU, RS-232, RS-485, Ethernet TCP/IP (PostScript Printer), USB (for PostScript Printer, USB memory, data storage, image import use)	Modbus TCP, Modbus RTU, RS-232, RS-485, Ethernet TCP/IP (PostScript Printer), USB (for PostScript Printer, USB memory, data storage, image import use)
Input/Output	External input for four non-voltage contact points External output for eight relay points	External input for four non-voltage contact points External output for eight relay points	External input for four non-voltage contact points External output for eight relay points
Power Configuration	100 VAC-240 VAC (+10%/-15%) single phase, 50/60 Hz; 180 VA	100 VAC-240 VAC (+10%/-15%) single phase, 50/60 Hz; 180 VA	100 VAC-240 VAC (+10%/-15%) single phase, 50/60 Hz; 180 VA
Operating Temperature	23°F to 104°F (-5°C to 40°C)	23°F to 104°F (-5°C to 40°C)	23°F to 104°F (-5°C to 40°C)
External Dimensions	(L x W x H) 26 x 23.7 x 28.1 in to 33.9 in	(L x W x H) 27.5 x 25.9 x 27.9 in to 33.8 in	(L x W x H) 39.5 x 28.9 x 28.3 in to 34.2 in



Breeze Break



Tower Light

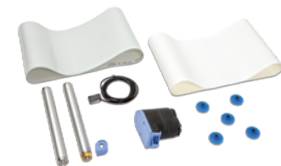

Maintenance Kit

A&D Inspection AD-4961 Series

In-Motion Conveyor Scale, Checkweigher and Metal Detector

Part Number/Price

AD-4961A 600g		
Part #	Checkweigher	Price
220816	EZiCheck checkweigher 600 g	\$24,700.00
Part #	Rejector	Price
186318	EZiCheck 600 g air jet reject with two nozzles	\$6,500.00

Assembly is required

Options/Accessories

Part #	Options / Accessories	Price
221113	EZiCheck 600 g breeze break	\$1,100.00
176622	CW extension leg kit - set of four (up to 40 in)	\$495.00
186320	Maintenance kit 600 g	\$3,000.00
203601	EZ caster package	\$1,850.00
220817	EZiCheck flat guide rails for 600 g weighing conveyor	\$950.00
220818	EZiCheck flat guide rails for 600 g infeed conveyor	\$950.00
221114	EZiCheck 600 g lower breeze break	

Part Number/Price

AD-4961-2K-2035 2 kg		
Part #	Checkweigher	Price
220725	EZiCheck checkweigher 2 kg	\$27,000.00
Part #	Rejector	Price
Consult	EZiCheck 2 kg dual channel reject flipper	Consult
221115	Air jet rejector (two nozzles)	\$7,600.00
220775	EZiCheck 2 kg single channel drop rejector	\$7,800.00
220776	Drop rejector stand	\$2,000.00

Assembly is required

Options/Accessories

Part #	Options / Accessories	Price
176614	EZiCheck-01 display stand	\$350.00
176612	Tower light 3 zone, must buy AD-4691-01	\$750.00
221113	EZiCheck-11 upper breeze break	\$1,100.00
221116	EZiCheck-12 lower breeze break	\$800.00
176618	2 kg transfer plate, single	\$175.00
176619	2 kg Product guides (infeed and conveyor), set of 2	\$800.00
176622	CW extension leg kit - set of four (up to 40 in)	\$495.00
179427	Maintenance kit 2 kg	\$3,000.00
192920	Conveyor connection kit	\$51.00
203601	EZ caster package	\$1,850.00

Part Number/Price

AD-4961-6K-3050 6 kg		
Part #	Checkweigher	Price
220777	EZiCheck checkweigher 6 kg	\$33,000.00
Part #	Rejector	Price
176609	EZiCheck 6 kg push ram rejector	\$11,000.00
Consult	Flipper rejector	Consult
Consult	Drop rejector	Consult

Assembly is required

Options/Accessories

Part #	Options / Accessories	Price
176614	EZiCheck-01 display stand	\$350.00
215272	6 kg product guides, set of 2 (infeed or conveyor)	\$850.00
215274	6 kg breeze break	\$2,930.00
176612	Tower light 3 zone, must buy AD-4691-01	\$750.00
176622	CW extension leg kit - set of four (up to 40 in)	\$495.00
186322	Maintenance kit 6 kg	\$3,300.00
203601	EZ caster package	\$1,850.00

IN-MOTION
WEIGHING

RT-M

Roller Top Scale



Part Number/Price

Part #	Description	Price
201732	MotoWeigh roller top scale	\$6,900.00
220912	Roller conveyor scale painted 680 version	\$6,400.00

* For 880/880 Plus specifications please see page 512

Standard Features

- Integrated overload protection
- 4 load cell system
- Mild steel powder-coated frame
- Non- powder-coated rollers
- Consult factory for custom sizes/capacities

RT-M Specifications

Dimensions:

(L × W × H)

54 × 36 × 30 in with +/- 2.5 in height adjustment

Capacity:

100 × 0.05 lb

Approvals:

Not available on RT-M

880 Indicator Specifications

Power:

Line voltages: 100 to 240 VAC

Excitation Voltage:

10 VDC (+/- 5 VDC), 16 × 350 ohm or 32 × 700 ohm load cells

Digital I/O:

Four I/O onboard, primary keys, pseudo functions, batching functions

Communication Ports:

RS-232 full duplex or RS-485 half duplex; USB micro A/B connector 2.0; Ethernet TCP/IP

Display:

LED, 0.56 in (14 mm), six-digit, 14-segment with decimal or comma

Dimensions:

(L × W × H)

Universal: 9.87 × 4.00 × 9.38 in
(248 × 102 × 235 mm)

Approvals:

NTEP CC 13-080 Class III/IIIL, 10,000d

Measurement Canada AM-5931C

OIML R76/2006-A-NL1-18.23 Class III, 10,000d

680 Indicator Specifications

Power:

Line voltages: 100 to 240 VAC

Frequency: 50 to 60 Hz

Excitation Voltage:

10 VDC (± 5 VDC), 8 × 350 ohm or 16 × 700 ohm load cells

Digital I/O:

Four configurable I/O - 5V logic

Communication Ports:

Two RS-232 (three-wire)

RS-485/422 (five-wire)

Micro USB (device)

Ethernet TCP/IP (10/100)

Display:

Seven 0.8 in tall, seven-segment digits

Dimensions:

(L × W × H)

11.58 × 4.05 × 8.57 in

(294 × 103 × 218 mm)

Approvals:

NTEP 19-021, Class III/IIIL, 10,000d

Measurement Canada AM-6121C

OIML R76/2006-A-NL1-19.56

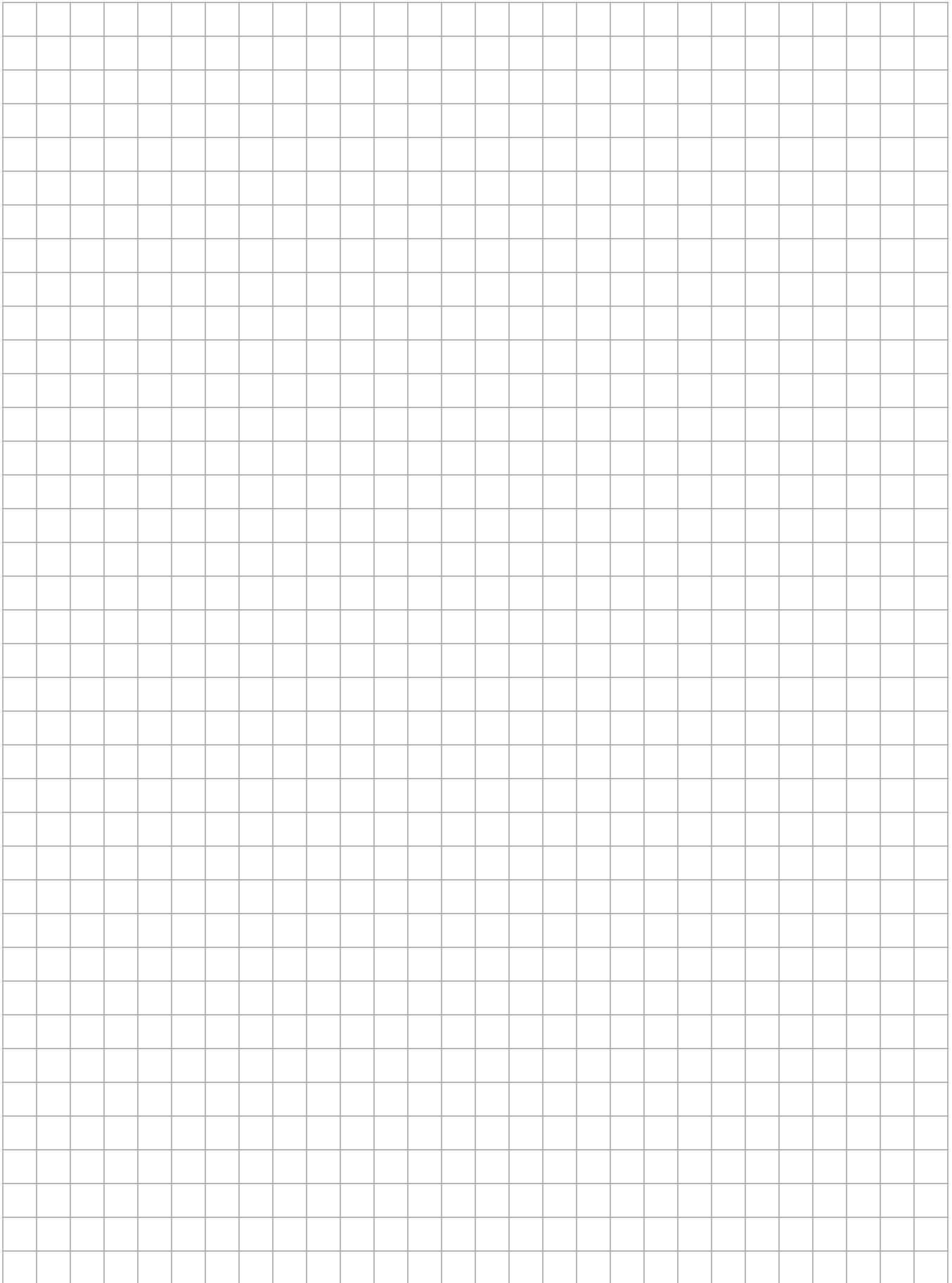

**IN-MOTION
WEIGHING**

