

# Pipe Lever Scales

---

## TABLE OF CONTENTS

Pipe Lever Scale.....	830
Pipe Lever Scale Questionnaire .....	831

*Product names, logos, brands and other trademarks featured or referred to within this publication are the property of their respective trademark holders.*

# Pipe Lever Scale

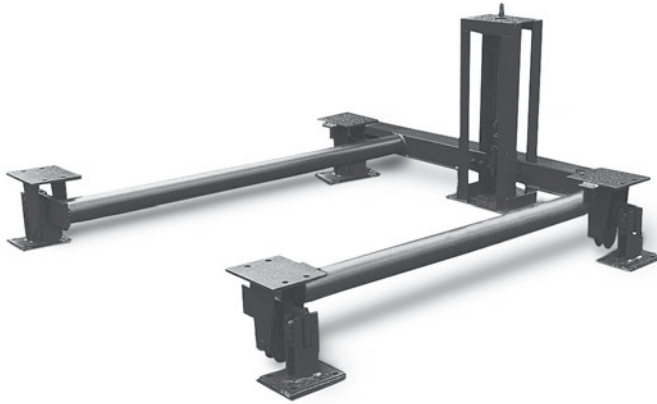

## Approvals



Measurement  
Canada  
Approved



## Part Number/Price

Part #	Dimensions	Est. Weight	Price
<b>25,000 lb</b>			
29587	62 5/8 × 62 5/8 in	532 lb	\$4,500.00
29586	60 1/2 × 66 in	528 lb	\$4,500.00
29588	66 1/2 × 91 in	640 lb	\$4,500.00
29589	64 × 64 in	538 lb	\$4,500.00
35008	62 × 92 in	561 lb	\$4,500.00
35009	62 × 105 in	720 lb	\$4,500.00
40409	72 × 72 in	618 lb	\$4,500.00
83433	64 3/4 × 64 3/4 in	567 lb	\$4,500.00
<b>25,000 lb Stainless Steel</b>			
46264	62 5/8 × 62 5/8 in	405 lb	\$9,900.00
46265	60 1/2 × 66 in	550 lb	\$9,900.00
46266	66 1/2 × 91 in	610 lb	\$9,900.00
50172	64 × 64 in	550 lb	\$9,900.00
50173	62 × 92 in	680 lb	\$9,900.00
50174	62 × 105 in	720 lb	\$9,900.00
<b>40,000 lb</b>			
39152	5 × 5 ft	1,885 lb	\$11,200.00
39153	6 × 6 ft	1,975 lb	\$11,200.00
39154	7 × 7 ft	2,220 lb	\$11,200.00
39155	8 × 8 ft	2,310 lb	\$11,200.00
39156	9 × 9 ft	2,545 lb	\$11,200.00
39157	10 × 10 ft	2,635 lb	\$11,200.00
<b>50,000 lb</b>			
39158	5 × 5 ft	2,010 lb	\$11,200.00
39159	6 × 6 ft	2,120 lb	\$11,200.00
39160	7 × 7 ft	2,385 lb	\$11,200.00
39161	8 × 8 ft	2,495 lb	\$11,200.00
39162	9 × 9 ft	2,750 lb	\$11,200.00
39163	10 × 10 ft	2,860 lb	\$11,200.00

## Standard Features

- NTEP Certified and Measurement Canada Approved models available
- RL20000 alloy steel load cell standard (prices include load cell and ITCM load cell assembly)
- Mild steel construction, black paint finish
- Stainless steel, hermetically sealed load cells available
- Custom sizes and capacities available from 5,000 to 60,000 lb

## Specifications

### End Load Capacity:

100% full scale

### mV/V Output:

1.50 to 1.87 mV/V nominal

### Cable Length:

20 ft (6.1 m)

### Warranty:

One-year limited

### Approvals:

NTEP CC 94-126

Class III/IIII

Measurement Canada Approved, AM-5114,  
Legal For Trade on sizes greater than 1.6 m,  
or a capacity greater than 10,000 kg



Custom sizes fit your tank/hopper system for fewer modifications and less installation time.

# Pipe Lever Scale Questionnaire



Company \_\_\_\_\_

Name \_\_\_\_\_ Date \_\_\_\_\_

Phone \_\_\_\_\_ Fax \_\_\_\_\_ Email \_\_\_\_\_

	5K/10K Total Load*		25K Total Load*		30K Total Load*		40K/60K Total Load*	
	Standard	Minimum	Standard	Minimum	Standard	Minimum	Standard	Minimum
A	–	48.00 in	–	48.00 in	–	60.00 in	–	60.00 in
B	–	48.00 in	–	48.00 in	–	60.00 in	–	60.00 in
C	12.25 in	4.50 in	15.50 in	7.00 in	15.62 in	7.00 in	18.00 in	7.00 in
D	6.00 in	6.00 in	9.50 in	8.75 in	9.50 in	8.75 in	13.00 in	12.00 in
E	6.00 in	6.00 in	9.50 in	8.75 in	9.50 in	8.75 in	13.00 in	12.00 in
F	8.62 in	8.62 in	13.56 in	13.56 in	13.81 in	13.81 in	18.18 in	18.18 in
G	4.50 in	3.50 in	6.50 in	4.75 in	6.50 in	4.75 in	9.25 in	6.50 in
H	4.50 in	3.50 in	6.50 in	4.75 in	6.50 in	4.75 in	9.25 in	6.50 in
J	24.00 in	24.00 in	32.25 in	32.25 in	32.25 in	32.25 in	37.25 in	37.25 in

A x B must be equal to or less than 64 square feet. If, over consult factory.

\* Live and dead load

A x B must be equal to or less than 100 square feet. If, over consult factory.

A x B must be equal to or less than 100 square feet. If, over consult factory.

A x B must be equal to or less than 100 square feet. If, over consult factory.

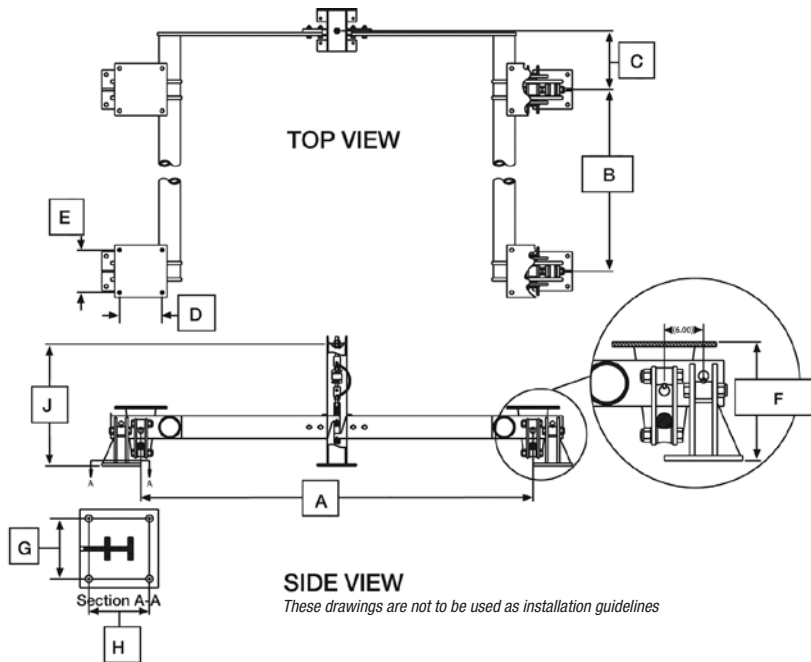

A	
B	
C	
D+	
E+	
F	
G**	
H**	
J	

\*\* Stand hole dimensions +Chair hole dimensions.

Capacity:  5K  10K  25K  30K  40K  50K  60K

Material:  Stainless Steel  Mild Steel

NTEP Required:  Yes  No

Finish: \_\_\_\_\_

Load Cell:  Mild Steel  Stainless Steel Hermetically Sealed  
 Model \_\_\_\_\_ Model \_\_\_\_\_

Form #0652 New 08/2021

PIPE LEVER SCALES