

# Crane Scales

## TABLE OF CONTENTS

<b>MSI-3460 Challenger 3</b> .....	<b>688</b>
<i>Crane Scale</i>	
<b>MSI-4260 Port-A-Weigh</b> .....	<b>690</b>
<i>Crane Scale</i>	
<b>MSI-4260 IS Port-A-Weigh</b> .....	<b>692</b>
<i>Intrinsically Safe Crane Scale</i>	
<b>MSI-4260M Port-A-Weigh</b> .....	<b>693</b>
<i>Industrial Crane Scale</i>	
<b>MSI-4260M Port-A-Weigh</b> .....	<b>695</b>
<i>Marine Crane Scale</i>	
<b>MSI-4300 Port-A-Weigh Plus</b> .....	<b>696</b>
<i>Crane Scale</i>	
<b>MSI-9600HT Hi-Torque Port-A-Weigh Plus</b> .....	<b>697</b>
<b>MSI-6360 Trans-Weigh</b> .....	<b>699</b>
<b>MSI-7300 Dyna-Link 2</b> .....	<b>701</b>
<i>Digital Tension Dynamometer</i>	
<b>MSI Dyna-Clamp</b> .....	<b>703</b>
<i>Tension Meter</i>	
<b>MSI Clamp-On</b> .....	<b>704</b>
<i>Load Cell</i>	
<b>MSI Load Pin Sensors</b> .....	<b>705</b>
<b>MSI Load Pin Questionnaire</b> .....	<b>706</b>
<b>MSI Shear Web</b> .....	<b>707</b>
<i>Load Cell</i>	
<b>MSI Tension Link</b> .....	<b>708</b>
<i>Load Cell</i>	
<b>Shackle Dimensions</b> .....	<b>709</b>
<b>MSI-8000</b> .....	<b>710</b>
<i>RF Remote Display</i>	
<b>MSI-8000HD</b> .....	<b>711</b>
<i>Indicator/Remote Display</i>	
<b>MSI-8004HD</b> .....	<b>713</b>
<i>Indicator/RF LED Remote Display</i>	
<b>MSI Scoreboards Wireless RF</b> .....	<b>715</b>
<i>Featuring LaserLight2 Remote Displays</i>	
<b>RF TRANSCEIVERS</b>	
<b>TranSend™ MSI-7000</b> .....	<b>716</b>
<i>Wireless Load Cell Interface System</i>	
<b>TranSend™ MSI-7001</b> .....	<b>718</b>
<i>Wireless Load Cell Interface System</i>	
<b>TranSend™ MSI-7000HD</b> .....	<b>720</b>
<i>Wireless Load Cell Interface System</i>	
<b>TranSend™ MSI-7001HD</b> .....	<b>721</b>
<i>Wireless Load Cell Interface System</i>	
<b>ScaleCore Webserver</b> .....	<b>722</b>
<i>For use with ScaleCore based MSI brand scales and indicators</i>	

**OVERHEAD WEIGHING**

The following product names, logos, brands and other trademarks featured or referred to within this publication are the property of their respective trademark holders.

# MSI-3460 Challenger 3

Crane Scale



## Approvals



## Standard Features

- Crane scale unit with five-digit, 1.5 in (38 mm) LED display
- Top lifting eye and bottom swivel hook
- Lb/kg switch selectable
- Six volt rechargeable battery and universal 115/230 VAC, 50/60 Hz battery charger (NA plug standard)
- Meets or exceeds OSHA, ANSI, ASME and other safety design standards (5:1 Ultimate Safety Factor)
- NTEP Certified (250 to 10,000 lb capacities)

## Part Number/Price

Part #	Description	Resolution	Est. Weight	Price
139102	250 lb/500 lb (125 kg/250 kg) cap F/A	0.1 lb (0.05 kg) 0.2 lb (0.1 kg)	22 lb	\$2,090.00
139103	1,000 lb/2,000 lb (500 kg/1,000 kg) cap F/A	0.5 lb (0.2 kg) 1 lb (0.5 kg)	22 lb	\$2,200.00
139104	5,000 lb/10,000 lb (2,500 kg/5,000 kg) cap F/A	2 lb (1 kg) 5 lb (2 kg)	39 lb	\$2,760.00
139105	15,000 lb (7,000 kg) cap F/A	5 lb (2 kg)	67 lb	\$3,770.00
139110	250 lb/500 lb (125 kg/250 kg) cap F/A (with RF modem for connectivity to model MSI-8000 and remote)	0.1 lb (0.05 kg) 0.2 lb (0.1 kg)	22 lb	\$2,280.00
139111	1,000 lb/2,000 lb (500 kg/1,000 kg) cap F/A (with RF modem for connectivity to model MSI-8000 and remote)	0.5 lb (0.2 kg) 1 lb (0.5 kg)	22 lb	\$2,430.00
139112	5,000 lb/10,000 lb (2,500 kg/5,000 kg) cap F/A (with RF modem for connectivity to model MSI-8000 and remote)	2 lb (1 kg) 5 lb (2 kg)	39 lb	\$2,920.00
139113	15,000 lb (7,000 kg) cap F/A (with RF modem for connectivity to model MSI-8000 and remote)	5 lb (2 kg)	67 lb	\$4,010.00
176909	250 lb/500 lb (125 kg/250 kg) cap F/A with Wi-Fi	0.1 lb (0.05 kg) 0.2 lb (0.1 kg)	22 lb	\$2,340.00
176910	1,000 lb/2,000 lb (500 kg/1,000 kg) cap F/A with Wi-Fi	0.5 lb (0.2 kg) 1 lb (0.5 kg)	22 lb	\$2,460.00
176911	5,000 lb/10,000 lb (2,500 kg/5,000 kg) cap F/A with Wi-Fi	2 lb (1 kg) 5 lb (2 kg)	39 lb	\$2,990.00
176912	15,000 lb (7,000 kg) cap F/A with Wi-Fi	5 lb (2 kg)	67 lb	\$4,080.00

## Options

(Contact MSI for application consultation)

- Rugged remote control (control for On/Off, Zero, Tare and other functions)
- RF modem install for connectivity to MSI-8000, MSI-8000HD RF, MSI-8004HD RF remote display, TranSend and LaserLight2 remote display. Typically 100 to 300 ft, line of sight; for longer range consult factory.
- Universal direct power supply (115/230 VAC)
- Audible alarm
- Wi-Fi communication is available for specialty applications
- OIML and CE approved versions available, consult for more information

## Specifications

### Accuracy:

± (0.1% +1 d) of applied load

### Resolution:

2,000 to 3,750 d standard  
(Up to 10,000 d available)

### Enclosure:

NEMA Type 4, IP65, powder coated cast aluminum

### Lifting Eye & Hook:

Crosby® or equivalent with 360° non-bearing swivel hook

### Design Overload:

200% Safe / 500% Ultimate

### Functions:

Power: Turns unit ON or OFF  
Zero: Zeros applied load up to 100% of capacity (limited range in NTEP/OIML configurations)  
Tare: Tares applied load and displays weight in Net mode  
User: Programmable as test, units, net/gross, total, peak hold and setpoints

### Display:

5-digit, 1.5 in (38 mm) LED with programmable brightness control

### Displayable Units:

Pounds or kilogram selectable

### Annunciators:

COZ, Net, Gross, Total, Peak, Low Battery, lb/kg, Motion, Setpoints, ACK IN, ACK OUT, RF

### Power:

6 Volt rechargeable battery. 115/230 VAC battery charger is included

### Operating Time:

Up to 80 hours between charging with typical use. Less with optional RF Model

### Operating Temperature:

14 °F to 104 °F (-10 °C to 40 °C)  
Legal for Trade: 14 °F to 104 °F (-10 °C to 40 °C)

### Auto-Off Mode:

Select for 15, 30, 45, 60 minutes or Off

### Auto Sleep Mode:

Power down during non-use and power up with weight change or any key press

### Service Counters:

Counts number of lifts over percentage of capacity and lifts over capacity

### Calibration:

Digital

### Filtering:

OFF, LO, HI-1, HI-2 selectable

### Warranty:

One-year limited

### Approvals:

NTEP CC 86-021 (250 thru 10,000k only)  
OIML R76/2006-A-NL1-21.36  
CE Marked

OVERHEAD WEIGHING

# MSI-3460 Challenger 3

Crane Scale

## Options/Accessories

Part #	Description	Est. Weight	Price
140049	Battery assembly, 6 volt rechargeable	3 lb	\$145.00
139152	Universal 115/230 VAC, 50/60 Hz battery charger (NA plug standard)	5 lb	\$190.00
139153	Battery charger 115/230 VAC, 50/60 Hz (EC plug standard)	5 lb	\$190.00
197201	Battery charger, 115 VAC, 50/60 Hz (NA plug standard) CEC compliant	-	\$235.00
149549	Universal 115/230 VAC 50/60 Hz (NA plug standard) battery charger for MSI-8000 remote display	3 lb	\$155.00
178004	LaserLight2, 4 in (101 mm) six-digit RF scoreboard (requires MSI-3460 with RF modem)	21 lb	\$2,370.00
178006	LaserLight2, 6 in (152 mm) six-digit RF scoreboard (requires MSI-3460 with RF modem)	37 lb	\$2,810.00
Consult	AC power supply	-	\$310.00
140058	3460 AC conversion kit	-	\$445.00
Consult	Audible setpoint alarm	-	\$330.00
139395	Challenger retrofit to 3460 electronics	1 lb	\$1,110.00
139397	Challenger retrofit to 3460 RF electronics	-	\$1,280.00
173014	Rugged remote control (requires MSI-3460 with RF modem)	-	\$330.00
139381	MSI-8000 RF remote display (requires MSI-3460 with RF modem)	5 lb	\$1,320.00
153591	MSI-8000HD ScaleCore RF remote display (requires MSI-3460 with RF modem)	-	\$1,440.00
178281	MSI-8004HD AC, Red/Green 85~264 VAC, 47~440 Hz, 120~370 VDC	-	\$1,980.00

OVERHEAD  
WEIGHING

# MSI-4260 Port-A-Weigh

Crane Scale



## Approvals



## Standard Features

- Crane unit with five-digit, 1.2 in (30 mm) LED display
- Top lifting eye or shackle, bottom thrust bearing swivel hook
- 12 volt rechargeable battery and universal 115/230 VAC, 50/60 Hz battery charger (NA plug standard)

## Options

(Contact MSI for application consultation)

- Rugged remote control (control for On/Off, Zero, Tare and other functions)
- RF modem install for connectivity to MSI-8000, MSI-8000HD RF, MSI-8004HD RF remote display, TranSend and LaserLight2 remote display. Typically 100 to 300 ft, line of sight; for longer range consult factory
- Anti-heat shielding for high temperature applications
- Substitute bottom swivel hook with shackle
- Oversized top lifting eye or shackle
- Oversized bottom hook
- Universal direct power supply; 85 to 265 VAC, 47 to 440 Hz / 130 to 300 VDC
- Low headroom top adapter
- Audible alarm
- Wi-Fi communication is available for specialty applications
- Custom top and bottom interfaces
- Factory Mutual and ATEX approved intrinsically safe models available

## Part Number/Price

Part #	Description	Resolution	Est. Weight	Price
139460	500 lb (250 kg) F/A	0.2 lb (0.1 kg)	53 lb	\$4,520.00
139461	2,000 lb (1,000 kg) F/A	1.0 lb (0.5 kg)	53 lb	\$4,520.00
139462	5,000 lb (2,500 kg) F/A	1.0 lb (0.5 kg)	62 lb	\$4,620.00
139463	10,000 lb (5,000 kg) F/A	2.0 lb (1.0 kg)	62 lb	\$4,890.00
139464	20,000 lb (10,000 kg) F/A	5.0 lb (2.0 kg)	105 lb	\$6,540.00
139465	30,000 lb (15,000 kg) F/A	10 lb (5.0 kg)	125 lb	\$6,910.00
139466*	50,000 lb (25,000 kg) F/A	10 lb (5.0 kg)	235 lb	\$10,560.00
139467**	70,000 lb (35,000 kg) F/A	20 lb (10 kg)	270 lb	\$13,990.00
139468***	100,000 lb (50,000 kg) F/A	20 lb (10 kg)	420 lb	\$21,700.00

\* 490% of kg capacity

\*\* 475% of lb capacity/430% of kg capacity

\*\*\* 450% of kg capacity

## Specifications

### Accuracy:

± 0.1% +1 d of applied load

### Resolution:

3,000 to 5,000 d standard  
(Up to 10,000 d available)

### Enclosure:

NEMA Type 4, IP66 marine grade 356 alloy anodized cast aluminum

### Lifting Eye, Shackle & Hook:

Crosby® or equal with 360° thrust-bearing swivel hook

### Design Overload:

200% Safe / 500% Ultimate (except where noted)

### Functions:

Power: Turns Unit ON or OFF, Zero: Zeros applied load up to 100% of capacity (limited range in NTEP configuration), Tare: Tares applied load and displays weight in Net mode, F1: Programmable as TEST, UNITS, NET/ GROSS, TOTAL & PEAK HOLD

### Display:

Five digit, 1.2 in (30 mm) LED with programmable brightness control

### Displayable Units:

Pounds or kilograms selectable

### Annunciators:

COZ, Net, Gross, Total, Peak, Low Battery, lb/kg, Motion, Setpoints

### Power:

12 Volt rechargeable battery. 115/230 VAC battery charger is included.

### Operating Time:

Up to 200 hours between charging with typical use, less with optional RF modem

### Operating Temperature:

-40 °F to 122 °F (-40 °C to 50 °C)  
Legal for Trade: 14 °F to 104 °F (-10 °C to 40 °C)

### Auto-Off Mode:

Select for 15, 30, 45 minutes, 1 hour or Off

### Auto Sleep Mode:

Power down during non-use and power up with weight change or any key press

### Service Counters:

Counts number of lifts over percentage of capacity and lifts over capacity

### Calibration:

Digital

### Filtering:

OFF, LO, HI-1, HI-2 selectable

### Warranty:

One-year limited

### Approvals:

NTEP CC 89-090: 500 to 2,000 lb (250 to 1,000 kg)  
NTEP CC 88-098A2: 5,000 to 70,000 lb  
(2,000 to 35,000 kg)

# MSI-4260 Port-A-Weigh

Crane Scale

## Options/Accessories

Part #	Description	Est. Weight	Price
150971	Option kit 4260B RF modem (RF modem install for connectivity with MSI-8000 modem and rugged remote)	-	\$240.00
139381	MSI-8000 RF remote display (requires MSI-4260 equipped with RF modem)	5 lb	\$1,320.00
173014	RF rugged remote control (requires MSI-4260 equipped with RF modem)	-	\$330.00
153591	MSI-8000HD Remote Display, AC power and tilt bracket option	3 lb	\$1,440.00
178281	MSI-8004HD AC, Red/Green 85~264 VAC, 47~440 Hz, 120~370 VDC	-	\$1,980.00
159221	Universal crane scale transport cart	180 lb	\$1,250.00
178004	LaserLight2, 4 in (101 mm) six-digit RF scoreboard (requires MSI-4260 equipped with RF modem)	21 lb	\$2,370.00
178006	LaserLight2, 6 in (152 mm) six-digit RF scoreboard (requires MSI-4260 equipped with RF modem)	37 lb	\$2,810.00
Consult	AC direct power supply	-	\$535.00
Consult	Audible set point alarm	-	\$395.00
Consult	Anti-heat shield	-	\$1,010.00
152123	Retrofit kit 4260 to 4260B	8 lb	\$2,560.00
176956	Option kit, 4260B Wi-Fi	-	\$465.00
<b>Accessories</b>			
150367	Battery assembly, 12 V rechargeable	7 lb	\$135.00
138006	Universal 115/230 VAC, 50/60 Hz battery charger (NA plug standard)	4 lb	\$330.00
138007	Universal 115/230 VAC, 50/60 Hz battery charger (UK plug standard)	4 lb	\$330.00
138008	Universal 115/230 VAC, 50/60 Hz battery charger (EC plug standard)	4 lb	\$330.00
149549	Universal 115/ 230 VAC 50/60 Hz (NA plug standard) battery charger for MSI-8000 remote display	3 lb	\$155.00
<b>4260 Sub Hook with Shackle</b>			
Consult	500 to 10,000 lb, 6.5 ton shackle	-	Consult
Consult	20,000 to 30,000 lb, 17 ton shackle	-	Consult
Consult	50,000 lb, 25 ton shackle	-	Consult
Consult	70,000 lb, 40 ton shackle	-	Consult
Consult	100,000 lb, 55 ton shackle	-	Consult
<b>4260 Oversize Lifting Eye/Shackle</b>			
Consult	500 to 10,000 lb capacity	-	Consult
Consult	20,000 to 30,000 lb capacity, adapter with 25 ton shackle	-	Consult
Consult	50,000 to 70,000 lb capacity	-	Consult
Consult	100,000 lb capacity	-	Consult

OVERHEAD  
WEIGHING

# MSI-4260 IS Port-A-Weigh

Intrinsically Safe Crane Scale



## Approvals



## Standard Features

- Crane unit with five-digit, 1.2 in (30 mm) LED display
- Top lifting eye or shackle, bottom thrust bearing swivel hook
- 12 volt rechargeable battery and universal 115/230 VAC, 50/60 Hz battery charger (NA plug standard)

(Contact MSI for application consultation)

## Part Number/Price

Part #	Description	Resolution	Price
156013	500 lb (250 kg), Swivel Hook	0.2 lb (0.1 kg)	\$6,620.00
156014	2,000 lb (1,000 kg), Swivel Hook	1.0 lb (0.5 kg)	\$6,620.00
156015	5,000 lb (2,500 kg), Swivel Hook	1.0 lb (0.5 kg)	\$6,620.00
156016	10,000 lb (5,000 kg), Swivel Hook	2.0 lb (1.0 kg)	\$6,620.00
156017	20,000 lb (10,000 kg), Swivel Hook	5.0 lb (2.0 kg)	\$8,380.00
156018	30,000 lb (15,000 kg), Swivel Hook	10 lb (5.0 kg)	\$8,380.00
156019	50,000 lb (25,000 kg), Swivel Hook	10 lb (5.0 kg)	\$12,360.00
156020	70,000 lb (35,000 kg), Swivel Hook	20 lb (10 kg)	\$14,610.00
156021	100,000 lb (50,000 kg), Swivel Hook	20 lb (10 kg)	\$22,500.00

## Options/Accessories

Part #	Description	Price
170606	Battery Charger	\$305.00
167777	Spare Battery	\$275.00

## Specifications

### Accuracy:

± (0.1% +1 d) of applied load

### Resolution:

3,000 to 5,000 d standard  
(up to 10,000 d available)

### Enclosure:

NEMA Type 4, IP66 marine grade 356 alloy anodized cast aluminum

### Intrinsic Safety:

US Listings  
FM16US0156X  
IS / I, II, III / 1 / CDEFG / T4 Ta = -20°C to 50°C  
I / 0 / AEx ia / IIB / T4 Ta = -20°C to 50°C Ga  
20 / AEx ia / IIIC / T135°C Ta = -20 °C to 50 °C Da  
Canadian Listings  
FM16CA0092X  
IS / I / 1 / CD / T4 Ta = -10 °C to 50 °C  
IS / II, III / 1 / EFG / T4 Ta = -10 °C to 50 °C  
I / 0 / Ex ia / IIB / T4 Ta = -10 °C to 50 °C Ga  
20 / Ex ia / IIIC / T135°C Ta = -10 °C to 50 °C Da  
ATEX Listings  
FM16ATEX0038X  
II 1 G Ex ia IIB T4 Ga -10 °C = Ta = 50 °C  
II 1 D Ex ia IIIC T135°C Da -10 °C = Ta = 50 °C

### Lifting Eye, Shackle & Hook:

Crosby® or equal with 360° thrust-bearing swivel hook

### Design Overload:

200% Safe / 500% Ultimate (except where noted)

### Functions:

Power: Turns unit on or off  
Zero: Zeros applied load up to 100% of capacity (limited range in NTEP Certified configuration)  
Tare: Tares applied load and displays weight in Net mode F1: Programmable as test, units, net/gross, total and peak hold

### Display:

Five-digit, 1.2 in (30 mm) LED with programmable brightness control

### Displayable Units:

Pounds or kilograms selectable

### Annunciators:

COZ, Net, Gross, Total, Peak, Low Battery, lb/kg, Motion, Setpoints

### Power:

12 volt rechargeable battery  
115/230 VAC approved battery charger is included

### Operating Time:

Up to 200 hours between charging with typical use

### Auto-Off Mode:

Select for 15, 30, 45 minutes, 1 hour or Off

### Auto Sleep Mode:

Power down during non-use and power up with weight change or any key press

### Service Counters:

Counts number of lifts over percentage of capacity and lifts over capacity

### Calibration:

Digital

### Filtering:

OFF, LO, HI-1, HI-2 selectable

### Warranty:

One-year limited

### Approvals:

NTEP CC 19-122  
cFMus Approved  
CE Pending



# MSI-4260M Port-A-Weigh

Industrial Crane Scale



## Standard Features

- IP66 cast aluminum
- Top lifting eye or shackle, bottom thrust bearing swivel hook
- Five-digit, 1.75in (44.5mm) LCD with programmable brightness control
- Battery operated, six (6) D cell 1.5V alkaline batteries or
- 12 volt rechargeable battery (115/230 VAC battery charger is included)
- Meets or exceeds OSHA, ANSI, ASME and other safety design standards
- (5:1 Ultimate Safety Factor)
- NTEP Certified configuration

## Options

(Contact MSI for application consultation)

- Rugged remote control (control for On/Off, Zero, Tare and other functions)
- RF modem install for connectivity to MSI-8000, MSI-8000HD RF, MSI-8004HD RF remote display, TranSend and LaserLight2 remote display
- Wi-Fi communication is available for specialty applications
- Anti-heat shielding for high temperature applications
- Substitute bottom swivel hook with shackle
- Oversized top lifting eye or shackle
- Oversized bottom hook

- Universal direct power supply; 85 to 265 VAC, 47 to 440 Hz / 130 to 300 VDC
- Low headroom top adapter
- Audible alarm
- Custom top and bottom interfaces

## Specifications

### Accuracy:

± 0.1% +1 d of applied load

### Resolution:

Max NTEP Approved Class III: 2,500 Divisions  
Max NTEP Approved Class IIII: 5,000 Divisions  
Max Non-NTEP Approved: 10,000 Divisions

### Enclosure:

IP66 cast aluminum

### Lifting Eye, Shackle & Hook:

Crosby® or equal with 360° thrust-bearing swivel hook

### Design Overload:

200% Safe / 500% Ultimate (except where noted)

### Functions:

Power: Turns Unit ON or OFF  
Zero: Zeros applied load up to 100% of capacity (limited range in NTEP configuration),  
Tare: Tares applied load and displays weight in Net mode  
User: Programmable as test, total, unit, peak hold, net/gross, view total and print

### Display:

Five-digit, 1.75in (44.5 mm) LCD with programmable brightness control

### Displayable Units:

Pounds or kilograms selectable

### Annunciators:

COZ, Battery Level, Net, Total, lb/kg, Stability, RF and Setpoint LEDs

### Power:

Battery operated, six (6) D cell 1.5V alkaline batteries or 12 volt rechargeable battery (115/230 VAC battery charger is included)

### Operating Time:

Six (6) D Cell 1.5V alkaline batteries:  
Up to 1,000 hours of battery life with typical use, less with RF modem  
12 volt rechargeable battery: Up to 250 hours between charging with typical use, less with RF modem

### Operating Temperature:

-20 °F to 122 °F (-28 °C to 50 °C)  
Legal for Trade: 14 °F to 104 °F (-10 °C to 40 °C)

### Auto-Off Mode:

Powers off after the scale is not used for the set time (in minutes); 15, 30, 45, 60 or OFF selectable

### Auto Sleep Mode:

Power down during non-use after the set time (in minutes) and powers up with weight change or any key press; 5, 15, 30 or OFF selectable

### Service Counters:

Counts number of lifts over percentage of capacity and lifts over capacity

### Calibration:

Digital (procedure initiated by calibration switch)

### Filtering:

OFF, LO, HI-1 or HI-2 selectable

### Radio Link:

802.15.4 at 2.4 GHz

### Radio Effective Range:

Typically 100 to 300 ft line of sight

### Warranty:

One-year limited

### Approvals:

NTEP CC 19-122

## Approvals



## Part Number/Price

Part #	Description	Resolution	Est. Weight	Price
<b>4260M with LCD display, Swivel Hook, No RF, 12V SLA Battery</b>				
201951	500 lb (250 kg) with 12V Battery F/A	0.2 lb (0.1 kg)	53 lb	\$4,920.00
201953	2,000 lb (1,000 kg) with 12V Battery F/A	1.0 lb (0.5 kg)	53 lb	\$4,920.00
201954	5,000 lb (2,500 kg) with 12V Battery F/A	1.0 lb (0.5 kg)	62 lb	\$5,240.00
201955	10,000 lb (5,000 kg) with 12V Battery F/A	2.0 lb (1.0 kg)	62 lb	\$5,460.00
201956	20,000 lb (10,000 kg) with 12V Battery F/A	5.0 lb (2.0 kg)	105 lb	\$7,120.00
201957	30,000 lb (15,000 kg) with 12V Battery F/A	10 lb (5.0 kg)	125 lb	\$7,480.00
201958	50,000 lb (25,000 kg) with 12V Battery F/A	10 lb (5.0 kg)	235 lb	\$11,450.00
201959	70,000 lb (35,000 kg) with 12V Battery F/A	20 lb (10 kg)	270 lb	\$14,990.00
201960	100,000 lb (50,000 kg) with 12V Battery F/A	20 lb (10 kg)	420 lb	\$22,800.00
<b>4260M with LCD display, Swivel Hook, No RF, D-Cell Battery</b>				
201999	500 lb (250 kg) with D-Cell Battery F/A	0.2 lb (0.1 kg)	53 lb	\$4,920.00
202000	2,000 lb (1,000 kg) with D-Cell Battery F/A	1.0 lb (0.5 kg)	53 lb	\$4,920.00
202001	5,000 lb (2,500 kg) with D-Cell Battery F/A	1.0 lb (0.5 kg)	62 lb	\$5,240.00
202002	10,000 lb (5,000 kg) with D-Cell Battery F/A	2.0 lb (1.0 kg)	62 lb	\$5,460.00
202003	20,000 lb (10,000 kg) with D-Cell Battery F/A	5.0 lb (2.0 kg)	105 lb	\$7,120.00
202004	30,000 lb (15,000 kg) with D-Cell Battery F/A	10 lb (5.0 kg)	125 lb	\$7,480.00
202005	50,000 lb (25,000 kg) with D-Cell Battery F/A	10 lb (5.0 kg)	235 lb	\$11,450.00
202006	70,000 lb (35,000 kg) with D-Cell Battery F/A	20 lb (10 kg)	270 lb	\$14,990.00
202007	100,000 lb (50,000 kg) with D-Cell Battery F/A	20 lb (10 kg)	420 lb	\$22,800.00

OVERHEAD  
WEIGHING

# MSI-4260M Port-A-Weigh

Industrial Crane Scale

## Options/Accessories

Part #	Description	Est. Weight	Price
150971	Option kit 4260M RF modem (RF modem install for connectivity with MSI-8000 modem and rugged remote)	-	\$240.00
139381	MSI-8000 RF remote display (requires MSI-4260M equipped with RF modem)	5 lb	\$1,320.00
173014	RF rugged remote control (requires MSI-4260M equipped with RF modem)	-	\$330.00
153591	MSI-8000HD Remote Display, AC power and tilt bracket option (requires MSI-4260M equipped with RF modem)	3 lb	\$1,440.00
178281	MSI-8004HD AC, Red/Green 85~264 VAC, 47~440 Hz, 120~370 VDC	-	\$1,980.00
159221	Universal crane scale transport cart	180 lb	\$1,250.00
178004	LaserLight2, 4 in (101 mm) six-digit RF scoreboard (requires MSI-4260M equipped with RF modem)	21 lb	\$2,370.00
178006	LaserLight2, 6 in (152 mm) six-digit RF scoreboard (requires MSI-4260M equipped with RF modem)	37 lb	\$2,810.00
Consult	Option kit, 4260M Wi-Fi	-	Consult
<b>Accessories</b>			
150367	Battery assembly, 12V rechargeable	7 lb	\$135.00
138006	Universal 115/230 VAC, 50/60 Hz battery charger (NA plug standard)	4 lb	\$330.00
138007	Universal 115/230 VAC, 50/60 Hz battery charger (UK plug standard)	4 lb	\$330.00
138008	Universal 115/230 VAC, 50/60 Hz battery charger (EC plug standard)	4 lb	\$330.00
149549	Universal 115/ 230 VAC 50/60 Hz (NA plug standard) battery charger for MSI-8000 remote display	3 lb	\$155.00
<b>4260 Sub Hook with Shackle</b>			
Consult	500 to 10,000 lb, 6.5 ton shackle	-	Consult
Consult	20,000 to 30,000 lb, 17 ton shackle	-	Consult
Consult	50,000 lb, 25 ton shackle	-	Consult
Consult	70,000 lb, 40 ton shackle	-	Consult
Consult	100,000 lb, 55 ton shackle	-	Consult
<b>4260 Oversize Lifting Eye/Shackle</b>			
Consult	500 to 10,000 lb capacity	-	Consult
Consult	20,000 to 30,000 lb capacity, adapter with 25 ton shackle	-	Consult
Consult	50,000 to 70,000 lb capacity	-	Consult
Consult	100,000 lb capacity	-	Consult

OVERHEAD  
WEIGHING



# MSI-4260M Port-A-Weigh

Marine Crane Scale



## Standard Features

- IP66 cast aluminum
- Top lifting eye with lower link interface
- Five-digit, 1.75 in (45 mm) LCD with programmable brightness control
- Battery operated, six (6) D cell 1.5V alkaline batteries
- Meets or exceeds OSHA, ANSI, ASME and other safety design standards (5:1 Ultimate Safety Factor)
- NTEP Certified configuration

## Options

(Contact MSI for application consultation)

- Rugged remote control (control for On/Off, Zero, Tare and other functions)
- RF modem install for connectivity to MSI-8000, MSI-8000HD, MSI-8004HD, TranSend and LaserLight2 remote display. Typically 100 to 300 ft, line of sight; for longer range consult factory.
- Wi-Fi communication is available for specialty applications

## Specifications

### Accuracy:

± (0.1% +1d) of applied load

### Resolution:

Max NTEP Approved Class III: 2,500 Divisions  
Max NTEP Approved Class IIII: 5,000 Divisions  
Max Non NTEP Approved: 10,000 Divisions

### Enclosure:

IP66 cast aluminum

### Lifting Eye, Link & Hook:

Top lifting eye with lower link interface

### Design Overload:

200% Safe / 500% Ultimate

### Functions:

Power: Turns Unit ON or OFF  
Zero: Zeros applied load up to 100% of capacity (limited range in NTEP configuration),  
Tare: Tares applied load and displays weight in Net mode  
User: Programmable as test, total, unit, peak hold, net/gross, view total and print

### Display:

Five-digit, 1.75in (44.5 mm) LCD with programmable brightness control

### Displayable Units:

Pounds or kilograms selectable

### Annunciators:

COZ, Battery Level, Net, Total, lb/kg, Stability, RF and Setpoint LEDs

### Power:

Battery operated, six (6) D cell 1.5 V alkaline batteries

### Operating Time:

Up to 1,000 hours of battery life with typical use, less with RF modem option

### Operating Temperature:

-20° F to 122° F (-28 °C to 50 °C)  
Legal for Trade: 14 °F to 104 °F (-10 °C to 40 °C)

### Auto-Off Mode:

Powers off after the scale is not used for the set time (in minutes); 15, 30, 45, 60 or OFF selectable

### Auto Sleep Mode:

Power down during non-use after the set time (in minutes) and powers up with weight change or any key press; 5, 15, 30 or OFF selectable

### Service Counters:

Counts number of lifts over percentage of capacity and lifts over capacity

### Calibration:

Digital (procedure initiated by calibration switch)

### Filtering:

OFF, LO, HI-1 or HI-2 selectable

### Radio Link:

802.15.4 at 2.4 GHz

### Radio Effective Range:

Typically 100 to 300 ft line of sight

### Warranty:

One-year limited

### Approvals:

NTEP CC 19-122

## Approvals



## Part Number/Price

Part #	Description	Resolution	Est. Weight	Price
194593	5,000 lb	1.0 lb (0.5 kg)	58 lb	\$4,960.00
196908	5,000 lb w/RF	1.0 lb (0.5 kg)	58 lb	\$5,270.00

## Options/Accessories

Part #	Description	Est. Weight	Price
150971	Option kit 4260M RF modem (RF modem install for connectivity with MSI-8000 modem and rugged remote)	-	\$240.00
139381	MSI-8000 RF remote display (requires MSI-4260M equipped with RF modem)	5 lb	\$1,320.00
173014	RF rugged remote control (requires MSI-4260M equipped with RF modem)	-	\$330.00
153591	MSI-8000HD Remote Display, AC power and tilt bracket option (requires MSI-4260M equipped with RF modem)	3 lb	\$1,440.00
178281	MSI-8004HD AC, Red/Green 85~264 VAC, 47~440 Hz, 120~370 VDC	-	\$1,980.00
159221	Universal crane scale transport cart	180 lb	\$1,250.00
178004	LaserLight2, 4 in (101 mm) six-digit RF scoreboard (requires MSI-4260M equipped with RF modem)	21 lb	\$2,370.00
178006	LaserLight2, 6 in (152 mm) six-digit RF scoreboard (requires MSI-4260M equipped with RF modem)	37 lb	\$2,810.00
Consult	Option kit, 4260M Wi-Fi	-	Consult

OVERHEAD  
WEIGHING

# MSI-4300 Port-A-Weigh Plus

Crane Scale



Approvals



## Part Number/Price

Part #	Description	Resolution	Est. Weight	Price
138825	500 lb (250 kg) F/A	0.2 lb (0.1 kg)	53 lb	\$5,250.00
138826	2,000 lb (1000 kg) F/A	1.0 lb (0.5 kg)	53 lb	\$5,250.00
138827	5,000 lb (2500 kg) F/A	1.0 lb (0.5 kg)	62 lb	\$5,390.00
138828	10,000 lb (5000 kg) F/A	2.0 lb (1.0 kg)	62 lb	\$5,650.00
138069	20,000 lb (10,000 kg) F/A	5.0 lb (2.0 kg)	105 lb	\$7,040.00
138070	30,000 lb (15,000 kg) F/A	10 lb (5.0 kg)	125 lb	\$7,410.00
138071*	50,000 lb (25,000 kg) F/A	10 lb (5.0 kg)	235 lb	\$10,870.00
138072**	70,000 lb (35,000 kg) F/A	20 lb (10 kg)	270 lb	\$14,250.00
138073***	100,000 lb (50,000 kg) F/A	20 lb (10 kg)	420 lb	\$23,000.00

\* 490% of kg capacity

\*\* 475% of lb capacity/430% of kg capacity

\*\*\* 450% of kg capacity

## Options/Accessories

Part #	Description	Est. Weight	Price
159221	Universal crane scale transport cart	180 lb	\$1,250.00
Consult	Audible set point alarm	-	\$400.00
Consult	AC power supply	-	\$535.00
Consult	D cell battery option	-	Consult
<b>Accessories</b>			
150367	Battery assembly, 12 volt rechargeable	7 lb	\$135.00
138006	Universal 115/230 VAC, 50/60 Hz battery charger (NA plug standard)	4 lb	\$330.00
138007	Universal 115/230 VAC, 50/60 Hz battery charger (UK plug standard)	4 lb	\$330.00
138008	Universal 115/230 VAC, 50/60 Hz battery charger (EC plug standard)	4 lb	\$330.00
<b>4300 Sub Hook with Shackle</b>			
Consult	500 to 10,000 lb, 6.5 ton shackle	-	Consult
Consult	20,000 to 30,000 lb, 17 ton shackle	-	Consult
Consult	50,000 lb, 25 ton shackle	-	Consult
Consult	70,000 lb, 40 ton shackle	-	Consult
Consult	100,000 lb, 55 ton shackle	-	Consult
<b>4300 Oversize Lifting Eye/Shackle</b>			
Consult	500 to 10,000 lb capacity	-	Consult
Consult	20,000 to 30,000 lb capacity, adapter with 25 ton shackle	-	Consult
Consult	50,000 to 70,000 lb capacity	-	Consult
Consult	100,000 lb capacity	-	Consult

## Standard Features

- Crane scale unit with six-digit, 1.6 in (40 mm), backlight LCD display
- Top lifting eye or shackle, bottom thrust bearing swivel hook
- 12 volt rechargeable battery and universal 115/230 VAC, 50/60 Hz battery charger (NA plug standard)

## Options

(Contact MSI for application consultation)

- D-cell battery option, provides up to 2,000 hours of operation
- Substitute bottom swivel hook with shackle
- Oversized top-lifting eye or shackle
- Oversized bottom hook
- Universal direct power supply; 85 to 265 VAC, 47 to 440 Hz /130 to 300 VDC
- Low headroom top adapter
- Audible setpoint alarm
- Custom top and bottom interfaces
- Crane scale cart

## Specifications

### Accuracy:

± (0.1% +1 d) of applied load

### Resolution:

3,000 to 5,000 d standard  
(Up to 10,000 d available)

### Enclosure:

NEMA Type 4, IP66, marine grade 356 alloy anodized cast aluminum

### Top Lifting Eye, Shackle & Hook:

Crosby® or equal with 360° thrust-bearing swivel hook

### Design Overload:

200% Safe / 500% Ultimate (except where noted)

### Functions:

Power, zero, net/gross, tare and programmable test/user

### Display:

6 digit, 1.6 in (40 mm) LCD (upper) 8 digit, 0.8 in (20 mm) LCD (lower) with adjustable display contrast

### Displayable Units:

Pounds, kilograms, tons, and metric tons selectable

### Power:

12 V rechargeable battery. 115/230 VAC battery charger included

### Operating Time:

300 hours with typical use

### Operating Temperature:

5° F to 122° F (-15 °C to 50 °C)  
Legal for Trade: 14 °F to 104 °F (-10 °C to 40 °C)

### Filtering:

OFF, LO, Medium and HI selectable

### Warranty:

One-year limited

### Approvals:

NTEP CC 92-176: 5,000 lb (2,500 kg)  
Measurement Canada AM-4984



Optional crane scale cart

OVERHEAD WEIGHING

# MSI-7300 Dyna-Link 2

Digital Tension Dynamometer



Shown with optional shackles

## Part Number/Price

Part #	Description	Resolution	Est. Weight	Price
139162	1,000 lb (500 kg) F/A	0.5 lb (0.2 kg)	8 lb	\$1,610.00
139163	2,500 lb (1,250 kg) F/A	1 lb (0.5 kg)	9 lb	\$1,610.00
139164	5,000 lb (2,500 kg) F/A	2 lb (1.0 kg)	9 lb	\$1,610.00
139165	10,000 lb (5,000 kg) F/A	5 lb (2.0 kg)	11 lb	\$1,730.00
139166	25,000 lb (12,500 kg) F/A	10 lb (5 kg)	19 lb	\$2,310.00
139167	50,000 lb (25,000 kg) F/A	20 lb (10 kg)	29 lb	\$3,000.00
139168*	100,000 lb (50,000 kg) F/A	50 lb (20 kg)	65 lb	\$3,910.00
<b>Optional Configurations (for connectivity to MSI-8000 RF Remote Display) F/A</b>				
139441	1,000 lb (500 kg) RF module	0.5 lb (0.2 kg)	8 lb	\$1,810.00
139442	2,500 lb (1,250 kg) RF module	1 lb (0.5 kg)	9 lb	\$1,810.00
139443	5,000 lb (2,500 kg) RF module	2 lb (1 kg)	9 lb	\$1,810.00
139444	10,000 lb (5,000 kg) RF module	5 lb (2 kg)	11 lb	\$1,930.00
139445	25,000 lb (12,500 kg) RF module	10 lb (5 kg)	19 lb	\$2,500.00
139446	50,000 lb (25,000 kg) RF module	20 lb (10 kg)	29 lb	\$3,190.00
139447*	100,000 lb (50,000 kg) RF module	50 lb (20 kg)	65 lb	\$4,110.00
159168*	120,000 lb (60,000 kg) RF module includes MSI-8000	50 lb (20 kg)	57 lb	Consult
159169*	180,000 lb (90,000 kg) RF module includes MSI-8000	100 lb (50 kg)	74 lb	Consult
159170*	260,000 lb (130,000 kg) RF module includes MSI-8000	100 lb (50 kg)	100 lb	Consult
159171*	380,000 lb (190,000 kg) RF module includes MSI-8000	200 lb (100 kg)	169 lb	Consult
159172**	550,000 lb (275,000 kg) RF module includes MSI-8000	200 lb (100 kg)	336 lb	Consult
<b>MSI-7300 Dyna-Link 2 Wi-Fi</b>				
176813	1,000 lb (500 kg) F/A with Wi-Fi	0.5 lb (0.2 kg)	8 lb	\$1,750.00
176814	2,500 lb (1,250 kg) F/A with Wi-Fi	1 lb (0.5 kg)	9 lb	\$1,840.00
176815	5,000 lb (2,500 kg) F/A with Wi-Fi	2 lb (1.0 kg)	9 lb	\$1,840.00
176816	10,000 lb (5,000 kg) F/A with Wi-Fi	5 lb (2.0 kg)	11 lb	\$1,970.00
176817	25,000 lb (12,500 kg) F/A with Wi-Fi	10 lb (5 kg)	19 lb	\$2,550.00
176818	50,000 lb (25,000 kg) F/A with Wi-Fi	20 lb (10 kg)	29 lb	\$3,340.00
176819	100,000 lb (50,000 kg) F/A with Wi-Fi	50 lb (20 kg)	65 lb	\$4,200.00
176827	120,000 lb (60,000 kg) F/A with Wi-Fi	50 lb (20 kg)	57 lb	Consult
176828	180,000 lb (90,000 kg) F/A with Wi-Fi	100 lb (50 kg)	74 lb	Consult
176829	260,000 lb (130,000 kg) F/A with Wi-Fi	100 lb (50 kg)	100 lb	Consult
176830	380,000 lb (190,000 kg) F/A with Wi-Fi	200 lb (100 kg)	169 lb	Consult
176831	550,000 lb (275,000 kg) F/A with Wi-Fi	200 lb (100 kg)	336 lb	Consult

\* 500% Ultimate overload

\*\* 440% Ultimate overload

## Standard Features

- Tension dynamometer with 6-digit, 1.00 in (25 mm) LCD display
- Two C alkaline batteries for capacities up to 10,000 lb (5,000 kg)
- Two D alkaline batteries for capacities 25,000 lb (12,500 kg) and above

## Options

(Contact MSI for application consultation)

- Crosby® top and bottom shackles
- Portable transport case
- Serial output cable
- Rugged remote control (control for On/Off, Zero, Tare and other functions)
- RF modem install for connectivity to MSI-8000, MSI-8000HD RF, MSI-8004HD RF remote display and TranSend. Typically 100 to 300 ft, line of sight, for longer range consult factory
- Heavy capacity configurations (60 to 275 Ton)
- Audible alarm
- Wi-Fi communication is available for specialty applications

## Specifications

### Accuracy:

- 0.1% FS of rated capacity (up to 50 ton)
- 0.5% FS of rated capacity (50 ton and above)

### Enclosure:

- NEMA Type 4, IP65, anodized corrosion-resistant finish

### Material:

- 2024 aircraft grade aluminum
- Capacities above 100 K have zinc plated enclosures and 4340 load cell bodies

### Design Overload:

- 200% Safe/700% Ultimate\* (except where noted)

### Functions:

- On/Off, Zero, Hi-Speed Peak Hold, Setpoints, Total, Tare, Auto-Off, Motion Filter

### Display:

- 6 digit, 1.00 in (25 mm) LCD

### Displayable Units:

- Pounds, kilograms, kilonewtons, tons, metric tons

### LED Annunciators:

- Function 1, Function 2, Setpoint 1, Setpoint 2

### LCD Annunciators:

- Net, Center of Zero, Stable, Battery Test, Peak Hold, Total

### Power:

- Two each C alkaline batteries for capacities up to 10,000 lb two each D alkaline batteries for capacities 25,000 to 100,000 lb

### Operating Time:

- From 150 to 300 hours in typical use depending on unit capacity and battery configuration. Approximately 25 to 30 hours with optional RF modem link installed.

### Operating Temperature:

- -4 °F to 140 °F (-20 °C to 60 °C)

### Calibration:

- Digital

### Filtering:

- OFF, LO, HI selectable

### Data Output:

- Serial RS-232

### Warranty:

- Two-year limited

OVERHEAD  
WEIGHING

# MSI-7300 Dyna-Link 2

Digital Tension Dynamometer

## Options/Accessories

Part #	Description	Est. Weight	Price
151357	Shackle anchor, bolt type 3.25 ton for 500 lb-5,000 lb unit	3 lb/pair	Consult
151355	Shackle anchor, bolt type 6.5 ton for 10,000 lb unit	6 lb/pair	Consult
141992	Shackle anchor, bolt type 17 ton for 25,000 lb unit	39 lb/pair	Consult
151356	Shackle anchor, bolt type 25 ton for 50,000 lb unit	63 lb/pair	Consult
146336	Shackle anchor, bolt type 55 ton for 100,000 lb unit	103 lb	Consult
151359	Shackle anchor, bolt type 85 ton for 180,000 lb unit	206 lb/pair	Consult
151360	Shackle anchor, bolt type 120 ton for 260,000 lb unit	225 lb/pair	Consult
151361	Shackle anchor, bolt type 175 ton for 380,000 lb unit	665 lb/pair	Consult
151358	Shackle anchor, bolt type 250 ton for 550,000 lb unit	1,300 lb/pair	Consult
139381	MSI-8000 RF remote display (requires MSI-7300 equipped with optional RF modem)	5 lb	\$1,320.00
153591	MSI-8000HD RF remote display, A/C powered with tilt stand (requires MSI-7300 equipped with optional RF modem)	5 lb	\$1,440.00
165313	Heavy duty pelican transport case with precision cut. Heavy duty foam for units up to 10,000 lb capacity	10 lb	\$365.00
145076	Transport crate for 25,000 lb and 50,000 lb capacity unit	35 lb	\$440.00
145073	Transport crate for 100,000 lb capacity unit	42 lb	Consult
139470	RS-232 serial cable for MSI-7300	1 lb	\$155.00
178004	LaserLight2, 4 in (101 mm) six-digit RF scoreboard (requires MSI-7300 equipped with optional RF modem)	21 lb	\$2,370.00
178006	LaserLight2, 6 in (152 mm) six-digit RF scoreboard (requires MSI-7300 equipped with optional RF modem)	37 lb	\$2,810.00
149549	Universal 115/ 230 VAC 50/60 Hz (NA plug standard) battery charger for MSI-8000 remote display	3 lb	\$155.00
182223	12V car charger adapter for MSI-8000	1 lb	\$135.00
173014	Rugged remote control (requires MSI-7300 equipped with optional RF modem)	-	\$330.00
150964	RS-232 13 ft (4 m) serial cable for MSI-8000	1 lb	\$190.00
139438	Audible setpoint	-	\$420.00
149550	Battery charger for MSI-8000 EC plug	-	\$150.00

OVERHEAD  
WEIGHING

# MSI Dyna-Clamp

Tension Meter



## Approvals



## Part Number/Price

Part #	Description	Tension	Price
189581	MSI Dyna-Clamp Tension Meter	12,500 lbf (5,670 kgf / 55.60 kN)	\$4,860.00

## Options/Accessories

Part #	Description	Price
198418	Heavy-duty carrying case	\$610.00

## Dimensions

	A	B	C	D
A	25.70 in (652.80 mm)		C	13.75 in-15.50 in (349.25 mm-393.70 mm)
B	7.30 in (185.50 mm)		D	3.70 in (94 mm)

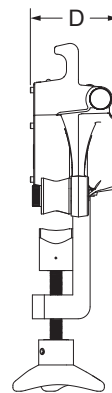
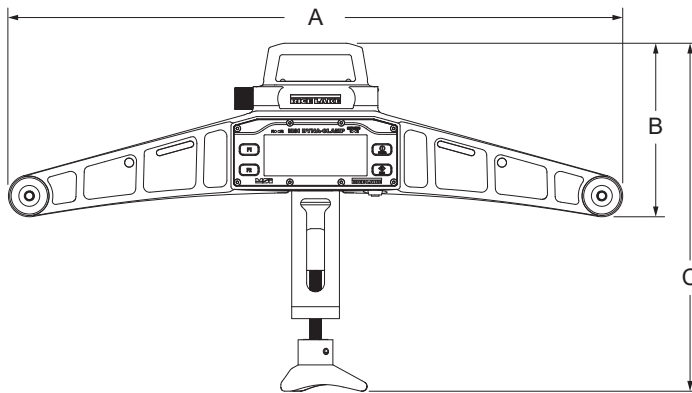

## Standard Features

- Dual line LCD display
- Two user-programmable function keys
- IP65 anodized aluminum frame
- RS-232 port
- Up to 8 factory calibrations included at no additional cost

## Options

(Contact MSI for application consultation)

- Heavy-duty carrying case

## Specifications

### Power:

Battery operated two AA Cell 1.5 V alkaline batteries (can be replaced with rechargeable NiMH cells)

### Max Tension:

12,500 lbf (5,670 kgf / 55.60 kN)

### Operating Time:

Alkaline AA Cells 24 hours

### Wire Rope:

Diameter 3/16 in (5 mm) to 1 in (25 mm)

### Accuracy:

Rated Accuracy  $\pm 3\%$  of capacity

### Units:

lbf, kgf, kN

### Resolution:

Standard: 2,500 divisions

### Two-Line LCD Display:

Primary display (bottom) six, 0.7 in (18 mm)

numeric digits

Secondary display (top) eight, 0.5 in (13 mm)

numeric digits

### Function Keys:

Two programmable keys (user-defined) – F1, F2

(test, unit, print, scroll, actfun)

Two permanent keys – power, zero

### Setpoints:

Two dedicated setpoints for minimum and maximum allowable wire rope tension (LEDs for measurements outside of allowable range)

(LEDs for measurements outside of allowable range)

### Auto-Off Mode:

Prolongs battery life by turning power OFF

after 15, 30, 45 or 60 minutes of no activity

(user determined)

### Enclosure:

IP65 powder-coated aluminum frame

### Calibration:

Up to eight factory programmed wire rope calibrations

### Operating Temperature:

-4 °F to 122 °F (-20 °C to 50 °C)

### Operator Use:

Outdoor

### Storage:

Indoor

### Warranty:

Two-year limited

### Approvals:

CE Marked

UKCA

OVERHEAD  
WEIGHING



# MSI Clamp-On

Load Cell



## Standard Features

- ETD 150 construction
- Accommodates up to 3/4 in wire rope size
- IP68
- Larger diameter clamp-on available - call for pricing

## Options

(Contact MSI for application consultation)

- Custom sizes available on request
- Pair with an SCT transmitter for basic safety functions

## Specifications

**System Accuracy of Calibrated Capacity:**  
3 to 5%

**Material:**  
4340 steel, zinc plated

**Output Resistance:**  
350 ohm

**IP Rating:**  
IP68

**Cable Color Code:**  
Red +Excitation  
Black -Excitation  
Green +Signal  
White -Signal

**Cable Length:**  
20 ft integral cable with blunt end termination

## Part Number/Price

Part #	Description	Price
179080	Load Cell Assembly Clamp-On for 3/8 to 1/2 in wire rope	\$710.00
179082	Load Cell Assembly Clamp-On for 9/16 to 3/4 in wire rope	\$840.00
188816	Kit with SCT-2200 for 3/8 to 1/2 in wire rope	\$1,330.00
188817	Kit with SCT-2200 for 9/16 to 3/4 in wire rope	\$1,470.00

Larger diameter clamp ons available - call for pricing

## Dimensions

Cable Range	P/N	A	B	C
3/8 - 1/2	179080	Cable + 1.70	6.00	2.00
9/16-3/4	179082	Cable + 1.67	6.00	2.00

\*8mm cable can be used with PN 179080

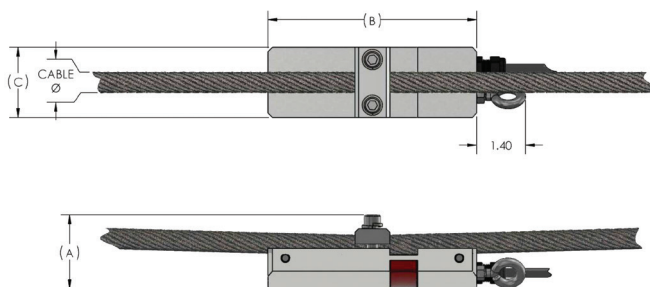

Optional SCT-2200 transmitter

OVERHEAD WEIGHING

Custom  
Outputs Available



## Standard Features

- Internally gauged load pin
- Idler sheave or dead end pin preferred location
- Minimum 5:1 safety factor
- 17-4 stainless steel construction
- $\pm 1\%$  to 3% accuracy of hoist capacity
- -40 °F to 140 °F standard operating temperature (other temperature compensated ranges available)

(Contact MSI for application consultation)

A key component for MSI's integrated overhead weighing solutions is the Load Pin Sensor. Typically designed and manufactured specifically to each integrated solution, the MSI load pin is strictly industrial grade. Each load pin design is precision machined from 17-4 stainless steel for safety, strength and corrosion resistance.

Each strain gauge location is precisely calculated and correctly placed in the optimum concentrated stress area of each installation. This MSI applied engineering process ensures the most efficient and accurate performance for each specific installation.

MSI load pin designs apply only internally mounted strain gauges for complete protection from the outside environment.

To receive a quotation for a load pin sensor to meet your application requirements, complete the load pin questionnaire on page 702 or online at [www.ricelake.com/questionnaires](http://www.ricelake.com/questionnaires) or contact an MSI overhead weighing specialist for further application assistance.



# MSI Load Pin Questionnaire

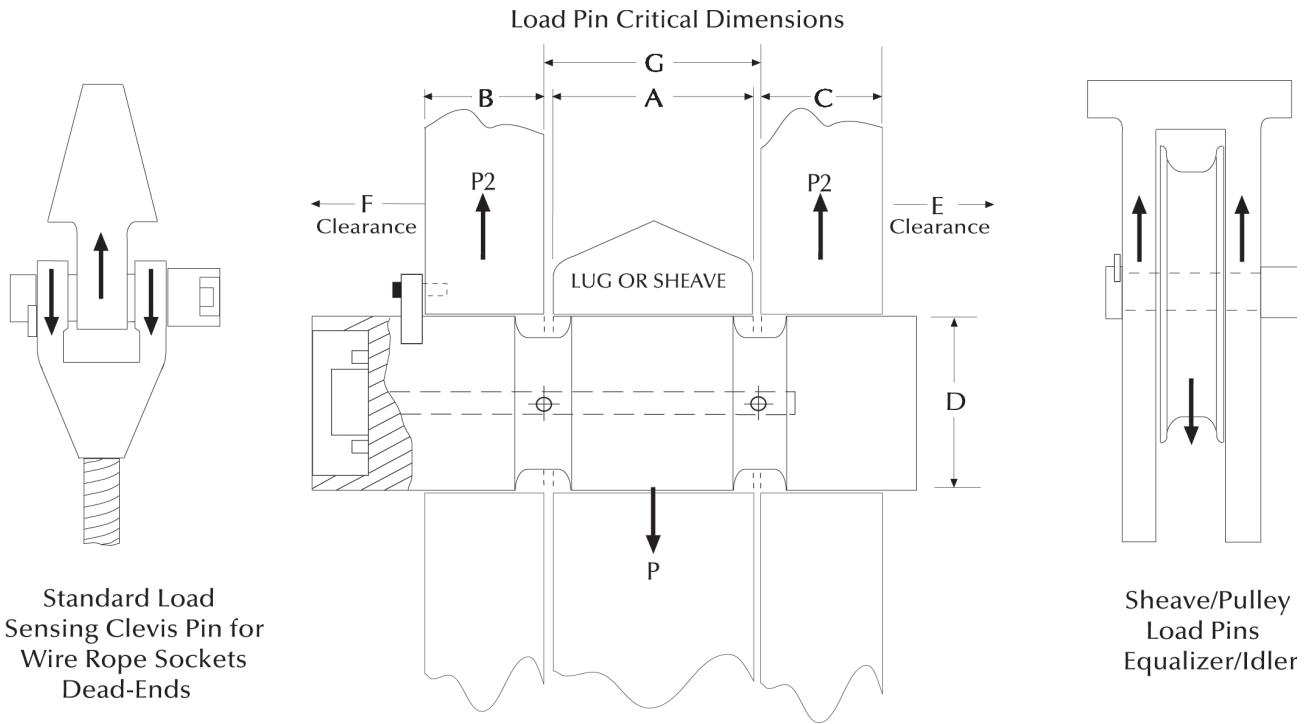

**OVERHEAD WEIGHING**

Load Pin Data	
A=Width _____	Inch
B=Width _____	Inch
C=Width _____	Inch
D=Pin Diameter _____	Inch
E=Clearance _____	Inch
F=Clearance _____	Inch
G=Width _____	Inch
Lube Port <input type="checkbox"/> No <input type="checkbox"/> Yes _____	# of exits
Hoist Capacity _____	Tons
Parts of Wire Rope _____	
Sensor Capacity _____	Tons
Factor of Safety <input type="checkbox"/> 3:1 <input type="checkbox"/> 5:1 <input type="checkbox"/> 7:1 <input type="checkbox"/> 10:1	
Application _____	
Accuracy Requirement _____	
Temperature Requirement _____	
Required Output _____	
Material Testing Requirement _____	
Load Vector Orientation/Alignment <input type="checkbox"/> ← <input type="checkbox"/> → <input type="checkbox"/> ↘ <input type="checkbox"/> ↗	
Name _____	
Company _____	
Phone _____	
Note: Minimum clearance between "A" and "G" = 0.0625 inch.	

Cable Connections	
End-Mounted Cable	
End-Mounted Connector (standard)	
Side-Mounted Cable	
Side-Mounted Connector	
Recessed Connector	
Sensor's Cable Length _____	Feet
Comments _____	



230 W. Coleman St. • Rice Lake, WI 54868 • USA  
 TEL: 800-874-4320 • FAX: 206-244-8470 • [www.ricelake.com/msi](http://www.ricelake.com/msi)

An ISO 9001 registered company © 2019 Rice Lake Weighing Systems PN 154086 10/19  
 Specifications subject to change without notice.

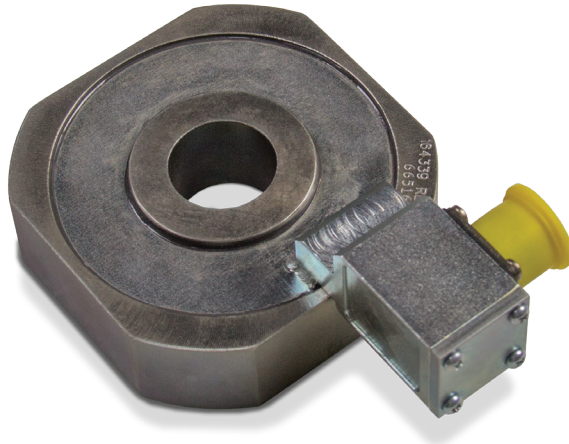

### Standard Features

- Designed to be placed above the trunnion of a load block, this integrated low-profile load cell eliminates headroom loss
- Off-axis compensation

(Contact MSI for application consultation)

### Specifications

#### Accuracy (Static Load):

0.5 to 1% system accuracy of rated capacity

#### Material:

4340 alloy steel, zinc plated

#### IP Rating:

IP67

#### Resistance:

700 ohms

### Part Number/Price

Part #	Description	Est. Weight	Price
160651	10,000 lb/5,000 kg capacity	5 lb	Consult
163595	20,000 lb/10,000 kg capacity	10 lb	Consult
163596	40,000 lb/20,000 kg capacity	20 lb	Consult
163829	60,000 lb/30,000 kg capacity	30 lb	Consult
163597	80,000 lb/40,000 kg capacity	34 lb	Consult
163598	100,000 lb/50,000 kg capacity	38 lb	Consult
159550	120,000 lb/60,000 kg capacity	60 lb	Consult
163599	160,000 lb/80,000 kg capacity	105 lb	Consult
163600	200,000 lb/100,000 kg capacity	215 lb	Consult

### Options/Accessories

Part #	Description	Price
165978	Load cell interface cable to TranSend™, 6.5 ft	\$315.00
165979	Load cell interface cable to TranSend, 10 ft	\$340.00
165980	Load cell interface cable to TranSend, 16 ft	\$360.00
165989	Load cell interface cable to TranSend, 20 ft	\$390.00
165990	Load cell interface cable to TranSend, 25 ft	\$420.00
165991	Load cell interface cable to TranSend, 32 ft	\$485.00
134498	Load cell interface cable to CellScale™, 5 ft	\$350.00
134495	Load cell interface cable to CellScale, 10 ft	\$380.00
134500	Load cell interface cable to CellScale, 15 ft	\$400.00
134499	Load cell interface cable to CellScale, 20 ft	\$430.00
134501	Load cell interface cable to CellScale, 25 ft	\$460.00

### Dimensions

Part #	Capacity	A	B	C (+0.005- 0.000)	D	E	F	G	H	Required Hook Shank Diameter (+0.000,-0.005)
160651	10,000 lb	3.500	1.350	1.005	2.450	1.880	4.905	1.500	1.000	1.000
163595	20,000 lb	6.000	2.500	1.505	3.500	2.443	7.405	1.750	1.250	1.500
163596	40,000 lb	7.500	3.150	2.005	5.000	2.580	8.905	2.000	1.375	2.000
163829	60,000 lb	8.000	3.190	2.505	5.250	2.695	9.405	2.188	1.500	2.500
163597	80,000 lb	8.500	3.650	3.505	5.750	2.680	9.905	2.313	1.500	3.500
163598	100,000 lb	9.125	3.873	4.005	7.000	2.382	10.530	2.668	1.875	4.000
159550	120,000 lb	9.125	3.873	4.005	7.000	2.382	10.530	2.813	2.000	4.000
163599	160,000 lb	16.000	7.030	6.005	14.500	2.955	17.405	4.625	2.500	6.000
163600	200,000 lb	16.000	7.030	6.005	14.500	2.955	17.405	5.125	3.000	6.000

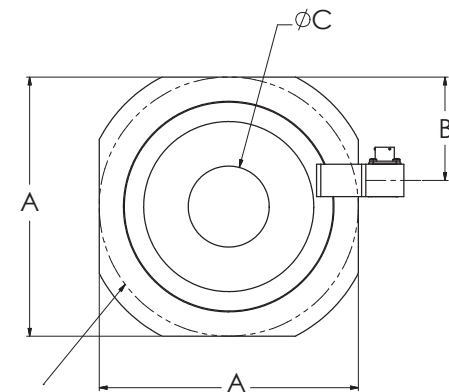
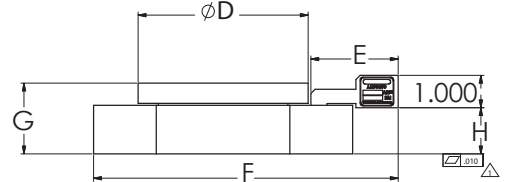

SHOWN AS REFERENCE  
FOR ROUND LOAD CELLS

OVERHEAD  
WEIGHING

# MSI Tension Link

Load Cell



## Standard Features

- 4340 steel construction
- Mil spec connector
- 7:1 safety factor

## Options

(Contact MSI for application consultation)

- Crosby® top and bottom shackles

## Specifications

### Input Resistance:

1,500 ohm

### Output Resistance:

2,000 ohm

### Full Scale Output:

0.8 mV/V

### Connector Pin Out:

A: EX+

B: Sig +

C: Sig -

D: EX-

### Accuracy:

0.1% sensor accuracy

### Material:

4340 steel

## Part Number/Price

Part #	Description	Price
181907	2K 7200 Style Load Cell Only	Consult
181908	5K 7200 Style Load Cell Only	Consult
181909	10K 7200 Style Load Cell Only	Consult
178093	25K 7200 Style Load Cell Only	Consult
178094	50K 7200 Style Load Cell Only	Consult
181910	100K 7200 Style Load Cell Only	Consult
134505	Mating Cable Assembly, 10 ft	\$175.00

Contact factory for higher capacities

## Dimensions

Capacity (lbs)	P/N	Load Cell Material	(A) Headroom Loss	(B) C-C Length	(C) Lug Thk	(D) Body Thk	(E) Body Width	(F) Body Length	Lug Hole	Crosby Shackle
2,000	181907	Aluminum	13.50 in	8.00 in	0.99 in	2.13 in	4.50 in	9.75 in	0.78 in	3-1/4 T 151357
5,000	181908	Aluminum	13.50 in	8.00 in	0.99 in	2.13 in	4.50 in	9.75 in	0.78 in	3-1/7 T 151357
10,000	181909	Aluminum	16.13 in	8.50 in	1.35 in	2.13 in	5.37 in	10.75 in	1.05 in	6-1/2 T 151355
25,000	178093	Steel	22.39 in	9.26 in	2.24 in	2.24 in	4.80 in	12.76 in	1.67 in	17 T 141992
50,000	178094	Steel	25.74 in	9.76 in	2.74 in	2.81 in	5.43 in	13.76 in	2.05 in	25 T 151356
100,000	181910	Steel	28.49 in	10.74 in	3.09 in	3.09 in	6.86 in	15.74 in	2.30 in	55 T 146336

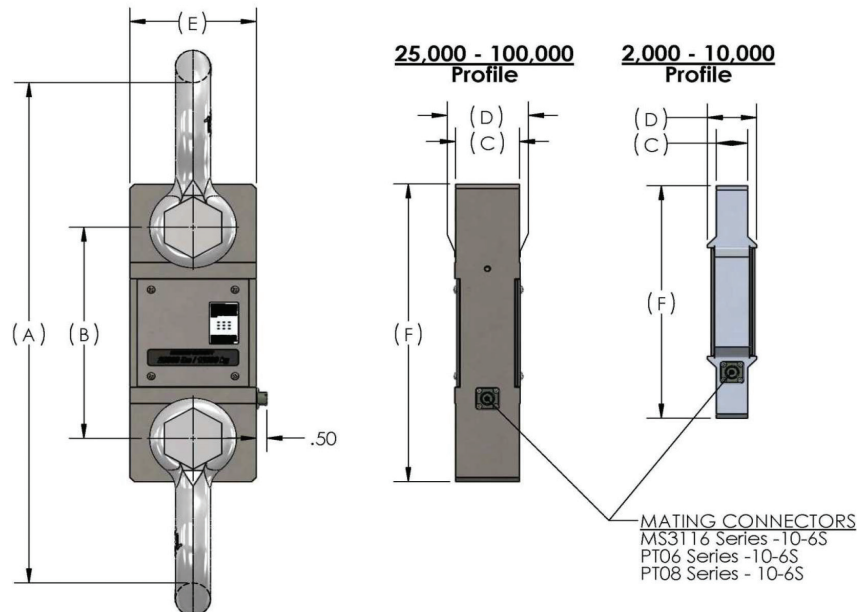

OVERHEAD WEIGHING

# Shackle Dimensions

## Part Number/Price

Part #	W.L.L. Tons	Size	A	B	C	D	E	F	H	L	N	P	Weight	Price
151357	3 1/4	0.63 in	1.06 in	.75 in	2.38 in	0.63 in	1.69 in	1.56 in	4.22 in	2.94 in	0.69 in	N/A	1.58 lb	Consult
151355	6 1/2	0.88 in	1.44 in	1.00 in	3.31 in	0.88 in	2.28 in	2.13 in	5.75 in	4.03 in	0.97 in	5.00 in	3.95 lb	Consult
141992	17	1.50 in	2.38 in	1.63 in	5.75 in	1.50 in	3.88 in	3.63 in	9.88 in	6.88 in	1.62 in	8.25 in	19.50 lb	Consult
151356	25	1.75 in	2.88 in	2.00 in	7.00 in	1.75 in	5.00 in	4.32 in	11.88 in	8.50 in	2.12 in	9.59 in	31.30 lb	Consult
146334	30	1.50 in	2.38 in	1.63 in	5.75 in	1.50 in	3.88 in	3.63 in	9.88 in	6.88 in	1.62 in	8.25 in	20.80 lb	Consult
146335	40	1.75 in	2.88 in	2.00 in	7.00 in	1.75 in	5.00 in	4.32 in	11.88 in	8.50 in	2.12 in	9.59 in	33.91 lb	Consult
146336	55	2.00 in	3.25 in	2.25 in	7.75 in	2.00 in	5.75 in	5.00 in	13.38 in	9.75 in	2.00 in	11.00 in	51.75 lb	Consult
151359	85	2.5 in	4.12 in	2.75 in	10.50 in	2.72 in	7.25 in	5.69 in	17.84 in	12.87 in	3.12 in	13.58 in	96.00 lb	Consult
151360	120	3.00 in	5.00 in	3.25 in	13.00 in	3.00 in	7.88 in	6.50 in	21.50 in	14.50 in	3.63 in	16.50 in	178.00 lb	Consult
83455	120	3 in	5.00 in	3.25 in	13.00 in	3.11 in	7.88 in	6.50 in	21.50 in	14.36 in	3.63 in	15.13 in	178.00 lb	Consult
151361	175	4.00 in	5.50 in	4.25 in	14.50 in	4.00 in	10.00 in	9.00 in	25.69 in	18.38 in	4.56 in	19.75 in	338.00 lb	Consult
151358	250	4 in	8.50 in	5.00 in	20.00 in	4.50 in	13.00 in	12.00 in	35.00 in	24.50 in	6.50 in	22.68 in	600.00 lb	Consult
<b>Oversized Shackles</b>														
148497	40	1.75 in	2.88 in	2.00 in	10.00 in	2.25 in	6.00 in	4.32 in	15.35 in	10.50 in	2.25 in	9.00 in	45.00 lb	Consult
148393	40	2.25 in	2.88 in	2.00 in	12.50 in	2.25 in	8.00 in	4.32 in	17.85 in	12.50 in	2.25 in	10.00 in	90.00 lb	Consult
148394	50	2.00 in	3.25 in	2.25 in	12.25 in	2.50 in	8.00 in	5.00 in	18.50 in	13.00 in	2.50 in	11.00 in	72.00 lb	Consult
<b>Shims</b>														
146534	(For use with 50,000 ton/70,000 ton systems)													Consult

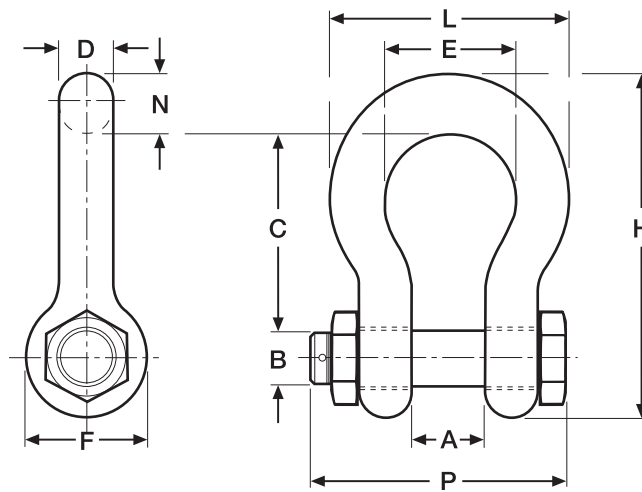

OVERHEAD WEIGHING

# MSI-8000

RF Remote Display



## Part Number/Price

Part #	Description	Est. Weight	Price
139381	MSI-8000 RF remote display (requires ScaleCore™ equipped MSI-7300, MSI-4260, MSI-3460 and TranSend receivers)	5 lb	\$1,320.00

## Options/Accessories

Part #	Description	Est. Weight	Price
149549	Universal 115/230 VAC 50/60 Hz (NA plug standard) battery charger for MSI-8000 RF remote display	3 lb	\$155.00
149550	Universal 115/230 VAC 50/60 Hz (EC plug standard) battery charger for MSI 8000 RF remote display	1 lb	\$150.00
150964	DB9 female serial interface cable for MSI-8000 RF remote display	1 lb	\$190.00
151095	Audible alarm	—	\$300.00
182223	12V car charger adapter for MSI-8000	1 lb	\$135.00

## Dimensions

	A	B	C	D
A	8.00 in (203 mm)		3.85 in (98 mm)	
B		3.85 in (98 mm)		1.37 in (35 mm)

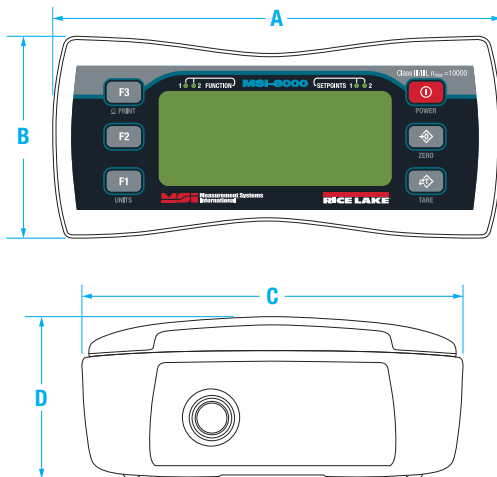

## Standard Features

- Handheld RF remote display with six-digit 1.0 in (26.4 mm) LCD screen
- Membrane keypad for remote control functionality
- User-definable function keys for added versatility
- Universal 115/230 VAC, 50/60 Hz battery charger (NA plug standard)
- Communicates with RF MSI-3460 Challenger 3, MSI-4260 Port-A-Weigh, MSI-7300 Dyna-Link 2, MSI-7000 and MSI-7001 TranSend™

(Contact MSI for application consultation)

## Specifications

### Enclosure:

NEMA Type 4, IP65

### Weight:

0.98 lb (445 g)

### Keypad:

On/Off, Zero (100%), Tare, Print, and two user-defined keys for the following functions: peak hold, high resolution, total, view total, net/gross, units switching

### Display:

Six-digit 1.0 in (26.4 mm) LCD

### Units Displayed:

Pounds, kilograms, tons, metric tons, kilonewtons

### Annunciators:

Stable, COZ, low battery, peak, net, kg, kN, lb, M, ton, setpoint, function LEDs

### Power:

Integral lithium ion battery  
Universal 115/230 VAC, 50/60 Hz battery charger (NA plug included)

### Operating Time:

Up to 24 hours of continuous use (15 minute auto-shutoff with non-use)

### Operating Temperature:

-4 °F to 140 °F (-20 °C to 60 °C)

### RF Radio Link:

2.4 GHz 802.15.4  
Communicates with RF 3460, 4260, 7300, 7000 & 7001

### RF Effective Range:

Typically 100 to 300 ft, line of sight; for longer range consult factory

### Connector:

Four-pin Turck connector for charging and RS-232 communication

### Warranty:

One-year limited

OVERHEAD WEIGHING

# MSI-8000HD

Indicator/Remote Display



## Approvals



## Standard Features

- Indicator or RF remote display with six-digit 1.0 in (26 mm) LCD screen
- IP68 milled aluminum enclosure
- Membrane keypad for remote-control functionality
- User-definable function keys for added versatility
- Compatible with all ScaleCore™-based products including: MSI-7300 Dyna-Link 2, MSI-3460 Challenger 3, MSI-4260 Port-A-Weigh, MSI-7000 and MSI-7001 TranSend™, MSI-9600HT and MSI-6360
- Swivel tilt stand

Dimensions	
A	5.09 in (129 mm)
B	8.98 in (228 mm)
C	1.35 in (34 mm)
D	1.63 in (41 mm)

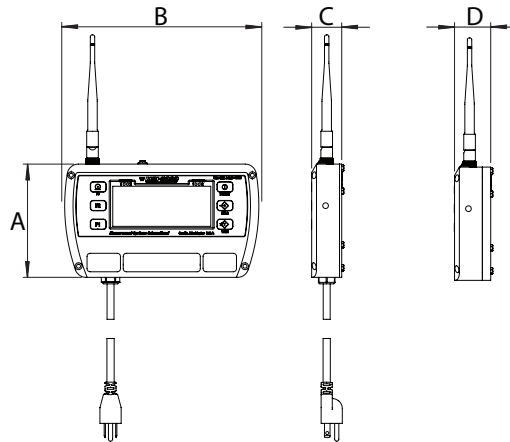

Dimensions With Tilt Stand	
A	11.06 in (281 mm)
B	9.13 in (232 mm)
C	9.50 in (241 mm)
D	8.02 in (204 mm)
E	6.16 in (156 mm)
F	3.25 in (83 mm)

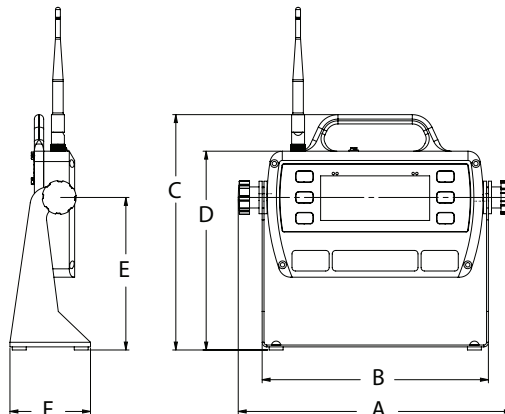

## Options

(Contact MSI for application consultation)

- Up to 8 configurable relay outputs
- Wi-Fi communications
- Bluetooth® communications
- 802.15.4 Serial RF
- FHSS
- Wired Ethernet

## Specifications

### Power:

90-267 VAC, 9-36 VDC, 18-72 VDC, 120-300 VDC  
Optional battery power module available

### Enclosure:

NEMA Type 4, IP68 milled anodized aluminum  
with O-ring gaskets

### RF Remote Channels:

Up to four remote sensors, monitored individually,  
in pairs or sum all (non-A/D version only)

### Service Counters:

A/D version only

### A/D Inputs:

Two independent or summing load cell inputs

### Excitation:

4.8V current limited and over-voltage protected

### Filtering:

Off, Low, Hi-1, Hi-2

### RF Radio Link:

2.4 GHz 802.15.4

Compatible with all ScaleCore™-based  
products including:

MSI-7300 Dyna-Link 2, MSI-3460 Challenger 3,  
MSI-4260 Port-A-Weigh, MSI-7000 and MSI-7001

### RF Effective Range:

Typically 100 to 300 ft, line of sight;  
for longer range consult factory

### Communication Ports:

Dual RS-232 communication ports

### Optional Communications:

Wi-Fi

Serial RF (Single Sequence or FHSS)

### Annunciators:

Stable, COZ, peak, kg, kN, lb, M, ton, setpoint,  
function LEDs

Channels: 1, 2, 3, 4, TTL

### Units Displayed:

Pounds, kilograms, tons, metric tons, kilonewtons

### Display:

Six-digit 1.0 in (26.4 mm) LCD

### Keys/Buttons:

On/Off, Zero (100%), Tare, Print, and Two user-  
defined keys for the following functions: peak hold,  
high resolution, total, view total, net/gross, units  
switching

### Temperature Range:

-4 °F to 140 °F (-20 °C to 60 °C)

Legal for Trade: 14 °F to 104 °F (-10° °C to 40 °C)

### Warranty:

One-year limited

### Approvals:

NTEP CC15-110 (-10 °C to 40 °C)

OVERHEAD  
WEIGHING



# MSI-8000HD

Indicator/Remote Display

## Part Number/Price

Part #	Description	Est. Weight	Price
153591	ScaleCore RF/Remote Display/85-265 VAC	5 lb (2.5 kg)	\$1,440.00
154853	ScaleCore RF/Remote Display/Internal Battery	5 lb (2.5 kg)	\$1,560.00
160476	ScaleCore RF/Remote Display/7-36 VDC	5 lb (2.5 kg)	\$1,390.00
159377	ScaleCore RF/Remote Display/18-72 VDC	5 lb (2.5 kg)	\$1,420.00
159376	ScaleCore RF/Remote Display/9-36 VDC	5 lb (2.5 kg)	\$1,420.00
158427	Meter/2 A/D Inputs/85-265 VAC (non RF)	5 lb (2.5 kg)	\$1,750.00
158428	Meter/2 A/D Inputs/Internal Battery (non RF)	5 lb (2.5 kg)	\$1,860.00
160478	Meter/2 A/D Inputs/7-36 VDC (non RF)	5 lb (2.5 kg)	\$1,560.00
159381	Meter/2 A/D Inputs/18-72 VDC (non RF)	5 lb (2.5 kg)	\$1,600.00
159380	Meter/2 A/D Inputs/9-36 VDC (non RF)	5 lb (2.5 kg)	\$1,600.00
158425	RF Meter/2 A/D Inputs/85-265 VAC	5 lb (2.5 kg)	\$1,770.00
158426	RF Meter/2 A/D Inputs/Internal Battery	5 lb (2.5 kg)	\$1,930.00
160477	RF Meter/2 A/D Inputs/7-36 VDC	5 lb (2.5 kg)	\$1,770.00
159379	RF Meter/2 A/D Inputs/18-72 VDC	5 lb (2.5 kg)	\$1,780.00
159378	RF Meter/2 A/D Inputs/9-36VDC	5 lb (2.5 kg)	\$1,780.00
176958	Wi-Fi Meter/85/265 VAC	5 lb (2.5 kg)	\$1,470.00
176960	Wi-Fi Meter/Internal Battery	5 lb (2.5 kg)	\$1,600.00
176964	Wi-Fi Meter/7-36 VDC	5 lb (2.5 kg)	\$1,420.00
176966	Wi-Fi Meter/9-36 VDC	5 lb (2.5 kg)	\$1,460.00
176968	Wi-Fi Meter/18-72 VDC	5 lb (2.5 kg)	\$1,460.00

## Options/Accessories

Part #	Description	Price
155173	MSI-8000HD spare tilt stand option kit	\$83.00
155193	MSI-8000HD Ethernet TCP/IP option kit wired	\$410.00
162178	Antenna extension kit, 6 ft	\$465.00
148624	MSI-8000HD serial RS-232 cable	\$135.00
158779	MSI-8000HD two each coil relay option kit, 250 VAC/30 VDC 5A or 100 VDC 0.4A	\$355.00
158780	MSI-8000HD two each solid state relay option kit, 60 Vpk 2.7A	\$355.00
158781	MSI-8000HD two each solid state relay option kit, 200 Vpk 0.9A	\$355.00
149549	Universal 115/230 VAC 50/60 Hz (NA plug standard) battery charger for MSI-8000HD battery powered device	\$155.00
149550	Universal 115/230 VAC 50/60 Hz (international plugs) battery charger for MSI-8000HD battery powered device	\$150.00
171203	Audible alarm kit	\$355.00
176963	Serial print cable (for GoDex printer)	\$155.00
<b>Relays</b>		
172490	Expanded Relay Kit, Four-Channel, 12A 5V, Latching Relays	Consult
172492	Expanded Relay Kit, Four-Channel, 12A 5V, Momentary Relays	Consult
Consult	Expanded Relay Kit, Four-Channel, 0.9A 200Vpk, AC/DC Solid State Relays	Consult
172495	Expanded Relay Kit, Eight-Channel, 12A 5V, Momentary Relays	Consult
172500	Expanded Relays Option Kit, Four-Channel, 3A, 60Vpk Solid State Form C Relays	Consult
172501	Expanded Relays Option Kit, Eight-Channel, 3A 60Vpk, Solid State Form C Relays	Consult
172502	Expanded Relays Option Kit, Eight-Channel, 0.9A 200Vpk, Solid State Form C Relays	Consult
171676	Expanded Relays Option Kit, Eight-Channel, 12A 5V, Latching Relays	Consult

OVERHEAD WEIGHING



# MSI-8004HD

Indicator/RF LED Remote Display



## Approvals



## Part Number/Price

Part #	Description	Price
<b>Indicator</b>		
196904	4CH AC, Red/Green Instant Power-On, 85~264VAC, 47~440 Hz, 120~370 VDC	\$2,240.00
178265	4CH AC, Red/Green 85~264 VAC, 47~440 Hz, 120~370 VDC	\$2,030.00
178269	4CH DC 8-32 V, Red/Green Best for external 12 V SLA Batteries	\$2,060.00
178271	4CH DC 9-36 V Iso, Red/Green Do not use on 12 V Vehicle Systems	\$2,160.00
183481	4CH 5V Red/Green with external rechargeable battery	\$2,040.00
<b>Remote Display</b>		
178281	AC, Red/Green 85~264 VAC, 47~440 Hz, 120~370 VDC	\$1,980.00
178283	DC, 8-32 V, Red/Green Best for external 12 V SLA Battery	\$1,940.00
178285	DC, 9-36 V Iso, Red/Green Do not use on 12 V Vehicle Systems	\$2,020.00
183479	4CH 5V Red/Green with external rechargeable battery	\$1,750.00

## Dimensions

With Tilt Stand			
A	11.10 in (282 mm)	E	9.13 in (232 mm)
B	8.76 in (223 mm)	F	6.16 in (156 mm)
C	8.02 in (204 mm)	G	3.25 in (83 mm)
D	5.09 in (129 mm)	H	1.66 in (42 mm)

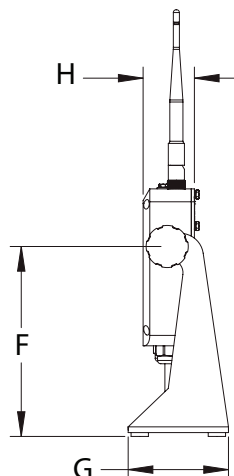
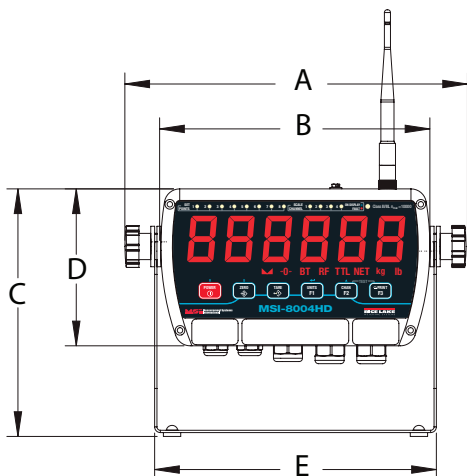

## Standard Features

- IP65 rugged milled aluminum enclosure
- Backlit membrane keypad for user functioning and controls
- Tilt bracket included
- Color changing LED display

## Options

(Contact MSI for application consultation)

- Expanded relay outputs
- Battery pack for mobile operation
- Second radio module for additional network connectivity

## Specifications

### Power:

90 to 267 VAC, 9 to 36 VDC, 18 to 72 VDC, 120 to 300 VDC

### Enclosure:

NEMA Type 4, IP65 milled anodized aluminum

### Functions:

Peak hold, high resolution, total, view total net/gross, units switching

### Units:

Pounds, kilograms, tons, metric tons, kilonewtons

### Channels:

1, 2, 3, 4, TTL

### RF Remote Channels:

Up to 4 remote sensors monitored individually, in pairs or sum all (non-A/D version only) (when used with TranSend)

### Service Counters:

A/D version only

### A/D Inputs:

Four independent or summing load cell inputs

### Excitation Voltage:

4.8 V current limited and over-voltage protected

### Relays:

Two 5 V coil, 250 VAC, 5 A relays

### Filtering:

Off, Low, Hi-1, Hi-2

### RF Radio Link:

2.4 GHz 802.15.4, optional second channel for Serial RF, 802.11 Wi-Fi, cellular connectivity

### RF Effective Range:

Typically 100 to 300 ft, line of sight; for longer range consult factory

### Communication Ports

Two RS-232 hard wired communication ports

### Annunciators:

Stable, COZ, peak, kg, kN, lb, M, ton, setpoint, function LEDs

### Display:

Six-digit, 1.5 in (38 mm) LED display with red/green/orange coloring

### Keys/Buttons:

On/Off, Zero, Tare, Print and two user-defined keys

### Temperature Range:

-4 °F to 140 °F (-20 °C to 60 °C)

### Warranty:

One-year limited

### Approvals:

NTEP CC #17-036 (-5 °C to 40 °C)  
Measurement Canada AM-6068

OVERHEAD  
WEIGHING

# MSI-8004HD

Indicator/RF LED Remote Display

## Options/Accessories

Part #	Description	Price
148624	Serial Cable, RS-232 9000 Serial Cable, DCE	\$135.00
139309	Antenna Kit, Long Range Omni-directional, 9 dBi with 3 m Coax Intended for omni-directional mast mounting (up to 2" Ø). Beam-width. Must be mounted vertically.	\$485.00
139310	Antenna Kit, Corner Reflector, 9 dBi with 3 m coax intended for directional wall or mast mounting (up to 2" Ø). Beam-width: 75° Elevation, 65° Azimuth.	\$480.00
139311	Antenna Kit, Corner Reflector, 12 dBi with 3 m coax intended for directional wall or mast mounting (up to 2" Ø). Beam-width: 50° Elevation, 36° Azimuth.	\$510.00
139312	Antenna Kit, YAGI, 15 dBi with 3 m coax highly directional wall or mast mounting (up to 2" Ø). Beam-width: 30° Elevation, 34° Azimuth.	\$395.00
139313	Antenna Kit, Vehicle Mount, 5 dBi with 5 m coax omni-directional. Mounts in 3/4" Hole.	\$150.00
162178	Antenna extension kit, 6 ft	\$465.00
197013	Antenna extension kit, 20 ft	\$495.00
155173	Spare kit, tilt stand	\$83.00
171203	Audible alarm not compatible with battery versions	\$355.00
22436	Cable, Comm DB9F 9 Pin Fem One end stripped and tinned on other end 6' Pin 2 (Brown) Pin 3 (Red) Pin 5 (Yellow) For use with MSI-8004HD serial ports to connect to: Scoreboard displays, printers, computers & other equipment that supports RS-232.	\$67.00
183437	Battery, 5V Li-ion battery with USB power ports. Output 5 V/3.0A per port (6.0 A max)Rate, 2A per port (4A if both ports are used).	\$225.00
184131	8004 option kit, WiFi with SMA antenna	\$190.00
187424	8004 option kit, 2nd Xbee with TNC antenna	\$200.00
182224	Power Adapter, 12 VDC 5 VDC dual USB car charger plus 3 ft USB cable	\$56.00
<b>Relays</b>		
172500	Expanded relays option kit, four-channel, 3A, 60VPK SSR form C	Consult
172501	Expanded relays option kit, eight-channel, 3A 60VPK, SSR form C	Consult
Consult	Expanded relays option kit, four-channel, 0.9A 200VPK, AC/DC SSR Form C	Consult
172502	Expanded relays option kit, eight-channel, 0.9A 200VPK, SSR form C	Consult
172492	Expanded relays option kit, four-channel, 12A 5V, momentary	Consult
172495	Expanded relays option kit, eight-channel, 12A 5V, momentary	Consult
172490	Expanded relays option kit, four-channel, 12A 5V, latching relays	Consult
171676	Expanded relays option kit, eight-channel, 12A 5V, latching relays	Consult

\* ScaleConnect app only works with certain Android devices. Please contact MSI for potential applications.

OVERHEAD  
WEIGHING

# MSI Scoreboards Wireless RF

Featuring LaserLight2 Remote Displays



- RF telemetry via 2.4GHz modem (certain part numbers only)
- Six high-intensity red digits (double-row discrete LED)
- Auto Learn mode of communication protocols
- Hold displayed weight (demand input)
- Software selectable standstill mode for no updates while in motion
- Durable weather tight IP66 enclosure
- Adjustable daylight/night intensity
- Non-glare contrast filtered lens
- Mirror (reverse image) feature
- RS-232, 20 mA and RS-485 communications
- Scale Core RF (certain models only)
- Auto sensing 115/230 VAC power supply
- PEMs for VESA flat-wall mount or side-mounting flange available
- Polyethylene breather vent inhibits internal moisture buildup

(Contact MSI for application consultation)

## Specifications

### Enclosure:

NEMA Type 4, IP66

### Display:

Six-digit long-life LED, 4 in or 6 in

### Power:

AC/DC power supply 85 to 265 VAC, 47 to 440Hz/130 to 300 VDC

### Radio Link:

Direct sequence spread spectrum at 2.4GHz

### Radio Link Effective Range:

Typically 100 to 300 ft, line of sight; for longer range consult factory

### Standard Antenna:

1/2 wave 2 dBi, articulated

### Warranty:

One-year limited

### Echo Data Output:

RS-232

## Standard Features

- Tilt mounting bracket
- Integrated data repeater
- AC/DC power supply: 85 to 265 VAC, 47 to 440Hz/130 to 300 VDC

## Part Number/Price

Part #	Description	Est. Weight	Price
178004	LaserLight2, 4 in with ScaleCore RF and tilt bracket		\$2,370.00
178006	LaserLight2, 6 in with ScaleCore RF and tilt bracket		\$2,810.00
178341	Laserlight2, 4 in with tilt bracket		\$2,250.00
178342	Laserlight2, 6 in with tilt bracket		\$2,680.00

## Options/Accessories

Part #	Description	Est. Weight	Price
139309	Long range antenna, 300 m-500 m omni-directional with 9 dBi gain, includes 10 ft/3 m coaxial cable	1 lb	\$485.00
139310	9 dBi gain corner reflector antenna	1 lb	\$480.00
139311	12 dBi gain corner reflector antenna	1 lb	\$510.00
139313	5 dBi gain vehicle/cab mount whip antenna	1 lb	\$150.00
162178	Antenna extension kit, 6 ft		\$465.00
197013	Antenna extension kit, 20 ft		\$495.00
178318	Replacement tilt bracket		\$260.00

## Dimensions

22-inch enclosure (4-inch model)				31-inch enclosure (6-inch model)			
A	22.28 in (565 mm)	C	3.28 in (85 mm)	A	30.63 in (780 mm)	C	3.73 in (95 mm)
B	10.96 in (280 mm)	D	9.80 in (250 mm)	B	13.94 in (355 mm)	D	12.77 in (325 mm)

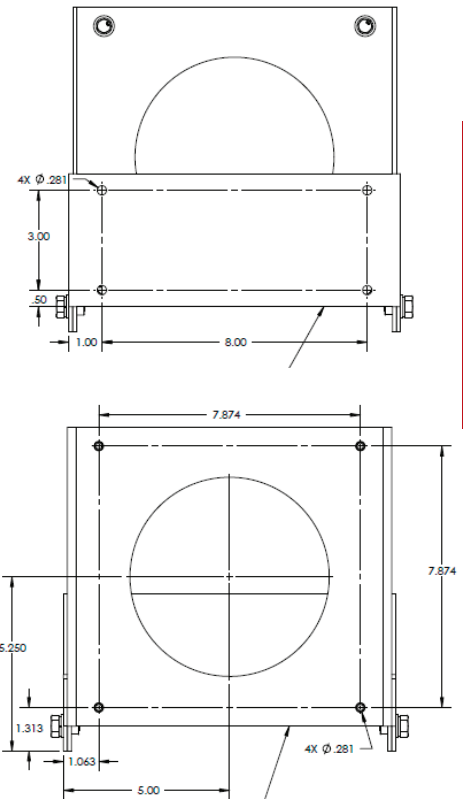
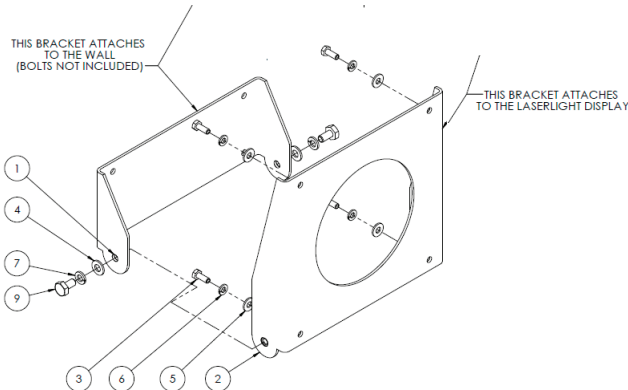
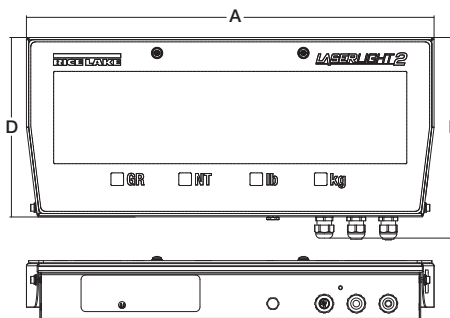

OVERHEAD WEIGHING

# TranSend™ MSI-7000

Wireless Load Cell Interface System



## Standard Features

- Works with any basic digital weight indicator
- Excitation to load cell(s) provided by the transmitter, not the indicator
- Each transmitter/receiver set is individually paired
- Auto-off mode - selectable for 15, 30, 45, 60 minutes or off
- Auto-sleep mode - power down during non-use, power up with weight change or key press
- Serial communication cable included with all transmitters

## Additional HD Features

(Contact MSI for application consultation)

- IP68 milled aluminum enclosure
- Second radio modem available

## Specifications

**Power:**

5 to 6 VDC, 7 to 36 VDC 85 to 265 VAC

**Excitation Voltage:**

Transmitter: +4.8 VDC, 16 x 350 ohm or 32 x 700 ohm load cells

**Standard Antenna:**

1/2 wave 2dBi, articulated

**Frequency:**

Direct sequence spread spectrum at 2.4 GHz, 802.15.4

**Effective Range:**

Typically 100 to 300 ft, line of sight; for longer range consult factory

**Digital I/O:**

Three coil relays available on select models

**Communication Ports:**

Full duplex RS-232

**Circuit Protection:**

RFI, EMI, ESD protection

**Temperature Range:**

-40 °F to 185 °F (-40 °C to 85 °C)

**Enclosure:**

NEMA Type 4 (IP66), aluminum black powder coated (excludes wall cube model)  
MSI-7000HD/MSI-7001HD: IP68

**Additional RF Options:**

Wi-Fi  
Cellular (consult)  
802.15.4 FHSS

**Warranty:**

One-year limited

## Part Number/Price

Part #	Description	Est. Weight	Price
<b>Transmitters</b>			
<b>5-6 VDC Power Input</b>			
159207	Four-channel transmitter, no relays, RF 802.15.4, 2.4 GHz	2 lb	\$985.00
161949	Four-channel transmitter, includes three coil relays, RF 802.15.4, 2.4 GHz	2 lb	\$1,130.00
176648	Four-channel transmitter, no relays, Wi-Fi	2 lb	\$1,040.00
176652	Four-channel transmitter, includes three coil relays, Wi-Fi	2 lb	\$1,180.00
<b>7-36 VDC Power Input</b>			
159470	Four-channel transmitter, no relays, RF 802.15.4, 2.4 GHz	2 lb	\$1,020.00
161951	Four-channel transmitter, includes three coil relays, RF 802.15.4, 2.4 GHz	2 lb	\$1,180.00
176650	Four-channel transmitter, no relays, Wi-Fi	2 lb	\$1,070.00
176653	Four-channel transmitter, includes three coil relays, Wi-Fi	2 lb	\$1,240.00
<b>85-265 VAC Power Input</b>			
159469	Four-channel transmitter, no relays, RF 802.15.4, 2.4 GHz	2 lb	\$1,040.00
161950	Four-channel transmitter, includes three coil relays, RF 802.15.4, 2.4 GHz	2 lb	\$1,210.00
176647	Four-channel transmitter, no relays, Wi-Fi	2 lb	\$1,100.00
176651	Four-channel transmitter, includes three coil relays, Wi-Fi	2 lb	\$1,280.00
<b>Receivers</b>			
<b>5-6 VDC Power Input</b>			
160016	Four-channel receiver to provide an analog output signal: 4-20 mA, 0-20 mA, 0-5 VDC, 0-10 VDC, ±5 VDC, ±10VDC, includes three coil relays, RF 802.15.4, 2.4 GHz	2 lb	\$1,180.00
160017	MSI-7000 four-channel receiver to provide RS232 serial output	2 lb	\$1,080.00
<b>7-36 VDC Power Input</b>			
159478	MSI-7000 four-channel receiver to provide RS232 serial output	2 lb	\$1,125.00
159476	Four-channel receiver to provide an analog output signal: 4-20 mA, 0-20 mA, 0-5 VDC, 0-10 VDC, ±5 VDC, ±10 VDC, includes three coil relays, RF 802.15.4, 2.4 GHz	2 lb	\$1,330.00
<b>85-265 VAC Power Input</b>			
159477	Four-channel receiver to provide RS232 serial output	2 lb	\$1,110.00
159475	Four-channel receiver to provide an analog output signal: 4-20 mA, 0-20 mA, 0-5 VDC, 0-10 VDC, ±5 VDC, ±10 VDC, includes three coil relays, RF 802.15.4, 2.4 GHz	2 lb	\$1,430.00

OVERHEAD WEIGHING

## Options/Accessories

Part #	Description	Price
162172	Charger, TranSend™ for 6V SLA battery	\$67.00
162173	Battery, TranSend 6V SLA	\$130.00
162175	Enclosure, TranSend for 6V SLA battery	\$340.00
160109	AC adaptor, TranSend 6V	\$56.00
143531	Power cord, 6 V SLA battery charger EU	\$29.00
143533	Power cord, 6 V SLA battery charger, Australia	\$51.00
143534	Power cord, 6 V SLA battery charger, UK	\$45.00
160110	265 VAC to 6 VDC wall adapter US/UK/EU/AUS/China	\$56.00
162178	Antenna extension kit, 6 ft coax cable	\$465.00
139309	Antenna kit, long range Omni with 3 m coax cable	\$485.00
139310	Antenna kit, corner reflector 9 dbi with 3 m coax cable	\$480.00
197013	Antenna extension kit, 20 ft	\$495.00
139311	Antenna kit, corner reflector 12 dbi with 3 m coax cable	\$510.00
139312	Antenna kit, Yagi 15 dbi with 3 m coax cable	\$395.00
144345	30 m coaxial cable, for use with non-vehicle mount antenna kits	\$455.00
139313	Antenna kit, vehicle mount. 5 dbi with 5 m coaxial cable	\$150.00
150964	RS-232 13 ft (4 m) serial cable with nine-pin (female) connector	\$190.00
150965	RS-232 13 ft (4 m) serial cable with nine-pin (male) connector	\$170.00
145085	RS-232 serial cable, nine-pin unterminated	\$130.00

# TranSend™ MSI-7001

Wireless Load Cell Interface System



## Standard Features

- Works with any basic digital weight indicator
- Excitation to load cell(s) provided by the transmitter, not the indicator
- Each transmitter/receiver set is individually paired
- Auto-off mode - selectable for 15, 30, 45, 60 minutes or off
- Auto-sleep mode - power down during non-use, power up with weight change or key press
- Serial communication cable included with all transmitters

## Additional HD Features

(Contact MSI for application consultation)

- IP68 milled aluminum enclosure
- Second radio modem available

## Specifications

**Power:**

5 to 6 VDC, 7 to 36 VDC 85 to 265 VAC

**Excitation Voltage:**

Transmitter: +4.8 VDC, 16 x 350 ohm or 32 x 700 ohm load cells

**Standard Antenna:**

1/2 wave 2dBi, articulated

**Frequency:**

Direct sequence spread spectrum at 2.4 GHz, 802.15.4

**Effective Range:**

Typically 100 to 300 ft, line of sight; for longer range consult factory

**Digital I/O:**

Three coil relays available on select models

**Communication Ports:**

Full duplex RS-232

**Circuit Protection:**

RFI, EMI, ESD protection

**Temperature Range:**

-40 °F to 185 °F (-40 °C to 85 °C)

**Enclosure:**

NEMA Type 4 (IP66), aluminum black powder coated (excludes wall cube model)  
MSI-7000HD/MSI-7001HD: IP68

**Additional RF Options:**

Wi-Fi  
Cellular (consult)  
802.15.4 FHSS

**Warranty:**

One-year limited

## Part Number/Price

Part #	Description	Est. Weight	Price
<b>Transmitters</b>			
<b>5-6 VDC Power Input</b>			
160330	Single-channel transmitter, no relays, RF 802.15.4, 2.4 GHz	2 lb	\$930.00
176655	Single-channel transmitter, no relays, Wi-Fi	2 lb	\$980.00
<b>7-36 VDC Power Input</b>			
160329	Single-channel transmitter, no relays, RF 802.15.4, 2.4 GHz	2 lb	\$985.00
176656	Single-channel transmitter, no relays, Wi-Fi	2 lb	\$1,040.00
<b>85-265 VAC Power Input</b>			
160328	Single-channel transmitter, no relays, RF 802.15.4, 2.4 GHz	2 lb	\$1,020.00
176654	Single-channel transmitter, no relays, Wi-Fi	2 lb	\$1,070.00
<b>Receivers</b>			
<b>5-6 VDC Power Input</b>			
160337	Single-channel receiver to provide a mV signal to a digital weight indicator, RF 802.15.4, 2.4 GHz	2 lb	\$985.00
160334	Single-channel receiver to provide an analog output signal: 4-20 mA, 0-20 mA, 0-5 VDC, 0-10 VDC, ±5 VDC, ±10 VDC, RF 802.15.4, 2.4 GHz	2 lb	\$1,040.00
161941	Single-channel receiver to provide RS232 serial output	2 lb	\$770.00
<b>7-36 VDC Power Input</b>			
160336	Single-channel receiver to provide a mV signal to a digital weight indicator, RF 802.15.4, 2.4 GHz	2 lb	\$1,080.00
161939	Single-channel receiver to provide RS232 serial output	2 lb	\$880.00
160333	Single-channel receiver to provide an analog output signal: 4-20 mA, 0-20 mA, 0-5 VDC, 0-10 VDC, ±5 VDC, ±10 VDC, RF 802.15.4, 2.4 GHz	2 lb	\$1,180.00
<b>85-265 VAC Power Input</b>			
160335	Single-channel receiver to provide a mV signal to a digital weight indicator, RF 802.15.4, 2.4 GHz	2 lb	\$1,130.00
161938	Receiver to provide RS232 serial output	2 lb	\$940.00

OVERHEAD WEIGHING



## Options/Accessories

Part #	Description	Price
162177	Cordset, TranSend, pre-wired for use with single channel transmitters or non-relay based receivers	\$130.00
164865	Cable, 4 m, one-channel, mV/V output, LC input	\$135.00
165648	Cable, 5 m, one-channel, mV/V output, LC input	\$155.00
165651	Cable, 10 m, one-channel, mV/V output, LC input	\$220.00
162184	Load cell connector, TranSend, field wireable, 4-6 mm straight. For use with single channel transmitters and all receivers.	\$59.00
162185	Load cell connector, TranSend, field wireable, 6-8 mm straight. For use with single channel transmitters and all receivers.	\$59.00
162186	Load cell connector, TranSend, field wireable, 4-6 mm right angle. For use with single channel transmitters and all receivers.	\$59.00
162187	Load cell connector, TranSend, field wireable, 6-8 mm right angle. For use with single channel transmitters and all receivers.	\$59.00
145084	Cable, 2 m, one-channel, analog output	\$61.00
144400	Cable, 5 m, one-channel, analog output	\$95.00
168903	Cable, 10 m, one-channel, analog output	\$145.00
Consult	Straight connector, analog output, field wire able, 4-6 mM OD	Consult
Consult	Straight connector, analog output, field wire able, 6-8 mM OD	Consult
Consult	Right angle connector, analog output, field wire able, 4-6 mM OD	Consult
Consult	Right angle connector, analog output, field wire able, 6-8 mM OD	Consult
162172	Charger, TranSend™ for 6 V SLA battery	\$67.00
162173	Battery, TranSend 6 V SLA	\$130.00
162175	Enclosure, TranSend for 6 V SLA battery	\$340.00
160109	AC adaptor, TranSend 6 V	\$56.00
143531	Power cord, 6 V SLA battery charger EU	\$29.00
143533	Power cord, 6 V SLA battery charger, Australia	\$51.00
143534	Power cord, 6 V SLA battery charger, UK	\$45.00
160110	265 VAC to 6 VDC wall adapter US/UK/EU/AUS/China	\$56.00
162178	Antenna extension kit, 6 ft coax cable	\$465.00
139309	Antenna kit, long range Omni with 3 m coax cable	\$485.00
139310	Antenna kit, corner reflector 9 dbi with 3 m coax cable	\$480.00
197013	Antenna extension kit, 20 ft	\$495.00
139311	Antenna kit, corner reflector 12 dbi with 3 m coax cable	\$510.00
139312	Antenna kit, Yagi 15 dbi with 3 m coax cable	\$395.00
144345	30 m coaxial cable, for use with non-vehicle mount antenna kits	\$455.00
139313	Antenna kit, vehicle mount. 5 dbi with 5 m coaxial cable	\$150.00
150964	RS-232 13 ft (4 m) serial cable with nine-pin (female) connector	\$190.00
150965	RS-232 13 ft (4 m) serial cable with nine-pin (male) connector	\$170.00
145085	RS-232 serial cable, nine-pin unterminated	\$130.00

**OVERHEAD  
WEIGHING**



**TranSend™ MSI-7000HD**

Wireless Load Cell Interface System

**Standard Features**

- Works with any basic digital weight indicator
- Excitation to load cell(s) provided by the transmitter, not the indicator
- Each transmitter/receiver set is individually paired
- Auto-off mode - selectable for 15, 30, 45, 60 minutes or off
- Auto-sleep mode - power down during non-use, power up with weight change or key press
- Serial communication cable included with all transmitters

**Additional HD Features**

(Contact MSI for application consultation)

- IP68 milled aluminum enclosure
- Second radio modem available

**Specifications****Power:**

5 to 6 VDC, 7 to 36 VDC 85 to 265 VAC

**Excitation Voltage:**

Transmitter: +4.8 VDC, 16 x 350 ohm or 32 x 700 ohm load cells

**Standard Antenna:**

1/2 wave 2dBi, articulated

**Frequency:**

Direct sequence spread spectrum at 2.4 GHz, 802.15.4

**Effective Range:**

Typically 100 to 300 ft, line of sight; for longer range consult factory

**Digital I/O:**

Three coil relays available on select models

**Communication Ports:**

Full duplex RS-232

**Circuit Protection:**

RFI, EMI, ESD protection

**Temperature Range:**

-40 °F to 185 °F (-40 °C to 85 °C)

**Enclosure:**NEMA Type 4 (IP66), aluminum black powder coated (excludes wall cube model)  
MSI-7000HD/MSI-7001HD: IP68**Additional RF Options:**Wi-Fi  
Cellular (consult)  
802.15.4 FHSS**Warranty:**

One-year limited

**Part Number/Price**

Part #	Description	Est. Weight	Price
<b>Transmitters</b>			
<b>5-6 VDC Power Input</b>			
177944	Four-channel 7-36VDC, three coil relays, 802.15.4		\$2,080.00
177997	Four-channel 7-36VDC, three coil relays, Wi-Fi		\$2,090.00
<b>7-36 VDC Power Input</b>			
177945	Four-channel 9-36VDC isolated, three coil relays, 802.15.4		\$2,170.00
177998	Four-channel 9-36VDC isolated, three coil relays, Wi-Fi		\$2,190.00
184002	Half-plate mounted, FHSS, DC (battery) powered (half plate battery power supply sold separately)		Consult
<b>85-265 VAC Power Input</b>			
177942	Four-channel 85-265VAC, three coil relays, 802.15.4		\$2,130.00
177995	Four-channel 85-265VAC, three coil relays, Wi-Fi		\$2,150.00

**Options/Accessories**

Part #	Description	Price
187424	Dual XBee option kit for 7000HD with TNC connector	\$200.00
162178	Antenna extension kit, 6 ft coax cable	\$465.00
139309	Antenna kit, long range Omni with 3 m coax cable	\$485.00
139310	Antenna kit, corner reflector 9 dbi with 3 m coax cable	\$480.00
197013	Antenna extension kit, 20 ft	\$495.00
139311	Antenna kit, corner reflector 12 dbi with 3 m coax cable	\$510.00
139312	Antenna kit, Yagi 15 dbi with 3 m coax cable	\$395.00
144345	30 m coaxial cable, for use with non-vehicle mount antenna kits	\$455.00
139313	Antenna kit, vehicle mount. 5 dbi with 5 m coaxial cable	\$150.00
148624	RS-232/RS-485 serial cable	\$135.00
143348	Cordset IP68 5-pin male	\$130.00

OVERHEAD  
WEIGHING



### Standard Features

- Works with any basic digital weight indicator
- Excitation to load cell(s) provided by the transmitter, not the indicator
- Each transmitter/receiver set is individually paired
- Auto-off mode - selectable for 15, 30, 45, 60 minutes or off
- Auto-sleep mode - power down during non-use, power up with weight change or key press
- Serial communication cable included with all transmitters

### Additional HD Features

(Contact MSI for application consultation)

- IP68 milled aluminum enclosure
- Second radio modem available

### Specifications

**Power:**

5 to 6 VDC, 7 to 36 VDC 85 to 265 VAC

**Excitation Voltage:**

Transmitter: +4.8 VDC, 16 x 350 ohm or 32 x 700 ohm load cells

**Standard Antenna:**

1/2 wave 2dBi, articulated

**Frequency:**

Direct sequence spread spectrum at 2.4 GHz, 802.15.4

**Effective Range:**

Typically 100 to 300 ft, line of sight; for longer range consult factory

**Digital I/O:**

Three coil relays available on select models

**Communication Ports:**

Full duplex RS-232

**Circuit Protection:**

RFI, EMI, ESD protection

**Temperature Range:**

-40 °F to 185 °F (-40 °C to 85 °C)

**Enclosure:**

NEMA Type 4 (IP66), aluminum black powder coated (excludes wall cube model)  
 MSI-7000HD/MSI-7001HD: IP68

**Additional RF Options:**

Wi-Fi  
 Cellular (consult)  
 802.15.4 FHSS

**Warranty:**

One-year limited

### Part Number/Price

Part #	Description	Est. Weight	Price
<b>Transmitters</b>			
<b>5-6 VDC</b>			
178010	Two-channel 5-6VDC, 802.15.4		\$1,160.00
178018	Two-channel 5-6VDC, Wi-Fi		\$1,250.00
<b>7-36 VDC</b>			
178011	Two-channel 7-36VDC, 802.15.4		\$1,240.00
178019	Two-channel 7-36VDC, Wi-Fi		\$1,260.00
<b>85-265 VAC Isolated</b>			
178012	Two-channel 9-36VDC isolated, 802.15.4		\$1,250.00
178020	Two-channel 9-36VDC isolated, Wi-Fi		\$1,330.00
<b>85-265 VAC</b>			
178021	Two-channel 85-265VAC, 802.15.4		\$1,280.00
178017	Two-channel 85-265VAC, Wi-Fi		\$1,310.00

### Options/Accessories

Part #	Description	Price
162172	Charger, TranSend™ for 6 V SLA battery	\$67.00
162173	Battery, TranSend 6V SLA	\$130.00
162175	Enclosure, TranSend for 6 V SLA battery	\$340.00
160109	AC adaptor, TranSend 6 V	\$56.00
143531	Power cord, 6 V SLA battery charger EU	\$29.00
143533	Power cord, 6 V SLA battery charger, Australia	\$51.00
143534	Power cord, 6 V SLA battery charger, UK	\$45.00
160110	265 VAC to 6 VDC wall adapter US/UK/EU/AUS/China	\$56.00
162178	Antenna extension kit, 6 ft coax cable	\$465.00
139309	Antenna kit, long range Omni with 3 m coax cable	\$485.00
139310	Antenna kit, corner reflector 9 dbi with 3 m coax cable	\$480.00
197013	Antenna extension kit, 20 ft	\$495.00
139311	Antenna kit, corner reflector 12 dbi with 3 m coax cable	\$510.00
139312	Antenna kit, Yagi 15 dbi with 3 m coax cable	\$395.00
144345	30 m coaxial cable, for use with non-vehicle mount antenna kits	\$455.00
139313	Antenna kit, vehicle mount. 5 dbi with 5 m coaxial cable	\$150.00
148624	RS-232/RS-485 serial cable	\$135.00
143348	Cordset IP68, 5-pin	\$130.00

**OVERHEAD WEIGHING**

# ScaleCore Webserver

For use with ScaleCore based MSI brand scales and indicators

**NEW**



Approvals



## Part Number/Price

Part #	Description	Price
207943	ScaleCore Webserver, 5 VDC and PoE	\$3,400.00
209704	ScaleCore Webserver, 7-14 VDC and PoE	\$3,400.00
210817	ScaleCore Webserver, 85-265 VAC and PoE wall cube	\$3,400.00

## Options/Accessories

Part #	Description	Price
Consult	Extended Range Antennas	Consult
213559	MSI-8000 handheld remote display with Wi-Fi, (only to be used with MSI ScaleCore Webserver systems and applications)	\$1,460.00

## Standard Features

- Display and control multiple ScaleCore based scales, indicators, remote displays and receivers through network connected devices using a web browser, including cell phones, tablets, and PCs.
- **Contact MSI for application consultation.**
- Capable of functioning either with an existing Wi-Fi network or as its own Wi-Fi router
- Can be powered by a dedicated power input or directly through the Ethernet cable where PoE (Power over Ethernet) is supported
- RS-232 communications at up to 460 Kbps
- Scale / load cell summing
- Tiered login to limit scale functionality for different levels of users

## Specifications

### Minimum System Requirements:

Will display on any device with a web browser supporting HTML 5  
 Connected ScaleCore based MSI scales and indicators are required to have the optional Wi-Fi radio module

### Connectivity:

Wi-Fi 2.4 GHz IEEE 802.11g  
 Gigabit Ethernet  
 2 × USB 2.0 Interface  
 RS-232 Serial

### Status Annunciators:

Units (lb, kg, short tons (tn), metric tons (t), (NONE) gross/net, motion, center of zero

### Operating Temperature:

-10 °C to 40 °C (14 °F to 104 °F)

### Effective Range:

Typically 100 to 300 ft, line of sight; for longer range consult factory

### Enclosure:

IP65, aluminum black powder coated (excludes 85 to 265 VAC model)

### Power:

5 to 6 VDC, 7 to 14 VDC, 85 to 265 VAC, PoE

### Warranty:

One year limited

### Approvals:

NTEP CC 21-098 Classes III and IIIL at 10,000d

OVERHEAD  
WEIGHING



# NEW

## ScaleCore Webserver

For use with ScaleCore based MSI brand scales and indicators

Dimensions			
A	8.54 in (217 mm)	H	2.23 in (57 mm)
B	8.09 in (205 mm)	I	9.13 in (232 mm)
C	4.70 in (119 mm)	J	7.40 in (188 mm)
D	3.97 in (101 mm)	K	4.90 in (124 mm)
E	3.47 in (88 mm)	L	4.50 in (114 mm)
F	0.17 in (4 mm)	M	4.70 in (119 mm)
G	0.25 in (6 mm)		

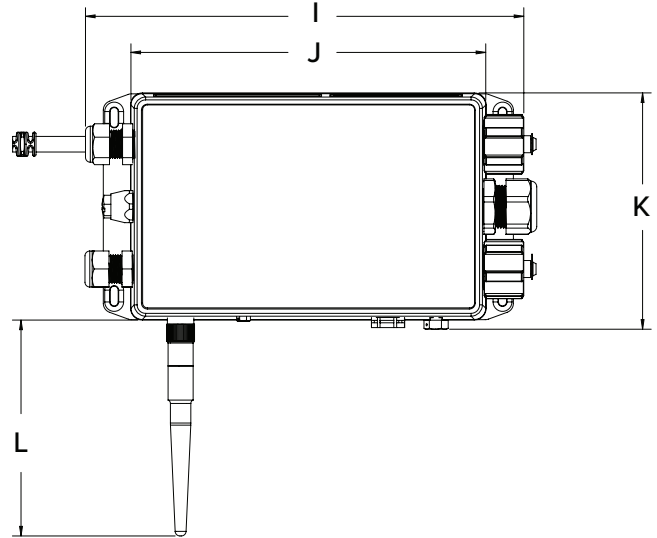
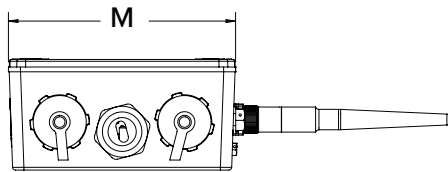
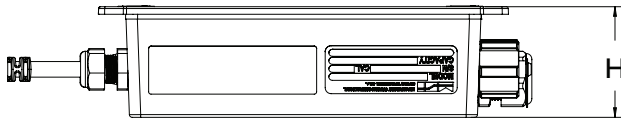
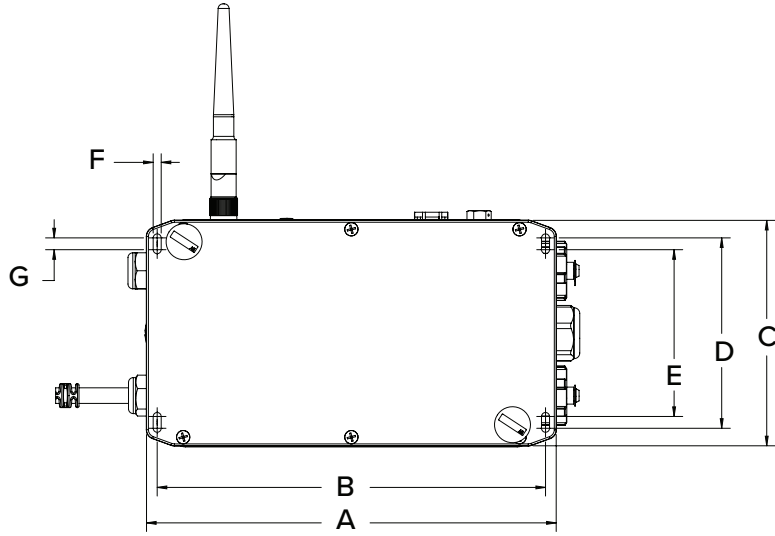

**OVERHEAD WEIGHING**

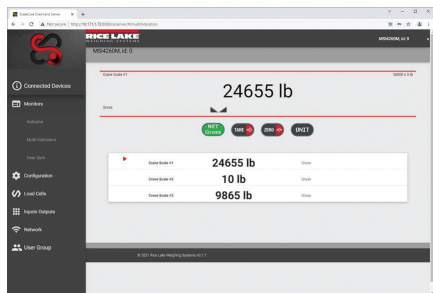

Computer Screenshot

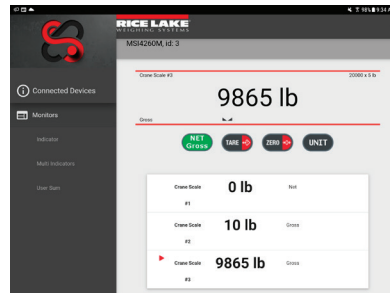

Tablet Screenshot

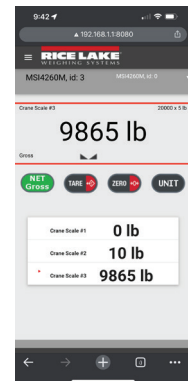

Phone Screenshot

