

SCT-1PX-Ethernet/IP

Digital Weight Transmitter

Quick Start Guide

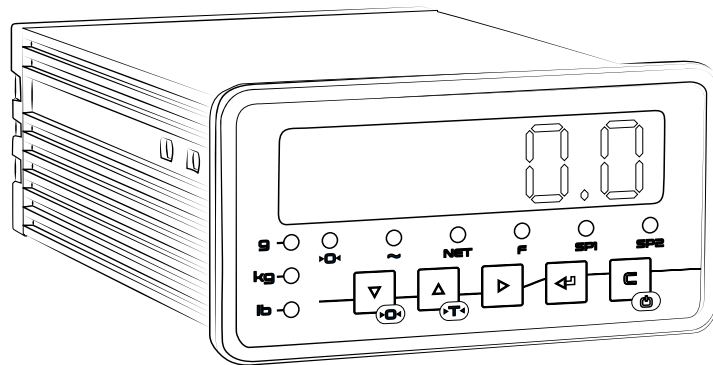

© Rice Lake Weighing Systems. All rights reserved.

Rice Lake Weighing Systems® is a registered trademark of
Rice Lake Weighing Systems.

All other brand or product names within this publication are trademarks or
registered trademarks of their respective companies.

All information contained within this publication is, to the best of our knowledge, complete and accurate at the
time of publication. Rice Lake Weighing Systems reserves the right to make changes to the technology, features,
specifications and design of the equipment without notice.

The most current version of this publication, software, firmware and all other product
updates can be found on our website:

www.ricelake.com

1. Electrical Diagrams

4-WIRE CONNECTION

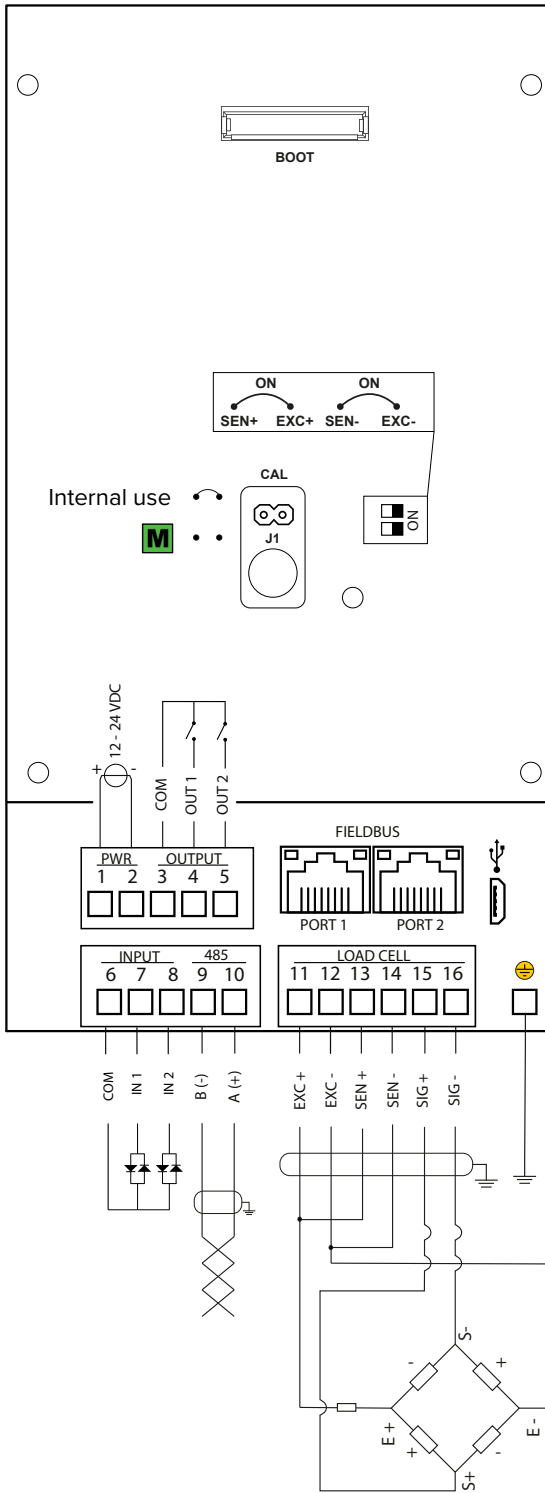

6-WIRE CONNECTION

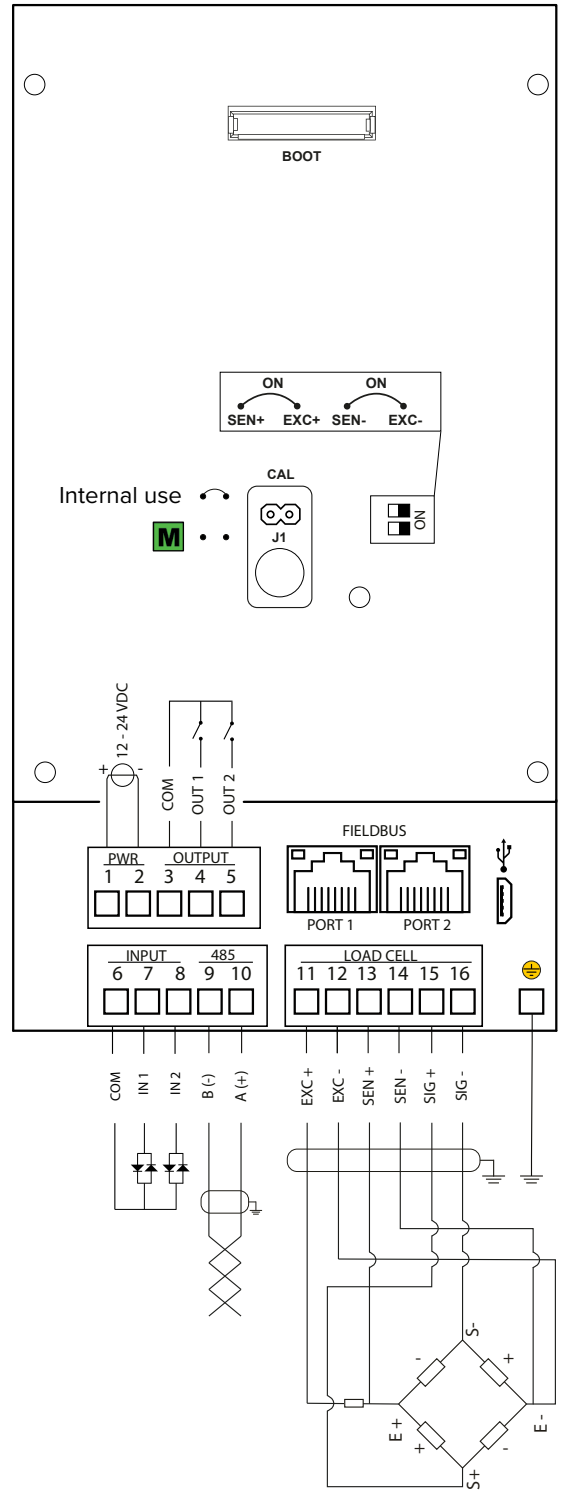

Load cells excitation: 5 V
Load cells output: 6 mV/V max



For UL approved models:
equipment to be powered by
12-24 VDC LPS or Class 2 power
source.



INPUT: 12 - 48 VDC
OUTPUT: 48VAC or 60VDC, 0.5 A
max



CONSUMPTION: 1 W max
(without load cells)

2. Configuration Menu and Weighing Mode Key Functions

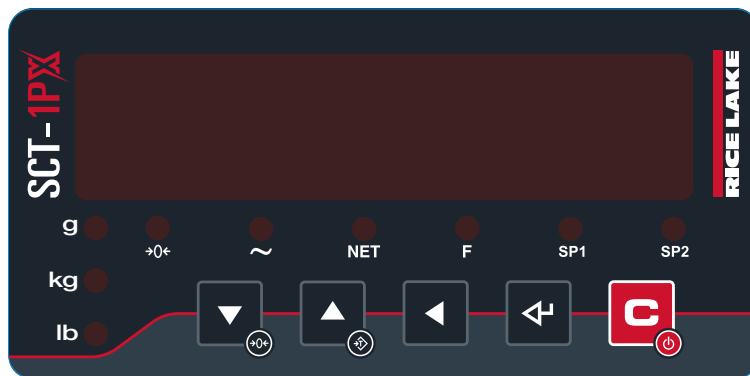

Symbol	Description
▼	Semi-automatic zeroing. Decreases the selected digit.
▲	Semi-automatic tare. Increases the selected digit.
▶	Activates the function. Selects the digit to be changed.
←	Confirms a value. Prints / Transmits data.
C	Reboots the transmitter.

Symbol	Description
▷0◁	Gross weight on zero.
~	Unstable weight.
NET	A tare is active.
F	A special function is active.
SP1	Output 1 is active.
SP2	Output 2 is active.
g kg lb	Unit of measure.

3. Function of the keys in the menu

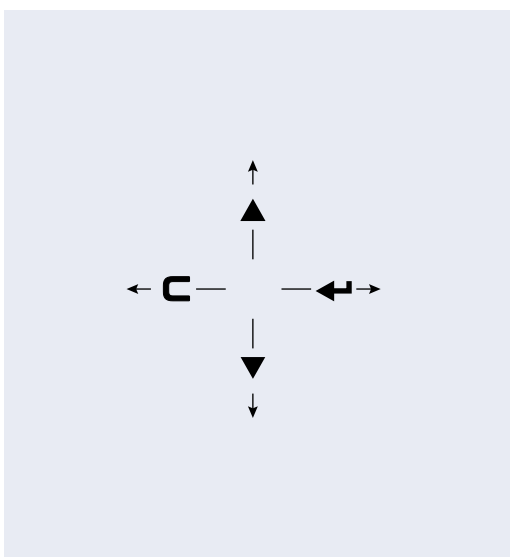

- ▲ Previous parameter.
- ▼ Next parameter.
- ← Access the parameter / confirm setting.
- C Exit a parameter (without saving).

FUNCTION OF THE KEYS WHEN ENTERING NUMBERS

- ▲ Increases the selected digit.
- ▼ Decreases the selected digit.
- ▶ Selects the next digit.
- ← Confirms the value.
- C Resets the value.
If pressed again, exits entering.

4. Configuration Menu

1. Reboot the weight transmitter
2. Press the **▶** key when display shows the *BBBBBB* message:

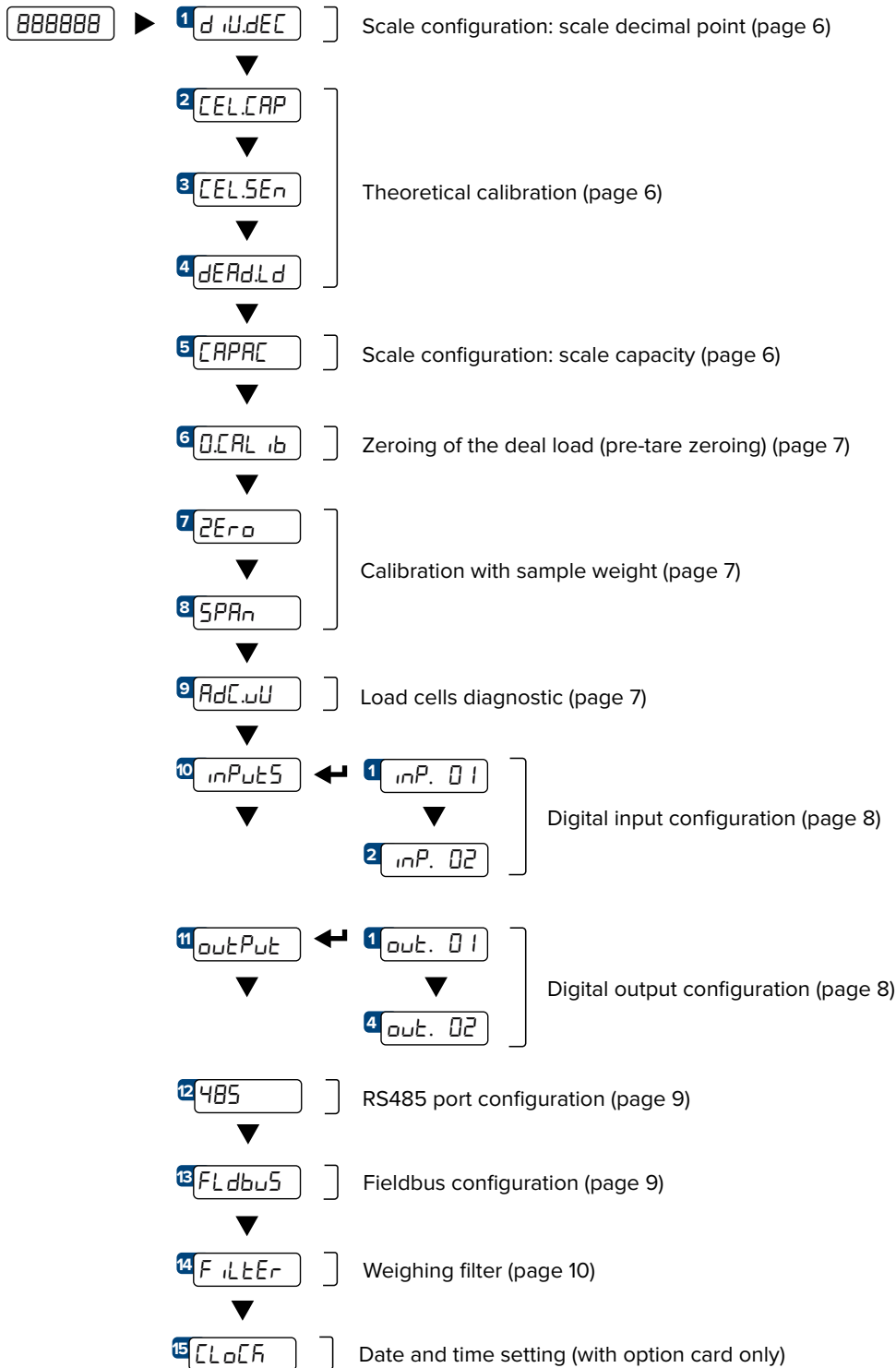

HOW TO EXIT THE MENU AND STORE YOUR CONFIGURATION

Press **C** key many times until *SAVEP* message will appear; press **←** to store or press **C** to exit without storing.

5. Maximum Scale Capacity, Increment and Decimal Point Settings

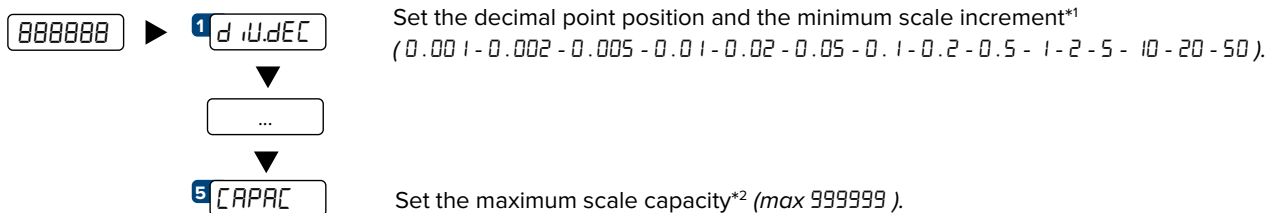

Examples:

For a 60000 kg scale, with 2 kg

increment:

d.u.dEC = 2

CAPAC = 60000

For a 10000 g scale, with 0,1 g increment:

d.u.dEC = 0.1

CAPAC = 10000.0

For a 3000 kg scale, with 0,05 kg

increment:

d.u.dEC = 0.05

CAPAC = 3000.00

*¹ Increment = the amount that the scale will increment by as weight is added or removed.

*² Maximum capacity = the maximum weight that can be measured using the scale you are creating.

6. Theoretical Calibration

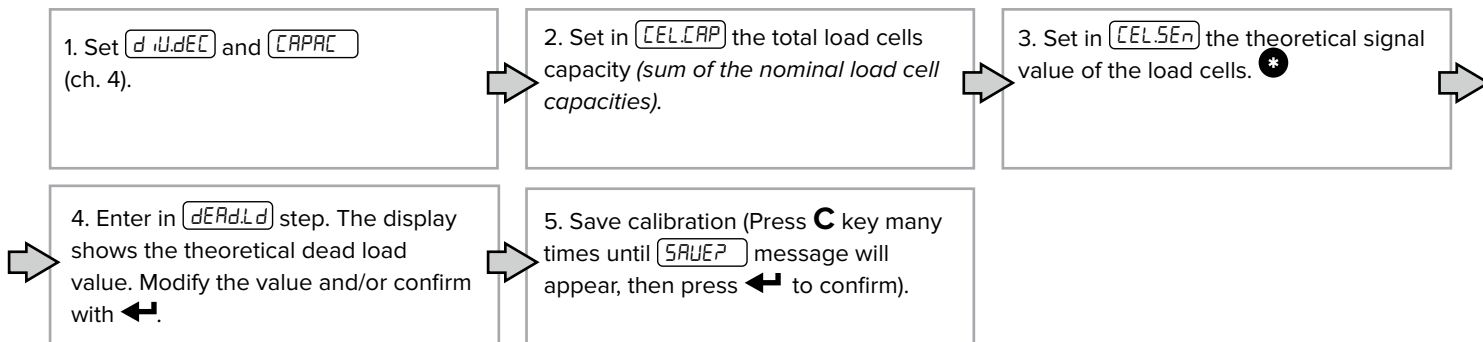
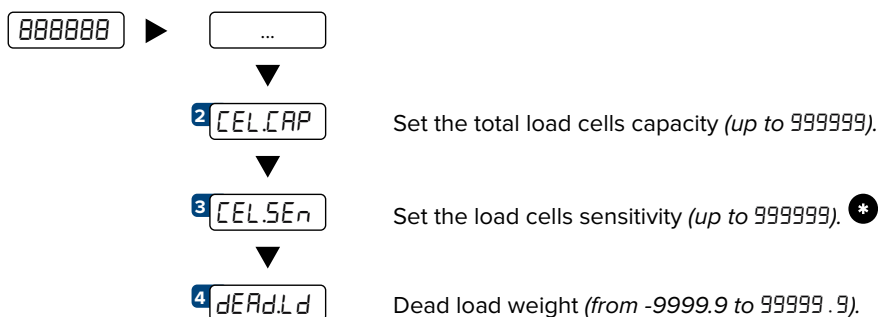

7. Zeroing the Tare (pre-tare zeroing)

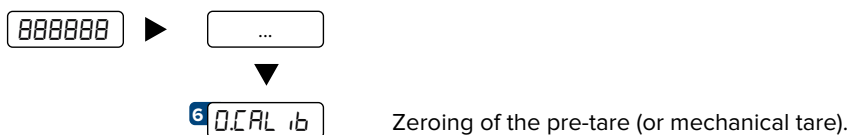

This functionality allows to zero the weigh of the scale structure (e.g. empty silo, conveyor, etc.) without changing the calibration in memory.

8. Calibration with Sample Weight

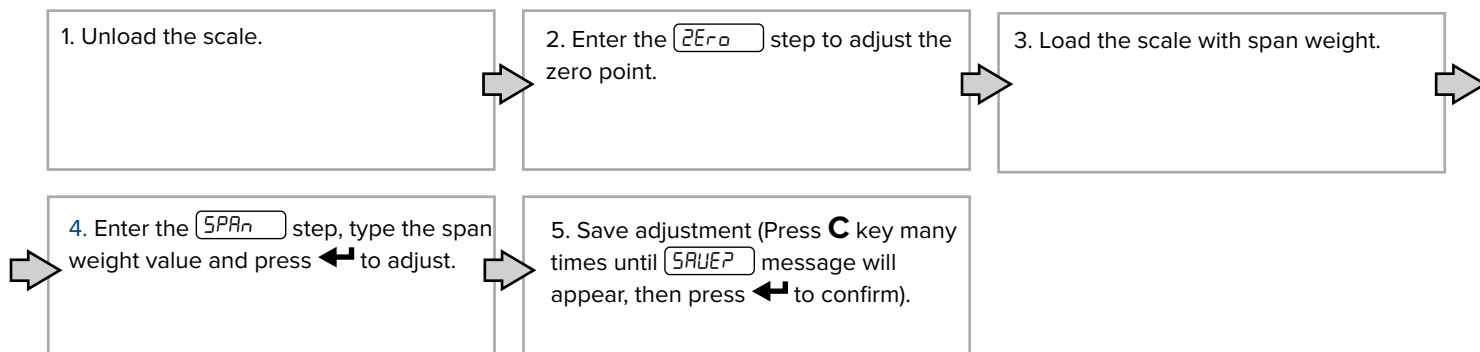
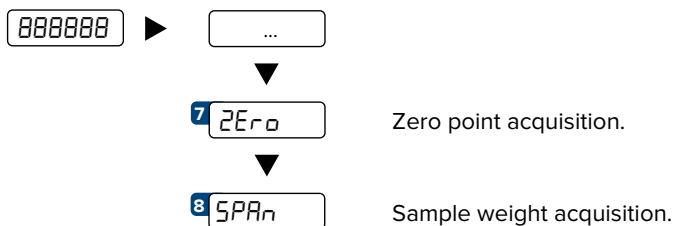

9. Load Cell μ V/V Diagnostic

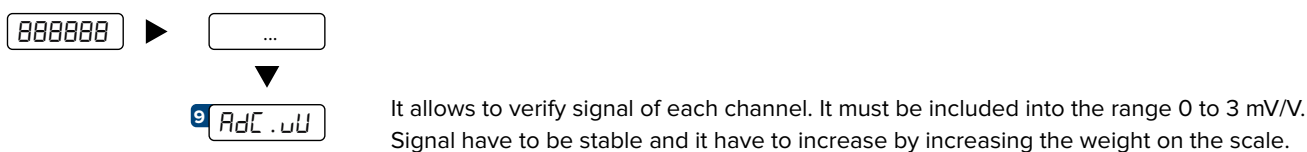

10. Input Settings

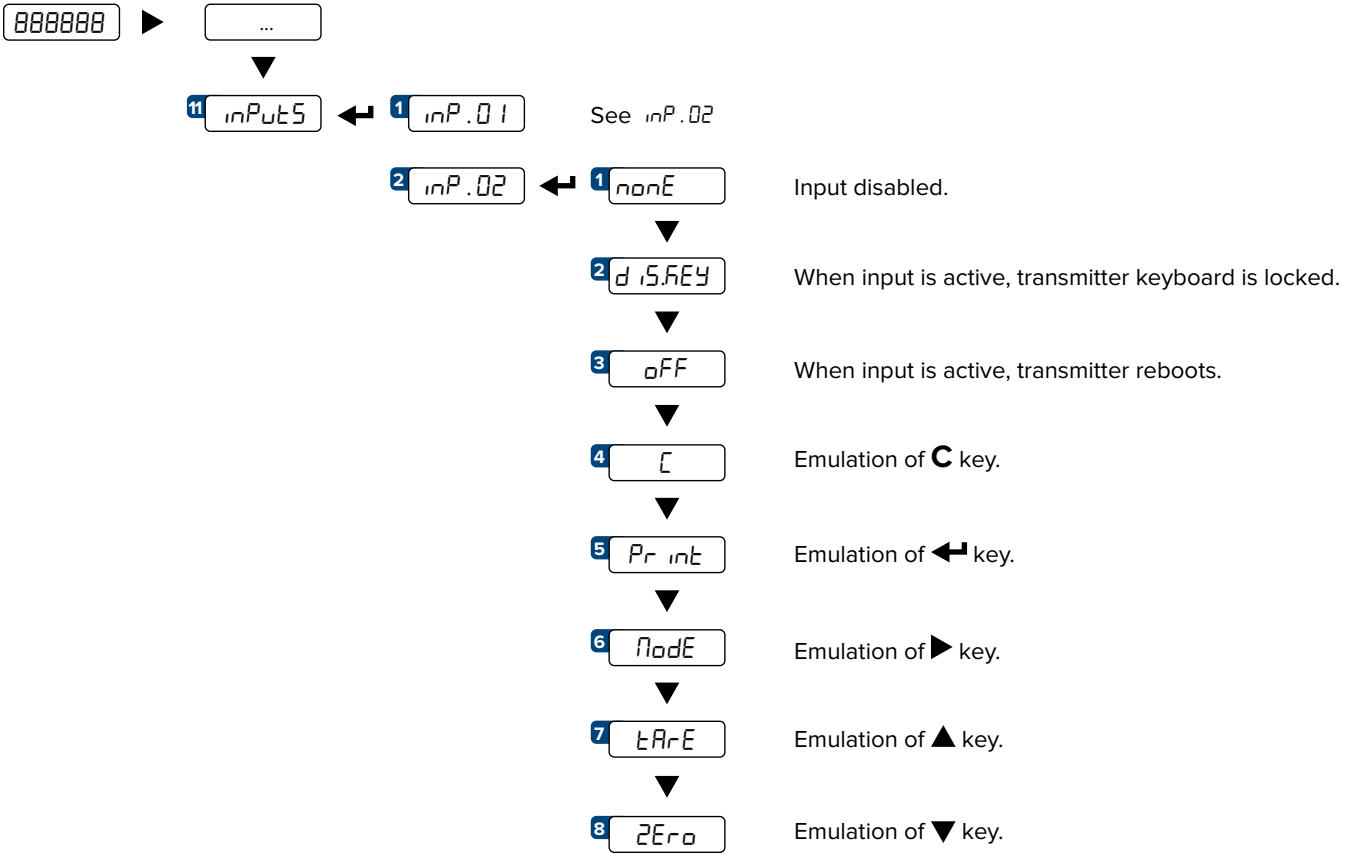

11. Output Settings

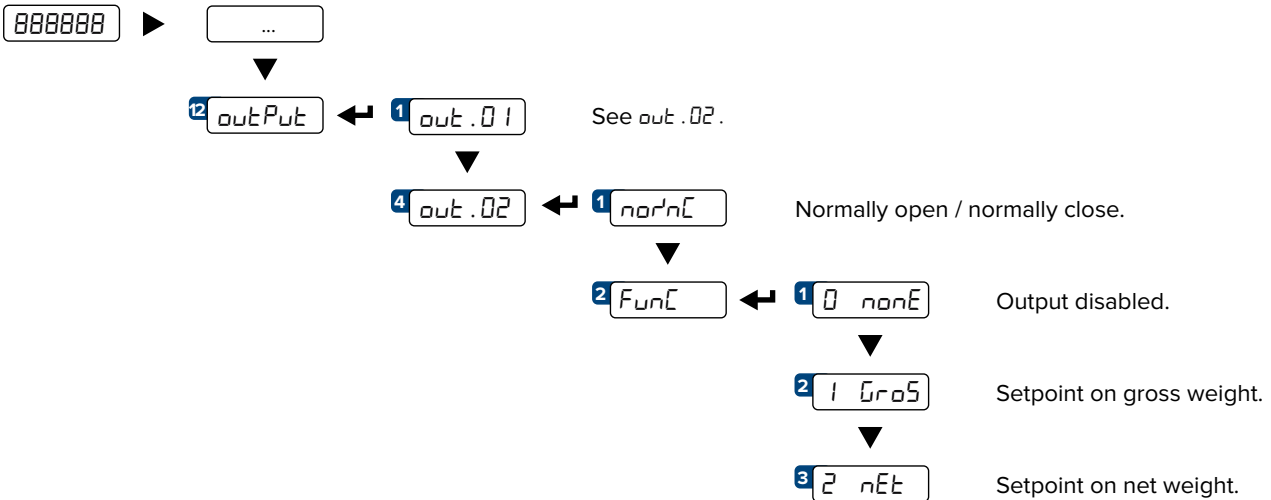

11.1 HOW TO PROGRAM SETPOINTS

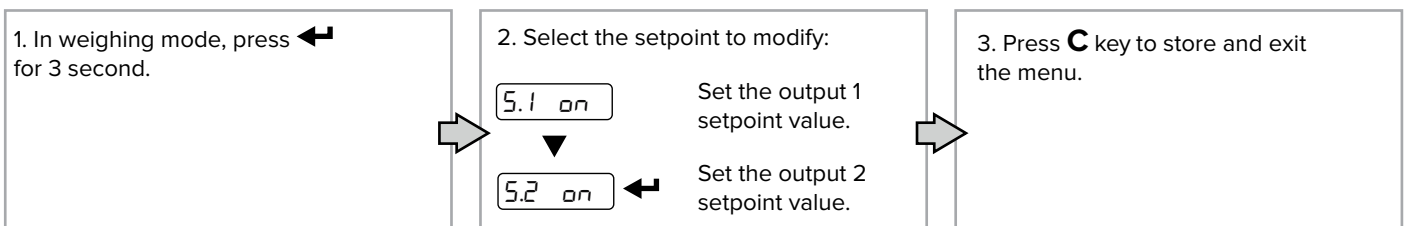

Refer to the technical manual for more information.

12. RS485 Port

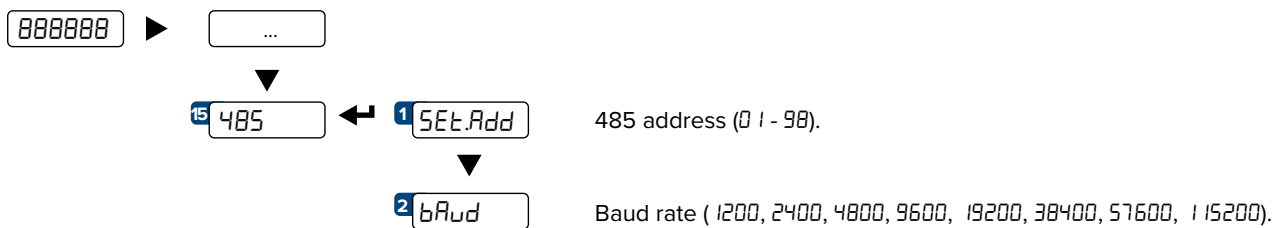

13. Fieldbus Settings

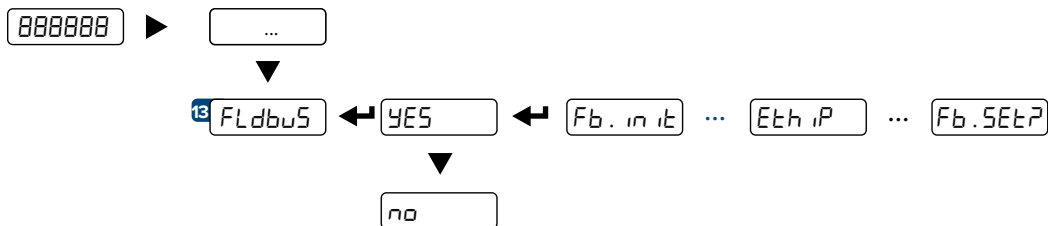

Set the IP address:

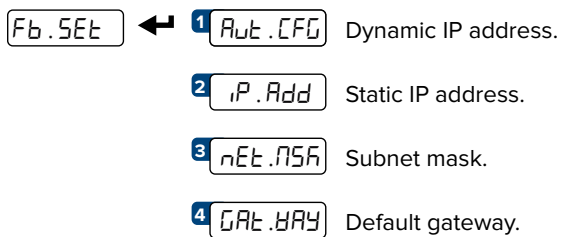

Refer to the Fieldbus manual for more information.

14. Weighing Filter

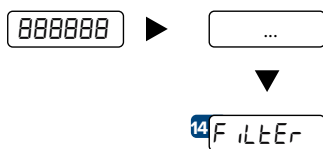

The active weighing filter is displayed, alternating with the weight value.
Press ▲ and ▼ keys to scroll through the available filters (from slowest to fastest, F1 - F11).

15. Programming Errors

MESSAGE	DESCRIPTION	SOLUTION
<i>PrEC.</i>	Calibration error	First calibrate the zero point (<i>ZERo</i>), then proceed with the sample weight acquisition (<i>SPRn</i>) (page 7).
<i>Err.Pnt</i>	Calibration error	Check the connection of the load cell. Check that the cell signal is stable, valid and greater than that of the previously acquired point.
<i>Er 11</i>	Calibration error	Increase the calibration weight.
<i>Er 12</i>	Calibration error	Check that the signal coming from the cell increases upon the increasing of the weight loaded on the scale.
<i>Er 37</i>	Calibration error	Repeat the calibration, checking that the capacity and division have been correctly set.
<i>Er 39</i>	Instrument not configured	Transmitter needs to be configured.
<i>C.Er. 36</i>	Calibration error	Check that the signal coming from the load cell is not negative.
<i>C.Er. 37</i>	Calibration error	Check that the signal coming from the load cell is not negative.
<i>Err.NoE</i>	Weight unstable	Check in <i>AdC . uU</i> parameter that the signal is stable. If the connection of the cells is with 4 wires, check that the sense jumpers are inserted.
<i>AdC . Err</i>	A/D converter error	Converter failure. Reboot the instrument.
<i>CEL . Err</i>	Global load cell error	Signal anomaly: check the load cells connection.

16. EthernetIP

16.1 ETHERNETIP REGISTERS

Data	Byte	DESCRIPTION															
Gross weight	0 _(MSB)	Bytes 1, 2, 3 and 4 contain the Gross Weight value.															
	1																
	2																
	3 _(LSB)																
Net weight	4 _(MSB)	Bytes 5, 6, 7 and 8 contain the Net Weight value.															
	5																
	6																
	7 _(LSB)																
Input status register	8 _(MSB)	<table border="1"> <thead> <tr> <th>Bit 15_(msb)</th> <th>Bit 14</th> <th>Active Channel</th> </tr> </thead> <tbody> <tr> <td>0</td> <td>0</td> <td>Channel 1</td> </tr> <tr> <td>0</td> <td>1</td> <td>Channel 2</td> </tr> <tr> <td>1</td> <td>0</td> <td>Channel 3</td> </tr> <tr> <td>1</td> <td>1</td> <td>Channel 4</td> </tr> </tbody> </table>	Bit 15 _(msb)	Bit 14	Active Channel	0	0	Channel 1	0	1	Channel 2	1	0	Channel 3	1	1	Channel 4
	Bit 15 _(msb)	Bit 14	Active Channel														
0	0	Channel 1															
0	1	Channel 2															
1	0	Channel 3															
1	1	Channel 4															
9 _(LSB)	Bit 7 _(msb) 1 = Scale unloaded (gross weight = 0). Bit 6 Tare PT (1 = PT tare is active). Bit 5 Tare (1 = Tare is active). Bit 4 Overload condition (0 = No; 1 = Overload). Bit 3 Underload condition (0 = No; 1 = Underload). Bit 2 Weight Stability (0 = Unstable; 1 = Stable). Bit 1 Gross Weight Polarity (0 = "+"; 1 = "-"). Bit 0 Net Weight Polarity (0 = "+"; 1 = "-").																
Command status register	10 _(MSB)	Last received command.															
	11 _(LSB)	Bit 7 _(msb) Last command result. Bit 6 Last command result. Bit 5 Last command result. Bit 4 Last command result. Bit 3 Counting of processed commands. Bit 2 Counting of processed commands. Bit 1 Counting of processed commands. Bit 0 _(lsb) Counting of processed commands.															
Output status register	12 _(MSB)	No Function.															
	13 _(LSB)	Bit 7 _(msb) No function. ... Bit 2 No function. Bit 1 Digital output 2 status (0 = OFF; 1 = ON). Bit 0 _(lsb) Digital output 1 status (0 = OFF; 1 = ON).															
Selected page	14 _(MSB)	Shows the value of the selected page (3001).															
	15 _(LSB)																
μV	16 _(MSB)	μV value.															
	17 _(LSB)																



This manual contains the main registers for reading data / sending commands. Refer to the Fieldbus protocol manual for more registers.

16.2 ETHERNETIP REGISTERS FOR COMMAND SENDING

Data	Byte	DESCRIPTION																		
<i>Not used</i>	0	Always 0.																		
<i>Command</i>	1	Main available commands:																		
		<table border="1"> <thead> <tr> <th>Value</th> <th>Command</th> </tr> </thead> <tbody> <tr> <td>00 Hex</td> <td>No command</td> </tr> <tr> <td>01 Hex</td> <td>Scale zeroing</td> </tr> <tr> <td>02 Hex</td> <td>Tare</td> </tr> <tr> <td>03 Hex</td> <td>Preset Tare</td> </tr> <tr> <td>0A Hex</td> <td>Setpoint 1 setting</td> </tr> <tr> <td>0B Hex</td> <td>Setpoint 2 setting</td> </tr> <tr> <td>19 Hex</td> <td>Digital output setting</td> </tr> <tr> <td>22 Hex</td> <td>Reboot the weight transmitter</td> </tr> </tbody> </table>	Value	Command	00 Hex	No command	01 Hex	Scale zeroing	02 Hex	Tare	03 Hex	Preset Tare	0A Hex	Setpoint 1 setting	0B Hex	Setpoint 2 setting	19 Hex	Digital output setting	22 Hex	Reboot the weight transmitter
		Value	Command																	
		00 Hex	No command																	
		01 Hex	Scale zeroing																	
		02 Hex	Tare																	
		03 Hex	Preset Tare																	
		0A Hex	Setpoint 1 setting																	
		0B Hex	Setpoint 2 setting																	
19 Hex	Digital output setting																			
22 Hex	Reboot the weight transmitter																			
<i>Parameter 1</i>	2 _(MSB)	First parameter of the command. Parameter is always expressed in absolute mode (no decimals, no sign).																		
	3																			
	4																			
	5 _(LSB)																			
<i>Parameter 2</i>	6 _(MSB)	Second parameter of the command. Parameter is always expressed in absolute mode (no decimals, no sign).																		
	7																			
	8																			
	9 _(LSB)																			
	10 _(MSB)	Used in advanced configuration, refer to the complete Fieldbus manual for further information.																		
	...																			
	31 _(LSB)																			

EXAMPLE 1

For zeroing the weight on the scale:

1. Set the command in byte 2

Byte	Value
1	00 Hex
2	01 Hex

EXAMPLE 2

For setting a preset tare of 1000 kg:

1. Set the tare value in parameter 1 (byte 3, 4, 5, 6)
2. Set the command in byte 2

Byte	Value
1	00 Hex
2	03 Hex
3 _(MSB)	00 Hex
4	00 Hex
5	03 Hex
6 _(LSB)	E8 Hex



This manual contains the main registers for reading data / sending commands.
Refer to the Fieldbus protocol manual for more registers.



© Rice Lake Weighing Systems Content subject to change without notice.

230 W. Coleman St. • Rice Lake, WI 54868 • USA USA: 800-472-6703 • International: +1-715-234-9171