

Medical Scales

TABLE OF CONTENTS

RL-330HHD/RL-330HHL	750	260-10-1	773
<i>Dial Home Health Scale</i>		<i>Bariatric Handrail Scale</i>	
DHH-10	751	250-10-2	774
<i>Digital Home Health Scale</i>		<i>Bariatric Handrail Scale</i>	
RL-MPS	752	250-10-4	775
<i>Mechanical Physician Scale</i>		<i>Bariatric Handrail Scale</i>	
RL-MPS-10	753	RL-MCS	776
<i>Mechanical Physician Scale</i>		<i>Rice Lake Mechanical Chair Scale</i>	
RL-MPS-20	754	560-10-1	777
<i>Mechanical Physician Scale</i>		<i>Digital Chair Scale</i>	
RL-MPS-30	755	550-10-1	778
<i>Mechanical Physician Scale</i>		<i>Digital Chair Scale</i>	
RL-MPS-40	756	D300 SERIES	779
<i>Mechanical Physician Scale</i>		<i>Wireless Wheelchair Scale</i>	
RL-MPS-50	757	350-10-3M	780
<i>Mechanical Physician Scale</i>		<i>Dual-ramp Wheelchair Scale</i>	
150-10-5	758	350-10-2	781
<i>Digital Physician Scale</i>		<i>Single-Ramp Wheelchair Scale</i>	
150-10-6	760	350-10-7	782
<i>Digital Physician Scale</i>		<i>Single-ramp Wheelchair Platform Scale</i>	
150-10-7	762	350-10-3	783
<i>Digital Physician Scale</i>		<i>Dual-ramp Wheelchair Scale</i>	
160-10-7N	763	350-10-4	784
<i>Digital Athletic Low-profile Scale</i>		<i>Dual-ramp Wheelchair Scale</i>	
RL-WMS-10	764	350-10-8	785
<i>Wall Mount Stadiometer</i>		<i>Dual-ramp Wheelchair Platform Scale</i>	
RL-MIS	765	RL-350-5	786
<i>Mechanical Baby Scale</i>		<i>Single-ramp Portable Bariatric Wheelchair Scale</i>	
RL-MIS-20	766	RL-350-6	787
<i>Mechanical Baby Scale</i>		<i>Dual-ramp Portable Bariatric Wheelchair Scale</i>	
DIGITAL BABY SCALE - SUSPENDED INFANT SCALE	767	SB-1150 SUMMIT™	788
		<i>Bariatric Wheelchair Scale</i>	
RL-DBS	768	SD-1150-WP	789
<i>Digital Baby Scale</i>		<i>Dialysis Wheelchair Scale</i>	
RL-DBS-2	769	<i>Pit Frame Concrete Details</i>	
<i>Digital Baby Scale</i>		350-10-8S	791
D400	770	<i>Digital Stretcher Scales</i>	
<i>Adult and Child Scale</i>			
650-10-1	771		
<i>Neonatal Scale</i>			
RL-PMM	772		
<i>Pediatric Measuring Mat</i>			
RL-PCT-10	772		
<i>Pediatric Circumference Tape</i>			

Product names, logos, brands and other trademarks featured or referred to within this publication are the property of their respective trademark holders.

RL-330HHD/RL-330HHL

Dial Home Health Scale



Model RL-330HHD



Model RL-330HHL

Specifications

Capacity:

RL-330HHL: 330 lb x 1 lb

RL-330HHD: 330 lb x 1 lb (150 kg x 0.5 kg)

Warranty:

One-year limited warranty

Standard Features

- Durable steel base and platform
- Non-slip mat
- Large dial display
- Units of measure: lb (RL-330HHL); lb, kg (RL-330HHD)
- Colorful markers to track weight values

Part Number/Price

Part #	Model #	Capacity	Price
110592	RL-330HHL	330 lb x 1 lb (lb markings only)	\$66.00
113500	RL-330HHD	330 lb x 1 lb (150 kg x 0.5 kg) (lb and kg)	\$66.00

Shipping Weight

Part #	Model #	L (in)	W (in)	H (in)	Package Wgt. (lb)	Dim Wgt. (lb)	Shipping Wgt. (lb)
110592	RL-330HHL	19	13	5	9	9	9
113500	RL-330HHD	19	12	6	9	10	10

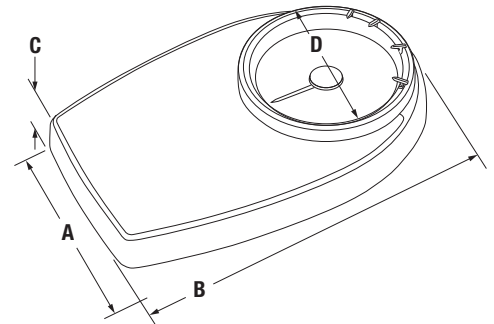

Dimensions

	Inches	Centimeters
A	11.2	28.5
B	16.9	43.0
C	2.5	6.4
D	7.9	20.1

Specifications

Capacity:

440 lb x 0.2 lb (200 kg x 0.1 kg)

Dimensions:

(W x L x H) 15.4 in x 11.8 in x 1 in

Battery Type:

(2) AAA alkaline batteries (included)

Display

Digit size: 1.75 in

Warranty:

One-year limited warranty

Approvals:

CE Marked

DHH-10BT:

Designed to work with AccuroFit App available for Apple and Android



Model DHH-10

Standard Features

- 8 mm tempered safety glass weighing surface
- Low battery indication
- Display lb or kg
- Large LCD display

APPROVALS



Part Number/Price

Part #	Model #	Capacity	Price
Single Carton			
201124	DHH-10	440 lb x 0.2 lb (200 kg x 0.1 kg)	\$68.00
201125	DHH-10BT	440 lb x 0.2 lb (200 kg x 0.1 kg) with Bluetooth®	\$81.00

Shipping Weight

Part #	Model #	L (in)	W (in)	H (in)	Package Wgt. (lb)	Dim Wgt. (lb)	Shipping Wgt. (lb)
Single Carton							
201124	DHH-10	17	13	2	6.5	3.0	6.5
201125	DHH-10BT	17	13	2	6.5	3.0	6.5

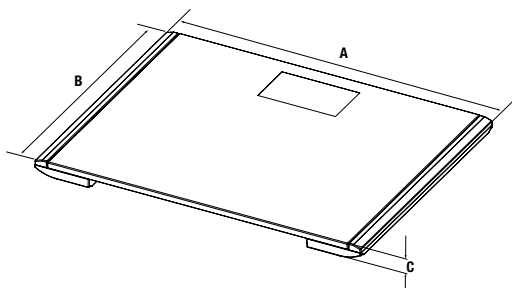

Dimensions

	Inches	Centimeters
A	15.4	39.0
B	11.8	30.0
C	1.0	2.5

RL-MPS

Mechanical Physician Scale



Model RL-MPS



Specifications

- Capacity:**
440 lb x 4 oz (200 kg x 100 g)
- Platform Dimensions:**
(W x L x H) 10.75 in x 14.75 in x 4.125 in
- Height Rod:**
24-84 in (60-212 cm)
- Height Division:**
0.125 in (0.1 cm)
- Warranty:**
Two-year limited warranty

Standard Features

- Sturdy, enameled steel body
- Painted beam
- Rugged scale understructure
- Durable wheels for easy transport
- Easy operation with two sliding weights
- Removable slip-resistant scale base cover
- Aluminum height rod measures from 24 to 84 in (60 to 212 cm)

Part Number/Price

Part #	Model #	Capacity	Price
102613	RL-MPS	440 lb x 4 oz (200 kg x 100 g)	\$345.00

Shipping Weight

Part #	Model #	L (in)	W (in)	H (in)	Package Wgt. (lb)	Dim Wgt. (lb)	Shipping Wgt. (lb)
102613	RL-MPS	60	21	7	42	64	64

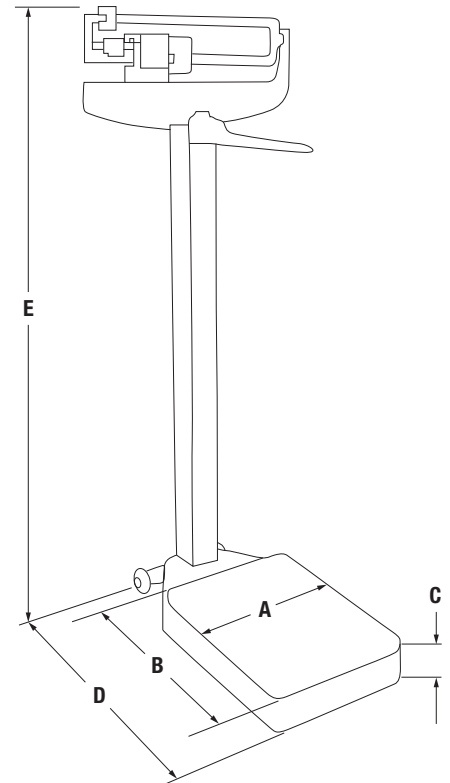

Dimensions

	Inches	Centimeters
A	10.8	27.4
B	14.8	37.6
C	4.1	10.4
D	22.3	56.6
E	58.5	148.6

RL-MPS-10

Mechanical Physician Scale

Specifications

Capacity:

450 lb x 4 oz

Platform Dimensions:

(W x L x H) 10.75 in x 14.75 in x 4.125 in

Height Rod:

24-84 in

Height Division:

0.125 in

Warranty:

Two-year limited warranty

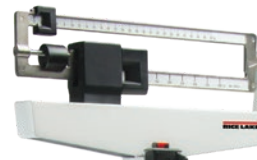

Model RL-MPS-10

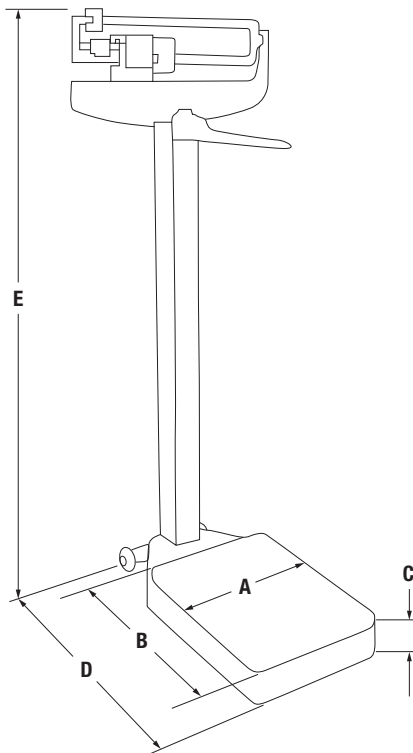

Standard Features

- Sturdy, enameled steel body
- Painted beam
- Rugged scale understructure
- Durable wheels for easy transport
- Easy operation with two sliding weights
- Removable slip-resistant scale base cover
- Aluminum height rod measures from 24 to 84 inches

Part Number/Price

Part #	Model #	Capacity	Price
124223	RL-MPS-10	450 lb x 4 oz	\$345.00

Shipping Weight

Part #	Model #	L (in)	W (in)	H (in)	Package Wgt. (lb)	Dim Wgt. (lb)	Shipping Wgt. (lb)
124223	RL-MPS-10	60	21	7	42	64	64

Dimensions

	Inches	Centimeters
A	10.8	27.4
B	14.8	37.6
C	4.1	10.4
D	22.3	56.6
E	58.5	148.6

RL-MPS-20

Mechanical Physician Scale



Model RL-MPS-20



Specifications

Capacity:

440 lb x 4 oz (200 kg x 100 g)

Platform Dimensions:

(W x L x H) 10.75 in x 14.75 in x 4.125 in

Warranty:

Two-year limited warranty

Standard Features

- Sturdy, enameled steel body
- Painted beam
- Rugged scale understructure
- Easy operation with two sliding weights
- Removable slip-resistant scale base cover

Part Number/Price

Part #	Model #	Capacity	Price
124222	RL-MPS-20	440 lb x 4 oz (200 kg x 100 g)	\$330.00

Shipping Weight

Part #	Model #	L (in)	W (in)	H (in)	Package Wgt. (lb)	Dim Wgt. (lb)	Shipping Wgt. (lb)
124222	RL-MPS-20	60	21	7	36	64	64

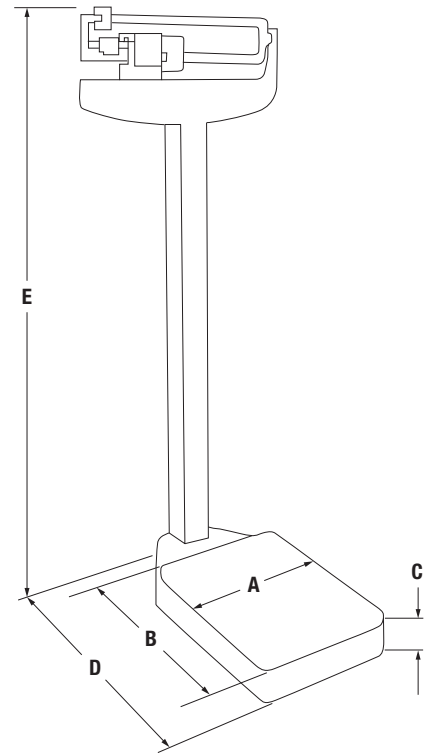

Dimensions

	Inches	Centimeters
A	10.8	27.4
B	14.8	37.6
C	4.1	10.4
D	22.3	56.6
E	58.5	148.6

RL-MPS-30

Mechanical Physician Scale

Specifications

Capacity:

180 kg x 100 g

Platform Dimensions:

(W x L x H) 27.5 cm x 37.5 cm x 10.5 cm

Height Rod:

60-212 cm

Height Division:

0.1 cm

Warranty:

Two-year limited warranty



Model RL-MPS-30

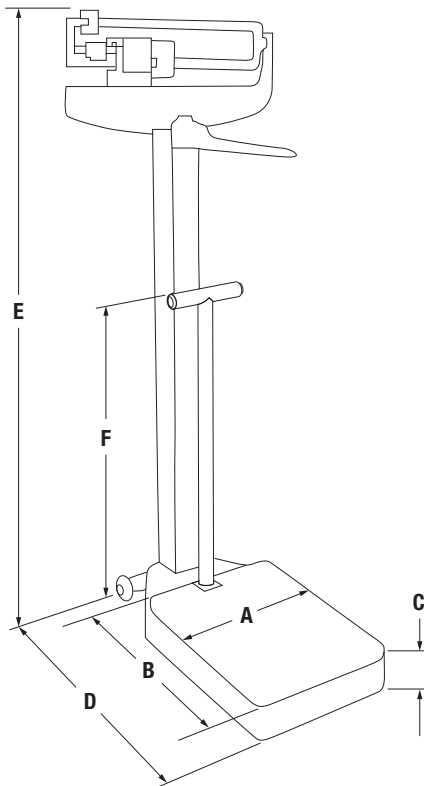

Dimensions

	Inches	Centimeters
A	10.8	27.4
B	14.8	37.6
C	4.1	10.4
D	22.3	56.6
E	58.5	148.6
F	31.5	80.0

Standard Features

- Sturdy, enameled steel body
- Painted beam
- Rugged scale understructure
- Handpost
- Durable wheels for easy transport
- Easy operation with two sliding weights
- Removable slip-resistant scale base cover
- Aluminum height rod measures from 60 cm to 212 cm

Part Number/Price

Part #	Model #	Capacity	Price
132703	RL-MPS-30	180 kg x 100 g	\$385.00

Shipping Weight

Part #	Model #	L (in)	W (in)	H (in)	Package Wgt. (lb)	Dim Wgt. (lb)	Shipping Wgt. (lb)
132703	RL-MPS-30	60	21	7	40	64	64

RL-MPS-40

Mechanical Physician Scale



Model RL-MPS-40



Specifications

Capacity with counterpoise weights:
490 lb x 4 oz (220 kg x 100 g)

Platform Dimensions:
(W x L x H) 10.75 in x 14.75 in x 4.125 in

Height Rod:
24-84 in (60-212 cm)

Height Division:
0.125 in (0.1 cm)

Warranty:
Two-year limited warranty

Standard Features

- Dual-read capacity and height rod
- Sturdy enameled steel body
- Painted beam designed to hold counterpoise weights
- Rugged scale understructure
- Removable slip-resistant plastic base cover
- Retractable aluminum height rod
- Easy operation with two sliding weights and two counterpoise weights
- Rear wheels for portability ease
- Aluminum height rod measures from 24 in to 84 in (60 cm to 212 cm)

Part Number/Price

Part #	Model #	Capacity	Price
185289	RL-MPS-40	490 lb x 4 oz (220 kg x 100 g)	\$375.00

Shipping Weight

Part #	Model #	L (in)	W (in)	H (in)	Package Wgt. (lb)	Dim Wgt. (lb)	Shipping Wgt. (lb)
185289	RL-MPS-40	60	21	7	44	64	64

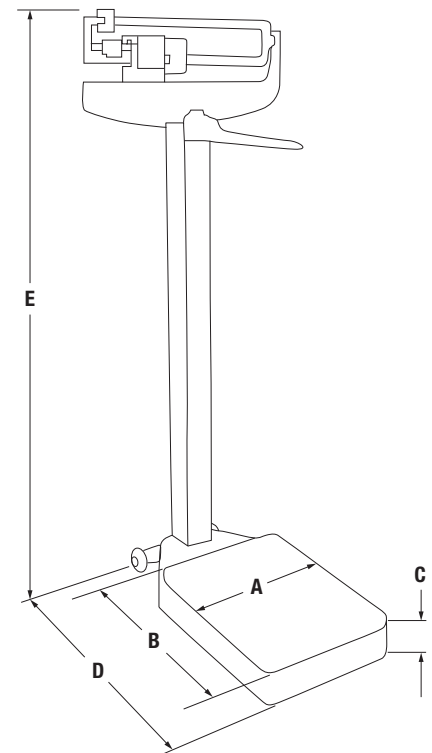

Dimensions

	Inches	Centimeters
A	10.8	27.4
B	14.8	37.6
C	4.1	10.4
D	22.3	56.6
E	58.5	148.6

RL-MPS-50

Mechanical Physician Scale

Specifications

- Capacity:**
450 lb x 4 oz (200 kg x 100 g)
- Platform Dimensions:**
(W x L x H) 11.02 in x 14.96 in x 4.21 in
- Height Rod:**
29.5-78.75 in (75-200 cm)
- Height Division:**
0.25 in (5 mm)
- Warranty:**
One-year limited warranty



Model RL-MPS-50

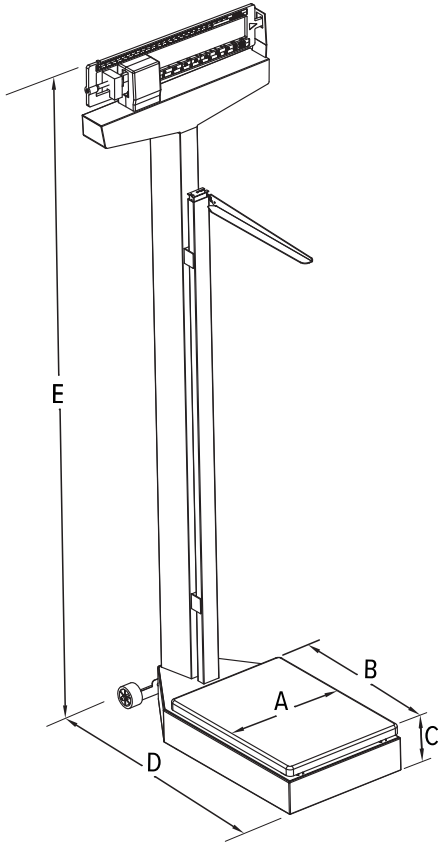

Standard Features

- Ease of transport with rear wheels
- Aluminum height rod included
- Poise travels free on weigh beam with simple finger tap
- Easy-to-read weigh beam's color-coded black inset shows LB markings, white inset shows KG markings. The beam can be rotated to the desired unit of measure.

Part Number/Price

Part #	Model #	Capacity	Price
195264	RL-MPS-50	450 lb x 4 oz (200 kg x 100 g)	\$345.00

Shipping Weight

Part #	Model #	L (in)	W (in)	H (in)	Package Wgt. (lb)	Dim Wgt. (lb)	Shipping Wgt. (lb)
195264	RL-MPS-50	60	21	5	39	46	46

Dimensions

	Inches	Centimeters
A	11.0	28.9
B	15.0	38.1
C	4.2	10.7
D	22.2	56.4
E	58.9	149.6



150-10-5

Digital Physician Scale



EYE-LEVEL

Specifications

Capacity:

550 lb x 0.2 lb (250 kg x 0.1 kg)

Platform Dimensions:

(W x L x H) 14.5 in x 14.5 in x 3 in

Power:

9 VDC, provided by six AA alkaline batteries (included) or AC adaptor (optional)

Battery Type:

Six AA alkaline (included)

Battery Use:

25 hours continuous use with batteries
Automatic power-off can be configured

Operating Temperature:

50° F to 104° F (10° C to 40° C)

Display:

5-digit LCD display, 0.75 in (1.9 cm) digit height

Approvals:

c-Met, E113986

Warranty:

Two-year limited warranty

Model 150-10-5

Standard Features

- Large, stable scale base
- Integrated height rod measures from 27.5 in to 82 in (70 cm to 208 cm)
- Rubber wheels for easy transport
- Push-button LCD display
- Unit of measure toggle or locking
- Motiontrap™ movement compensation technology
- EHR capable
- USB or Bluetooth® BLE 4.0 available, part number selectable
- Hold function
- Zero function
- BMI (body mass index) function
- Factory calibrated

APPROVALS



Part Number/Price

Part #	Model #	Capacity	Price
119113	150-10-5	550 lb x 0.2 lb (250 kg x 0.1 kg) with USB	\$630.00
194726	150-10-5BLE	550 lb x 0.2 lb (250 kg x 0.1 kg) with Bluetooth® BLE 4.0	\$865.00

Shipping Weight

Part #	Model #	L (in)	W (in)	H (in)	Package Wgt. (lb)	Dim Wgt. (lb)	Shipping Wgt. (lb)
119113	150-10-5	30	18	9	26	35	35
194726	150-10-5BLE	30	18	9	26	35	35

Options/Accessories

Part #	Description	Price
115655 †	9 VDC adaptor, 120 V/230 V auto switching c-MET medical grade power supply	\$43.00
133077 †	9 VDC adaptor, 120 V/230 V auto switching	\$25.00
102508 ††	9 VDC adaptor, 230 V	\$30.00
81076	Epson TM-U220 tape printer	\$445.00
186830	Printer cable, 25-pin D-Sub male to RJ-45, 6 ft	\$69.00



† NEMA 1-15 Plug



†† CEE 7/16 Plug

Dimensions

	Inches	Centimeters
A	54.0	137.2
B	22.4	57.0
C	14.7	37.5
D	3.0	7.6

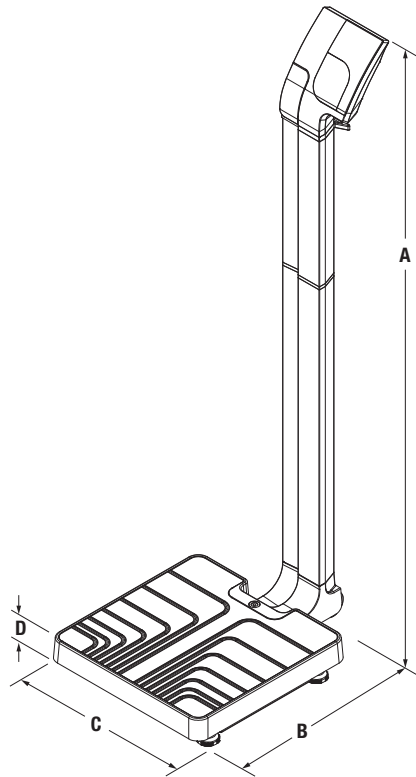

150-10-6

Digital Physician Scale



Specifications

- Capacity:**
550 lb x 0.2 lb (250 kg x 0.1 kg)
- Platform Dimensions:**
(W x L x H) 14.5 in x 14.5 in x 3 in
- Power:**
9 VDC, provided by six AA alkaline batteries (included) or AC adaptor (optional)
- Battery Type:**
Six AA alkaline (included)
- Battery Use:**
25 hours continuous use with batteries
Automatic power-off can be configured
- Operating Temperature:**
50° F to 104° F (10° C to 40° C)
- Display:**
5-digit LCD display, 0.75 in (1.9 cm) digit height
- Approvals:**
c-Met, E113986
- Warranty:**
Two-year limited warranty

Standard Features

- Large, stable scale base
- Rubber wheels for easy transport
- Push-button LCD display
- Unit of measure toggle or locking
- Motiontrap™ movement compensation technology
- EHR capable
- USB or Bluetooth® BLE 4.0 available, part number selectable
- Hold function
- Zero function
- BMI (body mass index) function
- Factory calibrated

APPROVALS



Part Number/Price

Part #	Model #	Capacity	Price
161786	150-10-6	550 lb x 0.2 lb (250 kg x 0.1kg) with USB	\$610.00
194732	150-10-6BLE	550 lb x 0.2 lb (250 x 0.1kg) with Bluetooth® BLE 4.0	\$845.00

Shipping Weight

Part #	Model #	L (in)	W (in)	H (in)	Package Wgt. (lb)	Dim Wgt. (lb)	Shipping Wgt. (lb)
161786	150-10-6	30	19	9	25	37	37
194732	150-10-6BLE	30	19	9	25	37	37

Options/Accessories

Part #	Description	Price
115655 †	9 VDC adaptor, 120 V/230 V auto switching c-MET medical grade power supply	\$43.00
133077 †	9 VDC adaptor, 120 V/230 V auto switching	\$25.00
102508 ††	9 VDC adaptor, 230 V	\$30.00
81076	Epson TM-U220 tape printer	\$445.00
186830	Printer cable, 25-pin D-Sub male to RJ-45, 6 ft	\$69.00



† NEMA 1-15 Plug



†† CEE 7/16 Plug

Dimensions

	Inches	Centimeters
A	48.4	123.0
B	22.4	57.0
C	14.7	37.5
D	3.0	7.6

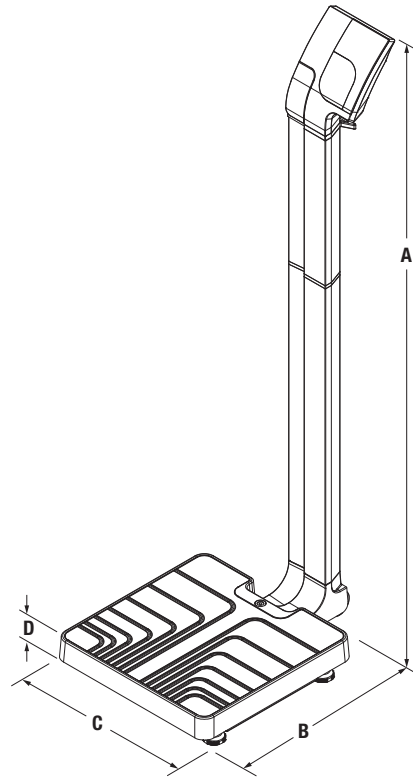

150-10-7

Digital Physician Scale



FLOOR-LEVEL

Model 150-10-7

Specifications

- Capacity:**
550 lb x 0.2 lb (250 kg x 0.1 kg)
- Platform Dimensions:**
(W x L x H) 14.5 in x 14.5 in x 3 in
- Power:**
9 VDC, provided by six AA alkaline batteries (included) or AC adaptor (optional)
- Battery Type:**
Six AA alkaline (included)
- Battery Use:**
25 hours continuous use with batteries
Automatic power-off can be configured
- Operating Temperature:**
50° F to 104° F (10° C to 40° C)
- Display:**
5-digit LCD display, 0.75 in (1.9 cm) digit height
- Approvals:**
c-Met, E113986
- Warranty:**
Two-year limited warranty

Standard Features

- Large, stable scale base
- Push-button LCD display
- Unit of measure toggle or locking
- Motiontrap™ movement compensation technology
- EHR capable
- USB or Bluetooth® BLE 4.0 available, part number selectable
- Hold function
- Zero function
- BMI (body mass index) function
- 6 ft cable between digital display and base
- Factory calibrated

APPROVALS



Part Number/Price

Part #	Model #	Capacity	Price
121304	150-10-7	550 lb x 0.2 lb (250 kg x 0.1kg) with USB	\$490.00
194728	150-10-7BLE	550 lb x 0.2 lb (250 kg x 0.1kg) with Bluetooth® BLE 4.0	\$725.00

Shipping Weight

Part #	Model #	L (in)	W (in)	H (in)	Package Wgt. (lb)	Dim Wgt. (lb)	Shipping Wgt. (lb)
121304	150-10-7	25	18	6	17	20	20
194728	150-10-7BLE	25	18	6	17	20	20

Options/Accessories

Part #	Description	Price
102508 ††	9 VDC adaptor, 230 V	\$30.00
107445	Carrying case	\$92.00
115655 †	9 VDC adaptor, 120 V/230 V auto switching c-MET medical grade power supply	\$43.00
133077 †	9 VDC adaptor, 120 V/230V auto switching	\$25.00
81076	Epson TM-U220 tape printer	\$445.00
186830	Printer cable, 25-pin D-Sub male to RJ-45, 6 ft	\$69.00



† NEMA 1-15 Plug



†† CEE 7/16 Plug

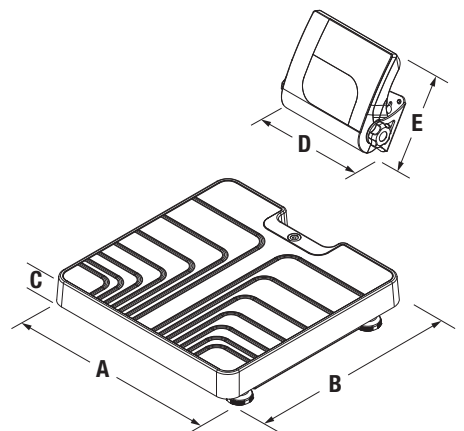

Dimensions

	Inches	Centimeters
A	14.7	37.5
B	14.7	37.5
C	3.0	7.6
D	7.8	20.0
E	6.7	17.0

160-10-7N

Digital Athletic Low-profile Scale

Specifications

Capacity:

550 lb x 0.2 lb (250 kg x 0.1 kg)

Platform Dimensions:

(W x L x H) 14.4 in x 14.4 in x 1.65 in

Power:

9 VDC, provided by six AA alkaline batteries (included) or 120V/230V AC adaptor, NEMA 1-15 plug (included)

Battery Type:

Six AA alkaline (included)

Battery Use:

25 hours continuous use with batteries
Automatic power-off can be configured

Operating Temperature:

50 °F to 104 °F (10 °C to 40 °C)

Display:

5-digit LCD display, 0.75 in (1.9 cm) digit height

Approvals:

c-Met, E113986
NTEP CC 18-011
Measurement Canada AM-6097

Warranty:

Two-year limited warranty



Standard Features

- Large, stable scale base
- Push-button LCD display
- Unit of measure toggle or locking
- Motiontrap™ movement compensation technology
- EHR capable
- 6 ft cable between digital display and base
- Zero function
- Factory calibrated

APPROVALS



Part Number/Price

Part #	Model #	Capacity	Price
193355	160-10-7N	550 lb x 0.2 lb (250 kg x 0.1 kg)	\$725.00

Shipping Weight

Part #	Model #	L (in)	W (in)	H (in)	Package Wgt. (lb)	Dim Wgt. (lb)	Shipping Wgt. (lb)
193355	160-10-7N	20	18	6	18	16	18

Options/Accessories

Part #	Description	Price
107445	Carrying case	\$92.00
81076	Epson TM-U220 tape printer	\$445.00
186830	Printer cable, 25-pin D-Sub male to RJ-45, 6 ft	\$69.00



† NEMA 1-15 Plug

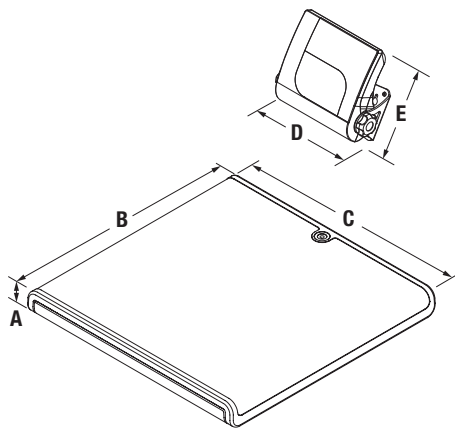

Dimensions

	Inches	Centimeters
A	1.7	4.3
B	14.4	36.6
C	14.4	36.6
D	7.8	20.0
E	6.7	17.0

RL-WMS-10

Wall Mount Stadiometer



Specifications

Measurement Range:

23 to 82 in (60 to 210 cm)

Height Divisions:

1/16 in (1 mm)

Warranty:

One-year limited warranty

Standard Features

- Aluminum construction
- Folding headpiece makes the product compact when not in use
- Measures both inches and centimeters
- Hardware included for mounting to metal, wood or drywall walls

Part Number/Price

Part #	Model #	Capacity	Price
Master Carton			
*195263	RL-WMS-10	23-82 x 1/16 in (60-120 cm x 1 mm)	\$980.00
Single Carton			
206553	RL-WMS-10	23-82 x 1/16 in (60-120 cm x 1 mm)	\$103.00

*10 Stadiometers per master carton

RL-MIS

Mechanical Baby Scale

Specifications

Capacity:

135 lb x 1 oz (62 kg x 20 g)

Tray Dimensions:

(W x L x H) 24 in x 16 in x 3 in
61 cm x 41 cm x 7.5 cm

Warranty:

Two-year limited warranty



Standard Features

- Painted beam
- Sturdy, enameled steel body
- Easy-to-clean ABS plastic tray
- Dual-read capacity; lb and kg
- Built-in measuring tape 0-23 in (0-58 cm)

Part Number/Price

Part #	Model #	Capacity	Price
131470	RL-MIS	135 lb x 1 oz (62 kg x 20 g)	\$370.00

Shipping Weight

Part #	Model #	L (in)	W (in)	H (in)	Package Wgt. (lb)	Dim Wgt. (lb)	Shipping Wgt. (lb)
131470	RL-MIS	28	20	14	30	57	57

RL-MIS-20

Mechanical Baby Scale



Specifications

Capacity:

70 kg x 20 g

Tray Dimensions:

(W x L x H) 61 cm x 41 cm x 7.5 cm

Warranty:

Two-year limited warranty

Standard Features

- Painted beam
- Sturdy, enameled steel body
- Easy-to-clean ABS plastic tray
- Unit of measure: kg
- Built-in measuring tape 0-58 cm

Part Number/Price

Part #	Model #	Capacity	Price
131471	RL-MIS-20	70 kg x 20 g	\$370.00

Shipping Weight

Part #	Model #	L (in)	W (in)	H (in)	Package Wgt. (lb)	Dim Wgt. (lb)	Shipping Wgt. (lb)
131471	RL-MIS-20	28	20	14	30	57	57

Digital Baby Scale - Suspended Infant Scale

Specifications

Capacity:

OS-10: 22 lb x 0.02 lb (22 lb x 0.25 oz)
 (10 kg x 0.01 kg)
 OS-25: 55 lb x 0.05 lb (55 lb x 0.5 oz)
 (25 kg x 0.02 kg)
 OS-45: 99 lb x 0.1 lb (99 lb x 1 oz)
 (45 kg x .05 kg)

Power:

Two AA batteries (included)

Operating Temperature:

32° F to 104° F (0° C to 40° C)

Warranty:

One-year limited warranty

Approvals:

CE Marked



Carrying case

Sturdy steel closed loop S-hook for safety

Model OS-10/25/45

Standard Features

- Hold function
- Units of measure kg/lb/lb-oz
- Adjustable automatic shut-off
- Ergonomic handheld design
- Carrying case and top s-hook included

APPROVALS



Part Number/Price

Part #	Model #	Capacity	Price
130292	OS-10	22 lb x 0.02 lb (22 lb x 0.25 oz) (10 kg x 0.01 kg)	\$90.00
130293	OS-25	55 lb x 0.05 lb (22 lb x 0.5 oz) (25 kg x 0.02 kg)	\$90.00
130294	OS-45	99 lb x 0.1 lb (22 lb x 1 oz) (45 kg x 0.05 kg)	\$90.00

Shipping Weight

Part #	Model #	L (in)	W (in)	H (in)	Package Wgt. (lb)	Dim Wgt. (lb)	Shipping Wgt. (lb)
130292	OS-10	10	5	3	2	2	2
130293	OS-25	10	5	3	2	2	2
130294	OS-45	10	5	3	2	2	2

Options/Accessories

Part #	Description	Price
141444	Suspended pediatric sling seat trousers	\$6.00

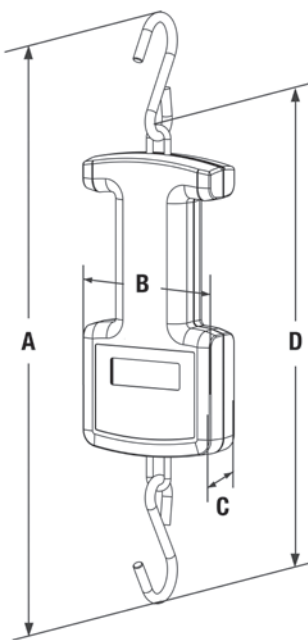

Dimensions

	Inches	Centimeters
A	14.3	36.3
B	3.6	9.2
C	1.3	3.2
D	11.6	29.4



Optional suspended pediatric sling trousers

RL-DBS

Digital Baby Scale



Model RL-DBS

Specifications

Capacity:

44 lb x 0.5 oz (20 kg x 10 g)

Power:

Four AA alkaline batteries (included) or AC adaptor (included)

Battery Type:

Four AA alkaline (included)

Approvals:

AC adaptor: cULus

Warranty:

Two-year limited warranty

Standard Features

- Large 1 in LCD display
- Unit of measure locking
- Recall function to view last weight
- Automatic shut-off for long battery life
- Built-in measuring tape 0-22.5 in (0-57 cm)
- Optional carrying case

Part Number/Price

Part #	Model #	Capacity	Price
107423	RL-DBS	44 lb x 0.5 oz (20 kg x 10 g), includes 120 VAC adaptor	\$152.00
112571	RL-DBS	44 lb x 0.5 oz (20 kg x 10 g), includes 230 VAC adaptor	\$152.00

Shipping Weight

Part #	Model #	L (in)	W (in)	H (in)	Package Wgt. (lb)	Dim Wgt. (lb)	Shipping Wgt. (lb)
107423	RL-DBS 120V	27	18	7	10	21	21
112571	RL-DBS 230V	27	18	7	10	21	21

Options/Accessories

Part #	Description	Price
112570	Carrying Case	\$56.00
158463	Growth Chart, Birth to 36 months, Boy, contains 100 sheets	\$26.00
158464	Growth Chart, Birth to 36 months, Girl, contains 100 sheets	\$25.00
158465	Growth Chart, 2-20 years Boy, contains 100 sheets	\$26.00
158466	Growth Chart, 2-20 years Girl, contains 100 sheets	\$26.00

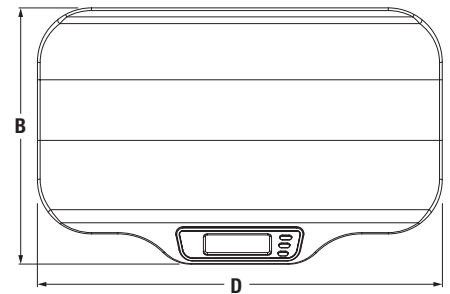
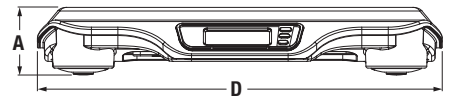
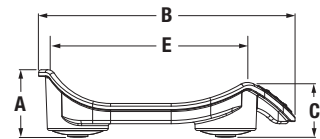

Optional Transport/Carrying Case

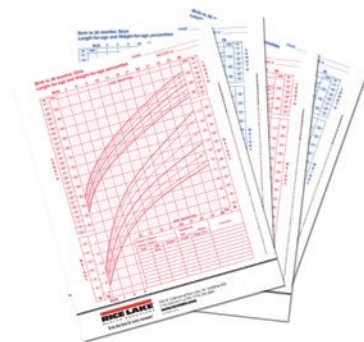

Optional Growth Charts

Dimensions

	Inches	Centimeters
A	3.9	10.0
B	15.0	38.0
C	3.1	7.9
D	23.6	60.0
E	11.0	27.9

RL-DBS-2

Digital Baby Scale

Specifications

Capacity:

0-22 lb x 0.2 oz (0-10 kg x 5 g)
22-44 lb x 0.5 oz (10-20 kg x 10 g)

Power:

Four AA alkaline batteries (included) or AC adaptor (included)

Battery Type:

Four AA alkaline (included)

Approvals:

AC adaptor: cULus

Warranty:

Two-year limited warranty

DUAL RANGE

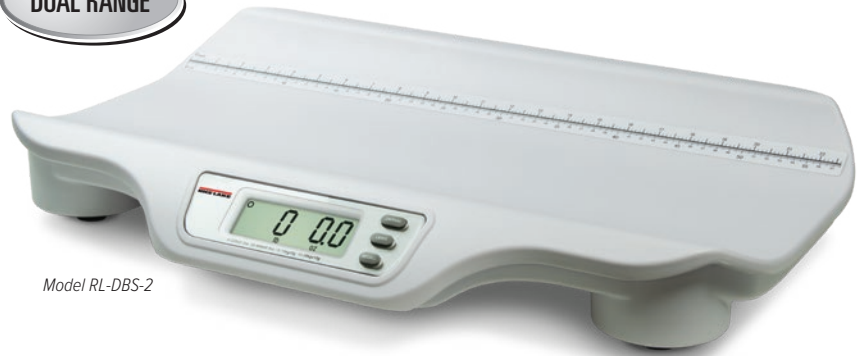

Standard Features

- Large 1 in LCD display
- Dual-range capacity for increased precision from 0-22 lb
- Accuracy within 5 grams
- Unit of measure locking
- Recall function to view last weight
- Automatic shut-off for long battery life
- Built-in measuring tape 0-22.5 in (0-57 cm)

Part Number/Price

Part #	Model #	Capacity	Price
155922	RL-DBS-2	0-22 lb x 0.2 oz, 22-44 lb x 0.5 oz (0-10 kg x 5 g, 10-20 kg x 10 g) includes 120 VAC adaptor	\$180.00
155923	RL-DBS-02	0-22 lb x 0.2 oz, 22-44 lb x 0.5 oz (0-10 kg x 5 g, 10-20 kg x 10 g) includes 230 VAC adaptor	\$180.00

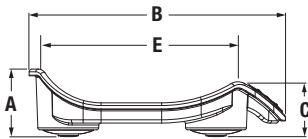

Shipping Weight

Part #	Model #	L (in)	W (in)	H (in)	Package Wgt. (lb)	Dim Wgt. (lb)	Shipping Wgt. (lb)
155922	RL-DBS-2 120V	28	18	6	10	22	22
155923	RL-DBS-2 230V	28	18	6	10	22	22

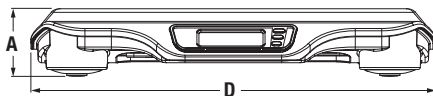

Options/Accessories

Part #	Description	Price
112570	Carrying Case	\$56.00
158463	Growth Chart, Birth to 36 months, Boy, contains 100 sheets	\$26.00
158464	Growth Chart, Birth to 36 months, Girl, contains 100 sheets	\$25.00
158465	Growth Chart, 2-20 years Boy, contains 100 sheets	\$26.00
158466	Growth Chart, 2-20 years Girl, contains 100 sheets	\$26.00

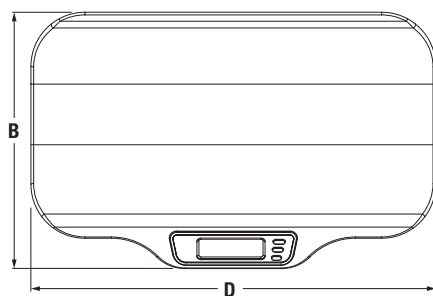

Dimensions

	Inches	Centimeters
A	3.9	10.0
B	15.0	38.0
C	3.1	7.9
D	23.6	60.0
E	11.0	27.9



Optional Growth Charts



Optional Transport/Carrying Case

D400

Adult and Child Scale



Model D400

Specifications

Capacity:

No tare entered:
 0-100 lb x 0.1 lb; 100-440 lb x 0.2 lb
 Tare entered: 0-100 lb x 2 oz; 100-400 lb x 4 oz
 Metric: 0-50 kg x 0.05 kg; 50-200 kg x 0.1 kg

Power:

Four AA alkaline batteries (included) and
 AC adaptor (included)

Battery Type:

Four AA alkaline (included)

Warranty:

One-year limited warranty

Standard Features

- Large, stable scale base
- LCD display
- Standard or Adult and Child weighing mode
- Tap to turn on
- Auto power-off ensures long battery life
- Master power switch to prevent power-on during transport
- Units of measure: lb, kg
- Scale capacity switches from pounds to ounces when tare function for adult weight is used
- Optional carrying case

Part Number/Price

Part #	Model #	Capacity	Price
157108	D400	440 lb (200 kg)	\$132.00

Shipping Weight

Part #	Model #	L (in)	W (in)	H (in)	Package Wgt. (lb)	Dim Wgt. (lb)	Shipping Wgt. (lb)
157108	D400	17	15	6	9	12	12

Options/Accessories

Part #	Description	Price
107445	Carrying case	\$92.00



Optional Transport/Carrying Case

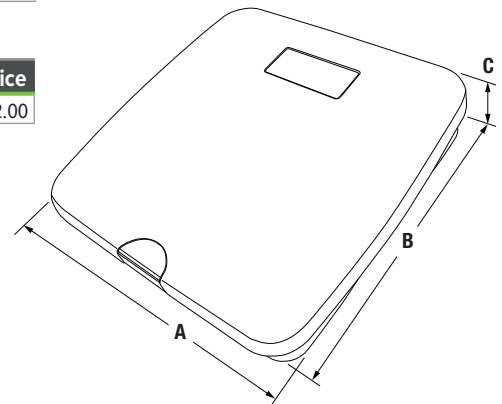

Dimensions

	Inches	Centimeters
A	12.7	32.2
B	12.7	32.2
C	2.0	5.0

Specifications

Capacity:

0-10 lb x 0.05 oz (0-5 kg x 1 g)
10-33 lb x 0.1 oz (5-15 kg x 2 g)

Power:

12 VDC, provided by six AA lithium batteries (included) or AC adaptor (optional)

Battery Type:

Six Li-FeS2 batteries

Operating Temperature:

50° F to 95° F (10° C to 35° C)

Display:

5-digit LCD display, 0.75 in (1.9 cm) digit height

Approvals:

c-Met E113986

Warranty:

Two-year limited warranty



Model 650-10-1

Standard Features

- Large, easy-to-read, 0.75 in LCD display
- Dual-range capacity for increased precision from 0-10 lb
- Unit of measure locking
- Automatic shut-off for long battery life
- Motiontrap™ movement compensation technology
- Built-in measuring tape 0-23.5 in x 0.125 in (0-60 cm x 0.25 cm)

APPROVALS



Part Number/Price

Part #	Model #	Capacity	Price
161784	650-10-1	0-10 lb x 0.05 oz, 10-33 lb x 0.1 oz (0-5 kg x 1g, 5-15 kg x 2 g) 120 V/230 V	\$970.00

Shipping Weight

Part #	Model #	L (in)	W (in)	H (in)	Package Wgt. (lb)	Dim Wgt. (lb)	Shipping Wgt. (lb)
161784	650-10-1	18	28	11	25	40	40

Options/Accessories

Part #	Description	Price
165138	AC adaptor, input voltage 100-240 V, c-Met, medical grade	\$55.00

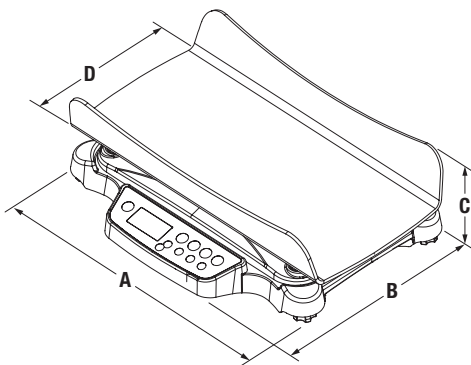

Dimensions

	Inches	Centimeters
A	24.0	60.8
B	19.0	48.2
C	6.75	17.1
D	17.0	43.2

RL-PMM

Pediatric Measuring Mat



Standard Features

- Graduations in inches and centimeters along both edges for easy viewing (PN 180124)
- Graduations in centimeters along both edges for easy viewing (PN 182999)
- Washable surface
- Fixed head positioner with sliding foot piece
- Soft, flexible, latex free material
- Head positioner and foot piece designed with rounded edges for safety
- Carry handle and lightweight design for easy portability

Part Number/Price

Part #	Model #	Capacity	Est. Weight	Price
180124	RL-PMM-10	4 in - 39 in (20 cm - 99 cm) measuring range 1/4 in (5 mm) graduation	2 lb	\$41.00
182999	RL-PMM-20	20 cm - 99 cm measuring range 5 mm graduation	2 lb	\$41.00

RL-PCT-10

Pediatric Circumference Tape



Standard Features

- Button to make tape retract around measurement surface for accurate body measurements
- Easy-to-read measurements, inches on one side centimeters on the other side
- Compact and portable

Part Number/Price

Part #	Model #	Measuring Range	Est. Weight	Price
186608	RL-PCT-10	0-205 cm x 1mm; 0-80 in x 1/8 in	1lb	\$6.00

260-10-1

Bariatric Handrail Scale

Specifications

Capacity:

800 lb x 0.2 lb (360 kg x 0.1 kg)

Platform Dimensions:

(W x L x H) 24 in x 24 in x 2.75 in

Height Rod Dimensions:

30-83.125 in (77-211 cm)

Power:

9 VDC, provided by six AA alkaline batteries (included) or AC adaptor (optional)

Battery Type:

Six AA alkaline (included)

Battery Use:

25 hours continuous use with batteries
Automatic power-off can be configured

Display:

5-digit LCD display, 0.75 in (1.9 cm) digit height

Operating Temperature:

50 °F to 104 °F (10 °C to 40 °C)

Warranty:

Two-year limited warranty



Model 260-10-1



Height rod can be mounted on either side

Shown with optional height rod

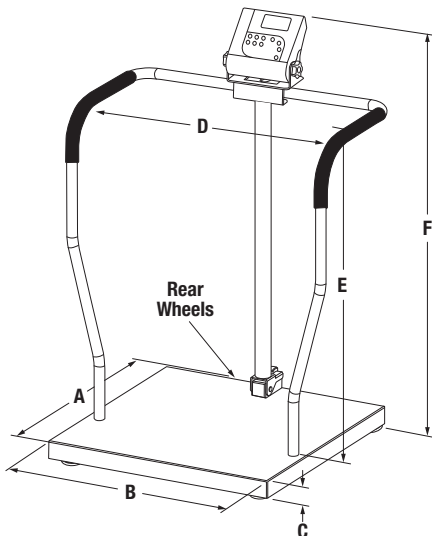

Standard Features

- Handrail for support and safety
- Two wheels for ease of portability
- Large 1 in LCD display
- Non-skid platform
- Unit of measure toggle or locking
- Motiontrap™ movement compensation technology
- EHR capable
- Tare function
- Hold function
- BMI (body mass index) function
- Factory calibrated
- Optional height rod can be installed on-site

Part Number/Price

Part #	Model #	Capacity	Price
170139	260-10-1	800 lb x 0.2 lb (360 kg x 0.1 kg) with USB	\$1,175.00

Shipping Weight

Part #	Model #	L (in)	W (in)	H (in)	Package Wgt. (lb)	Dim Wgt. (lb)	Shipping Wgt. (lb)
170139	260-10-1	40	40	10	58	116	116
172958	Height Rod	33	9	3	3	7	7

Options/Accessories

Part #	Description	Price
133077 †	9 VDC adaptor, 120 V/230 V auto switching	\$25.00
102508 ††	9 VDC adaptor, 230 V	\$30.00
172958	Height rod 30-83 in (77-210 cm)	\$75.00
81076	Epson TM-U220 tape printer	\$445.00
186830	Printer cable, 25-pin D-Sub male to RJ-45, 6 ft	\$69.00



† NEMA 1-15 Plug

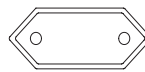

†† CEE 7/16 Plug

Dimensions

	Inches	Centimeters		Inches	Centimeters
A	24.0	61.0	D	25.5	65.0
B	24.0	61.0	E	33.5	85.0
C	2.75	7.0	F	43.0	109.0

250-10-2

Bariatric Handrail Scale



Model 250-10-2

Specifications

Capacity:

1,000 lb x 0.2 lb (450 kg x 0.1 kg)

Platform Dimensions:

(W x L x H) 20 in x 25 in x 3 in

Power:

9 VDC, provided by six AA alkaline batteries (included) or AC adaptor (optional)

Battery Type:

Six AA alkaline (included)

Battery Use:

25 hours continuous use with batteries
Automatic power-off can be configured

Operating Temperature:

50° F to 104° F (10° C to 40° C)

Display:

5-digit LCD display, 0.75 in (1.9 cm) digit height

Approvals:

c-Met, E113986

Warranty:

Two-year limited warranty

Standard Features

- Handrail for support and safety
- Two wheels for ease of portability
- Large 1 in LCD display
- Non-skid platform
- Unit of measure toggle or locking
- Motiontrap™ movement compensation technology
- EHR capable
- USB or Bluetooth® BLE 4.0 available, part number selectable
- Tare function
- Hold function
- BMI (body mass index) function
- Factory calibrated

APPROVALS

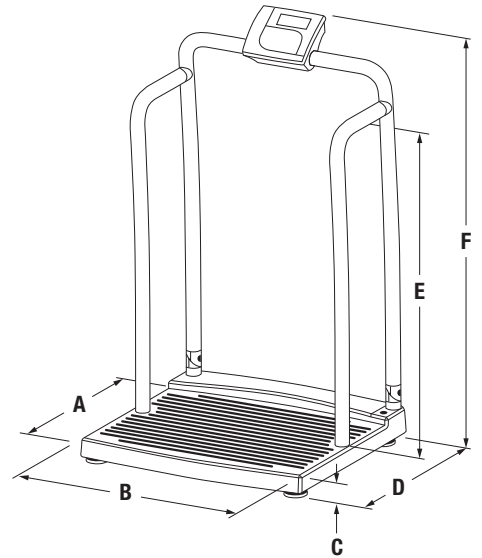

Dimensions

	Inches	Centimeters
A	20.0	50.8
B	25.0	63.5
C	3.0	7.6
D	25.0	63.5
E	34.0	86.4
F	44.5	113.0

Part Number/Price

Part #	Model #	Capacity	Price
133119	250-10-2	1,000 lb x 0.2 lb (450 kg x 0.1kg) with USB	\$1,285.00
194733	250-10-2BLE	1,000 lb x 0.2 lb (450 kg x 0.1kg) Bluetooth® BLE 4.0	\$1,520.00

Shipping Weight

Part #	Model #	L (in)	W (in)	H (in)	Package Wgt. (lb)	Dim Wgt. (lb)	Shipping Wgt. (lb)
133119	250-10-2	45	29	9	66	85	85
194733	250-10-2BLE	45	29	9	66	85	85

Options/Accessories

Part #	Description	Price
115655 †	9 VDC adaptor, 120 V/230 V auto switching c-MET medical grade power supply	\$43.00
133077 †	9 VDC adaptor, 120 V/230 V auto switching	\$25.00
102508 ††	9 VDC adaptor, 230 V	\$30.00
81076	Epson TM-U220 tape printer	\$445.00
186830	Printer cable, 25-pin D-Sub male to RJ-45, 6 ft	\$69.00



† NEMA 1-15 Plug

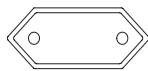

†† CEE 7/16 Plug

250-10-4

Bariatric Handrail Scale

Specifications

Capacity:

1,000 lb x 0.2 lb (450 kg x 0.1 kg)

Platform Dimensions:

(W x L x H) 20 in x 25 in x 3 in

Power:

9 VDC, provided by six AA alkaline batteries (included) or AC adaptor (optional)

Battery Type:

Six AA alkaline (included)

Battery Use:

25 hours continuous use with batteries
Automatic power-off can be configured

Operating Temperature:

50° F to 104° F (10° C to 40° C)

Display:

5-digit LCD display, 0.75 in (1.9 cm) digit height

Approvals:

c-Met, E113986

Warranty:

Two-year limited warranty



Model 250-10-4

Standard Features

- Handrail for support and safety
- Folding seat
- Two wheels for ease of portability
- Large 1 in LCD display
- Non-skid platform
- Unit of measure toggle or locking
- Motiontrap™ movement compensation technology
- EHR capable
- USB or Bluetooth® BLE 4.0 available, part number selectable
- Tare function
- Hold function
- BMI (body mass index) function
- Factory calibrated

APPROVALS

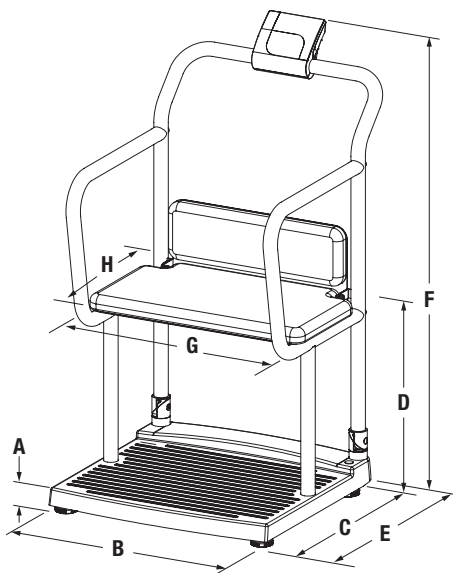

Dimensions

	Inches	Centimeters
A	2.8	7.0
B	25.7	65.3
C	25.2	64.0
D	21.6	54.9
E	32.0	81.1
F	47.5	120.7
G	20.0	50.8
H	12.0	30.5

Part Number/Price

Part #	Model #	Capacity	Price
133120	250-10-4	1,000 lb x 0.2 lb (450 kg x 0.1 kg) with USB	\$2,030.00
194734	250-10-4BLE	1,000 lb x 0.2 lb (450 kg x 0.1 kg) Bluetooth® BLE 4.0	\$2,265.00

Shipping Weight

Part #	Model #	L (in)	W (in)	H (in)	Package Wgt. (lb)	Dim Wgt. (lb)	Shipping Wgt. (lb)
133120	250-10-4	32	27	46	70	286	286
194734	250-10-4BLE	32	27	46	70	286	286

Options/Accessories

Part #	Description	Price
115655 †	9 VDC adaptor, 120 V/230 V auto switching c-MET medical grade power supply	\$43.00
133077 †	9 VDC adaptor, 120 V/230 V auto switching	\$25.00
102508 ††	9 VDC adaptor, 230 V	\$30.00
81076	Epson TM-U220 tape printer	\$445.00
186830	Printer cable, 25-pin D-Sub male to RJ-45, 6 ft	\$69.00



† NEMA 1-15 Plug

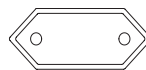

†† CEE 7/16 Plug

RL-MCS

Rice Lake Mechanical Chair Scale



16 INCH WIDE SEAT

Specifications

Capacity:

lb only beam 450 lb x 4 oz
kg only beam 200 kg x 100 g

Warranty:

Two-year limited warranty

Standard Features

- Capacity: lb only beam 450 lb x 4 oz; kg only beam 200 kg x 100 g
- Swing-up arms for easy access and exit
- Fold-up footrest
- Sturdy enameled, steel frame
- Dual read die cast beam
- Polypropylene seat with ABS armrest
- Heavy duty wheels - two back wheels lock, two front wheels swivel

Part Number/Price

Part #	Model #	Capacity	Price
172098	RL-MCS-LB	450 lb x 4 oz	\$660.00
172099	RL-MCS-KG	200 kg x 100 g	\$660.00

Shipping Weight

Part #	Model #	L (in)	W (in)	H (in)	Package Wgt. (lb)	Dim Wgt. (lb)	Shipping Wgt. (lb)
172098	RL-MCS-LB	29	25	25	79	131	131
172099	RL-MCS-KG	29	25	25	79	131	131



Model RL-MCS-LB

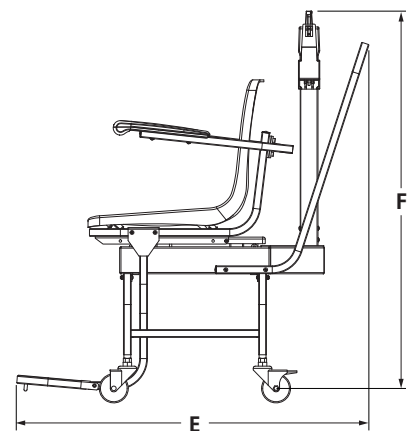
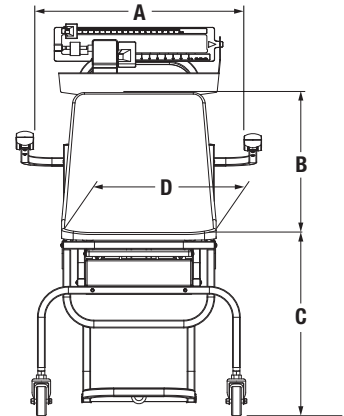

Dimensions

	Inches	Centimeters
A	21.5	54.6
B	14.2	36.1
C	14.8	37.6
D	16.0	40.6
E	35.7	90.7
F	38.4	97.5

560-10-1

Digital Chair Scale

Specifications

Capacity:

660 lb x 0.2 lb (300 kg x 0.1 kg)

Display:

5-digit LCD display, 0.75 in (1.9 cm) digit height

Power:

9 VDC provided by six AA alkaline batteries (included) or 120 V/230 VAC adaptor (optional)

Battery Type:

Six AA alkaline (included)

Battery Use:

25 hours continuous use with batteries
Automatic power-off can be configured

Warranty:

Two-year limited warranty

20 INCH WIDE SEAT



Model 560-10-1

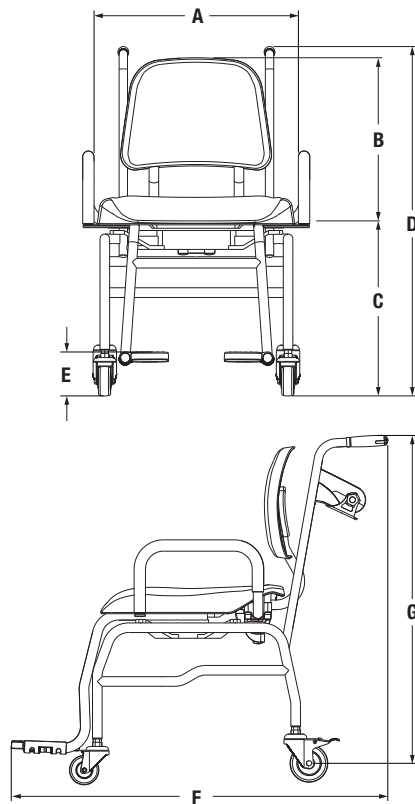

Dimensions

	Inches	Centimeters
A	20.1	51.1
B	17.3	44.0
C	20.1	51.1
D	36.4	92.5
E	5.9	15.0
F	42.9	109.0
G	34.6	88.0

Standard Features

- Enameled tubular steel frame
- Four heavy-duty caster wheels (rear wheels locking)
- Swing-up arms
- Side-folding footrests
- Molded seat
- Large 1 in LCD display
- Unit of measure toggle or locking
- Motiontrap™ movement compensation technology
- EHR capable
- Tare function
- Hold function
- BMI (body mass index) function
- Factory calibrated

Part Number/Price

Part #	Model #	Capacity	Price
166644	560-10-1	660 lb x 0.2 lb (300 kg x 0.1 kg)	\$1,175.00

Shipping Weight

Part #	Model #	L (in)	W (in)	H (in)	Package Wgt. (lb)	Dim Wgt. (lb)	Shipping Wgt. (lb)
166644	560-10-1	33	23	27	65	148	148

Options/Accessories

Part #	Description	Price
133077 †	9 VDC adaptor, 120 V/230 V auto switching	\$25.00
102508 ††	9 VDC adaptor, 230 V	\$30.00
81076	Epson TM-U220 tape printer	\$445.00
186830	Printer cable, 25-pin D-Sub male to RJ-45, 6 ft	\$69.00



† NEMA 1-15 Plug



†† CEE 7/16 Plug

550-10-1

Digital Chair Scale



Model 550-10-1

17 INCH WIDE SEAT

Specifications

Capacity:

660 lb x 0.2 lb (300 kg x 0.1 kg)

Power:

9 VDC provided by six AA alkaline batteries (included) or 120 V/230 VAC adaptor (optional)

Battery Type:

Six AA alkaline (included)

Battery Use:

25 hours continuous use with batteries
Automatic power-off can be configured

Display:

5-digit LCD display, 0.75 in (1.9 cm) digit height

Operating Temperature:

50° F to 104° F (10° C to 40° C)

Approvals:

c-Met, E113986

Warranty:

Two-year limited warranty

Standard Features

- Enameled tubular steel frame
- Four heavy-duty locking caster wheels
- Swing-up arms
- Flip-up footrest
- Large 1 in LCD display
- Unit of measure toggle or locking
- Motiontrap™ movement compensation technology
- EHR capable
- USB or Bluetooth® BLE 4.0 available, part number selectable
- Tare function
- Hold function
- BMI (body mass index) function
- Factory calibrated

APPROVALS

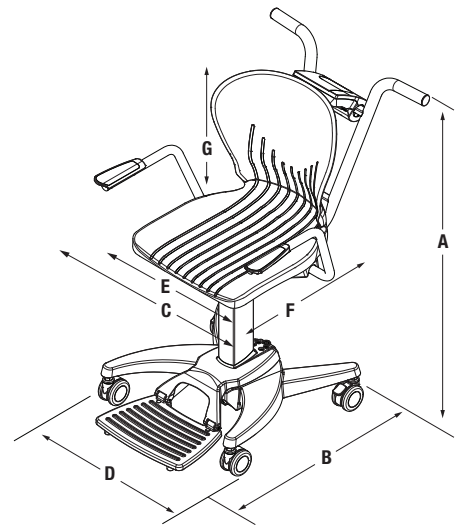

Dimensions

	Inches	Centimeters
A	37.4	95.0
B	33.4	85.0
C	25.2	64.0
D	20.5	52.0
E	17.0	43.2
F	16.0	40.6
G	17.0	43.2

Part Number/Price

Part #	Model #	Capacity	Price
119114	550-10-1	660 lb x 0.2 lb (300 kg x 0.1 kg) with USB	\$1,125.00
194740	550-10-1BLE	660 lb x 0.2 lb (300 kg x 0.1 kg) with Bluetooth® BLE 4.0	\$1,360.00

Shipping Weight

Part #	Model #	L (in)	W (in)	H (in)	Package Wgt. (lb)	Dim Wgt. (lb)	Shipping Wgt. (lb)
119114	550-10-1	29	27	29	54	164	164
194740	550-10-1BLE	29	27	29	54	164	164

Options/Accessories

Part #	Description	Price
115655 †	9 VDC adaptor, 120 V/230 V auto switching c-MET medical grade power supply	\$43.00
133077 †	9 VDC adaptor, 120 V/230 V auto switching	\$25.00
102508 ††	9 VDC adaptor, 230 V	\$30.00
81076	Epson TM-U220 tape printer	\$445.00
186830	Printer cable, 25-pin D-Sub male to RJ-45, 6 ft	\$69.00



† NEMA 1-15 Plug

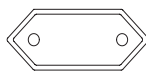

†† OEE 7/16 Plug

D300 Series

Wireless Wheelchair Scale

Specifications

Capacity:

D300-8: 800 lb x 0.5 lb (363 kg x 0.2 kg)

Power:

Wheel pads: Eight EL-123 batteries per scale system (two per pad) (included)
Controller: Three AAA lithium batteries (included)

Operating Temperature:

50° F to 90° F (10° C to 32° C)

Warranty:

Two-year limited warranty



Model D300



Optional transport/carrying case



Wheelchair positioned on pads

Standard Features

- Four lightweight, wireless scale pads
- Powder-coated molded plastic and cast aluminum construction
- Four wheel-stops and roll-up ramps
- Handheld controller
- Rubber controller glove and lanyard
- Optional carrying case

Part Number/Price

Part #	Model #	Capacity	Price
157141	D300-8	800 lb x 0.5 lb (363 kg x 0.2 kg)	\$2,832.00

Shipping Weight

Part #	Model #	L (in)	W (in)	H (in)	Package Wgt. (lb)	Dim Wgt. (lb)	Shipping Wgt. (lb)
157141	D300-8	17	13	13	15	21	21

Options/Accessories

Part #	Description	Price
107445	Carrying Case	\$92.00



350-10-3M

Dual-ramp Wheelchair Scale



Model 350-10-3M



Specifications

Capacity:

1,000 lb x 0.2 lb (450 kg x 0.1 kg)

Platform Dimensions:

(W x L x H) 31.5 in x 29.5 in x 3.15 in

Power:

9 VDC, provided by six AA alkaline batteries (included) or AC adaptor (optional)

Battery Type:

Six AA alkaline (included)

Battery Use:

25 hours continuous use with batteries
Automatic power-off can be configured

Operating Temperature:

50° F to 104° F (10° C to 40° C)

Display:

5-digit LCD display, 0.75 in (1.9 cm) digit height

Approvals:

c-Met, E113986

Warranty:

Two-year limited warranty

Standard Features

- Two wheels for portability
- Dual ramp
- Non-slip platform
- Large 1 in LCD display
- Motiontrap™ movement compensation technology
- Unit of measure toggle or locking
- EHR capable
- USB or Bluetooth® BLE 4.0 available, part number selectable
- Tare function
- Hold function
- BMI (body mass index) function
- Factory calibrated
- Easy to store, folded depth is 11.75 in

APPROVALS



Wheelchair scale in folded position

Part Number/Price

Part #	Model #	Capacity	Price
193956	350-10-3M	1,000 lb x 0.2 lb (450 kg x 0.1 kg) with USB	\$2,165.00
203910	350-10-3MBLE	1,000 lb x 0.2 lb (450 kg x 0.1 kg) with Bluetooth® BLE 4.0	\$2,400.00

Shipping Weight

Part #	Model #	L (in)	W (in)	H (in)	Package Wgt. (lb)	Dim Wgt. (lb)	Shipping Wgt. (lb)
193956	350-10-3M	51	42	14	102	216	216
203910	350-10-3MBLE	51	42	14	102	216	216

Options/Accessories

Part #	Description	Price
115655 †	9 VDC adaptor, 120 V/230 V auto switching c-MET medical grade power supply	\$43.00
133077 †	9 VDC adaptor, 120 V/230 V auto switching	\$25.00
102508 ††	9 VDC adaptor, 230 V	\$30.00
81076	Epson TM-U220 tape printer	\$445.00
186830	Printer cable, 25-pin D-Sub male to RJ-45, 6 ft	\$69.00



† NEMA 1-15 Plug

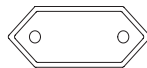

†† CEE 7/16 Plug

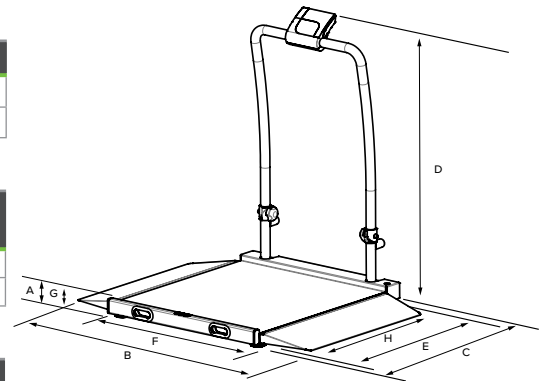

Dimensions

	Inches	Centimeters
A	3.15	8.0
B	47.7	121.2
C	37.8	96.0
D	45.3	115.1
E	31.5	80.0
F	29.5	74.9
G	2.4	6.1
H	27.2	69.1

Specifications

Capacity:

1,000 lb x 0.2 lb (450 kg x 0.1 kg)

Platform Dimensions Without Ramps:

(W x L x H) 32 in x 29.5 in x 2.375 in

Power:

9 VDC, provided by six AA alkaline batteries (included) or AC adaptor (optional)

Battery Type:

Six AA alkaline (included)

Battery Use:

25 hours continuous use with batteries
Automatic power-off can be configured

Operating Temperature:

50° F to 104° F (10° C to 40° C)

Display:

5-digit LCD display, 0.75 in (1.9 cm) digit height

Approvals:

c-Met, E113986

Warranty:

Two-year limited warranty



Model 350-10-2

Standard Features

- Two wheels for portability
- Single ramp
- Non-slip platform
- Large 1 in LCD display
- Motiontrap™ movement compensation technology
- Unit of measure toggle or locking
- EHR capable
- USB or Bluetooth® BLE 4.0 available, part number selectable
- Tare function
- Hold function
- BMI (body mass index) function
- Factory calibrated
- Easy to store, folded depth is 11.75 in

APPROVALS



Wheelchair scale in folded position

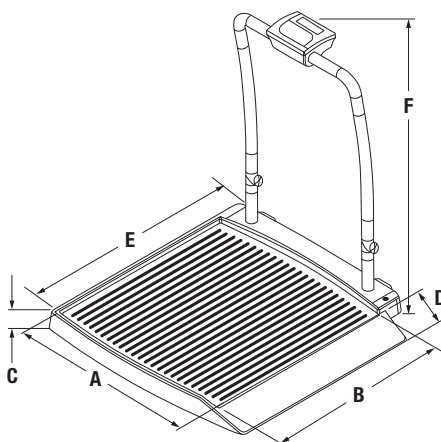

Dimensions

	Inches	Centimeters
A	29.5	74.9
B	32.0	81.3
C	2.4	6.1
D	9.3	23.5
E	37.5	95.3
F	45.0	114.3

Part Number/Price

Part #	Model #	Capacity	Price
141445	350-10-2	1,000 lb x 0.2 lb (450 kg x 0.1 kg) with USB	\$1,285.00
194739	350-10-2BLE	1,000 lb x 0.2 lb (450 kg x 0.1 kg) with Bluetooth® BLE 4.0	\$1,520.00

Shipping Weight

Part #	Model #	L (in)	W (in)	H (in)	Package Wgt. (lb)	Dim Wgt. (lb)	Shipping Wgt. (lb)
141445	350-10-2	42	41	14	90	174	174
194739	350-10-2BLE	42	41	14	90	174	174

Options/Accessories

Part #	Description	Price
115655 †	9 VDC adaptor, 120 V/230 V auto switching c-MET medical grade power supply	\$43.00
133077 †	9 VDC adaptor, 120 V/230 V auto switching	\$25.00
102508 ††	9 VDC adaptor, 230 V	\$30.00
81076	Epson TM-U220 tape printer	\$445.00
186830	Printer cable, 25-pin D-Sub male to RJ-45, 6 ft	\$69.00



† NEMA 1-15 Plug



†† CEE 7/16 Plug

350-10-7

Single-ramp Wheelchair Platform Scale



Model 350-10-7

Specifications

Capacity:

1,000 lb x 0.2 lb (450 kg x 0.1 kg)

Platform Dimensions Without Ramps:

(W x L x H) 32 in x 29.5 in x 2.375 in

Power:

9 VDC, provided by six AA alkaline batteries (included) or AC adaptor (optional)

Battery Type:

Six AA alkaline (included)

Battery Use:

25 hours continuous use with batteries
Automatic power-off can be configured

Operating Temperature:

50° F to 104° F (10° C to 40° C)

Display:

5-digit LCD display, 0.75 in (1.9 cm) digit height

Approvals:

c-Met, E113986

Warranty:

Two-year limited warranty

Standard Features

- Two wheels for portability
- Single ramp
- Non-slip platform
- Large 1 in LCD display
- Motiontrap™ movement compensation technology
- Unit of measure toggle or locking
- EHR capable
- USB or Bluetooth® BLE 4.0 available, part number selectable
- Tare function
- Hold function
- BMI (body mass index) function
- Factory calibrated

APPROVALS



Part Number/Price

Part #	Model #	Capacity	Price
141446	350-10-7	1,000 x 0.2 lb (450 x 0.1 kg) with USB	\$1,225.00
194738	350-10-7BLE	1,000 x 0.2 lb (450 x 0.1 kg) with Bluetooth® BLE 4.0	\$1,460.00

Shipping Weight

Part #	Model #	L (in)	W (in)	H (in)	Package Wgt. (lb)	Dim Wgt. (lb)	Shipping Wgt. (lb)
141446	350-10-7	45	44	7	78	100	100
194738	350-10-7BLE	45	44	7	78	100	100

Options/Accessories

Part #	Description	Price
115655 †	9 VDC adaptor, 120 V/230 V auto switching c-MET medical grade power supply	\$43.00
133077 †	9 VDC adaptor, 120 V/230 V auto switching	\$25.00
102508 ††	9 VDC adaptor, 230 V	\$30.00
81076	Epson TM-U220 tape printer	\$445.00
186830	Printer cable, 25-pin D-Sub male to RJ-45, 6 ft	\$69.00



† NEMA 1-15 Plug

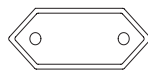

†† CEE 7/16 Plug

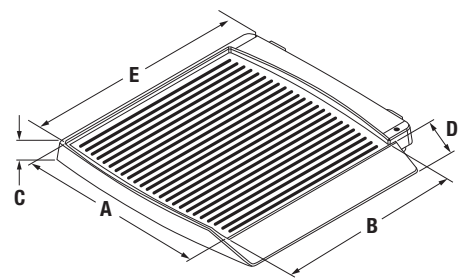

Dimensions

	Inches	Centimeters
A	29.5	74.9
B	32.0	81.3
C	2.4	6.1
D	9.3	23.5
E	37.5	95.3

350-10-3

Dual-ramp Wheelchair Scale

Specifications

Capacity:

1,000 lb x 0.2 lb (450 kg x 0.1 kg)

Platform Dimensions:

(W x L x H) 32 in x 29.5 in x 2.375 in

Power:

9 VDC, provided by six AA alkaline batteries (included) or AC adaptor (optional)

Battery Type:

Six AA alkaline (included)

Battery Use:

25 hours continuous use with batteries
Automatic power-off can be configured

Operating Temperature:

50° F to 104° F (10° C to 40° C)

Display:

5-digit LCD display, 0.75 in (1.9 cm) digit height

Approvals:

c-Met, E113986

Warranty:

Two-year limited warranty



Model 350-10-3



Wheelchair scale in folded position

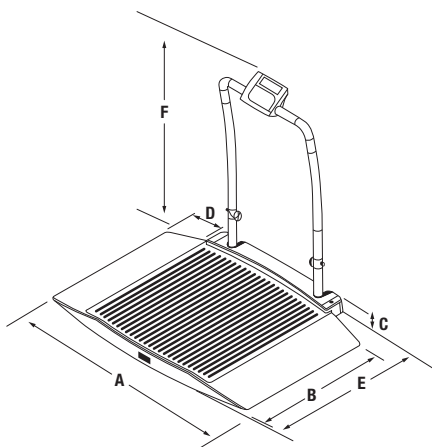

Dimensions

	Inches	Centimeters
A	48.5	123.2
B	32.0	81.3
C	2.4	6.1
D	9.3	23.6
E	38.0	96.5
F	45.0	114.3

Standard Features

- Two wheels for portability
- Dual ramp
- Non-slip platform
- Large 1 in LCD display
- Motiontrap™ movement compensation technology
- Unit of measure toggle or locking
- EHR capable
- USB or Bluetooth® BLE 4.0 available, part number selectable
- Tare function
- Hold function
- BMI (body mass index) function
- Factory calibrated
- Easy to store, folded depth is 11.75 in

APPROVALS



Part Number/Price

Part #	Model #	Capacity	Price
141447	350-10-3	1,000 lb x 0.2 lb (450 kg x 0.1 kg) with USB	\$1,970.00
194736	350-10-3BLE	1,000 lb x 0.2 lb (450 kg x 0.1 kg) with Bluetooth® BLE 4.0	\$2,205.00

Shipping Weight

Part #	Model #	L (in)	W (in)	H (in)	Package Wgt. (lb)	Dim Wgt. (lb)	Shipping Wgt. (lb)
141447	350-10-3	51	42	14	102	216	216
194736	350-10-3BLE	51	42	14	102	216	216

Options/Accessories

Part #	Description	Price
115655 †	9 VDC adaptor, 120 V/230 V auto switching c-MET medical grade power supply	\$43.00
133077 †	9 VDC adaptor, 120 V/230 V auto switching	\$25.00
102508 ††	9 VDC adaptor, 230 V	\$30.00
81076	Epson TM-U220 tape printer	\$445.00
186830	Printer cable, 25-pin D-Sub male to RJ-45, 6 ft	\$69.00



† NEMA 1-15 Plug



†† CEE 7/16 Plug

350-10-4

Dual-ramp Wheelchair Scale



Specifications

- Capacity:**
1,000 lb x 0.2 lb (450 kg x 0.1 kg)
- Platform Dimensions:**
(W x L x H) 32 in x 29.5 in x 2.375 in
- Chair Dimensions:**
(W x D) 12 in x 6.25 in
- Display:**
5-digit LCD display, 0.75 in (1.9 cm) digit height
- Power:**
9 VDC, provided by six AA alkaline batteries (included) or AC adaptor (optional)
- Battery Type:**
Six AA alkaline (included)
- Battery Use:**
25 hours continuous use with batteries
Automatic power-off can be configured
- Operating Temperature:**
50° F to 104° F (10° C to 40° C)
- Approvals:**
c-Met, E113986
- Warranty:**
Two-year limited warranty

Standard Features

- Two wheels for portability
- Dual ramp
- Non-slip platform
- Fold-away padded seat with backrest
- Large 1 in LCD display
- Motiontrap™ movement compensation technology
- Unit of measure toggle or locking
- EHR capable
- USB or Bluetooth® BLE 4.0 available, part number selectable
- Tare function
- Hold function
- BMI (body mass index) function
- Factory calibrated
- Easy to store, folded depth is 11.75 in

APPROVALS



Part Number/Price

Part #	Model #	Capacity	Price
141448	350-10-4	1,000 lb x 0.2 lb (450 kg x 0.1 kg) with USB	\$2,830.00
194737	350-10-4BLE	1,000 lb x 0.2 lb (450 kg x 0.1 kg) with Bluetooth® BLE 4.0	\$3,065.00

Shipping Weight

Part #	Model #	L (in)	W (in)	H (in)	Package Wgt. (lb)	Dim Wgt. (lb)	Shipping Wgt. (lb)
141448	350-10-4	51	43	21	132	332	332
194737	350-10-4BLE	51	43	21	132	332	332

Options/Accessories

Part #	Description	Price
115655 †	9 VDC adaptor, 120 V/230 V auto switching c-MET medical grade power supply	\$43.00
133077 †	9 VDC adaptor, 120 V/230 V auto switching	\$25.00
102508 ††	9 VDC adaptor, 230 V	\$30.00
81076	Epson TM-U220 tape printer	\$445.00
186830	Printer cable, 25-pin D-Sub male to RJ-45, 6 ft	\$69.00



† NEMA 1-15 Plug

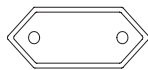

†† CEE 7/16 Plug

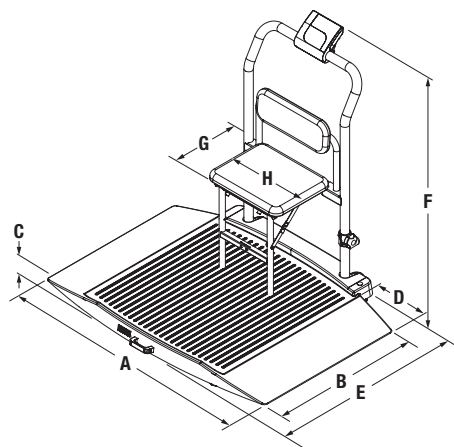

Dimensions

	Inches	Centimeters
A	48.5	123.2
B	32.0	81.3
C	2.4	6.1
D	9.3	23.6
E	38.0	96.5
F	45.0	114.3
G	6.3	16.0
H	12.0	30.5

Specifications

Capacity:

1,000 lb x 0.2 lb (450 kg x 0.1 kg)

Platform Dimensions Without Ramps:

(W x L x H) 35 in x 29.5 in x 2.375 in

Power:

9 VDC, provided by six AA alkaline batteries (included) or AC adaptor (optional)

Battery Type:

Six AA alkaline (included)

Battery Use:

25 hours continuous use with batteries
Automatic power-off can be configured

Operating Temperature:

50° F to 104° F (10° C to 40° C)

Display:

5-digit LCD display, 0.75 in (1.9 cm) digit height

Approvals:

c-Met, E113986

Warranty:

Two-year limited warranty

Model 350-10-8



Standard Features

- Two wheels for portability
- Dual ramp
- Non-slip platform
- Large 1 in LCD display
- Motiontrap™ movement compensation technology
- Unit of measure toggle or locking
- EHR capable
- USB or Bluetooth® BLE 4.0 available, part number selectable
- Tare function
- Hold function
- BMI (body mass index) function
- Factory calibrated

APPROVALS

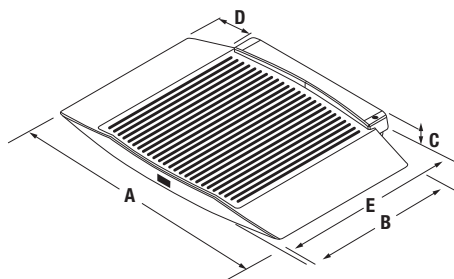

Dimensions

	Inches	Centimeters
A	48.5	123.2
B	32.0	81.3
C	2.4	6.1
D	9.3	23.6
E	38.0	96.5

Part Number/Price

Part #	Model #	Capacity	Price
141449	350-10-8	1,000 lb x 0.2 lb (450 kg x 0.1 kg) with USB	\$1,935.00
194735	350-10-8BLE	1,000 lb x 0.2 lb (450 kg x 0.1 kg) with Bluetooth® BLE 4.0	\$2,170.00

Shipping Weight

Part #	Model #	L (in)	W (in)	H (in)	Package Wgt. (lb)	Dim Wgt. (lb)	Shipping Wgt. (lb)
141449	350-10-8	53	45	7	86	121	121
194735	350-10-8BLE	53	45	7	86	121	121

Options/Accessories

Part #	Description	Price
115655 †	9 VDC adaptor, 120 V/230 V auto switching c-MET medical grade power supply	\$43.00
133077 †	9 VDC adaptor, 120 V/230 V auto switching	\$25.00
102508 ††	9 VDC adaptor, 230 V	\$30.00
81076	Epson TM-U220 tape printer	\$445.00
186830	Printer cable, 25-pin D-Sub male to RJ-45, 6 ft	\$69.00



† NEMA 1-15 Plug

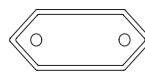

†† CEE 7/16 Plug

RL-350-5

Single-ramp Portable Bariatric Wheelchair Scale

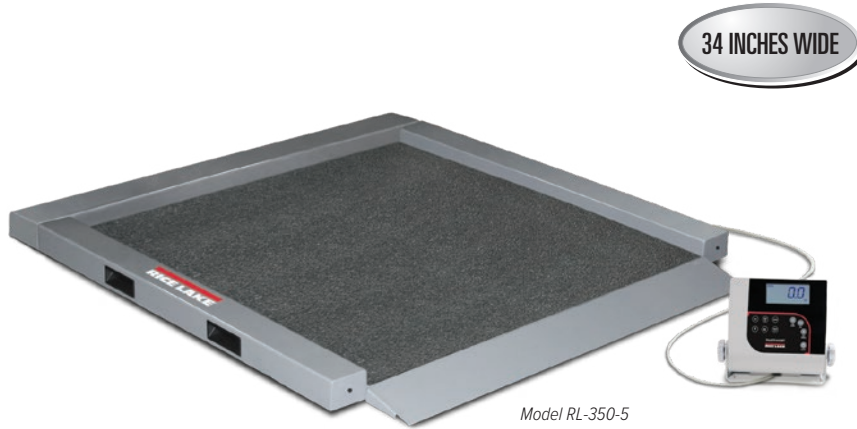

Model RL-350-5

Specifications

Capacity:

1,000 lb x 0.2 lb (450 kg x 0.1 kg)

Platform Dimensions:

(W x L x H) 34 in x 34 in x 2.22 in

Power:

9 VDC, provided by six AA alkaline batteries (included) or AC adaptor (optional)

Battery Type:

Six AA alkaline (included)

Battery Use:

25 hours continuous use with batteries
Automatic power-off can be configured

Operating Temperature:

50° F to 104° F (10° C to 40° C)

Display:

5-digit LCD display, 0.75 in (1.9 cm) digit height

Approvals:

c-Met

Warranty:

Two-year limited warranty

Standard Features

- Integrated handles and wheels for easy transport
- Single ramp
- Large, stable scale base
- Large 1 in LCD display
- Unit of measure toggle or locking
- Motiontrap™ movement compensation technology
- EHR capable
- USB or Bluetooth® BLE 4.0 available, part number selectable
- Tare function
- BMI (body mass index) function
- Hold function
- 10 ft cable between scale base and indicator

APPROVALS



Part Number/Price

Part #	Model #	Capacity	Price
150703	RL-350-5	1,000 lb x 0.2 lb (450 kg x 0.1 kg) with USB	\$2,130.00
205976	RL-350-5BLE	1,000 lb x 0.2 lb (450 kg x 0.1 kg) with Bluetooth® BLE 4.0	\$2,365.00

Shipping Weight

Part #	Model #	L (in)	W (in)	H (in)	Package Wgt. (lb)	Dim Wgt. (lb)	Shipping Wgt. (lb)
150703	RL-350-5	43	43	11	162	147	162
205976	RL-350-5BLE	43	43	11	162	147	162

Options/Accessories

Part #	Description	Price
133077 †	9 VDC adaptor, 120 V/230 V auto switching	\$25.00
102508 ††	9 VDC adaptor, 230 V	\$30.00
81076	Epson TM-U220 tape printer	\$445.00
186830	Printer cable, 25-pin D-Sub male to RJ-45, 6 ft	\$69.00



† NEMA 1-15 Plug



†† CEE 7/16 Plug

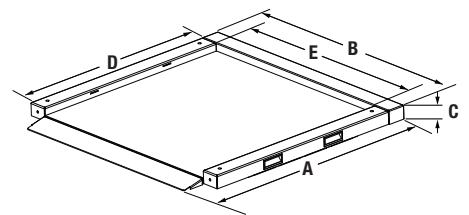

Dimensions

	Inches	Centimeters
A	41.0	104.1
B	40.0	101.6
C	2.2	5.6
D	34.0	86.4
E	34.0	86.4

RL-350-6

Dual-ramp Portable Bariatric Wheelchair Scale

Specifications

Capacity:

1,000 lb x 0.2 lb (450 kg x 0.1 kg)

Platform Dimensions:

(W x L x H) 34 in x 34 in x 2.22 in

Power:

9 VDC, provided by six AA alkaline batteries (included) or AC adaptor (optional)

Battery Type:

Six AA alkaline (included)

Battery Use:

25 hours continuous use with batteries
Automatic power-off can be configured

Operating Temperature:

50° F to 104° F (10° C to 40° C)

Display:

5-digit LCD display, 0.75 in (1.9 cm) digit height

Approvals:

c-Met, E113986

Warranty:

Two-year limited warranty

34 INCHES WIDE

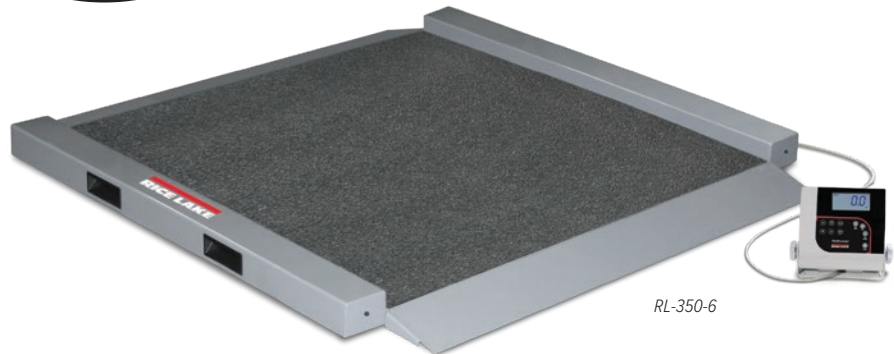

RL-350-6

Standard Features

- Integrated handles and wheels for easy transport
- Dual ramp
- Large, stable scale base
- Large 1 in LCD display
- Unit of measure toggle or locking
- Motiontrap™ movement compensation technology
- EHR capable
- USB or Bluetooth® BLE 4.0 available, part number selectable
- Tare function
- BMI (body mass index) function
- Hold function
- 10 ft cable between scale base and indicator

APPROVALS

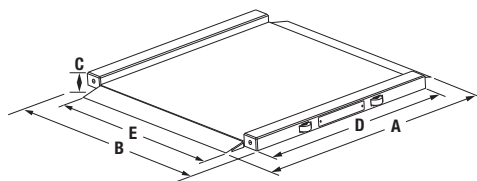

Dimensions

	Inches	Centimeters
A	41.0	104.1
B	40.0	101.6
C	2.2	5.6
D	34.0	86.4
E	34.0	86.4

Part Number/Price

Part #	Model #	Capacity	Price
150704	RL-350-6	1,000 lb x 0.2 lb (450 kg x 0.1 kg) with USB	\$2,130.00
205974	RL-350-6BLE	1,000 lb x 0.2 lb (450 kg x 0.1 kg) with Bluetooth® BLE 4.0	\$2,365.00

Shipping Weight

Part #	Model #	L (in)	W (in)	H (in)	Package Wgt. (lb)	Dim Wgt. (lb)	Shipping Wgt. (lb)
150704	RL-350-6	43	43	11	154	147	154
205974	RL-350-6BLE	43	43	11	154	147	154

Options/Accessories

Part #	Description	Price
133077 †	9 VDC adaptor, 120 V/230 V auto switching	\$25.00
102508 ††	9 VDC adaptor, 230 V	\$30.00
81076	Epson TM-U220 tape printer	\$445.00
186830	Printer cable, 25-pin D-Sub male to RJ-45, 6 ft	\$69.00



† NEMA 1-15 Plug



†† CEE 7/16 Plug

SB-1150 Summit™

Bariatric Wheelchair Scale

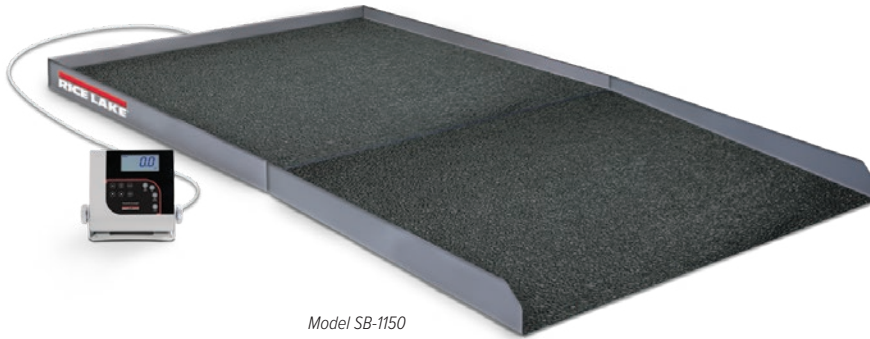

Model SB-1150

Specifications

Capacity:

1,000 lb x 0.2 lb (450 kg x 0.1 kg)

Platform Dimensions:

(W x L x H) 36 in x 36 in x 4 in

Ramp Dimensions:

(W x L x H) 36 in x 28.5 in x 4 in

Display:

5-digit LCD display, 0.75 in (1.9 mm) digit height

Power:

9 VDC, provided by six AA alkaline batteries (included) or AC adaptor (optional)

Battery Type:

Six AA alkaline (included)

Battery Use:

25 hours continuous use with batteries
Automatic power-off can be configured

Operating Temperature:

50° F to 104° F (14° C to 40° C)

Warranty:

Two-year limited warranty

Approvals:

c-Met (pending)

Standard Features

- Heavy-duty mild steel construction
- Single ramp
- Large 1 in LCD display
- Unit of measure toggle or locking
- Motiontrap™ movement compensation technology
- EHR capable
- USB or Bluetooth® BLE 4.0 available, part number selectable
- Tare function
- Hold function
- BMI (body mass index) function
- Factory calibrated
- 10 ft cable between scale base and display

APPROVALS



pending

Part Number/Price

Part #	Model #	Capacity	Price
150706	SB-1150	1,000 lb x 0.2 lb (450 kg x 0.1 kg) with USB	\$1,950.00
205977	SB-1150BLE	1,000 lb x 0.2 lb (450 kg x 0.1 kg) with Bluetooth® BLE 4.0	\$2,185.00

Shipping Weight

Part #	Model #	L (in)	W (in)	H (in)	Package Wgt. (lb)	Dim Wgt. (lb)	Shipping Wgt. (lb)
150706	SB-1150	49	48	24	363	407	407
205977	SB-1150BLE	49	48	24	363	407	407

Options/Accessories

Part #	Description	Price
133077 †	9 VDC adaptor, 120 V/230 V auto switching	\$25.00
102508 ††	9 VDC adaptor, 230 V	\$30.00
81076	Epson TM-U220 tape printer	\$445.00
186830	Printer cable, 25-pin D-Sub male to RJ-45, 6 ft	\$69.00



† NEMA 1-15 Plug

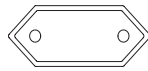

†† CEE 7/16 Plug

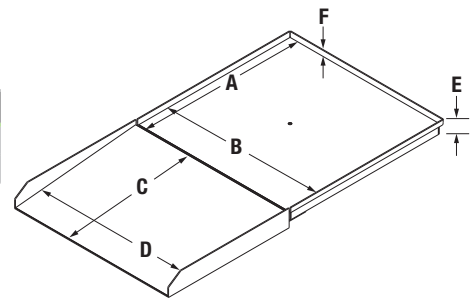

Dimensions

	Inches	Centimeters
A	36.0	91.4
B	36.0	91.4
C	28.5	72.4
D	36.0	91.4
E	4.0	10.2
F	1.0	2.5

SD-1150-WP

Dialysis Wheelchair Scale

Specifications

Capacity:

1,000 lb x 0.2 lb (450 kg x 0.1 kg)

Platform Dimensions:

(W x L x H) 36 in x 36 in x 3 in

Power:

9 VDC, provided by six AA alkaline batteries (included) or AC adaptor (optional)

Battery Type:

Six AA alkaline

Battery Use:

25 hours continuous use with batteries
Automatic power-off can be configured

Operating Temperature:

50° F to 104° F (10° C to 40° C)

Display:

5-digit LCD display, 0.75 in (1.9 cm) digit height

Warranty:

Two-year limited warranty

Approvals:

c-Met, E113986



Wall mounted indicator, cable enclosed in customer supplied conduit.

Model SD-1150-WP

Standard Features

- Package includes scale, pit frame, handrail and indicator
- Heavy-duty mild steel construction
- Handrail for added patient safety
- Large 1 in LCD display
- Unit of measure toggle or locking
- Motiontrap™ movement compensation technology
- EHR capable
- USB or Bluetooth® BLE 4.0 available, part number selectable
- Tare function
- Hold function
- BMI (body mass index) function
- Factory calibrated

APPROVALS

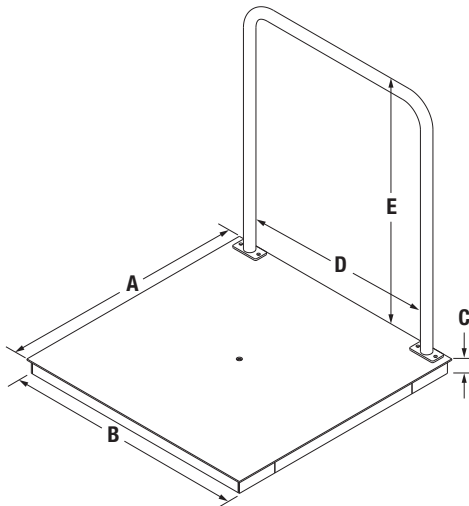

Dimensions

	Inches	Centimeters
A	36.0	91.4
B	36.0	91.4
C	3.0	7.6
D	31.5	80.0
E	37.0	94.0

Part Number/Price

Part #	Model #	Capacity	Price
150707	SD-1150-WP	1,000 lb x 0.2 lb (450 kg x 0.1 kg) with USB	\$2,255.00
205978	SD-1150-WPBLE	1,000 lb x 0.2 lb (450 kg x 0.1 kg) with Bluetooth® BLE 4.0	\$2,490.00

Shipping Weight

Part #	Model #	L (in)	W (in)	H (in)	Package Wgt. (lb)	Dim Wgt. (lb)	Shipping Wgt. (lb)
150707	SD-1150-WP	40	39	15	246	169	246
205978	SD-1150-WPBLE	40	39	15	246	169	246

Options/Accessories

Part #	Description	Price
133077 †	9 VDC adaptor, 120 V/230 V auto switching	\$25.00
102508 ††	9 VDC adaptor, 230 V	\$30.00
81076	Epson TM-U220 tape printer	\$445.00
186830	Printer cable, 25-pin D-Sub male to RJ-45, 6 ft	\$69.00



† NEMA 1-15 Plug

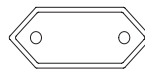

†† CEE 7/16 Plug

SD-1150-WP

Pit Frame Concrete Details

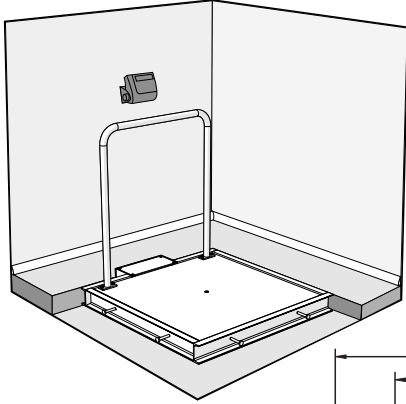
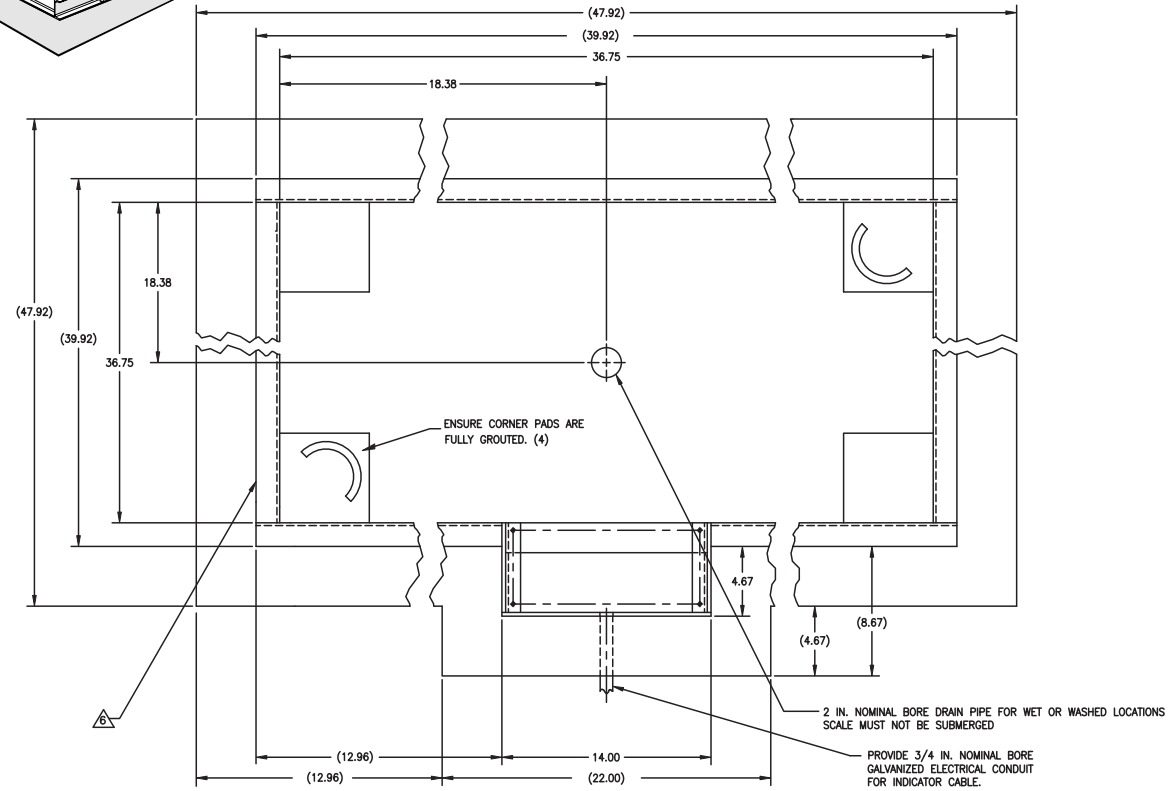
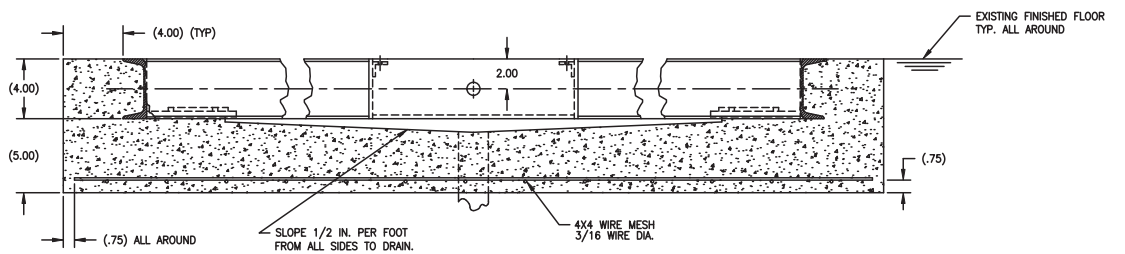

Image illustrates pit frame exposed to show detail.



NOTE: HANDRAIL ON SCALE WILL MOUNT ON SAME SIDE AS JUNCTION BOX POCKET



NOTE:

1. USE CONCRETE OF MINIMUM YIELD STRENGTH 5000 PSI OR 6-BAG MIX.
2. ALLOW 7 DAYS TO CURE. WET CONCRETE PERIODICALLY DURING THIS TIME.
3. DIMENSIONS SHOWN ASSUME FIRM, STABLE SOIL CONDITIONS. WHEN SOIL CONDITIONS ARE NOT ADEQUATE, PLACE FOUNDATION AT SUFFICIENT DEPTH.
4. IN WET OR WASHDOWN APPLICATIONS WE RECOMMEND THE USE OF HERMETICALLY SEALED LOAD CELLS, AND THAT THE JUNCTION BOX BE MOUNTED REMOTELY IN A DRY LOCATION.
5. WIRE MESH TO HAVE MINIMUM .75 COVER BOTTOM AND SIDES.

⚠️ ON STAINLESS STEEL VERSIONS, TWO PIECES OF 2 INCH ANGLE WILL BE SUBSTITUTED FOR THE 4 INCH CHANNEL.

350-10-8S

Digital Stretcher Scales

Specifications

Capacity

1000 lb x 0.2 lb (450 kg x 0.1 kg)

Platform Dimension without Ramps

(W x L x H) 32.7 in x 49.3 in x 2.4 in

Dimensions with Wheels and Ramps

(W x L x H) 34.2 in x 63.7 in x 3.7 in

Power

9 VDC output provided by six AA batteries (included)
230V/120V input provided by AC adapter (optional)

Battery Type

Six AA alkaline (included)

Battery Use

25 hours continuous use with batteries. Automatic power-off can be configured

Operating Temperature

50° F to 104° F (10° C to 40° C)

Display

5-digit LCD display, 0.75 in (1.9 cm) digit height

Warranty

Two-year limited warranty

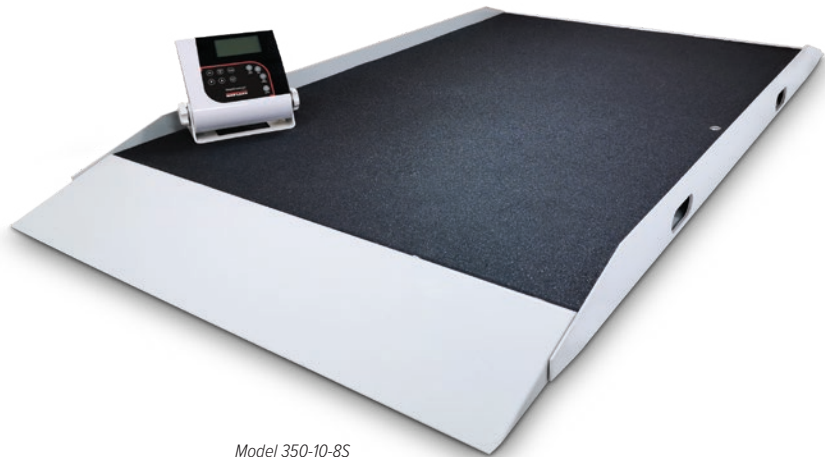

Model 350-10-8S

Standard Features

- Two wheels for portability
- Dual ramp
- Non-slip platform
- Safety side rails
- Push-button LCD display
- Motiontrap™ movement compensation technology
- Unit of measure toggle or locking
- EHR capable
- USB or Bluetooth® BLE 4.0 available, part number selectable
- Tare function
- Hold function
- BMI (body mass index) function
- Factory calibrated
- 7 ft cable between scale base and display

Part Number/Price

Part #	Model #	Capacity	Price
203622	350-10-8S	1,000 lb x 0.2 lb (450 kg x 0.1 kg) with USB	\$2,095.00
203623	350-10-8SBLE	1,000 lb x 0.2 lb (450 kg x 0.1 kg) with Bluetooth® BLE 4.0	\$2,330.00

Shipping Weight

Part #	Model #	L (in)	W (in)	H (in)	Package Wgt. (lb)	Dim Wgt. (lb)	Shipping Wgt. (lb)
203622	350-10-8S	67.2	36	6	154	104	154
203623	350-10-8SBLE	67.2	36	6	154	104	154

Options/Accessories

Part #	Description	Price
133077 †	9 VDC adaptor, 120 V/230 V auto switching	\$25.00
102508 ††	9 VDC adaptor, 230 V	\$30.00
81076	Epson TM-U220 tape printer	\$445.00
186830	Printer cable, 25-pin D-Sub male to RJ-45, 6 ft	\$69.00



† NEMA 1-15 Plug



†† CEE 7/16 Plug

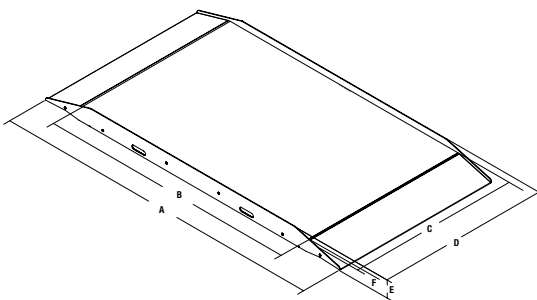

Dimensions

	Inches	Centimeters
A	63.8	162.0
B	49.3	125.3
C	32.7	83.1
D	32.7	83.0
E	3.9	9.8
F	2.6	6.7

