

Indicators / Controllers

NEW Pricing

Prices printed in this catalog may no longer be valid for all products. Please visit www.ricelake.com or call 800-472-6703 for current pricing.

TABLE OF CONTENTS

Indicators / Controllers	491	MSI-8004HD	536	TranSend™	555
120/120 Plus	492	<i>Digital Weight Indicator/RF Remote Display</i>		<i>Wireless Load Cell Interface System</i>	
<i>Digital Weight Indicator</i>		SCT-1100	538	SendIt™	556
CW-90	494	<i>Signal Conditioning Transmitter</i>		<i>Wireless Load Cell Interface System</i>	
<i>Checkweigh Indicator</i>		SCT-2200	539	ConnexLink™	557
CW-90X	496	<i>Signal Conditioning Transmitter</i>		<i>Wireless Radio 900 MHz Transceivers</i>	
<i>Checkweigh Indicator</i>		SCT-3300	540	Industrial Broadband	558
380 Synergy Series	498	<i>Signal Conditioning Transmitter</i>		Ubiquiti® NanoStation®	559
<i>Digital Weight Indicator</i>		SCT-1PX	541	Visible Lights and Audible Alarms	559
380X Synergy Series	499	<i>Transmitter with Integrated Fieldbus and Web Server</i>		Manual Pushbuttons/ Pushbutton Switches	559
<i>Washdown Digital Weight Indicator</i>		SCT-1SX	542	INDUSTRIAL CONTROL PRODUCTS	
381 Synergy Series	500	<i>Transmitter with Integrated Fieldbus and Web Server</i>		USB to Serial Converter/Adapter	560
<i>Digital Weight Indicator</i>		SCT-4X	543	<i>Serial Adapters</i>	
680 Synergy Series	501	<i>Integrated Fieldbus Transmitter</i>		Amphenol® RJF 544	561
<i>Digital Weight Indicator</i>		SCT-10	544	<i>Harsh Environment Ethernet Connection System</i>	
682 Synergy Series	503	<i>Signal Conditioning Transmitter</i>		AbleCable®	562
<i>Digital Weight Indicator</i>		SCT-20	545	<i>Serial Adapter RS-232 Cable to USB</i>	
680HE Synergy Series	505	<i>Signal Conditioning Transmitter</i>		Go-Between™	563
<i>Hostile Environment Digital Weight Indicator</i>		SCT-30	546	<i>Data Capture and Storage</i>	
720i™ Series	506	<i>Signal Conditioning Transmitter</i>			
<i>Programmable Digital Weight Indicator/Controller</i>		SCT-40	547		
880/880 Plus Performance™ Series	509	<i>Signal Conditioning Transmitter</i>			
<i>Programmable Digital Weight Indicator/Controller</i>		FIELDBUS CARDS			
920i® Series	513	PROFIBUS® DP Interface	548		
<i>Programmable Digital Weight Indicator</i>		<i>720i™/920i®</i>			
1280 Enterprise™ Series	517	PROFINET IO Interface	548		
<i>Programmable Digital Weight Indicator</i>		<i>920i®</i>			
Relays and Racks	522	DeviceNet® Interface	549		
<i>Input/Output Components</i>		<i>720i™/920i®</i>			
LaserLight3™	523	ControlNet® Interface	549		
<i>Color Large-display Weight Indicator</i>		<i>920i®</i>			
LaserLT-60 and LaserLT-100	525	EtherNet/IP™ Interface	550		
<i>Large-display Digital Weight Indicators</i>		<i>720i™/920i®</i>			
1280 Enterprise™ Series	526	Ethernet TCP/IP Interface	551		
<i>User Programs</i>		<i>720i™/920i®</i>			
920i® Series	528	PROFIBUS® DP Interface	552		
<i>User Programs</i>		<i>880™/882D/882IS/1280™</i>			
920i® FlexWeigh Systems	530	PROFINET Interface	552		
<i>Fillers/Batchers</i>		<i>880™/882D/882IS/1280™</i>			
920i® FlexWeigh Systems	532	DeviceNet® Interface	553		
<i>Bulkweighers and Flip Flop Fillers</i>		<i>880™/882D/882IS/1280™</i>			
920i® FlexWeigh Systems	533	Modbus TCP Interface	553		
<i>Flow Rate Controllers</i>		<i>880™/882D/882IS/1280™</i>			
920i® FlexWeigh Systems	533	EtherNet/IP™ Interface	554		
<i>Hand Batching</i>		<i>880™/882D/882IS/1280™</i>			
MSI-8000HD	534	EtherCAT® Interface	554		
<i>Digital Weight Indicator/RF Remote Display</i>		<i>880™/882D/882IS/1280™</i>			

INDICATORS / CONTROLLERS

Product names, logos, brands and other trademarks featured or referred to within this publication are the property of their respective trademark holders.

120/120 Plus

Digital Weight Indicator



INDICATORS /
CONTROLLERS

Approvals



Measurement
Canada
Approved



Standard Features

120

- LED display
- Configurable analog to digital measurement rate
- Primary/secondary units configuration: lb, kg, ounces, grams
- Five-button operation
- Two independent communication ports
- Programmable ticket format, up to two 180-character printout
- Full front-panel digital calibration and configuration
- Tilt stand
- Three-stage digital filtering
- Consecutive transaction numbering
- Time and date (volatile)

120 Plus

- LCD display
- Internal rechargeable lithium battery and wall adapter
- Power save feature for 700 hours of battery life
- Ten stored tare values
- Display hold (based on three second average)
- Time and date
- Configurable with Revolution® software

Specifications

Power:

Line voltages: 115 or 230 VAC
Frequency: 50/60 Hz

Battery Life:

120 Plus
60 hours with one 350 ohm load cell,
40 hours with four 350 ohm load cells
Eight-hour charge time

Excitation Voltage:

5 VDC, 4 × 350 ohm or 8 × 700 ohm load cells

Analog Signal Input Range:

-0.6 mV/V to 3.0 mV/V

Analog Signal Sensitivity:

0.3 μV/graduation minimum,
1.5 μV/grad recommended

A/D Sample Rate:

120: 3 to 30 Hz, software selectable
120 Plus: 30 Hz

Resolution:

Internal: 1,000,000 counts
Display: 10,000

System Linearity:

Within 0.01% of full scale

(Optional) Digital I/O:

120 Plus: Requires option card
24 volt source
Three digital inputs
Two digital outputs

Circuit Protection:

RFI, EMI, ESD protected

Load Cell Connection:

Cord grip entry
Detachable plug (optional)

Communication Port:

EDP port: Full duplex RS-232
Printer port: Output-only RS-232
or active 20 mA current loop
Both ports: 9600, 4800, 2400, 1200, 600, 300bps;
Seven or eight data bits; even, odd or no parity

Annunciators:

120/120 Plus: Center of zero, standstill, gross,
net, lb, kg, oz, g
120 Plus: Battery, setpoint 1 and 2, hold

Display:

120: 0.8 in (20 mm), six-digit red light emitting
diode (LED) display, seven-segment digits
120 Plus: 0.8 in (20 mm) six-digit LCD with
backlight, seven-segment digits

Keys/Buttons:

120: Five-key flat membrane panel, tactile feel
120 Plus: Zero, tare, preset tare, hold, gross/net,
units, numeric 0-9, clear, enter/print

Temperature:

Certified: 14 °F to 104 °F (-10 °C to 40 °C)
Operating: 14 °F to 122 °F (-10 °C to 50 °C)

Rating/Material:

Enclosure: Heavy gauge ABS

Weight:

2.6 lb (1.2 kg)

Warranty:

One-year limited

Approvals:

NTEP 03-059 Class III/IIIL 10,000 d
Measurement Canada AM-5517
EU Test Certificate TC7626
CE Marked

Part Number/Price

Part #	Description	Est. Weight	Price
120			
131923	Desktop 115 VAC/230 VAC	3 lb	\$575.00
120 Plus			
103632	Desktop 115/230 VAC	3 lb	\$720.00
107619	Desktop 115/230 VAC with digital I/O option	3 lb	\$760.00

NOTE: Both plugs included with power supply



US Plug



Euro Plug

Options/Accessories

Part #	Description	Price
93205	Load cell connector with 6 m length pigtail (requires 103507)	\$60.00
82505	Six-pin socket external load cell connector (requires 103507)	\$16.00
103507	External load cell plug replaces cord grip (requires 82505 or cable 93205)	\$42.00
107620	Digital I/O card for 120 Plus	\$95.00
105670	15-pin connector for 120 Plus	\$14.00
106705	15-pin Interface cable for 120 Plus, 2 m length	\$39.00
76699	Additional operating manual for 120	\$39.00
105914	Additional operating manual for 120 Plus	\$37.00
Primary Component Parts for 120		
131924	Board assembly for use with internal load cell connector	\$315.00
78610	Overlay membrane switch	\$70.00
131925	Power supply, 115 VAC/230 VAC	\$47.00
64794	Cable, null modem DB9F to DB9M	\$69.00
Primary Component Parts for 120 Plus		
103634	CPU/Display board assembly	\$430.00
103635	Overlay membrane switch	\$70.00
103636	Power supply, 115 VAC/230 VAC	\$47.00
103637	Rechargeable battery	\$100.00

Revolution® can be downloaded for free at www.ricelake.com

To have your option factory installed, please specify when placing your order.

Dimensions

120/120 Plus			
A	7.32 in (186 mm)	D	1.65 in (42 mm)
B	6.06 in (154 mm)	E	4.76 in (121 mm)
C	3.74 in (95 mm)		

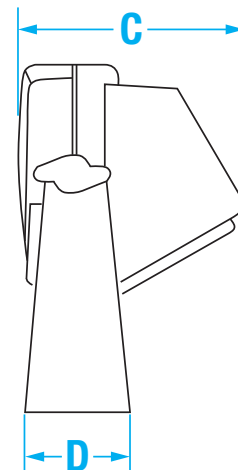
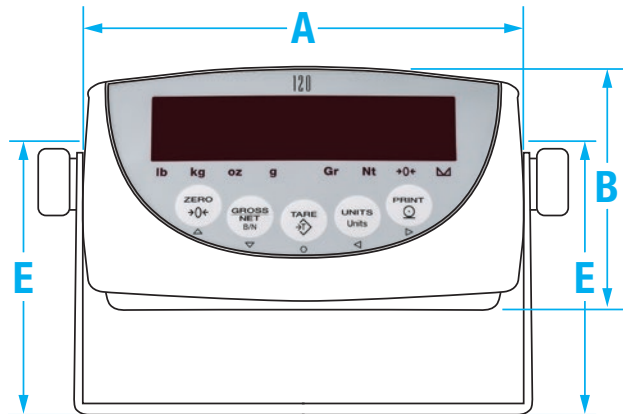

CW-90

Checkweigh Indicator



INDICATORS /
CONTROLLERS

Approvals



Measurement
Canada
Approved



EU
LEGAL
FOR TRADE
CERTIFIED



Dimensions

CW-90	
A	9.50 in (241 mm)
B	10.02 in (255 mm)
C	11.24 in (285 mm)
D	3.12 in (79 mm)
E	6.00 in (152 mm)
F	8.57 in (218 mm)
G	3.75 in (95 mm)
H	4.00 in (102 mm)

Standard Features

- Gore-Tex® breather vent
- Storage for up to 50 IDs
- Unit of measure: kg, gm, lb, oz, lb/oz
- LED display
- Two full duplex serial ports
- Configurable print formats
- Audit trail tracking
- Optional communications: Ethernet, USB or fiber-optic
- Four configurable digital I/O
- Firmware is field upgradeable by reflashing memory
- Auto print capability
- Battery backed up time and date
- Accumulator
- Membrane keypad consisting of zero, print, tare, over, under, target, 0 to 9, clear, decimal, enter, menu, power

Specifications

Power:

Line voltages: 115 to 230 VAC
Frequency: 50/60 Hz

Power Consumption:

1.5 A at 115 VAC (8 W)
0.75 A at 230 VAC (8 W)

Excitation Voltage:

+5 VDC 8 × 350 ohm or 16 × 700 ohm load cells

Analog Signal Input Range:

-0.5 mV/V to 4.5 mV/V

Analog Signal Sensitivity:

0.3 uV/graduation minimum
1.5 uV/graduation recommended

A/D Sample Rate:

7.5 to 960 Hz software selectable

Resolution:

Display: 100,000 counts

System Linearity:

± 0.01% full scale

Digital I/O:

Four channels on CPU board

Circuit Protection:

RFI, EMI, ESD protection

Annunciators:

Designators for percent, kg, gm, lb, oz, center of zero, G/B, N, T, PT, neg, motion

Display:

Large 0.8 in 14-segment, six-digit high-intensity red LED display

Keys/Buttons:

Membrane keypad, 23 keys with international symbols

Temperature:

Certified: 14 °F to 104 °F (-10 °C to 40 °C)

Rating/Material:

IP66, 304 stainless steel

Warranty:

Two-year limited

Approvals:

NTEP 08-092, Class III/IIIL 10,000 d
Measurement Canada AM-5710
OIML R76/2006-GBI-10.02
EU Evaluation Cert TC11569
CE Marked
NSF
cULus Listed

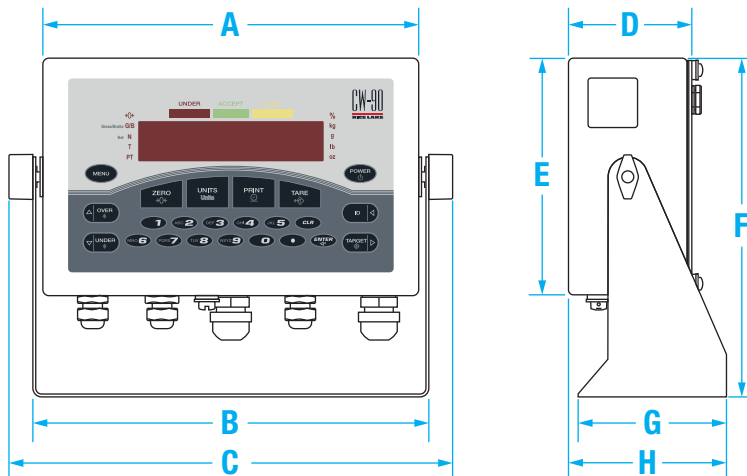

Part Number/Price

Part #	Description	Est. Weight	Price
105970 [†]	CW-90, 115 VAC	7 lb	\$1,045.00
105971 ^{††}	CW-90, 230 VAC, CE marked/OIML approved	7 lb	\$1,045.00
118888 [†]	CW-90, 230 VAC	7 lb	\$1,045.00
171247 ^{†††}	CW-90, 230 VAC	7 lb	\$1,045.00



[†] US plug (NA) - Type B



^{††} Euro Plug - Type E



^{†††} IEC Type I plug

Options/Accessories

Part #	Description	Price
200578	Ethernet TCP/IP, 10 ft cable included	\$595.00
206272	RS-232/Wi-Fi interface 802.11 A/B	\$610.00
95357	USB cable, Type A to mini-B, 1 m	\$11.00
171968	Firmware download cable	\$39.00
117358	WeighVault® (requires part number 200578 or 206272)	\$265.00

To have your option factory installed, please specify when placing your order.

CW-90X

Checkweigh Indicator



INDICATORS /
CONTROLLERS

Approvals



Measurement
Canada
Approved



EU
LEGAL
FOR TRADE
CERTIFIED



Dimensions

CW-90X	
A	9.50 in (241 mm)
B	10.02 in (255 mm)
C	11.24 in (285 mm)
D	3.12 in (79 mm)
E	6.00 in (152 mm)
F	8.57 in (218 mm)
G	3.75 in (95 mm)
H	4.00 in (102 mm)

Standard Features

- Gore-Tex® breather vent
- Storage for up to 50 IDs
- Unit of measure: kg, gm, lb, oz, lb/oz
- LED display
- Two full duplex serial ports
- Configurable print formats
- Audit trail tracking
- Optional communications: Ethernet, USB or fiber-optic
- Four configurable digital I/O
- Firmware is field upgradeable by reflashing memory
- Auto print capability
- Battery backed up time and date
- Accumulator
- Piezo keypad consisting of zero, under, menu, power

Specifications

Power:

Line voltages: 115 to 230 VAC
Frequency: 50/60 Hz

Power Consumption:

1.5 A at 115 VAC (8 W)
0.75 A at 230 VAC (8 W)

Excitation Voltage:

+5 VDC 8 × 350 ohm or 16 × 700 ohm load cells

Analog Signal Input Range:

-0.5 mV/V to 4.5 mV/V

Analog Signal Sensitivity:

0.3 uV/graduation minimum
1.5 uV/graduation recommended

A/D Sample Rate:

7.5 to 960 Hz software selectable

Resolution:

Display: 100,000 counts

System Linearity:

± 0.01% full scale

Digital I/O:

Four channels on CPU board

Circuit Protection:

RFI, EMI, ESD protection

Annunciators:

Designators for percent, kg, gm, lb, oz, center of zero, G/B, N, T, PT, neg, motion

Display:

Large 0.8 in 14-segment, six-digit high-intensity red LED display

Keys/Buttons:

Piezo keypad, 11 keys with international symbols

Temperature Range:

Certified: 14 °F to 104 °F (-10 °C to 40 °C)

Rating/Material:

IP69K, 304 stainless steel

Warranty:

Three-year limited

Approvals:

NTEP 08-092, Class III/IIIL 10,000 d
Measurement Canada AM-5710
OIML R76/2006-GBI-10.02
EU Eval Certificate TC11569
CE Marked
NSF
cULus Listed

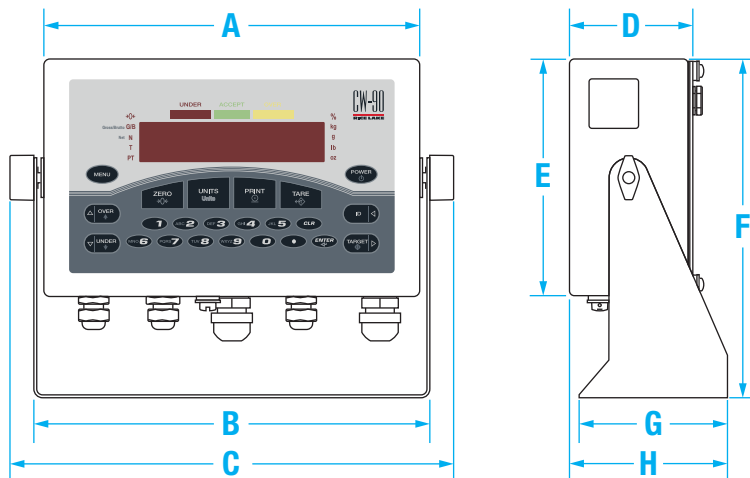

Part Number/Price

Part #	Description	Est. Weight	Price
105972 [†]	CW-90X, 115 VAC	7 lb	\$1,095.00
105973 ^{††}	CW-90X, 230 VAC, CE marked/OIML approved	7 lb	\$1,095.00
118889 [†]	CW-90X, 230 VAC	7 lb	\$1,095.00
171248 ^{†††}	CW-90X, 230 VAC	7 lb	\$1,095.00



[†] US plug (NA) - Type B



^{††} Euro Plug - Type E



^{†††} IEC Type I plug

Options/Accessories

Part #	Description	Price
200578	Ethernet TCP/IP, 10 ft cable included	\$595.00
206272	RS-232/Wi-Fi interface 802.11 A/B	\$610.00
95357	USB cable, Type A to mini-B, 1 m	\$11.00
171968	Firmware download cable	\$39.00
117358	WeighVault® (requires part number 200578 or 206272)	\$265.00

To have your option factory installed, please specify when placing your order.

380 Synergy Series

Digital Weight Indicator



INDICATORS /
CONTROLLERS

Approvals



Measurement
Canada
Approved



Standard Features

- LCD display
- Alkaline battery powered
- Push-button and keyed tare
- Two communication ports
- Configurable print formats

Options

- Time/date
- External power supply

Part Number/Price

Part #	Description	Est. Weight	Price
202711	380 Universal battery powered	6.25 lb (3 kg)	\$725.00

Options/Accessories

Part #	Description	Price
206433†	External AC adapter	\$60.00
204258	Real time clock module	\$127.00
223864	Knob, stainless steel M6 x 1.0 inch	\$15.00

To have your option factory installed, please specify when placing your order.



† US plug (NA) - Type A

Dimensions

380 Synergy Series			
A	9.50 in (241 mm)	D	11.58 in (294 mm)
B	6.00 in (152 mm)	E	4.53 in (115 mm)
C	8.57 in (218 mm)	F	3.53 in (90 mm)

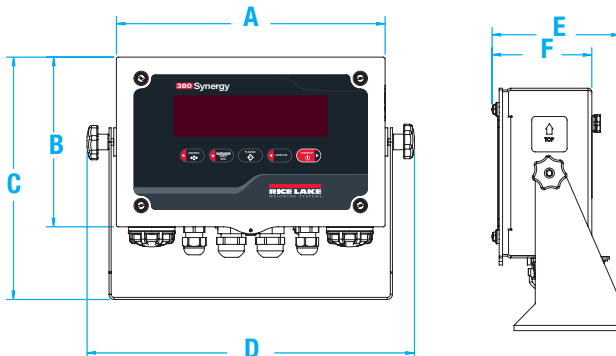

Specifications

Power:

Batteries: Four alkaline C-cell (not included)
Optional: 115/230 VAC to 12 VDC adapter

Power Consumption:

6 W max with optional external power adapter

Battery Life:

100 hours with one 350 ohm load cell, no backlight
45 hours with four 350 ohm load cells, low backlight
20 hours with eight 350 ohm load cells, low backlight

Excitation Voltage:

5 VDC, 8 × 350 ohm or 16 × 700 ohm load cells

Analog Signal Input Range:

-0.3 mV to +30 mV
Common mode voltage 0.7 V to 3.3 V

Analog Signal Sensitivity:

1 μV/graduation recommended

A/D Sample Rate:

Gen 1: 5, 6, 10, 12, 20, 25, 40, 50, 80, 100Hz
Software selectable
Gen 2: 6, 8, 12, 15, 30, 50, 60, 100, 120 Hz
Software selectable

Resolution:

Internal: 8,000,000 counts
Display: 100,000

System Linearity:

Within 0.01% full scale

Communication Ports:

One full-duplex RS-232
One USB 2.0

Annunciators:

g, lb, t, tn, kg, oz, battery level, PT, LT, gross, zero, unstable, net

Display:

Six 1 in (25 mm) tall, LCD digits

Keys/Buttons:

Five tactile buttons

Dimensions:

(L × W × H)
11.58 × 4.53 × 8.57 in
(294 × 115 × 218 mm)

Temperature:

Certified: 14 °F to 104 °F (-10 °C to 40 °C)
Industrial: 14 °F to 122 °F (-10 °C to 50 °C)

Rating/Material:

IP66, 304 stainless steel

Weight:

6.25 lb (3 kg)

Warranty:

Two-year limited

EMC Immunity:

10 V/m

Approvals:

NTEP 21-051 Class III/IIIL 10,000 d
Measurement Canada AM-6184
CE Marked
UKCA
cULus Listed
IEC

380X Synergy Series

Washdown Digital Weight Indicator



Specifications

Power:

Battery: Lithium ion
Charger: 120 VAC internal

Power Consumption:

25 W max with internal power

Battery Life:

45 hours, one 350 ohm load cell, no backlight
15 hours, four 350 ohm load cells, no backlight
10 hours, eight 350 ohm load cells, backlight

Excitation Voltage:

5 VDC, 8 × 350 ohm or 16 × 700 ohm load cells

Analog Signal Input Range:

-0.3 mV to +30 mV
Common mode voltage 0.7 V to 3.3 V

Analog Signal Sensitivity:

1 µV/graduation recommended

A/D Sample Rate:

Gen 1: 5, 6, 10, 12, 20, 25, 40, 50, 80, 100 Hz
Software selectable
Gen 2: 6, 8, 12, 15, 30, 50, 60, 100, 120 Hz
Software selectable

Resolution:

Internal: 8,000,000 counts
Display: 100,000

System Linearity:

Within 0.01% full scale

Communication Ports:

One full-duplex RS-232 (three-wire)
One USB 2.0

Annunciators:

g, lb, t, tn, kg, oz, battery level, PT, LT, gross, zero, unstable, net

Display:

Six 1 in (25 mm) tall, LCD digits

Keys/Buttons:

Five-tactile buttons

Dimensions:

(L × W × H)
11.58 × 4.53 × 8.57 in
(294 × 115 × 218 mm)

Temperature:

Certified: 14 °F to 104 °F (-10 °C to 40 °C)
Operating: 14 °F to 122 °F (-10 °C to 50 °C)

Rating/Material:

IP69K, 304 Stainless steel

Weight:

6.25 lb (3 kg)

Warranty:

One-year limited on battery
Two-year limited on indicator and parts

EMC Immunity:

10 V/m

Approvals:

NTEP 21-051
Measurement Canada AM-6184
CE
UKCA
cULus
IEC

INDICATORS / CONTROLLERS

Approvals



Measurement
Canada
Approved



Standard Features

- LCD display
- Battery powered, internal charger
- Push button and keyed tare
- Two communication ports
- Five-tactile buttons
- Configurable print formats

Options

- Time/date

Part Number/Price

Part #	Description	Est. Weight	Price
214337	380X Universal battery powered	6.25 lb (3 kg)	\$820.00

Options/Accessories

Part #	Description	Price
204258	Real time clock module	\$127.00
223864	Knob, stainless steel M6 x 1.0 inch	\$15.00

To have your option factory installed, please specify when placing your order.



† US plug (NA) - Type B

Dimensions

380X Synergy Series			
A	9.50 in (241 mm)	D	11.58 in (294 mm)
B	6.00 in (152 mm)	E	4.53 in (115 mm)
C	8.57 in (218 mm)	F	3.53 in (90 mm)

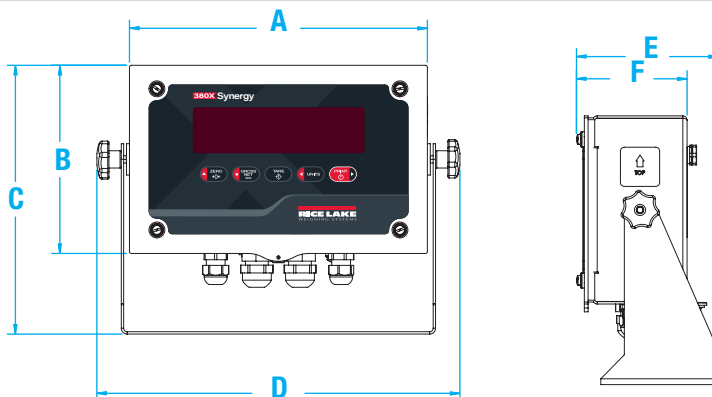

381 Synergy Series

Digital Weight Indicator



Approvals



Measurement
Canada
Approved



INDICATORS /
CONTROLLERS

Standard Features

- LCD display
- Battery powered
- Push-button and keyed tare
- Two communication ports
- Five tactile buttons
- Configurable print formats
- ABS enclosure

Options

- Time/date

Part Number/Price

Part #	Description	Price
215695	381 Universal, AA battery powered	\$415.00
215696	381 Universal, Nickel metal hydride (NiMH) battery powered	\$515.00

Options/Accessories

Part #	Description	Price
215273	RS-232 DB9 cable, 1.5 m DB9 female RJ11 connector, compatible with 381 model	\$95.00
204258	Real time clock module	\$127.00
216647	3 mm t-handle hex key	\$6.00
223864	Knob, stainless steel M6 x 1.0 inch	\$15.00

To have your option factory installed, please specify when placing your order.



† US plug (NA) - Type B

Dimensions

381 Synergy Series			
A	6.77 in (172 mm)	D	8.50 in (216 mm)
B	3.82 in (97 mm)	E	3.17 in (81 mm)
C	5.06 in (129 mm)	F	1.77 in (45 mm)

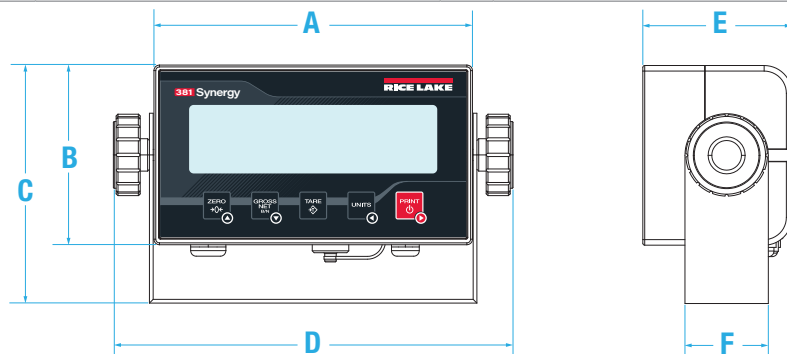

Specifications

Power:

Battery: AA or Nickel Metal Hydride (NiMH)
381-2D-AA Adapter: 115/230 VAC to 12 VDC
381-2D-NiMH Charger: 115/230 VAC

Power Consumption:

AA: input 0.8 A
(6 W while using AC adapter)
NiMH: input of 0.35 A

Battery Life:

AA: 40 hours with one 350 ohm load cell
NiMH: 80 hours with one 350 ohm load cell

Excitation Voltage:

5 VDC, 8 × 350 ohm or 16 × 700 ohm load cells

Analog Signal Input Range:

-0.3 mV to +30 mV
common mode voltage
0.7 V to 3.3 V

Analog Signal Sensitivity:

1 μV/graduation recommended

A/D Sample Rate:

Gen 1: 5, 6, 10, 12, 20, 25, 40, 50, 80, 100Hz
Software selectable
Gen 2: 6, 8, 12, 15, 30, 50, 60, 100, 120 Hz
Software selectable

Resolution:

Internal: 8,000,000 counts
Display: 100,000

System Linearity:

Within 0.01% full scale

Communication Ports:

One full-duplex RS-232
One USB 2.0

Annunciators:

g, lb, t, tn, kg, oz, battery level, PT, LT, gross, zero, unstable, net

Display:

Six 1 in (25 mm) tall, LCD digits

Keys/Buttons:

Five tactile buttons

Dimensions:

(L × W × H)
8.50 × 3.17 × 5.06 in
(215.8 × 80.5 × 128.5 mm)

Temperature:

Certified: 14 °F to 104 °F (-10 °C to 40 °C)
Operating: 14 °F to 122 °F (-10 °C to 50 °C)

Rating/Material:

AA Battery: IP54, ABS
NiMH Battery: IP66, ABS

Warranty:

Two-year limited

EMC Immunity:

10 V/m

Approvals:

NTEP 21-051 Class III/IIIL, 10,000 d
Measurement Canada AM-6184
CE Listed
UKCA

680 Synergy Series

Digital Weight Indicator



Specifications

Power:

Line voltages: 100 to 240 VAC
Frequency: 50 to 60 Hz

Power Consumption:

2 W (AC) one 350 ohm load cell, 15 W max

Excitation Voltage:

10 VDC (± 5 VDC), 8 \times 350 ohm or
16 \times 700 ohm load cells

Analog Signal Input Range:

-5 mV to +70 mV

Analog Signal Sensitivity:

0.3 μ V/graduation minimum
1 μ V/graduation recommended

A/D Sample Rate:

6.25 to 120 Hz, software selectable

Resolution:

Internal: 8,000,000 counts
Display: 1,000,000

System Linearity:

Within 0.01% full scale

Digital I/O:

Four configurable I/O - 5 V logic

(Optional) Analog Output:

16-bit resolution, voltage output 0-10 VDC,
current output 0-20 mA/4-20 mA

Communication Ports:

Two full-duplex RS-232
RS-485/422 (five-wire)
Micro USB (device)
Ethernet TCP/IP (10/100)

Annunciators:

Eight LED annunciators

Display:

Seven 0.8 in tall, seven-segment digits

Keys/Buttons:

Flat membrane panel, tactile feel
(18 buttons plus ON/OFF)

Dimensions:

(L \times W \times H)
11.58 \times 4.05 \times 8.57 in
(294 \times 103 \times 218 mm)

Temperature:

Certified: 14 $^{\circ}$ F to 104 $^{\circ}$ F (-10 $^{\circ}$ C to 40 $^{\circ}$ C)
Industrial: 14 $^{\circ}$ F to 122 $^{\circ}$ F (-10 $^{\circ}$ C to 50 $^{\circ}$ C)

Rating/Material:

IP69K (IP66 with RJ45)
AISI 304 stainless Steel

Weight:

6.25 lb (3 kg)

Warranty:

Two-year limited

EMC Immunity:

10 V/m

Approvals:

NTEP 19-021, Class III/IIIL, 10,000 d
Measurement Canada AM-6121C
OIML R76/2006-A-NL1-19.56
NOM
EU Eval Certificate TC11562
CE Listed
UKCA
cULus Listed
IEC
NMI

INDICATORS /
CONTROLLERS

Approvals



Measurement
Canada
Approved



EU
LEGAL
FOR TRADE
CERTIFIED



National
Measurement
Institute

Standard Features

- LED display
- Battery backed time and date
- Full numeric keypad
- Multiple communication ports
- 20 setpoint, 22 configurable types
- Numeric keyed entry for tare and setpoint entry
- Formattable tickets
- Four onboard configurable digital I/O points, TTL logic
- Built-in batch presets
- Local/remote

Options

- Analog output: 16-bit resolution, 0-10 VDC, 0-20 mA, 4-20 mA
- RJ45 Ethernet connector

Note: IP Rating is IP66 with RJ45 option. Rating is valid only when the cover is in place, not in use.

Dimensions

680 Synergy Series			
A	10.02 in (255 mm)	E	3.40 in (86 mm)
B	11.58 in (294 mm)	F	4.05 in (103 mm)
C	6.00 in (152 mm)	G	3.80 in (97 mm)
D	8.57 in (218 mm)	H	4.74 in (120 mm)

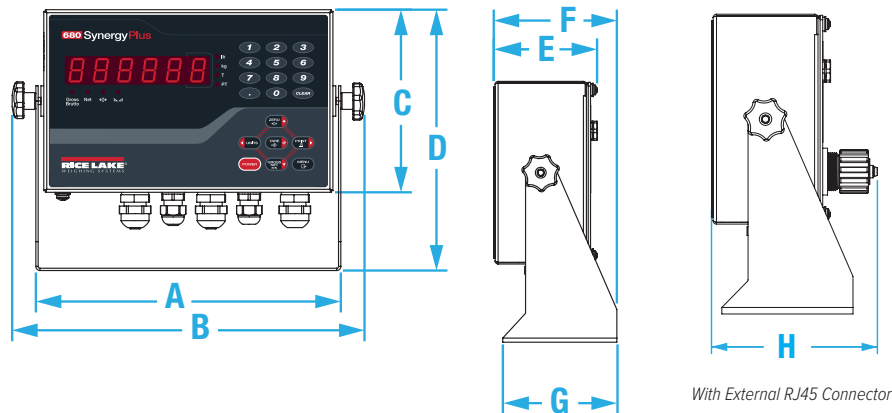

With External RJ45 Connector

680 Synergy Series

Digital Weight Indicator

Part Number/Price

Part #	Description	Est. Weight	Price
115 to 230 VAC			
193152 [†]	680 Plus indicator, LED display, US power cord	7 lb	\$1,025.00
193153 ^{††}	680 Plus indicator, LED display, EU power cord	7 lb	\$1,025.00
196326 ^{†††}	680 Plus indicator, LED display, UK power cord	7 lb	\$1,025.00
196327 ^{††††}	680 Plus indicator, LED display, AUS power cord	7 lb	\$1,025.00
9 to 36 VDC			
193154 [*]	680 Plus indicator, LED display	7 lb	\$1,140.00
With Analog Output Card			
195176 [†]	680 Plus indicator, LED display, 115-230 VAC with analog output card, US power cord	7 lb	\$1,350.00
195177 ^{††}	680 Plus indicator, LED display, 115-230 VAC with analog output card, EU power cord	7 lb	\$1,350.00
196539 ^{†††}	680 Plus indicator, LED display, 115-230 VAC with analog output card, UK power cord	7 lb	\$1,350.00
196538 ^{††††}	680 Plus indicator, LED display, 115-230 VAC with analog output card, AUS power cord	7 lb	\$1,350.00
With External RJ45 Connector**			
200183 [†]	680 Plus Indicator, LED display, 115-230 VAC with RJ45, US power cord	7 lb	\$1,175.00
200184 ^{††}	680 Plus Indicator, LED display, 115-230 VAC with RJ45, EU power cord	7 lb	\$1,175.00
200185 ^{†††}	680 Plus Indicator, LED display, 115-230 VAC with RJ45, UK power cord	7 lb	\$1,175.00
200186 ^{††††}	680 Plus Indicator, LED display, 115-230 VAC with RJ45, AUS power cord	7 lb	\$1,175.00

^{*}Not UL approved

^{**}IP rating is IP66 with RJ45 option

INDICATORS / CONTROLLERS

Options/Accessories

Part #	Description	Price
195084	Analog output option card	\$360.00
151099	Panel mount option, gasketed non-NEMA seal	\$215.00
223864	Knob, stainless steel M6 x 1.0 in	\$15.00
195684	CPU board	\$505.00
194477	Parts kit	\$33.50

To have your option factory installed, please specify when placing your order.



[†] US plug (NA) - Type B



^{††} Euro Plug - Type E



^{†††} BS1363 (UK) - Type G



^{††††} AS 3112 (Australian) - Type I

682 Synergy Series

Digital Weight Indicator



Specifications

Power:

Line voltage: 100 to 240 VAC, 50/60 Hz
Optional: 9 to 36 VDC

Power Consumption:

3.2 W (AC) one 350 ohm load cell, 15 W max;
4 W four 350 ohm load cells or
eight 700 ohm load cells

Excitation Voltage:

10 VDC (± 5 VDC), 8 \times 350 ohm or
16 \times 700 ohm load cells

Analog Signal Input Range:

-5 mV to +70 mV

Analog Signal Sensitivity:

0.3 μ V/graduation minimum
1 μ V/graduation recommended

A/D Sample Rate:

6.25 to 120 Hz, software selectable

Resolution:

Internal: 8,000,000 counts
Display: 1,000,000

System Linearity:

Within 0.01% full scale

Digital I/O:

Four configurable I/O, 5 V logic

(Optional) Analog Output:

16-bit resolution, voltage output 0 to 10 VDC,
current output 0 to 20 mA/4 to 20 mA

(Optional) Relay Board:

Four normally open dry contact relays and can
switch 20 to 250 VAC @ 3 A or 30 VDC @ 3 A.
Use of external fusing to limit current is
recommended. Relay COM-NO are transient
protected to 400 V @ 600 W

Communication Ports:

Two full-duplex RS-232
RS-485/422 (two-wire or four-wire)
Micro USB (device)
Ethernet TCP/IP (10/100)
Wi-Fi

Annunciators:

Zero, Gross/Net, Tare, Wi-Fi, WPAN

Display:

Five-inch LCD, 800 \times 480 pixel, 500 NIT

Keys/Buttons:

Flat membrane panel, tactile feel
18 buttons plus five softkeys and power

Dimensions:

(L x W x H)
10.0 \times 4.0 \times 8.6 in
(254 \times 102 \times 218 mm)

Temperature:

Certified: 14 $^{\circ}$ F to 104 $^{\circ}$ F (-10 $^{\circ}$ C to 40 $^{\circ}$ C)
Industrial: 14 $^{\circ}$ F to 122 $^{\circ}$ F (-10 $^{\circ}$ C to 50 $^{\circ}$ C)

Rating/Material:

IP69K (IP66 with RJ45 option)
AISI 304 Stainless Steel

Weight:

6.25 lb (2.84 kg)

Warranty:

Two-year limited

Approvals:

NTEP 19-021, Class III/IIIL, 10,000 d
Measurement Canada AM-6121C
OIML R76 2006 A NL1 19.56R3
NOM
EU Eval Certificate TC11562
CE Listed
UKCA
cULus
NMI

Approvals



Measurement
Canada
Approved



National
Measurement
Institute

Standard Features

- Graphical, LCD color display with configurable softkeys
- Numeric, tactile keypad for scale operations, numeric entry and navigation
- Multi-language operation and text entry
- Formattable tickets
- Battery backed time and date
- Multiple communication ports
- 20 setpoints, 27 configurable types
- Fieldbus communication using Rice Lake's SCT-2200 modules and RS-485 port
- Built-in web server for remote access, systems integration and data monitoring
- Built-in Truck In/Out application
- Built-in batch presets
- Four onboard configurable digital I/O points, TTL logic
- Continuous/demand serial scale input
- Multi-range/interval

Options

- Analog output: 16-bit resolution, 0 to 10 VDC, 0 to 20 mA, 4 to 20 mA
- Relay card
- Dual serial card
- RJ45 Ethernet connector

Note: IP Rating is IP66 with RJ45 option. Rating is valid only when the cover is in place, not in use.

682 Synergy Series

Digital Weight Indicator

INDICATORS /
CONTROLLERS

Part Number/Price

Part #	Description	Est. Weight	Price
115-230 VAC			
193155†	682 Plus indicator, LCD display, US power cord	7 lb	\$1,175.00
193156††	682 Plus indicator, LCD display, EU power cord	7 lb	\$1,175.00
207348†††	682 Plus indicator, LCD display, UK power cord	7 lb	\$1,175.00
207349††††	682 Plus indicator, LCD display, AU power cord	7 lb	\$1,175.00
9-36 VDC			
193157	682 Plus indicator, LCD display	7 lb	\$1,300.00
With External RJ45 Connector*			
207354†	682 Plus indicator, LCD display, 115 to 230 VAC with RJ45, US power cord	7 lb	\$1,350.00
207355††	682 Plus indicator, LCD display, 115 to 230 VAC with RJ45, EU power cord	7 lb	\$1,350.00
207356†††	682 Plus indicator, LCD display, 115 to 230 VAC with RJ45, UK power cord	7 lb	\$1,350.00
207357††††	682 Plus indicator, LCD display, 115 to 230 VAC with RJ45, AU power cord	7 lb	\$1,350.00

*IP rating is IP66 with RJ45 option



† US plug (NA) - Type B



†† Euro Plug - Type E



††† BS1363 (UK) - Type G



†††† AS 3112 (Australian) - Type I

Options/Accessories

Part #	Description	Price
195084	Analog output	\$360.00
211709	Relay board	\$360.00
211710	Serial output	\$360.00
151099	Panel Mount	\$215.00
211701	Replacement CPU	\$545.00
223864	Knob, stainless steel M6 x 1.0 inch	\$15.00
194477	Parts kit	\$33.50
Fieldbus		
182592	Fieldbus, SCT-2200, PROFINET module	\$700.00
194343	Fieldbus, SCT-2200, Ethernet TCP/IP and Wi-Fi	\$620.00
182593	Fieldbus, SCT-2200, PROFIBUS® module	\$425.00
182591	Fieldbus, SCT-2200, EtherNet/IP™ module	\$700.00
182596	Fieldbus, SCT-2200, DeviceNet® module	\$625.00
182598	Fieldbus, SCT-2200, EtherCAT module	\$620.00
182597	Fieldbus, SCT-2200, CANopen module	\$620.00
196694	Fieldbus, SCT-2200, Modbus TCP module	\$675.00
182599	Cable with RJ45 plugs, 6 in length	\$15.00
212772	Fieldbus, SCT-2200, PROFIBUS module	\$425.00

Dimensions

682 Synergy Series			
A	10.00 in (254 mm)	E	11.60 in (295 mm)
B	9.50 in (241 mm)	F	3.50 in (89 mm)
C	8.60 in (218 mm)	G	4.00 in (102 mm)
D	6.00 in (152 mm)		

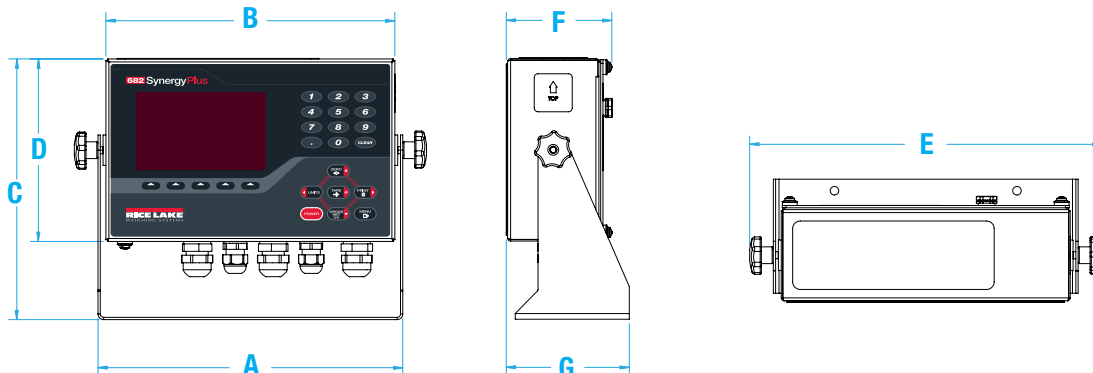

680HE Synergy Series

Hostile Environment Digital Weight Indicator



Approvals



Measurement
Canada
Approved



Part Number/Price

Part #	Description	Est. Weight	Price
197177	680HE Plus indicator, 115 to 230 VAC	6.25 lb (3 kg)	\$2,170.00
199574	680HE Plus indicator, 115 to 230 VAC with external RJ45	6.25 lb (3 kg)	\$2,300.00

Options/Accessories

Part #	Description	Price
195084	Analog output option card	\$360.00

Dimensions

680HE Synergy Series			
A	12.50 in (318 mm)	D	13.00 in (330 mm)
B	10.50 in (267 mm)	E	8.00 in (203 mm)
C	6.30 in (160 mm)		

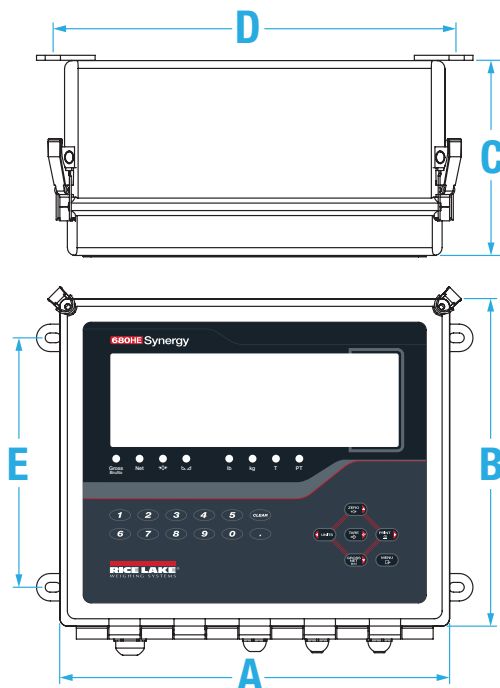

Standard Features

- LED display
- Battery backed time and date
- Full numeric keypad
- Multiple communication ports
- Eight setpoints, 22 configurable types
- Numeric keyed entry for tare and setpoint entry
- Formattable tickets
- Four onboard configurable digital I/O points, TTL logic
- Local/remote

Options

- Ethernet bulkhead connector
- Analog output: 16-bit resolutions, 0 - 10 VDC, 0 - 20 mA, 4 - 20 mA

Specifications

Power:

Line voltages: 100 to 240 VAC
Frequency: 50/60 Hz

Power Consumption:

12 W (AC) with one 350 ohm load cell, 30 W max

Excitation Voltage:

10 VDC (± 5 VDC), 8 \times 350 ohm or 16 \times 700 ohm load cells

Analog Signal Input Range:

-0.5 mV/V to +7 mV/V

Analog Signal Sensitivity:

1 μ V/graduation recommended

A/D Sample Rate:

6.25 to 120 Hz, software selectable

Resolution:

Internal: 8,000,000 counts
Display: 100,000

System Linearity:

Within 0.01% full scale

Digital I/O:

Four configurable I/O-5 V logic

Communication Ports:

Two full-duplex RS-232
RS-485/422 (five-wire)
Micro USB (device)
Ethernet TCP/IP (10/100)

Annunciators:

Eight LED annunciators

Display:

Six 2.5 in tall, seven-segment digits

Keys/Buttons:

Flat membrane panel, tactile feel
(18 buttons)

Dimensions:

(L \times W \times H)
12.50 \times 6.30 \times 10.50 in
(318 \times 160 \times 267 mm)

Temperature:

Certified: 14 $^{\circ}$ F to 104 $^{\circ}$ F (-10 $^{\circ}$ C to 40 $^{\circ}$ C)
Operating: 14 $^{\circ}$ F to 122 $^{\circ}$ F (-10 $^{\circ}$ C to 50 $^{\circ}$ C)

Rating/Material:

IP66, FRP

Weight:

7.9 lb (3.5 kg)

Warranty:

Two-year limited

EMC Immunity:

10 V/m

Approvals:

NTEP 19-021, Class III/IIIL, 10,000 d
Measurement Canada AM-6121C
CE Marked
UKCA
cULus Listed
IEC

INDICATORS /
CONTROLLERS

720i™ Series

Programmable Digital Weight Indicator/Controller

INDICATORS /
CONTROLLERS



Approvals



Measurement
Canada
Approved



Standard Features

- LCD display
- Four softkeys
- Truck In/Out, 1,000-ID memory (PCE software version)
- 32 setpoints, 26 configurable types (Batch software version)
- Process control engine ProAction PCE define conditions and actions
- Data storage onboard, ProAction DBE user-defined
- Eight digital I/O (expandable)
- One option slot for pluggable options
- 20 auxiliary print formats
- Time and date
- Audit trail tracking and alibi storage
- Peak hold
- Rate of change
- Accumulator
- Multi-range/interval
- Local/remote
- Two full duplex serial ports
- Header for fiber-optic, Ethernet or USB



Panel Mount



CPU Enclosure

Specifications

Power:

Line voltages: 100 to 240 VAC
Frequency: 50 to 60 Hz
DC voltages: 12 to 24 VDC

Power Consumption:

25 W

Excitation Voltage:

10 VDC (± 5 VDC), 16×350 ohm or
 32×700 ohm load cells

Analog Signal Input Range:

-10 mV to +45 mV

Analog Signal Sensitivity:

0.3 μ V/graduation minimum at 7.5 Hz
1.0 μ V/graduation recommended

A/D Sample Rate:

7.5 to 960 Hz, software selectable

Resolution:

Internal: 8,000,000 counts
Display: 1,000,000

System Linearity:

$\pm 0.01\%$ full scale

Digital I/O:

Eight channels on CPU board;
optional 24-channel I/O

Communication Ports:

Two ports on CPU board support up to 115,200 bps
Port 2: Full duplex RS-232 with handshaking
Port 4: Full duplex RS-232, simplex 20 mA
Optional dual-channel serial expansion boards
Channel A: RS-232, RS-485, 20 mA
Channel B: RS-232, 20 mA

Display:

240 \times 64 pixel, transreflective LCD
Panel mount: 3.8 \times 1.2 in (96 \times 30 mm)
Universal: 5.3 \times 1.5 in (133 \times 39 mm)

Keys/Buttons:

Ten-key (panel mount) membrane panel
22-key (universal) membrane panel tactile feel

Temperature:

Certified: 14 °F to 104 °F (-10 °C to 40 °C)
Operating: 14 °F to 122 °F (-10 °C to 50 °C)

Rating/Material:

NEMA Type 4X/IP66
Stainless steel

Weight:

Universal enclosure: 9.5 lb (4.3 kg)
Panel Mount enclosure: 8.5 lb (3.9 kg)

Warranty:

Two-year limited

EMC Immunity:

3 V/m

Approvals:

NTEP CC 08-022, Class III/IIIL 10,000 d
Measurement Canada AM-5677C
Class III/IIHD 10,000d
CE Marked
UL/cUL Listed (universal)
UL/cUL Recognized (panel mount)

Part Number/Price

Part #	Description	Est. Weight	Price
PCE Software			
101230 †	720i Universal, 115 VAC	12 lb	\$2,045.00
103459 ††	720i Universal, 115 to 230 VAC, CE	12 lb	\$2,045.00
107708*	720i Universal, 12 to 24 VDC	12 lb	\$2,195.00
101229**	720i Panel Mount, 115 to 230 VAC	12 lb	\$2,045.00
119116**	720i Panel Mount, 115 to 230 VAC, CE	12 lb	\$2,045.00
107710*	720i Panel Mount, 12 to 24 VDC	12 lb	\$2,195.00
Batch Software			
115447 †	720i Universal, 115 VAC	12 lb	\$2,045.00
115448 ††	720i Universal, 115 to 230 VAC, CE	12 lb	\$2,045.00
115449**	720i Panel Mount, 115 to 230 VAC	12 lb	\$2,045.00

*DC/DC converter installed option, not UL approved

**Power cord sold separately



† US plug (NA) - Type B



†† Euro Plug - Type E

Options/Accessories

Part #	Description	Price
Option Cards		
67601	Digital I/O, 24-channel	\$325.00
67602	Analog output: selectable 0-10 V, 0-20 mA	\$395.00
67604	Serial, dual channel	\$425.00
Network Cards		
77142	Ethernet TCP/IP Port (replaces serial port 2)	\$545.00
71986	Ethernet TCP/IP module (installed in option slot)	\$455.00
206272	Wi-Fi 802.11 A/B (replaces serial port 2)	\$610.00
87803	EtherNet/IP™ interface	\$895.00
68540	PROFIBUS® DP interface	\$720.00
68541	DeviceNet® interface	\$720.00
Hardware		
15436	Power cord for Panel Mount NEMA Type 5-15 plug	\$18.00
105382	Power cord for Panel Mount CEE 7/7 plug	\$18.00
19369	Start/stop switch box	\$475.00
83569	Clear protective overlay (package of five)	\$95.00
118975	Mount kit to convert Universal to Panel - non-NEMA rated	\$245.00
101923	Remote relay box, does not include relay	\$495.00
Manuals & Software		
103121	Installation manual	\$25.00
Primary Component Parts		
106788	CPU board assembly with PCE firmware	\$1,295.00
195388	CPU board assembly with batching firmware	\$1,295.00
101244	LCD display (Panel Mount) transfective	\$245.00
102888	LCD display (Universal) transfective	\$245.00
101239	Display board (includes display for Panel Mount)	\$595.00
102887	Display board (w/o display for Universal)	\$495.00
67613	AC power supply 100 to 240 nominal, 25 watt	\$225.00
132791	DC/DC power supply 12 to 24VDC nominal, 25 watt	\$235.00
101256	Switch membrane for Panel Mount	\$145.00
101257	Switch membrane for Universal	\$145.00

To have your option factory installed, please specify when placing your order.

720i™ Series

Programmable Digital Weight Indicator/Controller

Dimensions

720i Panel Mount Display		
A	7.36 in (187 mm)	D 2.45 in (62 mm)
B	1.60 in (41 mm)	E 3.88 in (99 mm)
C	0.59 in (15 mm)	F 0.62 in (16 mm)
720i Panel Mount CPU Enclosure		
(L × W × H): 12.75 × 6.05 × 2.14 in (324 × 154 × 5 mm)		

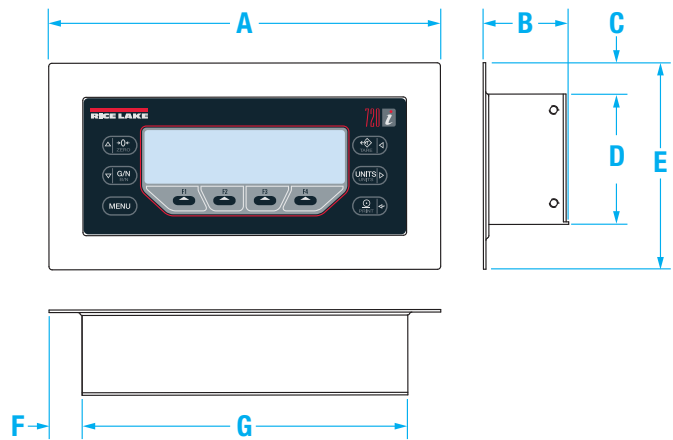

INDICATORS /
CONTROLLERS

Dimensions

720i Universal		
A	12.24 in (311 mm)	E 10.38 in (264 mm)
B	10.50 in (267 mm)	F 3.52 in (89 mm)
C	7.25 in (184 mm)	G 5.25 in (133 mm)
D	10.80 in (274 mm)	H 6.00 in (152 mm)
I	3.00 in (76 mm)	J 4.25 in (108 mm)
K	∅ 0.281 in (7 mm)	L ∅ 1.50 in (38 mm)

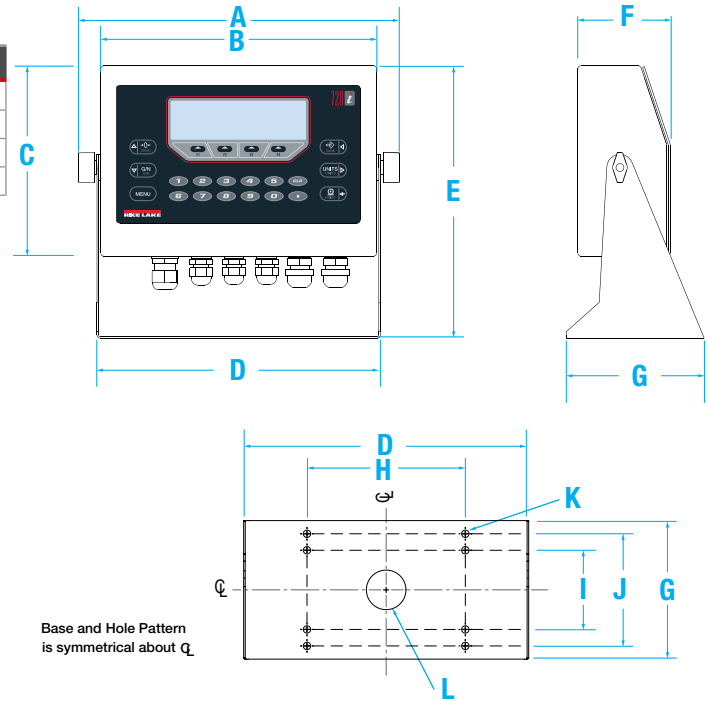

880/880 Plus Performance™ Series

Programmable Digital Weight Indicator/Controller



880 Plus Universal



880 Panel Mount

Specifications

Power:

Line voltages: 100 to 240 VAC
Frequency: 50/60 Hz
DC voltages: 12 to 24 VDC

Power Consumption:

AC: 15 W, DC: 20 W

Excitation Voltage:

10 VDC (± 5 VDC), 16 \times 350 ohm or
32 \times 700 ohm load cells

Analog Signal Input Range:

-45 mV to 45 mV

Analog Signal Sensitivity:

0.3 μ V/graduation minimum at 7.5 Hz;
1.0 μ V/graduation recommended

A/D Sample Rate:

7.5 to 960 Hz, software selectable

Resolution:

Internal: 8,000,000 counts
Display: 999,999

System Linearity:

$\pm 0.01\%$ full scale

Digital I/O:

Four I/O onboard, primary keys, pseudo functions, batching functions

(Optional) Analog Output:

Voltage output: 0–10 VDC
Load resistance: 1 k ohm minimum
Current output: 0–20 mA or 4–20 mA
External loop resistance: 500 W maximum

(Optional) Relay Board:

Four channel relay module, dry contact 3 A at
115 VAC, 3 A at 30 VDC

Communication Ports:

RS-232 full duplex or RS-485 half duplex;
USB micro A/B connector 2.0;
Ethernet TCP/IP

Annunciators:

Gross, net, center of zero, standstill, lb, kg, tare,
preset tare, multi-range/interval 1/2/3

Display:

LED, 0.56 in (14 mm), six-digit, 14-segment with
decimal or comma

Keys/Buttons:

Membrane panel, tactile feel

Dimensions:

(L \times W \times H)
Panel: 6.00 \times 4.95 \times 4.00 in (152 \times 126 \times 102 mm)
Universal: 9.87 \times 4.00 \times 9.38 in
(248 \times 102 \times 235 mm)

Temperature:

Certified: 14 °F to 104 °F (-10 °C to 40 °C)
Operating: 14 °F to 122 °F (-10 °C to 50 °C)

Rating/Material:

Panel display: stainless steel, NEMA Type 4X,
Type 12 and IP69K
Panel mount controller: Aluminum
Universal: stainless steel, IP69K

Weight:

Panel: 2.5 lb (1.2 kg);
Universal: 6.5 lb (2.9 kg)

Warranty:

Two-year limited

EMC Immunity:

10 V/m

Approvals:

NTEP 13-080 Class III/IIIL, 10,000 d
Measurement Canada AM-5931C
OIML R76/2006-A-NL1-18.23 Class III, 10,000 d
EU Test Certificate TC8463
CE Marked
cULus Listed (universal)
cULus Recognized (panel mount)

Approvals



Measurement
Canada
Approved



EU
LEGAL
FOR TRADE
CERTIFIED



Standard Features

- LED display
- USB device port connects directly to a PC
- Ethernet TCP/IP polled or continuous polled or continuous, server/client
- Built-in DIN-rail clips on controller box (panel mount)
- Display and controller can be separated up to 250 ft (panel mount)
- Hardware slot for one option card
- Operator functions through menu key for audit trail, preset tare, accumulator, time and date and setpoints
- Audit trail tracking for configuration and calibration changes. Password protection for user and configuration changes.
- 20 setpoints with latched batch engine or unlatched outputs
- Four onboard digital I/O channels
- Programmable ticket formats up to 1,000 characters for header text, gross, net, accumulator and setpoints
- Five-point linearization calibration
- Local/remote operation
- Multi-range or multi-interval weighing
- Filter settings for light, medium and heavy noise

Options

- Analog output
- Relay board
- Fieldbus connectivity
- Dual serial output (v4.00 and newer)
- 24-channel digital I/O (v4.00 and newer)
- Truck in/out program for 100 vehicle IDs
- Adapter plate for converting 310 and 520 panel mounts
- Panel mount kit for universal enclosure

880/880 Plus Performance™ Series

Programmable Digital Weight Indicator/Controller

INDICATORS /
CONTROLLERS

Part Number/Price

Part #	Description	Est. Weight	Price
880 Panel Mount AC Powered*			
177976	115 to 230 VAC, indicator	4 lb	\$1,350.00
177979	115 to 230 VAC, with analog output	4 lb	\$1,725.00
177980	115 to 230 VAC, with relay board	4 lb	\$1,725.00
177982	115 to 230 VAC, with EtherNet/IP™, single port	4 lb	\$2,000.00
177983	115 to 230 VAC, with PROFINET, single port	4 lb	\$2,000.00
177984	115 to 230 VAC, with Modbus/TCP, single port	4 lb	\$2,000.00
177985	115 to 230 VAC, with PROFIBUS® DP	4 lb	\$2,000.00
177986	115 to 230 VAC, with DeviceNet®	4 lb	\$2,000.00
179155	115 to 230 VAC, with EtherCAT	4 lb	\$2,000.00
880 Panel Mount DC Powered*			
177987	12 to 24 VDC, indicator	4 lb	\$1,450.00
880 Plus Universal AC Powered			
177989 †	115 VAC, indicator	8 lb	\$1,600.00
178496 †	115 VAC, with analog output	8 lb	\$1,950.00
178499 †	115 VAC, with relay board	8 lb	\$1,950.00
179147 †	115 VAC, with EtherNet/IP, single port	8 lb	\$2,225.00
179148 †	115 VAC, with PROFINET, single port	8 lb	\$2,225.00
179149 †	115 VAC, with Modbus TCP, single port	8 lb	\$2,225.00
179150 †	115 VAC, with PROFIBUS®	8 lb	\$2,225.00
179152 †	115 VAC, with DeviceNet	8 lb	\$2,225.00
179154 †	115 VAC, with EtherCAT	8 lb	\$2,225.00
177990 ††	115 to 230 VAC, indicator	8 lb	\$1,600.00
178497 ††	115 to 230 VAC, with analog output	8 lb	\$1,950.00
178500 ††	115 to 230 VAC, with relay board	8 lb	\$1,950.00
880 Plus Universal DC Powered			
178495	9 to 36 VDC, indicator	8 lb	\$1,700.00

*Power cord not included

Indicator part numbers contain the single port network card



† US plug (NA) - Type B



†† Euro Plug - Type E

Options/Accessories

Part #	Description	Price
Option Cards (5.5 in CPU only)		
179156	Analog output, 0 to 10 VDC, 0 to 20 mA, 4 to 20 mA	\$375.00
179157	Relay board, four dry contact outputs	\$350.00
197343**	Digital I/O, 24-channel TTL output	\$325.00
197347**	Serial ports, dual-channel RS-232/RS-485	\$375.00
Network Cards		
179158	EtherCAT interface	\$600.00
179159	EtherNet/IP™ interface, single port	\$600.00
179160	PROFINET interface, single port	\$600.00
179161	Modbus TCP/IP interface, single port	\$600.00
179162	DeviceNet® interface	\$600.00
179163	PROFIBUS® DP interface	\$600.00
205566	EtherNet/IP interface, dual port	\$805.00
205567	PROFINET interface, dual port	\$805.00
Hardware		
153660	Metrological sealing kit for panel mount	\$20.00
158404	Adapter plate for IQ310 and 520 replacement	\$75.00
177850	Mount kit, convert Universal to Panel, non-NEMA	\$255.00
180835	Universal backplate with RJ-45 receptacle	\$110.00
197724	Clear protective overlay for Universal (pack of 5)	\$85.00
15436	Power cord for Panel Mount, US plug	\$18.00
105382	Power cord for Panel Mount, Euro plug	\$18.00
223864	Knob, stainless steel M6 x 1.0 in	\$15.00

Options/Accessories

Part #	Description	Price
Cables		
152434	Cable, USB A to micro A shielded, 2 meters	\$55.00
156817	Cable, Ethernet RJ45 connectors, 1 meter	\$35.00
156806	Cable, USB A to A, 1 meter	\$35.00
156809	Cable, USB A to B, 1 meter	\$55.00
Manuals and Software		
152240	Operators manual	\$25.00
158387	Technical manual	\$25.00
Primary Component Parts		
131740	Overlay, Panel Mount, six-key	\$69.00
163986	Overlay, Universal with numeric keypad	\$69.00
131598	Display board	\$240.00
175603*	Power supply, 100 to 240 VAC	\$210.00
175604*	Power supply, 12 to 24 VDC	\$315.00
175109*	CPU board	\$575.00

* Design change in 2017 to 5.5in wide controller

** Requires version 4.0 firmware

To have your option factory installed, please specify when placing your order.

880/880 Plus Performance™ Series

Programmable Digital Weight Indicator/Controller

Dimensions

880 Panel Mount

A	6.00 in (152 mm)	C	4.95 in (126 mm)
B	4.00 in (102 mm)	D	0.58 in (14 mm) Bezel Depth

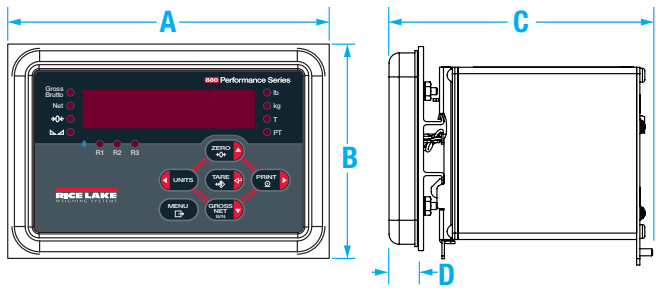

Dimensions

880 Universal

A	8.10 in (206 mm)	D	9.87 in (248 mm)
B	9.38 in (235 mm)	E	4.00 in (102 mm)
C	8.37 in (213 mm)	F	6.50 in (165 mm)

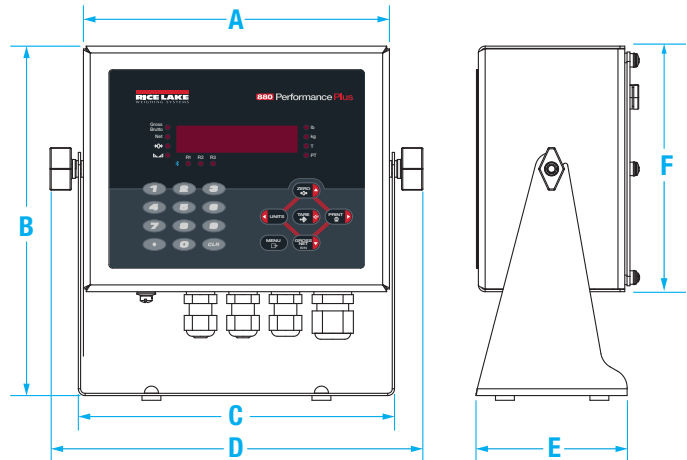

INDICATORS /
CONTROLLERS



Approvals



Measurement
Canada
Approved



EU
LEGAL
FOR TRADE
CERTIFIED



Standard Features

- Customizable backlit LCD graphical user interface
- 22 softkeys with 10 user-defined keys
- Tactile keypad for scale operations, numeric entry and navigation
- On-screen keyboard available during entry mode (or external keyboard)
- Supports 28 scales within 5 different scale types:
 - Analog load cell, multi-range/interval weighing
 - Total scale summing
 - Serial input scales
 - iQUBE² scales
 - Program scales
- 2 to 14 option slots for additional scale channels, serial ports, digital inputs and outputs, analog outputs and protocol interfaces
- iRite™ Programming Software
 - Customizable user applications with event-based functions
 - 150 built-in functions for application processes and data tables
- Four serial ports supporting RS-232, RS-485, 20mA
- USB Type A and B replaces Serial on Port 2 (USB model)
- Alibi memory captures serial port transmissions
- Configurable data stream format
- 100 setpoints, 27 configurable setpoint types
- Six digital I/O for control
- Four different enclosure types: universal, deep universal, wall mount, panel mount

Specifications

Power:

AC voltages: 100 to 240 VAC
Frequency: 50/60 Hz
DC voltages: 12 to 24 VDC

Power Consumption:

AC: 25 W (universal) or 65 W (others)
DC: 25 W for all models

Excitation Voltage:

10 VDC (± 5 VDC)
16 \times 350 ohm or 32 \times 700 ohm load cells
per A/D card

Analog Signal Input Range:

-45 mV to +45 mV

Analog Signal Sensitivity:

0.3 μ V/graduation minimum at 7.5 Hz
1.0 μ V/graduation recommended

A/D Sample Rate:

7.5 to 960 Hz, software selectable

Resolution:

Internal: 8,000,000 counts
Display: 1,000,000

System Linearity:

$\pm 0.01\%$ full scale

Digital I/O:

Six I/O channels on CPU board;
Optional 24-channel I/O expansion boards

Communication Ports:

Four ports on CPU board support up to 115,200bps
Port 1: Full duplex RS-232
Port 2: RS-232 with CTS/RTS; PS/2 keyboard
interface or USB type A and B connectors
Port 3: Full duplex RS-232, 20mA
Port 4: Full duplex RS-232, 2-wire RS-485, 20mA
Optional dual-channel serial expansion boards
Channel A: RS-232, RS-485, 20 mA
Channel B: RS-232, 20 mA

Display:

(W \times H)
4.6 \times 3.4 in (116 \times 86 mm),
320 \times 240 pixel
LCD module with adjustable contrast
Transmissive display
Transflective display (optional)

Keys/Buttons:

27-key membrane panel, tactile feel,
PS/2 or USB port for external keyboard connection

Temperature:

Certified: 14 °F to 104 °F (-10 °C to 40 °C)
Operating: 14 °F to 122 °F (-10 °C to 50 °C)

Rating/Material:

NEMA Type 4X, Type 12, IP66
Stainless steel

Weight:

Universal enclosure: 9.5 lb (4.3 kg)
Wall mount enclosure: 23.0 lb (10.4 kg)
Panel mount enclosure: 8.5 lb (3.9 kg)
Deep universal: 11 lb (5.0 kg)

Warranty:

Two-year limited

EMC Immunity:

10 V/m

Approvals:

NTEP 01-088, Class III/IIIL 10,000 d
Measurement Canada AM-5426,
Class III/III HD 10,000 d
OIML R76/2006-A-GB1-19.08
EU Test Certificate TC11584
cULus Listed (Universal, Deep Universal and
Wall Mount)
cULus Recognized (Panel Mount)
cULus Listed 508A (Custom Wall Mount)
CE Marked

920i® Series

Programmable Digital Weight Indicator



INDICATORS / CONTROLLERS

920i Universal Part Number/Price

Part #	Description	USB	Est. Weight	Price
Single-Channel				
67527 †	115 VAC		10 lb	\$3,395.00
115003 †	115 VAC	USB	10 lb	\$3,545.00
67615 †	230 VAC		10 lb	\$3,395.00
120062 †	230 VAC	USB	10 lb	\$3,545.00
69522 ††	230 VAC		10 lb	\$3,395.00
120074 ††	230 VAC	USB	10 lb	\$3,545.00
107713*	12 to 24 VDC, 25 watt		10 lb	\$3,545.00
120080*	12 to 24 VDC, 25 watt	USB	10 lb	\$3,695.00
Dual-Channel				
69767 †	115 VAC		10 lb	\$3,545.00
120086 †	115 VAC	USB	10 lb	\$3,695.00
69772 †	230 VAC		10 lb	\$3,545.00
120090 †	230 VAC	USB	10 lb	\$3,695.00
69774 ††	230 VAC		10 lb	\$3,545.00
120096 ††	230 VAC	USB	10 lb	\$3,695.00
No A/D Channel				
77790 †	115 VAC		10 lb	\$3,195.00
120100 †	115 VAC	USB	10 lb	\$3,345.00
77791 ††	230 VAC		10 lb	\$3,195.00
120104 ††	230 VAC	USB	10 lb	\$3,345.00

*DC/DC converter installed option, not UL approved



† US plug (NA) - Type B



†† Euro Plug - Type E

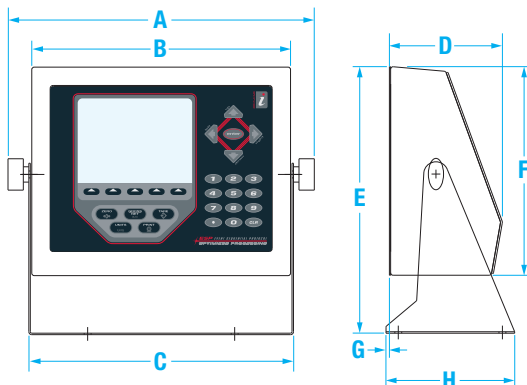

Dimensions

920i Universal					
A	12.50 in (318 mm)	D	4.61 in (117 mm)	G	0.14 in (3.5 mm)
B	10.56 in (268 mm)	E	10.87 in (276 mm)	H	5.25 in (206 mm)
C	10.90 in (277 mm)	F	8.50 in (216 mm)		

920i Deep Universal Part Number/Price

Part #	Description	USB	Est. Weight	Price
Single-Channel				
82455 †	115 VAC		12 lb	\$3,695.00
115004 †	115 VAC	USB	12 lb	\$3,795.00
82457 †	230 VAC		12 lb	\$3,695.00
120064 †	230 VAC	USB	12 lb	\$3,795.00
82459 ††	230 VAC		12 lb	\$3,695.00
120075 ††	230 VAC	USB	12 lb	\$3,795.00
107714*	12 to 24 VDC, 25 watt		12 lb	\$3,795.00
120081*	12 to 24 VDC, 25 watt	USB	12 lb	\$3,945.00
Dual-Channel				
82456 †	115 VAC		12 lb	\$3,795.00
120087 †	115 VAC	USB	12 lb	\$3,945.00
82458 †	230 VAC		12 lb	\$3,795.00
120092 †	230 VAC	USB	12 lb	\$3,945.00
82460 ††	230 VAC		12 lb	\$3,795.00
120097 ††	230 VAC	USB	12 lb	\$3,945.00
No A/D Channel				
93243 †	115 VAC		12 lb	\$3,445.00
120101 †	115 VAC	USB	12 lb	\$3,595.00
93244 ††	230 VAC		12 lb	\$3,445.00
120105 ††	230 VAC	USB	12 lb	\$3,595.00

*DC/DC converter installed option, not UL approved



† US plug (NA) - Type B



†† Euro Plug - Type E

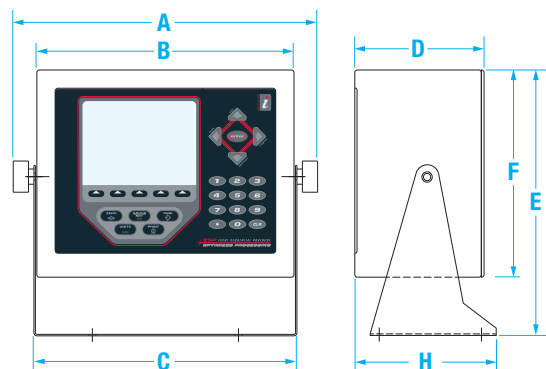

Dimensions

920i Deep Universal					
A	12.50 in (318 mm)	D	5.36 in (136 mm)	F	8.50 in (216 mm)
B	10.76 in (273 mm)	E	10.87 in (276 mm)	H	5.88 in (149 mm)
C	10.90 in (277 mm)				



920i Wall Mount Part Number/Price

Part #	Description	USB	Est. Weight	Price
Single-Channel				
69763 †	115 VAC		23 lb	\$4,295.00
115005 †	115 VAC	USB	23 lb	\$4,395.00
69765 †	230 VAC		23 lb	\$4,295.00
120066 †	230 VAC	USB	23 lb	\$4,395.00
72133 ††	230 VAC		23 lb	\$4,295.00
120078 ††	230 VAC	USB	23 lb	\$4,395.00
107715*	12-24 VDC, 25 watt		23 lb	\$4,395.00
120082*	12-24 VDC, 25 watt	USB	23 lb	\$4,545.00
Dual-Channel				
69770 †	115 VAC		23 lb	\$4,395.00
120088 †	115 VAC	USB	23 lb	\$4,545.00
69776 †	230 VAC		23 lb	\$4,395.00
120093 †	230 VAC	USB	23 lb	\$4,545.00
72134 ††	230 VAC		23 lb	\$4,395.00
120098 ††	230 VAC	USB	23 lb	\$4,545.00
No A/D Channel				
77794 †	115 VAC		23 lb	\$4,095.00
120102 †	115 VAC	USB	23 lb	\$4,195.00
77795 ††	230 VAC		23 lb	\$4,095.00
120106 ††	230 VAC	USB	23 lb	\$4,195.00
153346	115 VAC with start/stop switches		23 lb	\$4,445.00

*DC/DC converter installed option, not UL approved



† US plug (NA) - Type B



†† Euro Plug - Type E

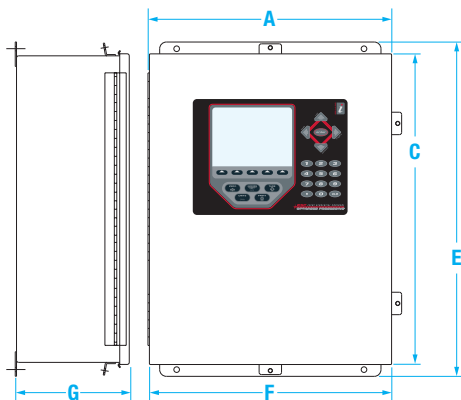

Dimensions

920i Wall Mount					
A	14.30 in (363 mm)	D	18.84 in (479 mm)	F	14.30 in (363 mm)
B	11.00 in (279 mm)	E	19.63 in (499 mm)	G	6.75 in (171 mm)
C	18.20 in (462 mm)				

920i Panel Mount Part Number/Price

Part #	Description	USB	Est. Weight	Price
Single-Channel				
69764 †	115 VAC		9 lb	\$3,395.00
115006 †	115 VAC	USB	9 lb	\$3,545.00
69766 †	230 VAC		9 lb	\$3,395.00
120069 †	230 VAC	USB	9 lb	\$3,545.00
72137 ††	230 VAC		9 lb	\$3,395.00
120079 ††	230 VAC	USB	9 lb	\$3,545.00
107716*	12-24 VDC, 25 watt		9 lb	\$3,545.00
120083*	12-24 VDC, 25 watt	USB	9 lb	\$3,695.00
Dual-Channel				
69771 †	115 VAC		9 lb	\$3,545.00
120089 †	115 VAC	USB	9 lb	\$3,695.00
69777 †	230 VAC		9 lb	\$3,545.00
120095 †	230 VAC	USB	9 lb	\$3,695.00
72138 ††	230 VAC		9 lb	\$3,545.00
120099 ††	230 VAC	USB	9 lb	\$3,695.00
No A/D Channel				
77792 †	115 VAC		9 lb	\$3,195.00
120103 †	115 VAC	USB	9 lb	\$3,345.00
77793 ††	230 VAC		9 lb	\$3,195.00
120107 ††	230 VAC	USB	9 lb	\$3,345.00

*DC/DC converter installed option, not UL approved



† US plug (NA) - Type B



†† Euro Plug - Type E

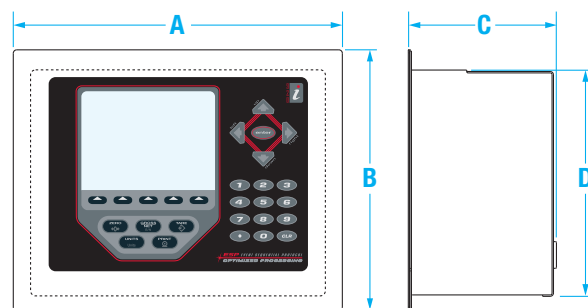

Dimensions

920i Panel Mount			
A	11.56 in (294 mm)	C	5.20 in (132 mm)
B	9.16 in (233 mm)	D	7.95 in (202 mm)

INDICATORS / CONTROLLERS

920i® Series

Programmable Digital Weight Indicator

To have your option factory installed, please specify when placing your order.

Options/Accessories

Part #	Description	Price
Option Cards		
68532	A/D, single-channel	\$395.00
68533	A/D, dual-channel	\$525.00
67601	Digital I/O, 24-channel TTL output	\$325.00
67602	Analog output: selectable 0-10 V, 0-20 mA	\$395.00
103138	Analog output, dual-channel 0-10 V, 0-20 mA	\$625.00
67604	Serial port card, dual-channel, RS-232 and RS-485	\$425.00
87697	Analog input +/-10 VDC, 0-20 mA and thermocouple	\$725.00
Network Cards		
65383	Ethernet thin server (external)	\$397.00
71986	Ethernet TCP/IP 10/100 module (internal)	\$455.00
206271	Wireless LAN module 802.11 b/g	\$670.00
87803	EtherNet/IP™ interface	\$895.00
68540	PROFIBUS® DP interface	\$720.00
187816	PROFINET IO interface	\$895.00
68541	DeviceNet® interface	\$720.00
103136	ControlNet® interface	\$1,080.00
Expansion Cards		
69782	Two-slot expansion board (wall mount)	\$395.00
71743	Two-slot expansion board (panel mount and deep universal)	\$395.00
180047	Two-slot expansion board (panel mount, DC powered)	\$395.00
179488	Two-slot expansion board (wall mount DC powered)	\$395.00
69783	Six-slot expansion board (wall mount)	\$495.00
Hardware		
83569	Clear protective overlay (package of 5)	\$95.00
70056	Cable, DB9M to DB9F, Straight Cable	\$40.00
77788	Fiber optic board, installed in 920i	\$235.00
92777	Filter, PreVent™ vent kit PG 7 cord grip	\$35.00
19368	Start/stop controls without box, for use on wall mount	\$475.00
19369	Start/stop switch with FRP box	\$475.00
93359	Keyboard, QWERTY PS/2 connector	\$165.00
Manuals and Software		
69781	iRev™ scale software	\$95.00
72809	Interchange® database software	\$325.00
67887	Additional installation manual	\$55.00
67888	Additional programming reference	\$55.00

Primary Component Parts

Part #	Description	Price
Boards		
186272***	CPU board assembly for LED backlight, (blue color)	\$1,725.00
186273***	Display board, LED back light, transmissive	\$395.00
186274***	Display board, LED back light, transreflective	\$395.00
206696***	Display kit (186273) and retrofit cable (207045)	\$425.00
Power Supply		
67613	AC power supply, 25 watt for universal	\$225.00
71333	AC power supply, 65 watt for deep, panel and wall mount	\$295.00
132791	Power supply 12 to 24VDC, 25 watt	\$235.00
Membrane		
66502	Switch panel membrane	\$125.00

***Design change in 2018 to LED backlight display.
CCFL backlight displays are no longer available.

The LED backlight display can be used with green CPU board Rev N or older by replacing the power supply cable, see Tech Bulletin PN 189640 for compatibility details. There is a generic retrofit PN 207045 for the existing power supply cable or a new power supply cable can be installed. Universal 186464 (AC) 186464 (DC); Deep universal 186278 (AC) 187603 (DC); Panel 186278 (AC) 187603 (DC); Wall 186760 (AC) 188345 (DC); Two-slot expansion for wall 188716 (AC) 189424 (DC); Two-slot expansion panel for deep universal 188717 (AC) 189425 (DC); Six-slot expansion for wall 188774 (AC).

Miscellaneous Parts

Part #	Description	Price
Cables for Digital I/O		
70780	50-pin flat ribbon, 24 in	\$95.00
93577	50-pin flat ribbon, 31 in	\$75.00
94384	50-pin flat ribbon, 50 in	\$95.00
70779	50-pin round ribbon with cord grip, 60 in	\$195.00
72442	50-pin round ribbon without cord grip, 60 in	\$195.00

Cables and Receptacles

Part #	Connector Type		Length	Price
USB Cables (Connector is a male plug)				
79074	A UNSEALED	B UNSEALED	2 m	\$35.00
124700	A SEALED	B SEALED	3 m	\$125.00
126477	A SEALED	A UNSEALED	3 m	\$545.00
124701	A SEALED	B UNSEALED	3 m	\$745.00
124702	B SEALED	A UNSEALED	3 m	\$675.00
USB Receptacles (Receptacle is a socket)				
126476*	A SEALED	A UNSEALED	0.5 m	\$125.00
124703*	A SEALED	B UNSEALED	0.5 m	\$125.00
124704*	B SEALED	B UNSEALED	0.5 m	\$125.00
125998*	A SEALED	FIVE-PIN Internal to 920i	0.28 m	\$125.00
125999*	B SEALED	FIVE-PIN Internal to 920i	0.28 m	\$125.00
Ethernet Cables				
124706	RJ-45 SEALED	RJ-45 SEALED	3 m	\$625.00
124707	RJ-45 SEALED	RJ-45 UNSEALED	2 m	\$125.00
Ethernet Receptacles (Receptacle is a socket)				
176789*	RJ-45 SEALED		0.75 m	\$145.00
172734*	RJ-45 SEALED		0.5 m	\$90.00
126353*	RJ-45 SEALED		0.28 m	\$125.00
Cable and Receptacle Accessories				
124695	Panel plug 1.125 in diameter			\$15.00
124694	Cover for sealed receptacles			\$25.00
124689	Cover for flash driver mounts on sealed receptacle			\$45.00
195607	USB Flash Drive 8GB			\$9.00

*These options require a milled back plate

Unsealed Connectors

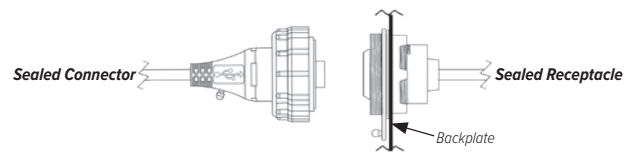

1280 Enterprise™ Series

Programmable Digital Weight Indicator



Specifications

Power:

AC voltages: 100 to 240 VAC; 50/60 Hz
DC voltages: 11 to 30 VDC

Power Consumption:

60W

Excitation Voltage:

10 VDC (± 5 VDC)
16 \times 350 ohm or 32 \times 700 ohm load cells
per A/D card

Analog Signal Input Range:

-60 mV to 60 mV

Analog Signal Sensitivity:

0.3 μ V/graduation minimum at 7.5 Hz to 120 Hz
1.0 μ V/graduation recommended

A/D Sample Rate:

7.5 to 960 Hz, software selectable

Resolution:

Internal: 8,000,000 counts
Display: 1,000,000

System Linearity

$\pm 0.01\%$ full scale

Digital I/O:

Eight I/O channels on CPU board
Optional 24-channel I/O expansion boards

Communication Ports:

Port 1 and 2
RS-232: Full duplex
RS-422/485: Half or full duplex
Baud rate: 1200 to 115200
Port 3: USB 2.0 Device (Micro)
USB host: (2) Type A connectors max 500 mA
Ethernet: Wired 10/100 Auto-MDX
Ethernet: Wireless 802.11 b/g/n 2.4GHz

Onboard:

Selectable filters: Three stage, Adaptive or Damping
Embedded Linux® OS
8 GB eMMC (system use)
1 GB DDR3 RAM
460 MB onboard database (SQLite) storage
Up to 32 GB micro-SD card (sold separately)

Display:

Seven-inch, 800 \times 480 pixel, 500 or 1,000 NIT
Twelve-inch, 1280 \times 800 pixel, 1,500 NIT

Keys/Buttons:

22-key membrane panel, tactile buttons, on-screen keyboard for text and numeric entry, USB port for flash drive, keyboard and printer

Temperature:

Certified: 14 °F to 104 °F (-10 °C to 40 °C)
Operating: -4 °F to 131 °F (-20 °C to 55 °C)

Rating/Material:

Universal: IP69K
Wall Mount: IP66
Panel Mount: IP69K, NEMA Type 4X and 12
Stainless steel 304 enclosure

Weight:

Universal enclosure: 11 lb (4.9 kg)
Panel mount enclosure: 8 lb (3.6 kg)
Wall mount enclosure: 23 lb (10.4 kg)
Panel mount 7 in touch-only: 7 lb (3.1 kg)
Panel mount 12 in touch-only: 10 lb (4.5 kg)

Warranty:

Two-year limited

EMC Immunity:

10 V/m

Approvals:

NTEP 15-001/Class III/IIIL 10,000d
Measurement Canada AM-5980C,
Class III/III HD 10,000d
OIML R76/2006-A-NL1-19.23 Class III/IIIL 10,000d
OIML R61-1/2017 TC8596
cULus Listed (Universal, Wall Mount)
cULus Recognized (Panel Mount)
CE Marked

Approvals



Measurement
Canada
Approved



Standard Features

- Customizable color touchscreen with graphical user interface
- User-defined softkeys, icons and graphics
- Tactile keypad for scale operations, numeric entry and navigation
- On-screen keyboard available during entry mode (or external keyboard)
- Built-in web server for remote access, systems integration and data monitoring
- Multi-language operation and text entry
- Supports eight scales within five different kinds:
 - Analog load cell, multi-range/interval weighing
 - Total scale summing
 - Serial input scales
 - iQUBE³ and iQUBE² scales
 - Program scales
- Six smart card slots for additional scale channels, serial ports, digital inputs and outputs, analog outputs and protocol interfaces
- iRite™ Programming Software
 - Five built-in applications: Truck In/Out, recipe storage, filling/dosing, counting, checkweighing
 - Customizable user programs with event-based functions
 - 150 built-in functions for common processes and data tables
 - Customize and transfer data via email, FTP server and networked printers
 - Display data with line charts or bar graphs
 - iRite reporting of iQUBE alerts
- Email, USB, Ethernet TCP/IP, Wi-Fi Direct®, two serial ports RS-232 or RS-485
- Alibi memory captures serial port transmissions
- Four configurable data-stream formats for PC, printers and remote displays
- 100 setpoints, 18 configurable setpoint types
- Eight digital I/O for control and pulse count
- Three different enclosure types: universal with tilt stand, panel mount and wall mount

INDICATORS /
CONTROLLERS

1280 Enterprise™ Series

Programmable Digital Weight Indicator



7-inch model with keypad



7-inch touch-only model



12-inch touch-only model

INDICATORS / CONTROLLERS

Numeric Keypad Models:

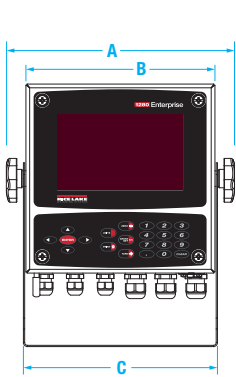

1280-2

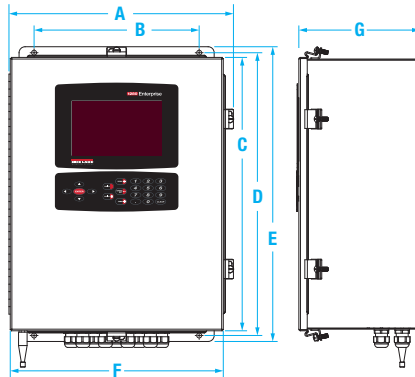
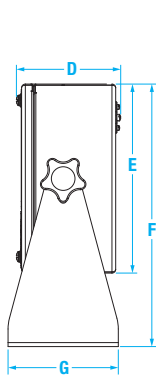

1280-3

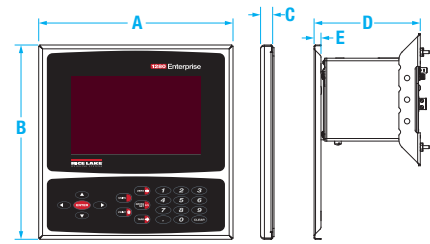

1280-4

Dimensions

Universal (1280-2)			
A	10.86 in (276 mm)	E	9.00 in (229 mm)
B	9.00 in (229 mm)	F	12.50 in (318 mm)
C	9.24 in (235 mm)	G	5.25 in (133 mm)
D	4.97 in (126 mm)		

Wall Mount (1280-3)			
A	14.92 in (379 mm)	E	19.64 in (499 mm)
B	11.00 in (279 mm)	F	14.20 in (361 mm)
C	18.22 in (463 mm)	G	8.08 in (205 mm)
D	18.84 in (479 mm)		

Panel Mount (1280-4)			
A	9.00 in (229 mm)	D	5.34 in (136 mm)
B	9.00 in (229 mm)	E	0.32 in (8 mm)
C	0.58 in (15 mm)		

Touch-only Models:

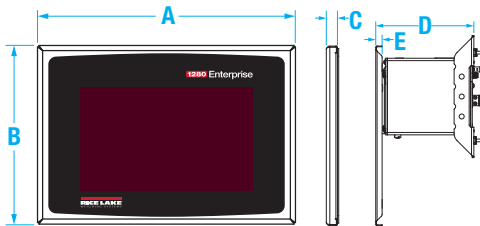

1280-5

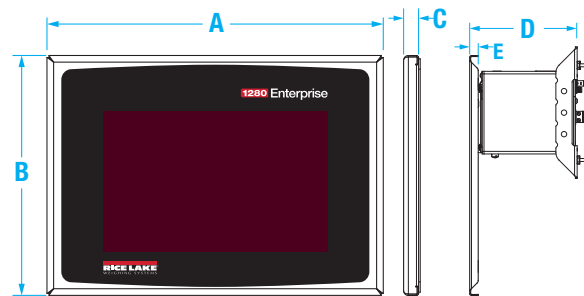

1280-6

Dimensions

7-inch Touch-only (1280-5)			
A	9.00 in (229 mm)	D	5.34 in (136 mm)
B	6.22 in (158 mm)	E	0.32 in (8 mm)
C	0.58 in (15 mm)		

12-inch Touch-only (1280-6)			
A	14.00 in (356 mm)	D	5.34 in (136 mm)
B	10.00 in (254 mm)	E	0.32 in (8 mm)
C	0.58 in (15 mm)		

1280 Enterprise™ Series

Programmable Digital Weight Indicator

INDICATORS / CONTROLLERS

Part Number/Price

Part #	Description	Power	Display	Option Installed	Price
Universal Enclosure with 500 NIT Display (1280-2)					
171427 †	1280 Universal	115 VAC	500 NIT	Single Scale Card	\$3,850.00
171441 ††	1280 Universal	100 to 240 VAC	500 NIT	Single Scale Card	\$3,850.00
171662 †	1280 Universal	115 VAC	500 NIT	Dual Scale Card	\$4,050.00
172188 ††	1280 Universal	100 to 240 VAC	500 NIT	Dual Scale Card	\$4,150.00
Panel Mount Enclosure with 500 NIT Display (1280-4)					
171663	1280 Panel Mount	100 to 240 VAC	500 NIT	Single Scale Card	\$3,725.00
172186	1280 Panel Mount	100 to 240 VAC	500 NIT	Dual Scale Card	\$3,950.00
Wall Mount Enclosure with 500 NIT Display (1280-3)					
173673 †	1280 Wall Mount	115 VAC	500 NIT	Single Scale Card	\$4,250.00
174143 ††	1280 Wall Mount	100 to 240 VAC	500 NIT	Single Scale Card	\$4,250.00
174144 †	1280 Wall Mount	115 VAC	500 NIT	Dual Scale Card	\$4,550.00
174145 ††	1280 Wall Mount	100 to 240 VAC	500 NIT	Dual Scale Card	\$4,550.00
Wall Mount Enclosure with 1000 NIT Display (1280-3)					
172184 †	1280 Wall Mount	115 VAC	1,000 NIT	Single Scale Card	\$4,350.00
172185 ††	1280 Wall Mount	100 to 240 VAC	1,000 NIT	Single Scale Card	\$4,350.00
206563 †	1280 Wall Mount	115 VAC	1,000 NIT	Dual Scale Card	\$4,550.00
172187 ††	1280 Wall Mount	100 to 240 VAC	1,000 NIT	Dual Scale Card	\$4,650.00
Touch-only 7 inch with 500 NIT Display (1280-5)					
186618	1280 Touch-only 7 in	100 to 240 VAC	500 NIT	Single Scale Card	\$3,750.00
Touch-only 12 inch with 1500 NIT Display (1280-6)					
186465	1280 Touch-only 12 in	100 to 240 VAC	1,500 NIT	Single Scale Card	\$4,375.00



† US plug (NA) - Type B



†† Euro Plug - Type E



(Brazil) - Type N



††† BS1363 (UK) - Type G



†††† AS 3112 (Australian) - Type I

Model Reference Chart

Choose any options to best fit your application and we customize

ENCLOSURE TYPE	POWER TYPE	DISPLAY TYPE	CORD TYPE	OPTION CARDS <small>ALL SLOTS MUST BE FILLED</small>
<ol style="list-style-type: none"> Universal (1280-2) Panel (1280-4) Wall (1280-3) Touch-only Panel 7 in (1280-5) Touch-only Panel 12 in (1280-6) 	<ol style="list-style-type: none"> AC DC 	<ol style="list-style-type: none"> 500 NIT 7 in Universal 1000 NIT 7 in Universal 500 NIT 7 in Panel/Wall 1000 NIT 7 in Panel/Wall 1500 NIT 12 in Panel 	<ol style="list-style-type: none"> US Plug Universal Brazil Plug Universal Euro Plug Universal US Plug Wall Euro Plug Wall Brazil Plug Wall UK Plug Universal AU/NZ Plug Universal UK Plug Wall AU/NZ Plug Wall 	<ol style="list-style-type: none"> Blank <i>If no option, controller will need 6 blanks</i> Single A/D Scale Dual A/D Scale 24 Channel Digital I/O Dual Serial Channel 4-dry Contact Relay Single Analog Out Dual Analog Out Analog Out EtherNet/IP™ DeviceNet® PROFINET Modbus TCP PROFIBUS® DP EtherCat® PowerLink

1280 Enterprise™ Series

Programmable Digital Weight Indicator

INDICATORS /
CONTROLLERS

Single A/D Scale



Excitation Voltage:
10 VDC bipolar, 4 or 6 wire sensing
16 × 350 ohms per channel

Analog Input Signal:
-10 to +40 mV

Part #	Description	Price
220026	Single scale A/D	\$475.00
166957	A/D sealing kit	\$15.00

Dual A/D Scale



Excitation Voltage:
10 VDC bipolar, 4 or 6 wire sensing
8 × 350 ohms per channel

Analog Input Signal:
-10 to +40 mV

Part #	Description	Price
220027	Dual scale A/D	\$675.00
166957	A/D sealing kit	\$15.00

Digital I/O



24 channels, configurable as inputs or outputs
Inputs: 5 VDC max, active low; Outputs: 20 mA max per channel, active low; 5 VDC source available: 500 mA max

Part #	Description	Price
164684*	Digital I/O	\$350.00
170008	DIO adapter, includes 60 pin flat ribbon cable, 24 in	\$130.00
170009	DIO adapter, includes 60 pin round cable, 60 in	\$225.00
170736	DIO adapter, includes 60 pin cable and cord grip, 60 in	\$155.00

* 24 I/O ribbon cable required.

Dual Serial Channel



Two-channel, full duplex RS-232 with CTS/RTS, RS-485 or RS-422, 1200 to 115200 baud

Part #	Description	Price
164685	Dual serial channel	\$425.00

Single Analog Out



16 bit, voltage output 0 to 10 VDC, current output 0 to 20 mA, 4 to 20 mA

Part #	Description	Price
165366	Single analog out	\$375.00

Dual Analog Out



16 bit, voltage output 0 to 10 VDC, current output 0 to 20 mA, 4 to 20 mA

Part #	Description	Price
164686	Dual analog out	\$550.00

Relay Card

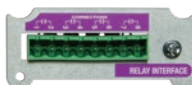

Relay four-dry contact, max current
3 A @ 30 VDC, 3 A @ 250 VAC

Part #	Description	Price
164689	Relay card	\$425.00

Analog Input



Analog Input Signal:
± 10 VDC, ± 100 mV, 0 to 20 mA

Part #	Description	Price
164687	Dual analog input	\$650.00

Data Exchange with PLC/DCS Systems

EtherNet/IP™



Part #	Description	Price
165792	EtherNet/IP, single port	\$620.00
208129	EtherNet/IP, dual port	\$805.00

DeviceNet®



Part #	Description	Price
165793	DeviceNet	\$620.00

PROFINET



Part #	Description	Price
165794	PROFINET	\$620.00

Modbus TCP



Part #	Description	Price
165796	Modbus TCP	\$620.00

PROFIBUS® DP



Part #	Description	Price
165795	PROFIBUS DP	\$620.00

EtherCAT®



Part #	Description	Price
179533	EtherCAT	\$620.00

1280 Enterprise™ Series

Programmable Digital Weight Indicator

Options/Accessories

To have your option factory installed, please specify when placing your order.

Part #	Description	Price
Manuals and Software		
167659	Technical Manual	\$35.00
72809	Interchange database software	\$325.00
164939	8 GB Micro SD card with SD and USB adapter	\$25.00
195607	USB flash drive, 1 GB	\$9.00
Extended Display Cable Length for Touch Only Models		
182600	Display cable for 7 in (500 NIT) touch-only, 5 ft length	\$130.00
182601	Display cable for 7 in (500 NIT) touch-only, 10 ft length	\$160.00
187489	Display cable for 7 in (1,000 NIT) touch-only, 10 ft length	\$160.00
180027	Display cable for 12 in touch-only, 5 ft length	\$160.00
180028	Display cable for 12 in touch-only, 10 ft length	\$160.00
Extended Touch Cable Length for Touch Only Models		
180744	Touch cable for touch-only, 5 ft length	\$105.00
180745	Touch cable for touch-only, 10 ft length	\$105.00

Primary Component Parts

Part #	Description	Price
Displays		
163400	7 in 500 NIT display	\$350.00
163399	7 in 1,000 NIT display	\$450.00
182992	12 in 1,500 NIT display	\$995.00
Boards		
179992	1280 main CPU board with fan plate	\$1,100.00
199157	1280, CPU AC power, extruded aluminum enclosure (replacement)	\$1,500.00
Power Supplies		
202512	AC power supply board	\$180.00
202514	DC power supply board	\$180.00
Overlays		
164121	Keypad, for panel and wall mount	\$75.00
164120	Touchscreen, for panel and wall mount	\$130.00
161731	Keypad, for universal	\$75.00
161730	Touchscreen, for universal	\$145.00
178498	Touchscreen, for 7 in touch-only panel mount	\$295.00
176126	Touchscreen, for 12 in touch-only panel mount	\$400.00
178161	Clear protective overlay display for 7 in display (pack of 5)	\$63.00
178163	Clear protective overlay keypad for 7 in display (pack of 5)	\$63.00

Cables and Receptacles

To have your option factory installed, please specify when placing your order.

Part #	Connector Type	Length	Price
USB Cables (Connector is a male plug)			
79074	A UNSEALED B UNSEALED	2 m	\$35.00
124700	A SEALED B SEALED	3 m	\$125.00
126477	A SEALED A UNSEALED	3 m	\$545.00
124701	A SEALED B UNSEALED	3 m	\$745.00
124702	B SEALED A UNSEALED	3 m	\$675.00
152434	A UNSEALED Micro A UNSEALED	2 m	\$55.00
USB Receptacles (Receptacle is a socket)			
176790 Panel Mount	A SEALED A UNSEALED	0.75 m	\$105.00
126476 Wall Mount	A SEALED A UNSEALED	0.5 m	\$125.00
172735 Universal	A SEALED A UNSEALED	0.25 m	\$90.00
Ethernet Cables			
72697	RJ-45 UNSEALED RJ-45 UNSEALED	2 m	\$40.00
124706	RJ-45 SEALED RJ-45 SEALED	3 m	\$625.00
124707	RJ-45 SEALED RJ-45 UNSEALED	2 m	\$125.00
Ethernet Receptacles (Receptacle is a socket)			
176789	RJ-45 SEALED	0.75 m	\$145.00
172734	RJ-45 SEALED	0.5 m	\$90.00
126353	RJ-45 SEALED	0.25 m	\$125.00
Cable and Receptacle Accessories			
124694	Cover for sealed receptacles		\$25.00
124689	Cover for flash driver mounts on sealed receptacle		\$45.00

INDICATORS / CONTROLLERS

Unsealed Connectors

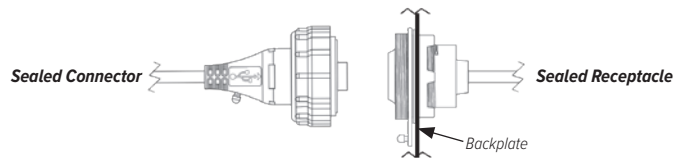

Relays and Racks

Input/Output Components



PN 45408
(6.10 × 1.20in)



PN 33206
(10.00 × 3.25 × 2.32in)

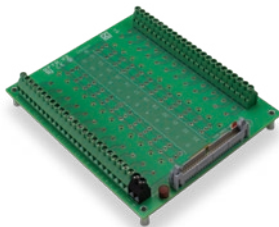

PN 33205
(7.50 × 6.25 × 2.32in)

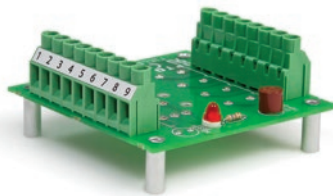

PN 15973
(3.25 × 3.25 × 2.32in)

INDICATORS /
CONTROLLERS

Relay Racks

OPTO 22 4-Channel		
15973	Four-channel relay rack	\$125.00
Dimensions		
A	B	C
3.25 in (83 mm)	3.25 in (83 mm)	2.32 in (59 mm)

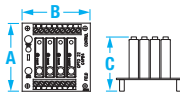

OPTO 22 4-Channel		
45408	Four-channel relay rack (non UL)	\$160.00
Dimensions		
A	B	C
1.20 in (30 mm)	6.11 in (155 mm)	2.32 in (59 mm)

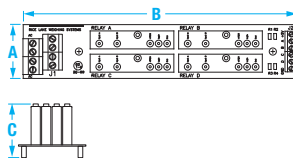

OPTO 22 16-Channel		
33206	16-channel relay rack, ribbon cable connection	\$395.00
Dimensions		
A	B	C
3.25 in (83 mm)	10.0 in (254 mm)	2.32 in (59 mm)

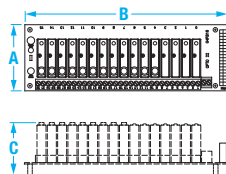

OPTO 22 24-Channel		
33205	24-channel relay rack, ribbon cable connection	\$372.00
Dimensions		
A	B	C
7.50 in (83 mm)	6.25 in (83 mm)	2.32 in (59 mm)

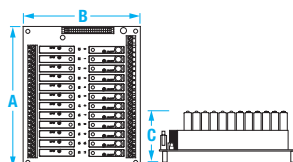

Part Number/Price

Part #	Description	Price
Input/Output Component		
43942	Allen-Bradley® multi-function relay with digital display	\$575.00
29616	Dayton multi-function relay	\$325.00
Other Relays		
15952	Eight-pin octal relay, AC/DC output, 10 A, 120 VAC coil	\$57.00
15960	Eight-pin octal relay, AC/DC output, 10 A, 6 VDC coil	\$30.00
15961	Eight-pin octal socket	\$21.00
70780	Cable, 50-pin flat ribbon for digital I/O, 24 in	\$95.00
70779	Cable, 50-pin round ribbon for digital I/O with cord grip, 60 in	\$195.00
72442	Cable, 50-pin round ribbon for digital I/O without cord grip, 60 in	\$195.00
93577	Cable, 50-pin flat ribbon for digital I/O, 31 in	\$75.00
94384	Cable, 50-pin flat ribbon for digital I/O, 50 in	\$95.00

Relays

Part #	Voltage	Description	Price
OPTO 22 1-Channel Input Relay			
15972	90 to 140 VAC	G4IAC5-L (N/O), yellow	\$50.00
36631	180 to 280 VAC/VDC	G4IAC5A (N/O), yellow	\$52.00
15969	10 to 32 VDC	G4IDC5 (N/O), white	\$50.00
OPTO 22 2-Channel Output Relay			
15971	115 VAC	G4OAC5 (N/O), black	\$50.00
22847	115/230 VAC	G4OAC5A5 (N/C), black	\$67.00
36632	115/230 VAC	G4OAC5A (N/O), black	\$52.00
15970	100 VDC	G4ODC5R, (N/O) dry contact, red	\$50.00
121345	60 VDC	G4ODC5, (N/O), red	\$50.00
22848	100 VDC	G4ODC5R5, (N/C) dry contact, red	\$77.00
Relay Boards Fixed Dry Contact Relay			
30549	2-channel 120 to 240 VAC or 30 VDC/5 A		\$175.00
15959	4-channel 120 to 240 VAC or 30 VDC/5 A		\$305.00
29615	Board, relay mounting 1-channel (requires DIN rail for mounting (non UL)		\$105.00
33207	Board, relay mounting 8-channel		\$200.00

Miscellaneous Parts

Part #	Description	Price
Cables for Digital I/O		
70780	50-pin flat ribbon, 24 in	\$95.00
93577	50-pin flat ribbon, 31 in	\$75.00
94384	50-pin flat ribbon, 50 in	\$95.00
70779	50-pin round ribbon with cord grip, 60 in	\$195.00
72442	50-pin round ribbon without cord grip, 60 in	\$195.00
170008	60-pin flat ribbon with 50-pin adapter, 24 in	\$130.00
170009	60-pin round with 50-pin adapter, 60 in	\$225.00
170736	60-pin round with 50-pin adapter and cord grip, 60 in	\$155.00
Opto 22 Misc.		
26834	Fuse, 1A 250V (for PN 15970 and PN 22848)	\$12.00
21735	Fuse, 4A 250V (for PN 15971, PN 22847 and PN 36632)	\$26.00
16478	Quencharc® arc suppressor	\$11.00
101923	FRP enclosure with Opto four-channel rack	\$495.00
99032	Adapter plate, for four-channel Opto rack 33490	\$5.25
155253	Board assembly, DWM IV, eight-channel, Opto 22 G4 series compatible, (non UL)	\$245.00



Approvals



Measurement
Canada
Approved

Dimensions

LaserLight3			
A	23.00 in (584 mm)	E	5.00 in (127 mm)
B	10.10 in (256 mm)	F	8.00 in (203 mm)
C	8.73 in (222 mm)	G	25.02 in (636 mm)
D	5.87 in (149 mm)		

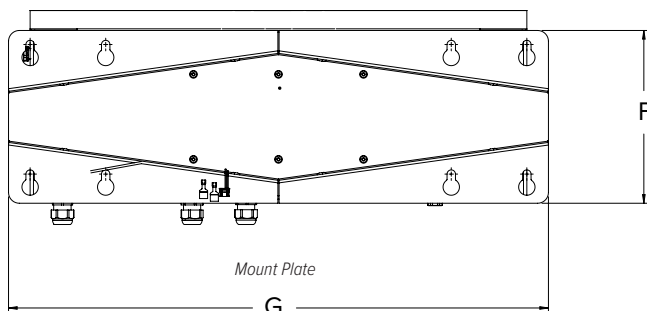
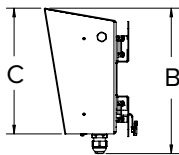
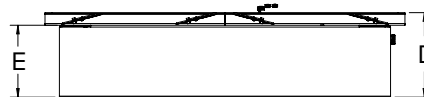
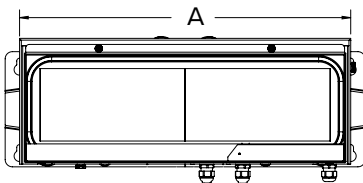

Standard Features

- Color display
- Displays six high-intensity digits up to 5 in height
- Adjustable daylight/night intensity
- Mirror mode (reverse image) function
- Durable weather tight enclosure with flip-down door
- Flat-wall mounted or add VESA or offset mount

Options

- Wireless LAN, Wi-Fi interface 802.11 a/b
- Wireless interface, pair of ConnexLink™ radios and mount
- Pole mount kit, VESA flat wall for 2 to 6 inch pole (W × H) 200 × 100 mm, six fasteners (M4 × 8 mm)
- Sunshade visor, 8-inch painted steel

Specifications

Power:

AC voltages: 100 to 240 VAC; 50/60 Hz

Power Consumption:

120 watt (120 VAC)

Excitation Voltage:

5 VDC, 8 × 350 ohm or 16 × 700 ohm load cells

Analog Signal Input Range:

-5 mV to +70 mV

Analog Signal Sensitivity:

0.3 μV/graduation minimum

1 μV/graduation recommended

A/D Sample Rate:

6.25 to 120 Hz, software selectable

Resolution:

Internal: 8,000,000 counts

Display: 1,000,000

System Linearity:

Within 0.01% full scale

Output Interface:

Ethernet TCP/IP, independently configurable echo port

Input Data Format:

Baud rate: 1200, 2400, 4800, 9600, 19200, 38400, 57600 and 115200 self-learning or configurable

Update:

Continuous or out-of-motion modes

Message interrupt mode

Digital I/O:

Four I/O read or set

5 V logic

Communication Ports:

Two full-duplex RS-232

RS-485/422 (two-wire or four-wire)

Micro USB (device)

Ethernet TCP/IP (10/100)

Wi-Fi

Display:

Bright, outdoor color LED lamps

128 × 32-pixel, 4 mm pitch

Decimal or comma indication

Weight display with units and mode

Message display

1, 2 or 4 lines

Maximum Viewing Distance:

4-inch character 100 ft (30 m)

5-inch character: 150 ft (46 m)

Viewing Angle:

160°

Character Format:

7 or 8 data bits; even, odd, or no parity;

1 or 2 stop bits

Keys/Buttons:

Zero, Gross/Net, Tare, Units, Print, Menu

Time:

Software enable, 12 or 24 hour format

Date:

Software enable, US or ISO format

Temperature:

Operating:

-40 °F to 120 °F (-40 °C to 49 °C)

Rating/Material:

IP66

Mild steel, powder-coated

Warranty:

Two-year limited

Approvals:

NTEP 22-096

Measurement Canada AM-6210C

LaserLight3™

Color Large-display Weight Indicator

Part Number/Price

Part #	Description	Est. Weight	Price
205780	LaserLight3 large-display weight indicator	20lb	\$2,495.00

Options/Accessories

Part #	Description	Price
212745	Pole mount kit, VESA flat-wall, 200 mm W x 100 mm H, 6 fasteners (M4 x 8 mm) for 2-6 inch pole	\$100.00
75856	Pole mount kit, 4-in flange style (24-in wide frame use with 4-8 in dia. pole)	\$280.00
208807	Sunshade, 8-in	\$135.00
209118	Wireless LAN, RS-232/Wi-Fi interface 802.11 a/b XPico module	\$250.00
212753	Wireless interface, pair of ConnexLink radios transceiver kit and mount	\$835.00

INDICATORS /
CONTROLLERS

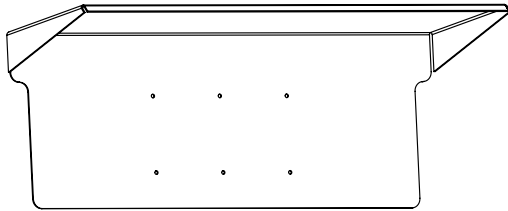

Sunshade
PN 208807

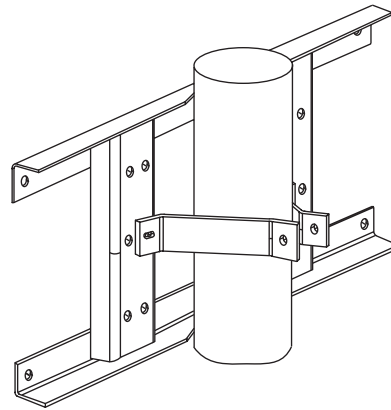

Flange pole mount kit
PN 75856

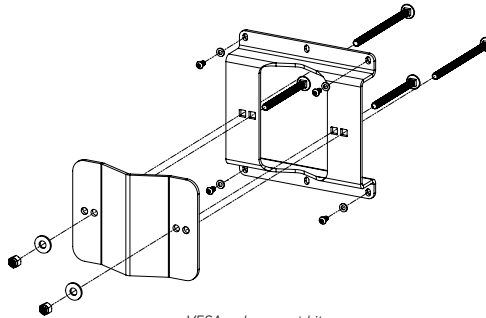

VESA pole mount kit
PN 212745

LaserLT-60 and LaserLT-100

Large-display Digital Weight Indicators



Standard Features

- LED Display
- Integrated five-key waterproof keypad
- Includes removable back wall mount bracket
- Up to four independent scales or four load cell inputs
- Quick menu for real and theoretical calibration
- Up to three calibration linearization points
- Semi-automatic and preset tare
- Two digital outputs for 13 setpoint types with timers to enable on and delay period
- Two digital inputs for operating keys remotely

Specifications

Power:

AC voltage: 100 to 240 VAC
DC voltage: 12 to 24 VDC

Excitation Voltage:

5 VDC, 120 mA, 16 × 350 ohm

Analog Signal Input Range:

± 39 mV

Analog Signal Sensitivity:

0.03 µV/graduation minimum
0.3 µV/graduation recommended

A/D Sample Rate:

Four channel A/D up to 200 Conv./sec. auto select

Resolution:

Internal: 1,500,000 counts
Display: 800,000

Digital I/O:

Two inputs: 12/24 VDC
Two outputs: 150 mA 48 VAC/150 mA 60 VDC

Communication Ports:

(1) RS-232, (1) RS-485

Display:

6-digit, 7-segment discrete red LED lamps, single width
2.4 in (60 mm) or 4 in (100 mm) digit
Decimal/comma indication in any position
Annunciators for NT, Stability, COZ
5 levels of intensity

Maximum Viewing Distance:

LaserLT-60: 2.4 in digit 75 ft (25 m)
LaserLT-100: 4 in digit 100 ft (30 m)

Keys/Buttons:

Five key, Zero (Down), Tare (Up), Mode (Right), Print (Enter), C (On/Off)

Temperature:

-40° F to 120° F (-40° C to 49° C)

Rating/Material:

304 stainless steel, IP68

Weight:

10 lb (4.5 kg)

Warranty:

One-year limited

Approvals:

NTEP CC 20-046 III/IIIL 10,000 d
Measurement Canada AM-6165C III/IIIL 10,000 d
CE Marked

Approvals



Measurement
Canada
Approved



Part Number/Price

Part #	Description	Price
197453	LaserLT-60, indicator with weighing functionality 2.4 in (60 mm) LED	\$1,380.00
197454	LaserLT-100, indicator with weighing functionality 4.0 in (100 mm) LED	\$1,765.00

Options/Accessories

Part #	Description	Price
185256	Mount bracket, 2 tilting side brackets for LaserLT-100	\$65.00
185258	Visor for LaserLT-100	\$165.00

Dimensions

Large Display Digital Weight Indicator			
LaserLT-60			
A	16.14 in (410 mm)	D	7.28 in (185 mm)
B	6.50 in (165 mm)	E	2.64 in (67 mm)
C	3.03 in (77 mm)	F	4.84 in (123 mm)
LaserLT-100			
A	16.93 in (430 mm)	D	7.63 in (194 mm)
B	7.28 in (185 mm)	E	2.52 in (64 mm)
C	2.52 in (64 mm)	F	3.98 in (101 mm)

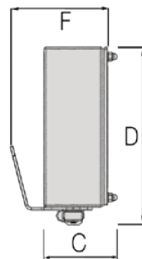
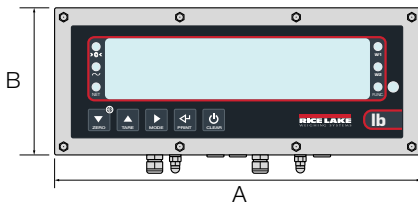

INDICATORS / CONTROLLERS

1280 Enterprise™ Series

User Programs



Standard Features

- Pre-programmed applications are built in or available as free downloads from www.ricelake.com/1280
- Applications are designed to carry out process-specific weighing tasks
- Utilize Rice Lake's iRite™ programming language to fully customize any application beyond existing functionality
- For use with all models of 1280 Enterprise Series (hardware requirements may apply)

INDICATORS / CONTROLLERS



Axle Weighing Program

1280 with custom programming interfaced with a short- or long-axle scale can direct each axle across the scale using traffic lights (optional).

- Short- or long-axle
- Auto or manual weighing types
- Weigh-out ticket format
- Weigh ticket with individual axle weight and total
- Inbound and transaction storage

Optional

- Remote print input
- Manual weighing short axle, long axle weigh-in and -out with axles

Suggested Hardware:

- PN 171427 1280 single channel A/D
- PN 81076 Epson TM-U220
- PN 101923 FRP box with 4-channel rack OPT022 (relays not included)
- PN 23146 traffic light kit
- PN 15971 AC output relays for above (2 needed)
- PN 167093 LaserLight2™ stop and go remote display

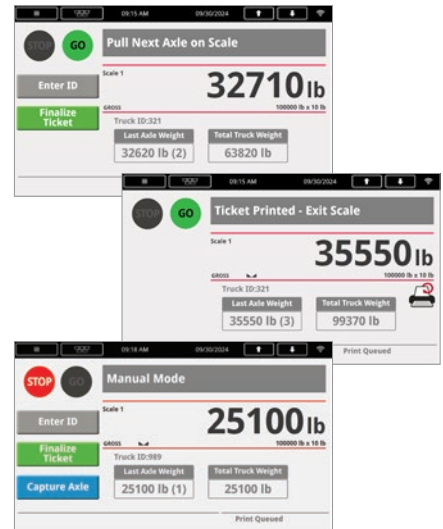

Truck In/Out Program

Truck In/Out programs offer advanced reporting through customer or truck reports including transaction database storage.

- Value swapping (on/off)
- Stored empty truck (tare) weights on/off
- Printed inbound/outbound tickets
- Customer reports by product or truck
- Tag, inbound, product, customer and transaction database storage

Optional

- Manual toggle of lights

Suggested Hardware:

- PN 171427 1280 single channel A/D
- PN 220027 1280 dual channel A/D for 3-scale
- PN 108425 iQUBE² 4-channel (additional 4-channel iQUBE² board PN 108433)
- PN 227157 iQUBE³ CPU Board, 4-channel, small poly (additional 4-channel iQUBE³ board PN 231373)
- PN 81076 Epson TM-U220 ticket printer
- PN 23113 Epson TM-U295 ticket printer
- PN 167093 LaserLight2 stop and go remote display

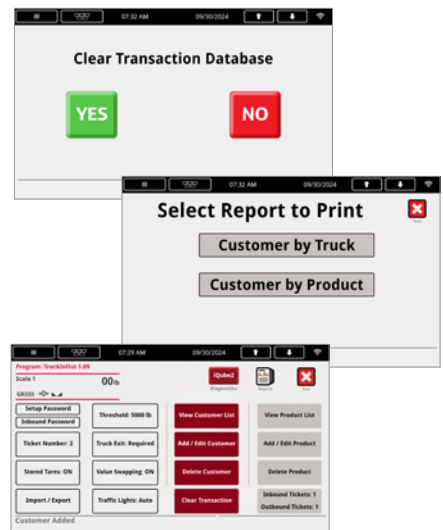
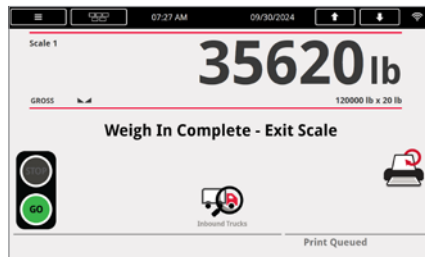



Static Checkweigher Program

Application for static checkweigher with a stored low and high weight associated with an ID. A digital output will be activated based on configuration parameters: over, under or accept. Stores the ID, weight, status and time/date in a database.

- Stored IDs with high/low weight
- Transaction storage
- Digital I/O for Over/Under/Accept values
- Ticket formatting
- Compatible with WeighVault®

Suggested Hardware:

- PN 171427 single channel 1280 universal
- PN 81076 TM-U220D tape printer (sold separately, PN 15547 25-pin communication cable)
- PN 225024 scanner kit QD2590
- PN 125546 WeighVault for CW90-90X and 1280

Password Protected Access to Setup

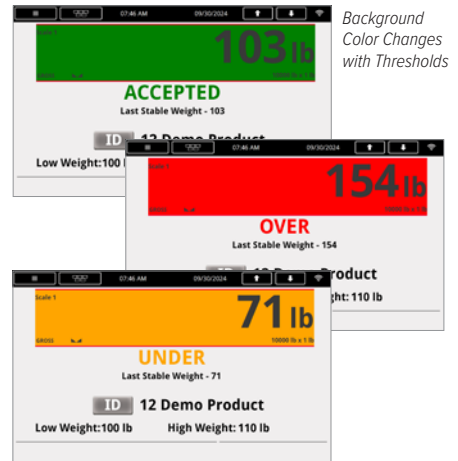

Background Color Changes with Thresholds



Counting Program

Ideal for piece counting and packaging applications, configuration for two scales. System only supports PRIMARY units.

- Supports two (2) scales, sampling and counting
- Part database
- Transaction storage
- Ticket formatting
- Compatible with WeighVault

Suggested Hardware:

- PN 171662 1280 dual channel A/D card
- PN 81076 TM-U220D tape printer (sold separately, PN 15547 25-pin communication cable)
- PN 125546 WeighVault for Counterpart and 1280

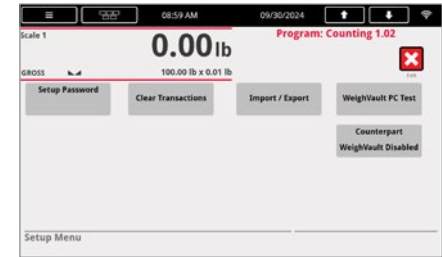
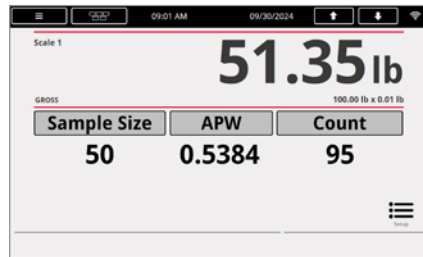

Configuration Menu Includes View of Weight Value



Filling/Dosing Program

Application for gross or net container filling, including auto-fill and discharge settings for single-scale systems.

- Auto fill, auto discharge
- Single scale
- Transaction storage
- Start/E-stop digital I/O
- Container-in-place input
- Fast and slow fill, complete, zero, discharge
- Print output



Suggested Hardware (Recipe and Filling/Dosing):

- PN 171427 Single Channel 1280 Universal
- PN 81076 Epson TM-U220 ticket printer
- PN 23113 Epson TM-U295 ticket printer
- PN 101923 FRP Box with 4-channel rack OPT022 (relays not included)
- PN 19369 FRP Box with Start/Abort/Run



Recipe Program

Formula Batcher is an automated program, with up to eight ingredient setpoints.

- Single scale and digital I/O option cards
- Auto tare, begin/end and store
- Formula, ingredient and transaction storage
- Transmit fill and accumulation through serial ports
- Built-in safety interlocks
- Batch ticket and total report
- Start/E-stop, fast and slow fill, complete and discharge outputs

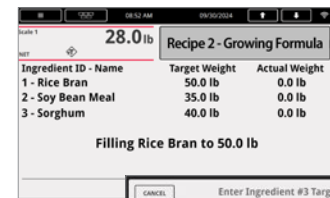

INDICATORS / CONTROLLERS

920i® Series

User Programs



Standard Features

- Pre-programmed software to carry out specific weighing functions
- Utilize Rice Lake's iRite™ programming language
- For use with all Rice Lake 920i models (hardware requirements may apply)
- Available pre-installed with purchase of new equipment, or via iRev™ for installation on existing 920i models
- Fully customizable

INDICATORS / CONTROLLERS

Part Number/Price

Part #	Description	Price
153146	Short axle weighing program	\$595.00
SZ99999	Truck in/out with report	\$73.00
77297	Truck in/out with products/customers/trucks and reports	\$495.00
156886	Grain program with shrink calculation	\$395.00
156959	Dual kiosk truck in/out single scale	\$1,050.00

Short Axle Weighing Program

PN 153146:

920i custom program will interface to a short axle scale and direct each axle across the scale using traffic lights.

Suggested Hardware:

- PN 67527 920 single channel A/D
- PN 23113 Epson TM-U295 ticket printer
- PN 101923 FRP box with 4 channel relay rack, for traffic light control
- PN 23146 Traffic light kit
- PN 15971 AC output relays for above (2 needed)
- PN 103181 LaserLight remote display (optional)
- PN 167093 LaserLight2™ remote display (optional)

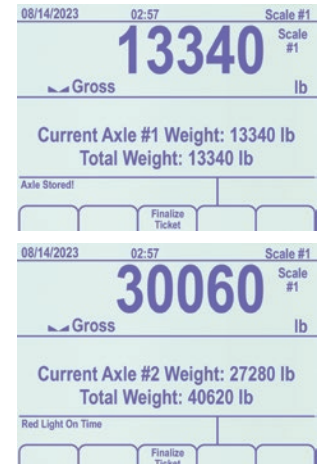

Grain Program with Shrink Calculator

PN 156886:

This custom application for the 920i supports weighing trucks of grain. Up to 200 grain types, associated divisors and accumulator can be stored. Up to 500 accounts and 1,000 trucks can be stored.

Suggested Hardware:

- PN 67527 920i single channel A/D
- PN 67600 1M memory card
- PN 23113 Epson TM-U295 ticket printer
- PN 93359 PS/2 keyboard

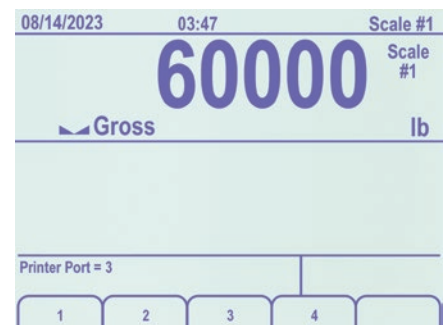

Truck In/Out with Products/ Customers/Trucks and Reports



PN 77297:

This program supports truck in/out weighing program for manual truck transactions using Rice Lake Weighing Systems' 920i digital weight indicator. Stored IDs allow you to keep a database of truck IDs, customer, product, project information and weigh-in weights in the indicator's memory. Parameters are accessed by simply scrolling through the Supervisor main menu using the down arrow on the 920i. The 920i can automatically store up to 100 truck IDs and tare weights, 950 customers, 1,000 products and 1,000 projects.

Suggested Hardware:

- PN 67527 920i single channel A/D
- PN 67600 1MB memory card
- PN 23113 Epson TM-U295 ticket printer
- PN 93359 PS/2 keyboard

INDICATORS / CONTROLLERS

Dual Kiosk Truck In/Out Single Scale



PN 156959:

System consists of a bidirectional single platform truck scale, inbound truck kiosk and outbound truck kiosk. Inbound (if two outbound kiosks are used) and outbound tickets with transaction storage of each weighing.

Suggested Hardware:

- (2) PN 119687 Inbound/Outbound kiosk
- PN 119689 A/D kiosk option

Truck In/Out with Report



PN SZ99999:

920i program allows trucks to weigh in and out (saves inbound weight after weighing out and has value swapping) and stores the transaction after each weigh out with truck ID, gross, tare and net. Transactions may be printed or cleared at any time through the Setup menu. An HID scanner is available as a peripheral piece of hardware.

Suggested Hardware:

- PN 119687 Outbound kiosk
- PN 119689 A/D kiosk option
- PN 119743 HID kiosk option

920i® FlexWeigh Systems

Fillers/Batchers

INDICATORS /
CONTROLLERS



Manufacturer-Approved
DIRECT REPLACEMENT FOR FLEXWEIGH'S DWM-IV

Approvals



Standard Features

- Wall mount stainless steel enclosure
- Front panel switches E-Stop, Reset/Resume, Start
- Softkeys for presets, CN#, ID#, formula#, totals
- Accumulating subtotal and total registers
- Transmitted audit trail
- Digital I/O board
- Relay rack and SSR relay outputs

Standard Switches	101	102	103	104	201	202
E-Stop mushroom	X	X	X	X	X	X
Reset/resume	X	X	X	X	X	X
Start	X	X	X	X	X	X
Discharge	-	X	-	-	-	X

Standard Outputs	101	102	103	104	201	202
Fast fill**	X	X	X	X	X	X
Slow fill***	X	X	X	X	X	X
Fill complete*	OPT	OPT	X	X	OPT	OPT
Zero tolerance	OPT	OPT	-	-	OPT	OPT
Discharge	-	X	-	-	-	X
Refill	-	-	X	-	-	-
Refill complete	-	-	OPT	-	-	-
Slow cycle	-	-	OPT	X	-	-

* Dispense for 103 and 104

** Fast Fill Ingredient 1 201/202

*** Fast Fill Ingredient 2 201/202

920i Flexweigh systems are designed for 120VAC line voltage. If the application requires 220VAC or DC control voltage, please consult with sales before placing an order.

101 Basic Filler

Place an empty container on the scale. Automatically fill the container to a preset weight. Remove the container from the scale. Replace it on the scale with an empty container and repeat the process.

102 Automatic Fill, Automatic Discharge

Place an empty container under the scale. Automatically fill the scale to a preset weight. Discharge the scale into the container. Remove the container from under the scale. Replace it under the scale with another empty container and repeat the process.

103 Loss-In-Weight Filler

Dispense preset net weight quantities from the scale until either low level or less-than-preset gross weight is achieved. Then refill to high level.

104 Loss-In-Weight Filler

Product supply containers are placed on the scale. Net weight quantities are dispensed from the containers until empty. When containers empty in the middle of a dispense cycle, the cycle is paused and allowed to resume where it left off when the empty containers are replaced on the scale with filled ones.

201 Four Ingredient Dual Speed or Eight Ingredient Single Speed Batcher

Place empty container on scale, automatically fill multiple ingredients in a sequential order to preset formula weights. Remove the container, replace with empty and repeat.

202 Four Ingredient Dual Speed or Eight Ingredient Single Speed With Discharge

Fill tank or hopper with multiple ingredients in a sequential order then empty into a vessel below.

Part Number/Price

Part #	Description	Est. Weight	Price
120320	920i FlexWeigh Systems 101	23 lb	\$5,045.00
199060	920i FlexWeigh Systems 101, includes manual/auto and jog switches	23 lb	\$5,395.00
120321	920i FlexWeigh Systems 102	23 lb	\$5,295.00
199061	920i FlexWeigh Systems 102, includes manual/auto and jog switches	23 lb	\$5,645.00
120322	920i FlexWeigh Systems 103	23 lb	\$5,245.00
120323	920i FlexWeigh Systems 104	23 lb	\$5,045.00
207904	920i FlexWeigh Systems 201	23 lb	\$5,295.00
207905	920i FlexWeigh Systems 202	23 lb	\$5,495.00

Options/Accessories

Part #	Description	Price
120491	920i FlexWeigh Systems 101 manual	\$25.00
120493	920i FlexWeigh Systems 102 manual	\$25.00
124473	920i FlexWeigh Systems 103 manual	\$25.00
120496	920i FlexWeigh Systems 104 manual	\$25.00
152146	920i FlexWeigh Systems 201/202 manual	\$25.00

To have your option factory installed, please specify when placing your order.

Optional Switches (Installed Price: \$150.00)

	Switch Part #	Legend Part #	101	102	103, 104	201	202
Selector 3 position	94296						
Manual/Off/Auto		121035	X	X	X	X	X
Manual Ingredient Select						X	X
Push-button	94276						
Fill		121036	X	X		X	X
Discharge		121037		X			X
Dispense		121038			X		
Refill		121039			X		
Maintained/Off/Spring Return	94299						
Fill On/-/Jog		121040	X	X		X	X
Fill Fast/-/Slow		121041	X	X		X	X
Discharge On/-/Jog		121043		X			X
Discharge Fast/-/Slow		121044		X			X
Dispense On/-/Jog		121046			X		
Dispense Fast/-/Slow		121048			X		
Refill On/-/Jog		121049			X		
Manual Feed		—				X	X

Optional Front Panel Lights (Installed Price: \$150.00)

	Lamp	Legend	101, 102	103	104	201	202
Ready	94289 Green	121051	X			X	X
Fill Complete	94290 Red	121052	X			X	X
Filling	98760 Amber	121053	X				
Filling Fast	98760 Amber	121054	X				
Filling Slow	98760 Amber	121055	X				
Discharging	94292 Blue	121056	X			X	X
Discharging Fast	94292 Blue	121057	X				
Discharging Slow	94292 Blue	121058	X				
Dispensing	98760 Amber	121059		X	X		
Dispensing Fast	98760 Amber	121060		X	X		
Dispensing Slow	98760 Amber	121061		X	X		
Dispensing Complete	94290 Red	121062		X	X		
Refilling	94292 Blue	121063		X			
Refill Complete	94290 Red	121064		X			
Low Supply	94290 Red	121065		X			
Fill Time Alarm	94290 Red	121066		X	X		
Feeding (1-4)	98760 Amber	—				X	X
Slow Cycle	94290 Red	—	X	X	X		

920i® FlexWeigh Systems

Bulkweighers and Flip Flop Fillers

INDICATORS / CONTROLLERS



Approvals



Available with models 107, 108 and 109

Manufacturer-Approved
DIRECT REPLACEMENT FOR FLEXWEIGH'S DWM-IV

Standard Features

- Wall mount stainless steel enclosure
- Application program 107, 108, 109
- Front panel switches E-Stop, Start/Resume, End Cycle, Ship/Recv (only 109)
- Softkeys for presets, ID1 and ID2
- Accumulating weight streaming
- Fill and discharge sequence controls
- Fill and discharge gate monitoring
- Printer online checking
- Weigh and surge hopper overflow monitoring
- Transmitted audit trail
- Digital I/O board
- Relay rack and SSR relay outputs

Options

- Pilot lights for error indication
- Manual override switches

Standard Switches	107	108	109
E-Stop mushroom	X	X	X
Start/Resume	X	X	X
End cycle	X	X	X
Ship/Recv	-	-	X

Standard Inputs	107	108	109
Fill gate closed	X	X	X
Discharge gate closed	X	X	X
Surge hopper not full	X	X	X
Weigh hopper not full	X	X	X
Printer online	X	X	X

Standard Outputs	107	108	109
Slow cycle alarm	OPT	OPT	OPT
Gate alarm	OPT	OPT	OPT
Scale over fill alarm	OPT	OPT	OPT
Lower surge alarm	OPT	OPT	OPT
Printer alarm	OPT	OPT	OPT
Open fill gate	X	X	X
Open discharge gate	X	X	X

Part Number/Price

Part #	Description	Est. Weight	Price
207906	920i FlexWeigh Systems 107	23 lb	\$6,795.00
207907	920i FlexWeigh Systems 108	23 lb	\$6,795.00
207908	920i FlexWeigh Systems 109	23 lb	\$7,145.00
207909	920i FlexWeigh Systems 111	23 lb	\$6,445.00
207910	920i FlexWeigh Systems 112	23 lb	\$6,845.00

107 Shipping Bulkweigher

The 920i FlexWeigh 107 is designed for basic shipping-mode bulkweighing applications. In shipping mode, a scale is loaded and discharged repetitively until the accumulated weight meets the overall target value.

108 Receiving Bulkweigher

The 920i FlexWeigh 108 is designed for basic receiving mode bulkweighing applications. In receiving mode, a scale is loaded and discharged until there is no more product to receive. To end the cycle, the End Cycle button is pressed.

109 Ship/Receive Bulkweigher

The 920i FlexWeigh 109 allows the user to select which mode of operation to use. This is done with a three-position locking key switch.

111 Flip Flop Filler

The 920i FlexWeigh 111 is designed for filling two scales to a target weight in sequential "flip-flop" fashion. As one scale is filled, operators can prep the second scale, e.g., moving a container into place.

112 Flip Flop Filler with Discharge

The 920i FlexWeigh 112 is designed for filling two scales to a target weight in sequential "flip-flop" fashion. As one scale is filled, the second scale is discharged via independent or manual methods.

Options/Accessories

Part #	Description	Price
151848	920i FlexWeigh Systems 107/108/109 manual	\$25.00

To have your option factory installed, please specify when placing your order.

Optional Switches

Installed Price: \$150.00

Type	107	108	109
Manual/Off/Auto	X	X	X
Man Fill On/-/Jog		X	X
Man Disch On/-/Jog		X	X

920i® FlexWeigh Systems

Flow Rate Controllers



Standard Features

- Wall mount stainless steel enclosure
- Application program 105, 106
- Front panel switches E-Stop, Reset/Resume, Start
- Softkeys for presets, CN#, ID#, formula#, totals
- Accumulating subtotal and total registers
- Transmitted audit trail
- Digital I/O board
- Relay rack and SSR relay outputs

105 Basic Flow-Rate Controller

Dispense preset net weight quantities at preset flow rate values.

106 Loss-In-Weight with Flow-Rate Control and Automatic Refill

Dispense preset net weigh quantities at preset flow rate values with automatic refill when gross weight drops below threshold.

Standard Switches/Outputs

Standard Switches	105	106
E-Stop mushroom	X	X
Reset/Resume	X	X
Start	X	X

Outputs	105	106
Fast fill	X	-
Slow fill	X	-
Fill complete*	X	-
Zero tolerance	Opt	-
Discharge	X	X
Refill	-	X
Refill complete	-	Opt
Slow cycle	Opt	Opt

* Dispense for 105 and 106

Approvals



Manufacturer-Approved

DIRECT REPLACEMENT FOR FLEXWEIGH'S DWM-IV

Part Number/Price

Part #	Description	Est. Weight	Price
Consult	920i FlexWeigh Systems 105	23 lb	\$5,545.00
Consult	920i FlexWeigh Systems 106	23 lb	\$5,545.00

Accessories

Part #	Description	Price
Consult	920i FlexWeigh Systems 105 manual	\$73.00
Consult	920i FlexWeigh Systems 106 manual	\$73.00

INDICATORS / CONTROLLERS

920i® FlexWeigh Systems

Hand Batching



Standard Features

- Stainless deep universal mount enclosure
- Softkeys for presets ID#; formulas; accumulating, subtotal and total registers
- Switch for manual confirmation
- 20 ingredient database
- 100 formula database
- Audit trail data output
- Ingredient usage totals

211 Manual Batching System

Prompts the user through manual weight additions based on a pre-entered formula

Approvals



Manufacturer-Approved

DIRECT REPLACEMENT FOR FLEXWEIGH'S DWM-IV

Part Number/Price

Part #	Description	Est. Weight	Price
207927	920i Flexweigh Systems 211	13 lb	\$3,945.00

MSI-8000HD

Digital Weight Indicator/RF Remote Display



INDICATORS /
CONTROLLERS

Approvals



Standard Features

- Compatible with all ScaleCore™ based products
- LCD display
- Time and date
- Membrane keypad for remote-control functionality
- User-definable function keys for added versatility
- Swivel tilt stand

Dimensions

MSI-8000HD	
A	5.09 in (129 mm)
B	8.98 in (228 mm)
C	1.35 in (34 mm)
D	1.63 in (41 mm)

With Tilt Stand	
A	11.06 in (281 mm)
B	9.13 in (232 mm)
C	9.50 in (241 mm)
D	8.02 in (204 mm)
E	6.16 in (156 mm)
F	3.25 in (83 mm)

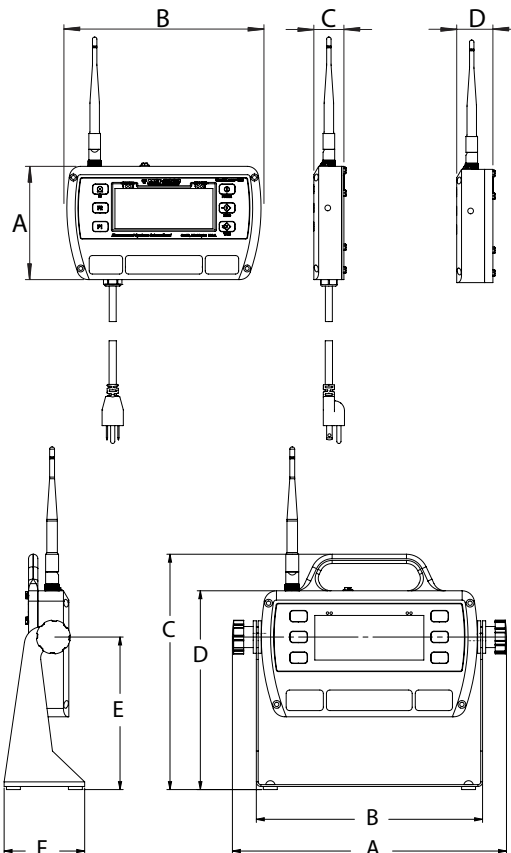

Options

(Contact MSI for application consultation)

- 18 to 72 VDC power
- Up to 8 configurable relay outputs
- Wi-Fi communications
- Wi-Fi indicators
- 802.15.4 Serial RF
- FHSS
- Wired Ethernet

Specifications

Power:

90 to 267 VAC, 9 to 36 VDC, 18 to 72 VDC,
120 to 300 VDC
Optional battery power module available

Excitation Voltage:

4.8 V current limited and over-voltage protected

RF Remote Channels:

Up to four remote sensors, monitored individually,
in pairs or sum all (non-A/D version only)

Service Counters:

A/D version only

A/D Inputs:

Two independent or summing load cell inputs

Filtering:

Off, Low, Hi-1, Hi-2

RF Radio Link:

2.4 GHz 802.15.4

Compatible with all ScaleCore™ based
products, including:

MSI-7300 Dyna-Link 2,

MSI-3460 Challenger 3,

MSI-4260 Port-A-Weigh, MSI-7000 and MSI-7001

RF Effective Range:

Typically 100 to 300 ft. line of sight;
for longer range consult factory

Communication Ports:

Dual RS-232 communication ports

Annunciators:

Stable, COZ, Peak, kg, kN, lb, M, Ton, Setpoint,

Function LEDs

Channels: 1, 2, 3, 4, TTL

Display:

Six-digit 1.0 in (26.4 mm) LCD

Units Displayed:

Pounds, kilograms, tons, metric tons, kilonewtons

Keys/Buttons:

On/Off, zero (100%), tare, print, and two user-
defined keys for the following functions: peak hold,
high resolution, total, view total, net/gross,
units switching

Rating/Material:

Enclosure: NEMA Type 4, IP66 milled anodized
aluminum with O-ring gaskets

Temperature:

Certified: 14 °F to 104 °F (-10 °C to 40 °C)

Operating: -4 °F to 140 °F (-20 °C to 60 °C)

Warranty:

One-year limited

Approvals:

NTEP 15-110

MSI-8000HD

Digital Weight Indicator/RF Remote Display

Part Number/Price

Part #	Description	Est. Weight	Price
Indicator			
158427	Indicator, dual channel, 85 to 265 VAC	5 lb (2.5 kg)	\$2,025.00
158428	Indicator, dual channel, internal battery	5 lb (2.5 kg)	\$2,150.00
160478	Indicator, dual channel, 7 to 36 VDC	5 lb (2.5 kg)	\$1,825.00
159380	Indicator, dual channel, 9 to 36 VDC	5 lb (2.5 kg)	\$1,850.00
158425	Indicator, RF, dual channel, 85 to 265 VAC	5 lb (2.5 kg)	\$2,050.00
158426	Indicator, RF, dual channel, internal battery	5 lb (2.5 kg)	\$2,175.00
160477	Indicator, RF, dual channel, 7 to 36 VDC	5 lb (2.5 kg)	\$2,050.00
159378	Indicator, RF, dual channel, 9 to 36 VDC	5 lb (2.5 kg)	\$2,075.00
Remote Display			
153591	Remote display, RF, 85 to 265 VAC	5 lb (2.5 kg)	\$1,675.00
154853	Remote display, RF, internal battery	5 lb (2.5 kg)	\$1,825.00
160476	Remote display, RF, 7 to 36 VDC	5 lb (2.5 kg)	\$1,625.00
159376	Remote display, RF, 9 to 36 VDC	5 lb (2.5 kg)	\$1,650.00

Options/Accessories

Part #	Description	Price
155173	MSI-8000HD spare tilt stand option kit	\$94.00
155193	MSI-8000HD Ethernet TCP/IP option kit wired	\$475.00
162178	Antenna extension kit, 6 ft	\$535.00
148624	MSI-8000HD serial RS-232 cable	\$150.00
158779	MSI-8000HD two each coil relay option kit, 250 VAC/30 VDC 5 A or 100 VDC 0.4 A	\$410.00
158780	MSI-8000HD two each solid state relay option kit, 60 V pk 2.7 A	\$410.00
158781	MSI-8000HD two each solid state relay option kit, 200 V pk 0.9 A	\$420.00
149549	Universal 115/230 VAC 50/60 Hz (NA plug standard) battery charger for MSI-8000HD battery powered device	\$180.00
149550	Universal 115/230 VAC 50/60 Hz (international plugs) battery charger for MSI-8000HD battery powered device	\$180.00
171203	Audible alarm kit	\$390.00
176963	Serial print cable (for GoDex printer)	\$175.00
Relays		
172490	Expanded relay kit, four-channel, 12 A 5 V, latching relays	Consult
172492	Expanded relay kit, four-channel, 12 A 5 V, momentary relays	Consult
Consult	Expanded relay kit, four-channel, 0.9 A 200 V pk, AC/DC solid state relays	Consult
172495	Expanded relay kit, eight-channel, 12 A 5 V, momentary relays	Consult
172500	Expanded relays option kit, four-channel, 3 A, 60 V pk solid state Form C relays	Consult
172501	Expanded relays option kit, eight-channel, 3 A 60 V pk, solid state Form C relays	Consult
172502	Expanded relays option kit, eight-channel, 0.9 A 200 V pk, solid state Form C relays	Consult
171676	Expanded relays option kit, eight-channel, 12 A 5 V, latching relays	Consult

INDICATORS / CONTROLLERS

MSI-8004HD

Digital Weight Indicator/RF Remote Display

INDICATORS /
CONTROLLERS



Approvals



Measurement
Canada
Approved

Standard Features

- Multicolor LED display
- Backlit membrane keypad for user functioning and controls
- Tilt bracket included
- Color changing display (via setpoints)

Options

(Contact MSI for application consultation)

- Expanded relay outputs
- Battery pack for mobile operation
- Second radio module for additional network connectivity
- Remote display 8 to 32 VDC
- Remote display 5 VDC
- Remote display 9 to 36 VDC
- Indicator 8 to 32 VDC
- Wired Ethernet
- Single and dual channel analog output
- Additional antenna kits
- Extended relay option kits

Part Number/Price

Part #	Description	Price
Indicator		
221177	AC Power (85 to 264 VAC), Multi-color display, RF	\$2,075.00
221183	AC Power (85 to 264 VAC), Multi-color display, RF, Instant power-on	\$2,050.00
221179	DC Power (9 to 36 VDC), Multi-color display, RF	\$2,075.00
221181	DC Power (5 VDC), Multi-color display, RF	\$2,225.00
Remote Display		
221176	AC Power (85 to 264 VAC), Multi-color display, RF	\$2,075.00
221180	External battery (Li-ion 5V/3A), multi-color display, RF	\$2,025.00

Specifications

Power:

90 to 267 VAC, 9 to 36 VDC, 18 to 72 VDC,
120 to 300 VDC

Excitation Voltage:

4.8 V current limited and over-voltage protected

Functions:

Peak hold, high resolution, total, view total
net/gross, units switching

Units:

Pounds and kilograms

Channels:

1, 2, 3, 4, TTL

RF Remote Channels:

Up to 4 remote sensors, monitored individually,
in pairs or sum all (non-A/D version only)
(when used with TranSend™)

Service Counters:

A/D version only

A/D Inputs:

Two independent or summing load cell inputs

Relays:

Two 5 V coil, 250 VAC, 5 A relays

Filtering:

Off, Low, Hi-1, Hi-2

RF Radio Link:

2.4 GHz 802.15.4, optional second channel
for Serial RF, 802.11 Wi-Fi

RF Effective Range:

Typically 100 to 300 ft, line of sight; for longer
range consult factory

Communication Ports

Two RS-232 hard wired communication ports

Annunciators:

Stable, COZ, BT, RF, TTL, NET, kg, lb

Display:

Six-digit, 1.5 in (38 mm) LED display with red/green/
orange coloring

Keys/Buttons:

On/Off, Zero, Tare, Print and two user-defined keys

Temperature:

Certified: 23 °F to 104 °F (-5 °C to 40 °C)
Operating: -40 °F to 140 °F (-40 °C to 60 °C)

Rating/Material:

NEMA Type 4, IP66 milled anodized aluminum

Warranty:

One-year limited

Approvals:

NTEP 17-036
Measurement Canada AM-6068

MSI-8004HD

Digital Weight Indicator/RF Remote Display

Options/Accessories

Part #	Description	Price
162178	Antenna extension kit, 6 ft	\$535.00
197013	Antenna extension kit, 20 ft	\$575.00
199105	Audible alarm not compatible with battery versions	Consult
22436	Cable assembly, DB9F to bare wires, 6 in, Gen 1	\$77.00
148624	Cable assembly, RS232 DB9, Gen 2	\$150.00
183437	Battery, 5V Li-ion battery with USB power ports. Output 5 V/3.0 A per port (6.0 A max) rate, 2 A per port (4 A if both ports are used).	\$245.00
187425	8004 option kit, Wi-Fi with TNC connector	\$210.00
187424	8004 option kit, 2nd Xbee® with TNC connector	\$220.00
223594	Option Kit, Dual Analog Output, 8004HD	\$625.00
224817	Ethernet (forward module only)	\$250.00

Dimensions

MSI-8004HD			
With Tilt Stand			
A	11.10 in (282 mm)	E	9.13 in (232 mm)
B	8.76 in (223 mm)	F	6.16 in (156 mm)
C	8.02 in (204 mm)	G	3.25 in (83 mm)
D	5.09 in (129 mm)	H	1.66 in (42 mm)

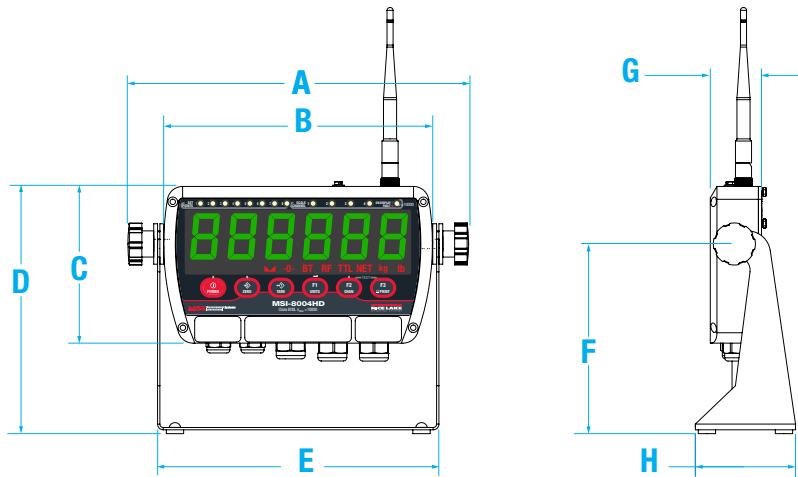

INDICATORS /
CONTROLLERS

SCT-1100

Signal Conditioning Transmitter

INDICATORS /
CONTROLLERS



SCT1100-AN with Analog Output



SCT-1100-AN in Plastic Enclosure

Approvals



Standard Features

- Up to four independent scales or four load cell inputs
- Quick menu for real and theoretical calibration
- Red LED display
- DIN rail mountable
- Configurable calibration and setup parameters from keyboard
- Calibration using linearization points
- Reading of the net, gross and tare weights, clearing, semi-automatic and preset tare, scale switch, setting of outputs application thresholds
- Diagnostic information via serial port, message display, printing, setting of APW in counting mode, digital input for key press
- Modbus RTU or ASCII protocol
- Easy configuration with Rice Lake Tools software

Part Number/Price

Part #	Description	Est. Weight	Price
202101	Indicator, SCT-1100-AN four load cell input with Analog Output	1 lb	\$600.00
197011	Indicator, SCT-1100-AN four load cell input with Analog Output in plastic enclosure	1 lb	\$750.00

NOTE: PN 182588 is superseded by 202101

Options/Accessories

Part #	Description	Est. Weight	Price
188483	SCT-1000 converter RS-232/485 to Ethernet TCP/IP and Modbus TCP. Does not have an A/D	1 lb	\$400.00
88792	12 VDC 1.2 A DIN rail mount power supply	1 lb	\$140.00
119244	24 VDC 1.3 A DIN rail mount power supply	1 lb	\$160.00



SCT-1000
Serial to Ethernet converter

Specifications

- Power:**
12/24 VDC
- Power Consumption:**
70 mA min to 100 mA max
- Excitation Voltage:**
5VDC, 120 mA, 8 × 350 ohm load cells
- Analog Signal Input Range:**
± 39 mV
- Analog Signal Sensitivity:**
0.3 μ V/graduation minimum
- A/D Sample Rate:**
Four channel A/D 24-bit sigma-delta conversion, up to 200 conv./sec. auto select
- Resolution:**
Internal: 1,500,000 counts
Display: 800,000
- Digital I/O:**
Two inputs: 12/24 VDC
Two outputs: 150 mA 48 VAC/150 mA 60 VDC
- Serial Ports:**
Modbus RTU or ASCII selectable/bidirectional (both ports)
(1) RS-485 for connection to a PC or weight repeater
(1) RS-232 for connection to a PC or printer
- Analog Output (if equipped):**
Opto isolated, 16-bit
0 to 20mA, 4 to 20mA (Maximum 350 ohm)
0 to 5VDC, 0 to 10VDC (Minimum 10,000 ohm)
- Annunciators:**
Net, center of zero, stability
- Display:**
Six-digit (10 mm), red LED
- Keys/Buttons:**
Five key, membrane panel, tactile feel Zero (Down), Tare (Up), Mode (Right), Print (Enter), C (On/Off)
- Dimensions:**
(L × W × H)
4.17 × 3.54 × 2.28 in
(106 × 90 × 58 mm)
- Temperature:**
5 °F to 104 °F (-15 °C to 40 °C)
- Humidity:**
85% non-condensing
- Rating/Material:**
Enclosure: NEMA Type 4, plastic
Clear cover: six PG9 cord grips
- Warranty:**
One-year limited
- Approvals:**
NTEP 20-046
Measurement Canada AM-6165C
OIML R76/2006-A-GB1-19.17
UKCA Marked
cULus Listed



SCT2200 pictured with optional EtherNet/IP module

Approvals



Standard Features

- HUB mode connects up to 16 transmitters to one fieldbus
- Two RS-485 port for "daisy-chain" network connection
- Quick menu for real and theoretical calibration
- Remote access through web browser for weight monitoring and calibration over EtherNet/IP™, PROFINET and Modbus TCP network
- Red LED display
- DIN rail mountable
- Calibration using linearization points
- Reading of the net, gross and tare weights, clearing, semi-automatic and preset tare setting of outputs application thresholds
- Diagnostic information via serial port, message display, printing, simulation of key pressure, Modbus RTU or ASCII protocol
- Printer management on second serial port available
- Multi-range function allows for subdividing the scale capacity in two, each up to 3,000 divisions
- Easy configuration with Rice Lake Tools software

Part Number/Price

Part #	Description	Est. Weight	Price
Transmitters			
202103 *	Indicator, SCT-2200 for scale input to be used with fieldbus module	1 lb	\$400.00
202104 *	Indicator, SCT-2200-AN with analog output to be used with fieldbus module	1 lb	\$525.00
Fieldbus			
182592	Fieldbus, SCT-2200, PROFINET module	1 lb	\$700.00
194343	Fieldbus, SCT-2200, Ethernet TCP/IP and Wi-Fi	1 lb	\$620.00
182593	Fieldbus, SCT-2200, PROFIBUS® module	1 lb	\$425.00
182591	Fieldbus, SCT-2200, EtherNet/IP™ module	1 lb	\$700.00
182596	Fieldbus, SCT-2200, DeviceNet® module	1 lb	\$625.00
182598	Fieldbus, SCT-2200, EtherCAT module	1 lb	\$620.00
182597	Fieldbus, SCT-2200, CANopen module	1 lb	\$620.00
196694	Fieldbus, SCT-2200, Modbus TCP module	1 lb	\$675.00
182599	Cable with RJ45 plugs, 6 in length	1 lb	\$15.00
212772 **	Fieldbus, SCT-2200, PROFIBUS module	1 lb	\$425.00

NOTE: PN 182587 is superseded by 202103 and PN 182589 is superseded by 202104.

*How to Order the SCT-2200 for use with fieldbus module

Order 1 RJ45 cable for every Scale module connected to a Fieldbus module.

** Compatible with 682 indicator

Options/Accessories

Part #	Description	Est. Weight	Price
88792	12 VDC 1.2 A DIN rail mount power supply	1 lb	\$140.00
119244	24 VDC 1.3 A DIN rail mount power supply	1 lb	\$160.00

Specifications

- Power:**
12/24 VDC
- Power Consumption:**
70 mA min to 100 mA max
- Excitation Voltage:**
5 VDC, 120 mA, 8 × 350 ohm load cells
- Analog Signal Input Range:**
± 39 mV
- Analog Signal Sensitivity:**
0.3 µV/graduation minimum
- A/D Sample Rate:**
One channel A/D 24-bit sigma-delta conversion, up to 200 conv/sec. auto select
- Resolution:**
Internal: 1,500,000 counts
Display: 800,000
- Digital I/O:**
Two inputs: 12/24 VDC
Two outputs: 150 mA 48 VAC/150 mA 60 VDC
- Communication Ports:**
(1) RS-485, (1) RS-232
Analog output (if equipped):
Opt isolated, 16-bit
0-20 mA, 4-20 mA (Maximum 350 ohm)
0-5 VDC, 0-10 VDC (Minimum 10,000 ohm)
- Annunciators:**
Net, center of zero, stability
- Display:**
Six-digit 0.31 in (8 mm), red LED
- Keys/Buttons:**
Five key, tactile feel
Zero (Down), Tare (Up), Mode (Right), Print (Enter), C (On/Off)
- Dimensions:**
(L × H × D)
4.72 × 4.52 × 0.98 in
(120 × 115 × 25 mm)
- Temperature:**
Certified: 14 °F to 104 °F (-10 °C to 40 °C)
Operating: 14 °F to 122 °F (-10 °C to 50 °C)
- Humidity:**
85% non-condensing
- Rating/Material:**
NEMA Type 1 plastic pluggable connectors
- Weight:**
1 lb (0.5 kg)
- Warranty:**
One-year limited
- Approvals:**
NTEP 20-046
Measurement Canada AM-6165C
OIML R76/2006-A-GB1-19.17
UKCA Marked
cULus Listed

SCT-3300

Signal Conditioning Transmitter

INDICATORS /
CONTROLLERS

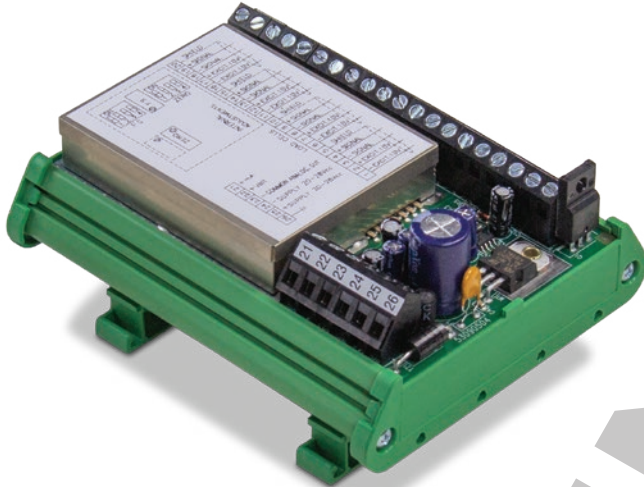

Approvals

UK
CA

Part Number/Price

Part #	Description	Est. Weight	Price
Transmitters			
188725	Indicator, SCT-3300 four load cell input with Analog Output	1 lb	\$400.00

Options/Accessories

Part #	Description	Est. Weight	Price
88792	12 VDC 1.2 A DIN rail mount power supply	1 lb	\$140.00
119244	24 VDC 1.3 A DIN rail mount power supply	1 lb	\$160.00

Standard Features

- Powers up to six (350 ohm) load cells in parallel
- Analog amplifier and transmitter
- Analog output: 0-20 mA, 4-20 mA, 0-10 V
- Mounting on Omega/DIN rail for back panel or junction box

Specifications

Power:

Input: 20 to 28 VDC

Power Consumption:

8 W

Excitation Voltage:

10 VDC, 170 mA, 6 × 350 ohm load cells

Analog Signal Input Range:

3.5 to 24 mV

Analog Signal Sensitivity:

0.3 μ V/graduation minimum
1.0 μ V/graduation recommended

A/D Sample Rate:

300 Hz

System linearity:

\pm 0.01% full scale

Analog Output (if equipped):

Opto isolated
0-20 mA, 4-20 mA (max 300 ohm)
0-10 VDC (min 10,000 ohm)

Dimensions:

(L × W × H)
4.56 × 3.72 × 2.4 in
(114 × 93 × 60 mm)

Temperature:

Operating: 14 °F to 122 °F (-10 °C to 50 °C)

Humidity:

85% non-condensing

Rating/Material:

DIN rail mount: NEMA Type 1

Weight:

0.5 lb (0.2 kg)

Warranty:

One-year limited

Approvals:

UKCA Marked



Standard Features

- Integrated web server allows complete diagnostics, calibration and remote configuration
- Real-time warning of any faults or disconnections of the load cell
- Configuration and calibration through Rice Lake Tools, XSpeed software or display navigation
- Power supply circuit with protections against overloads, polarity reversal and short circuits, specific for industrial environments
- Micro-USB communication and configuration port accessible from display for quick programming, diagnostics and data backup
- All scale data and adjustments are available through integrated fieldbus with up to 120 updates per second
- Removable terminal blocks to simplify wiring in the electrical panel
- Modbus RTU protocol integrated, up to 110 updates per second

Part Number/Price

Part #	Description	Est. Weight	Price
229189	SCT1PX-AN		\$500.00
229190	SCT1PX-PRONET		\$750.00
229191	SCT1PX-ETHIP		\$750.00
229192	SCT1PX-MODTCP		\$750.00

Options/Accessories

Part #	Description	Est. Weight	Price
88792	12 VDC 1.2 A DIN rail mount power supply	1 lb	\$140.00
119244	24 VDC 1.3 A DIN rail mount power supply	1 lb	\$160.00
Consult	Alibi Memory for type-approved communication to PC/PLC (fiscal memory, max 120,000 weighs) built-in real time clock to print the date/time with PCB, screw terminal, plastic box		Consult
Consult	Real time clock for printing/displaying of date and time		Consult

Specifications

Power:

12 to 24 VDC

Power Consumption:

5 W

Excitation Voltage:

5 VDC, 230 mA

up to 16 × 350 ohm load cells

Analog Signal Input Range:

±39 mV

Analog Signal Sensitivity:

0.3 µV/graduation minimum

A/D Sample Rate:

24-bit A/D

Single channel up to 4,800 Hz

Resolution:

Internal: 4,000,000 counts

Display: up to 800,000

Up to 8 linearization points

Digital I/O:

Two inputs: 12/24 VDC

Two outputs*: 500 mA, up to 48 VAC or 60 VDC

*(up to six with option for analog version only)

Serial Ports:

One micro-USB port (device) for PC configuration

One RS-485

EtherNet/IP™ or PROFINET IO or Modbus TCP

(Fieldbus version)

Analog Output (if equipped):

Opt. isolated, 16-bit

0 to 20 mA, 4 to 20 mA (maximum 350 ohm)

0 to 5 VDC, 0 to 10 VDC (minimum 10,000 ohm)

Annunciators:

Nine LEDs

Display:

Six-digit 0.56 in (14.2 mm), red LED

Keys/Buttons:

Five tactile keys

Zeroing, Tare, function mode, manual data printing/

sending, On/Stand-by

Dimensions:

(L × W × H)

3.93 × 2.08 × 5.35 in

(100 × 53 × 136 mm)

Temperature:

Certified: 14 °F to 104 °F (-10 °C to 40 °C)

Operating: -4 °F to 140 °F (-20 °C to 60 °C)

Humidity:

85% RH, non-condensing

Rating/Material:

Aluminum IP65

Warranty:

One-year limited

Approvals:

CE-M EN 45501

UL

SCT-1SX

Transmitter with Integrated Fieldbus and Web Server



INDICATORS /
CONTROLLERS

Standard Features

- Load cell status diagnostics
- USB port for quick programming
- Integrated fieldbus and web server for configuration, diagnostics and data backup
- Process up to 4800 weight readings per second. The high speed allows an extremely accurate weight filtering even with weighing being performed in milliseconds.
- Up to 120 updates per second on Fieldbus
- New power supply circuit of the load cells (up to 16) for a better weighing stability
- Power supply circuit with protections against overloads, polarity reversal and short circuits, specific for industrial environments
- Micro-USB communication port for configuration, diagnostics and data backup is available on all versions
- Modbus RTU protocol integrated on all versions, up to 110 updates per second
- Real-time warning of any faults or disconnections of the load cell
- The integrated web server allows full diagnostics, calibration and remote configuration of the weight transmitter from an Ethernet network
- Calibration via theoretical (m/V), with sample weights, web server or xSpeed software tool
- Easy configuration with Rice Lake Tools software

Optional xSpeed Software

- Customization of the weighing filter, to maximize the speed and accuracy in static and dynamic applications
- Graphical weighing analysis for the identification of mechanical disturbances and vibrations. Oscilloscope function for system diagnostics and filter optimization.

Part Number/Price

Part #	Description	Est. Weight	Price
216820	SCT-1SX-AN weight transmitter and analog output for DIN rail mount with digital I/O 2 IN and 4 OUT		\$900.00
229550	SCT-1SX-ETHIP weight transmitter and EtherNet/IP™ port for DIN rail mount with digital I/O 2 IN and 4 OUT, integrated web server		\$1,295.00
216821	SCT-1SX-PRONET weight transmitter and PROFINET port for DIN rail mount with digital I/O 2 IN and 4 OUT, integrated web server		\$1,295.00
216823	SCT-1SX-MODTCP weight transmitter and Modbus TCP port for DIN rail mount with digital I/O 2 IN and 4 OUT, integrated web server		\$1,295.00

Options/Accessories

Part #	Description	Est. Weight	Price
88792	12 VDC 1.2 A DIN rail mount power supply	1 lb	\$140.00
119244	24 VDC 1.3 A DIN rail mount power supply	1 lb	\$160.00
Consult	Alibi Memory for type-approved communication to PC/PLC (fiscal memory, max 120,000 weighs) built-in real time clock to print the date/time with PCB, screw terminal, plastic box		Consult
Consult	Real time clock for printing/displaying of date and time		Consult

Specifications

- Power:**
12 to 24 VDC, 5 W
- Power Consumption:**
70 mA min to 100 mA max
- Excitation Voltage:**
5V, 250 mA, 16 × 350 ohm load cells
- Analog Signal Input Range:**
±39 mV
- Analog Signal Sensitivity:**
High resolution 0.01 µV/d
Legal for trade 0.3 µV/e
- A/D Sample Rate:**
Up to 4800 Hz
- Resolution:**
Internal: 1,500,000 counts
Display: 800,000
Legal for Trade divisions
Up to 10,000e or multi-field 2 × 3,000e
- Digital I/O:**
Two inputs, configurable: 12 to 24 VDC
Four outputs, configurable: 150 mA 48 VAC/150 mA 60 VDC
- Communication Ports:**
One RS-485, one RS-232,
one micro-USB port (device)
Serial port update rate: up to 1600 Hz
Fieldbus update rate: up to 120 Hz
- Analog Output (if equipped):**
OPTO isolated, 16-bit
0 to 20 mA, 4 to 20 mA (maximum 350 ohm)
0 to 5 VDC, 0 to 10 VDC (minimum 10,000 ohm)
- Annunciators:**
Net, center of zero, stability
- Display:**
Six-digit (8 mm), red LED
- Keys/Buttons:**
Five key, membrane panel
Zero (down), Tare (up), Mode (right), Print (enter),
C (on/off)
- Dimensions:**
(L × W × H)
4.72 x 0.9 x 4.0 in
(120 x 23 x 112 mm)
- Temperature:**
Certified: 14 °F to 104 °F (-10 °C to 40 °C)
Operating: -4 °F to 140 °F (-20 °C to 60 °C)
- Humidity:**
85% non-condensing
- Rating/Material:**
Enclosure: ABS plastic
- Warranty:**
One-year limited
- Approvals:**
CE-M EN 45501
2014/30/EU EMC
2014/35/EU LVD
2011/65/EU RoHS
OIML R61 - MID
OIML R76



Standard Features

- Manage up to four load cells (one scale) or four scales with load cell feed circuit for greater weighing stability
- Process to 2,600 weight readings per second for single-channel
- Integrated web server allows complete diagnostics, calibration and remote configuration (not available on AN models)
- 14.2 mm display with new configuration menu to simplify calibration and configuration
- All data and adjustments of each scale are available through integrated fieldbus with up to 120 updates per second
- Frontal micro-USB communication port for configuration, diagnostics and data backup
- Removable terminal blocks to simplify wiring in the electrical panel
- RS-485 communication port always available on all versions
- Power supply circuit with protections, specific for industrial environment

Optional xSpeed Software

- Customization of the weighing filter, to maximize the speed and accuracy in static and dynamic applications
- Graphical weighing analysis for the identification of mechanical disturbances and vibrations
- Oscilloscope function for system diagnostics and filter optimization

Part Number/Price

Part #	Description	Est. Weight	Price
216824	SCT-4XAN high speed weight transmitter and analog output for DIN rail mount with digital I/O, 2 IN, 2 OUT, keypad, LED display (does not include web server)		\$950.00
216825	SCT-4X-ETHIP high speed 4 channel weight transmitter and EtherNet/IP™ port for DIN rail mount with digital I/O 2 IN, 2 OUT, 5-key keypad, LED display		\$1,150.00
216826	SCT-4X-MODTCP high speed 4 channel weight transmitter and Modbus TCP port for DIN rail mount with digital I/O 2 IN, 2 OUT, 5-key keypad, LED display		\$1,150.00
216827	SCT-4X-PRONET high speed 4 channel weight transmitter and PROFINET port for DIN rail mount with digital I/O 2 IN, 2 OUT, 5-key keypad, LED display		\$1,150.00

Options/Accessories

Part #	Description	Est. Weight	Price
88792	12 VDC 1.2 A DIN rail mount power supply	1 lb	\$140.00
119244	24 VDC 1.3 A DIN rail mount power supply	1 lb	\$160.00
Consult	Alibi Memory for type-approved communication to PC/PLC (fiscal memory, max 120,000 weighs) built-in real time clock to print the date/time with PCB, screw terminal, plastic box		Consult
Consult	Real time clock for printing/displaying of date and time		Consult

Dimensions

SCT-4X					
A	4.17 in (106 mm)	E	1.77 in (45 mm)	I	0.20 in (5 mm)
B	1.77 in (45 mm)	F	1.30 in (33 mm)	J	0.59 in (15 mm)
C	3.54 in (90 mm)	G	0.54 in (13.7 mm)	K	0.39 in (10 mm)
D	1.38 in (35 mm)	H	2.28 in (58 mm)		

Specifications

Power:

12 to 24 VDC

Power Consumption:

5 W

Excitation Voltage:

5 VDC, 230 mA
up to 16 × 350 ohm cells

Analog Signal Input Range:

± 39 mV

Analog Signal Sensitivity:

0.3 µV/graduation minimum

A/D Sample Rate:

24-bit A/D
Single channel up to 2,600 conv/sec
4 channels up to 100 conv/sec

Resolution:

Internal: 3,000,000 counts
Display: up to 800,000
Up to 8 linearization points

Digital I/O:

Two inputs: 12/24 VDC
Two outputs: 150 mA 48 VAC/ 150 mA 60 VDC

Communication Ports:

1 Micro-USB port (device) for PC configuration
(1) RS-485, (1) RS-232

Analog Output (if equipped):

OPTO isolated, 16-bit
0 to 20 mA, 4 to 20 mA (maximum 350 ohm)
0 to 5 VDC, 0 to 10 VDC (minimum 10,000 ohm)

Annunciators:

Nine LEDs

Display:

Six-digit 0.31 in (8 mm), red LED

Keys/Buttons:

Five tactile keys
Zeroing, Tare, function mode, manual data printing/
sending, on/stand-by

Dimensions:

(L × W × H)
4.17 × 2.20 × 4.64 in
(106 × 56 × 118 mm)

Temperature:

Certified: 14 °F to 104 °F (-10 °C to 40 °C)
Operating: -4 °F to 140 °F (-20 °C to 60 °C)

Humidity:

80% RH, non-condensing

Rating/Material:

NEMA Type 1 plastic pluggable connectors
ABS

Weight:

1 lb (0.5 kg)

Warranty:

One-year limited

Approvals:

CE-M EN 45501

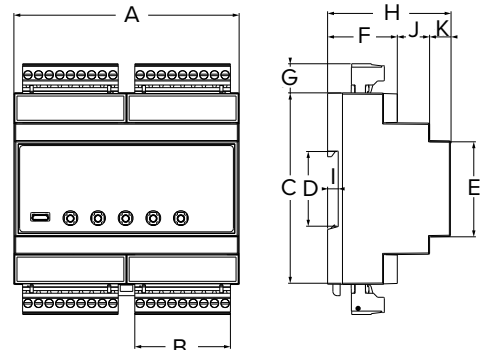

SCT-10

Signal Conditioning Transmitter

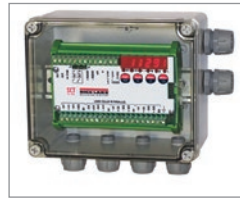
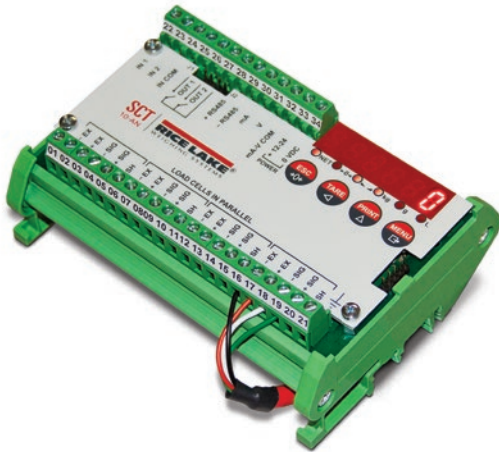

SCT-10 in Plastic Enclosure

INDICATORS /
CONTROLLERS

Approvals



Standard Features

- Converts digital weight to analog output
- Sums four input channels in parallel
- Theoretical calibration, real-weight calibration, linearity calibration
- Push-button or preset tare
- Full-scale analog output with zero setting and PLC correction of analog signal
- Displays weight, configuration, calibration and error conditions
- DIN-rail mounting, suitable for back panel
- Two digital inputs, two digital outputs
- Supports ASCII or Modbus RTU protocols

Part Number/Price

Part #	Description	Est. Weight	Price
129393	SCT-10 converter with Analog Output	1 lb	\$650.00
129394	SCT-10 converter with Analog Output in enclosure	1 lb	\$800.00

Options/Accessories

Part #	Description	Est. Weight	Price
88792	12 VDC 1.2 A DIN rail mount power supply	1 lb	\$140.00
119244	24 VDC 1.3 A DIN rail mount power supply	1 lb	\$160.00
131129	Installation manual	1 lb	\$25.00
199687	DIN rail clip right & left end clamp		\$11.00

Specifications

- Power:**
Input: 12 to 24 VDC
- Power Consumption:**
5 W
- Excitation Voltage:**
5 VDC, 120 mA, 8 × 350 ohm load cells
- Analog Signal Input Range:**
± 19.5 mV
- Analog Signal Sensitivity:**
0.3 μV/graduation minimum
1.0 μV/graduation recommended
- A/D Sample Rate:**
80 Hz
- Resolution:**
Internal: 16,000,000 counts
Display: 999,999
- System Linearity:**
± 0.01% full scale
- Digital I/O:**
2 inputs 5-24 VDC, 2 outputs
24 VDC/60 mA
N.O. or N.C. (solid state)
- Communication Ports**
RS-485 or RS-232 simplex supports
up to 115,200 bps
- Analog Output:**
Opto isolated, 16 bit
0-20 mA, 4-20 mA (max 300 ohm)
0-10 VDC, 0-5 VDC, -10 to 10 VDC,
5 to 5 VDC, (min 10 k ohm)
- Annunciators:**
Net, center of zero, stability,
kg, g, lb
- Display:**
0.3 in (8 mm), six-digit, seven-segment LED
- Keys/Buttons:**
4-key membrane panel, tactile feel
Zero, Tare, Print, Menu, Escape,
Left and Up Navigation, Enter
- Dimensions:**
(L × W × H)
DIN Rail Mount: 4.84 × 3.62 × 1.96 in
(123 × 92 × 50 mm)
Enclosure: 6.69 × 5.51 × 3.74 in
(170 × 140 × 95 mm)
- Temperature & Humidity:**
Operating Temperature: -4 °F to 140 °F
(-20 °C to 60 °C)
Humidity: 85% non-condensing
- Rating/Material:**
DIN rail mount: NEMA Type 1
Enclosure: NEMA Type 4/IP67, plastic
Clear cover: six PG9 cord grips
- Weight:**
1 lb (0.5 kg)
- Warranty:**
One-year limited
- Approvals:**
cULus Recognized

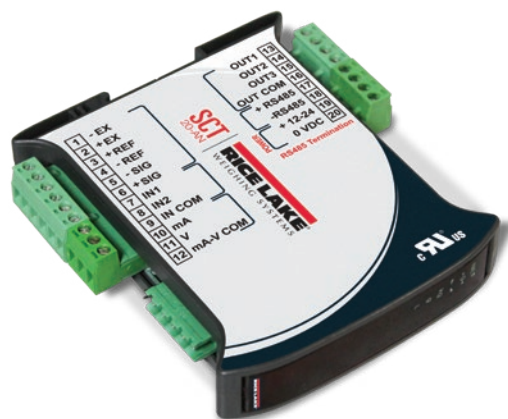

Approvals



Standard Features

- Space saving, vertical shape with DIN-rail mounting
- Displays weight, configuration, calibration and error conditions
- Theoretical calibration, real-weigh calibration, linearity calibration
- Push-button or preset tare
- Converts digital weight to analog output or optional DeviceNet® or PROFIBUS® or EtherNet/IP™ protocol
- Supports ASCII or Modbus RTU protocols
- Full-scale analog output with zero setting and PLC correction of analog signal
- Bit swapping selection for little endian and big-endian format
- Two digital inputs, three digital outputs
- One serial port, RS-232 transmit only, or RS-485 half-duplex connection

Part Number/Price

Part #	Description	Est. Weight	Price
129396	SCT-20 converter with Analog Output	1 lb	\$630.00
129397	SCT-20 converter with DeviceNet®	1 lb	\$725.00
129558	SCT-20 converter with PROFIBUS® DP	1 lb	\$785.00
129398	SCT-20 converter with EtherNet/IP™	1 lb	\$1,050.00
132534	SCT-20 converter with Ethernet TCP/IP	1 lb	\$900.00
156903	SCT-20 converter with Modbus TCP	1 lb	\$1,000.00
131128	Installation manual	1 lb	\$25.00

EtherNet/IP and Modbus output changed to Dual Port in 2019.

Options/Accessories

Part #	Description	Est. Weight	Price
88792	12 VDC 1.2 A DIN rail mount power supply	1 lb	\$140.00
119244	24 VDC 1.3 A DIN rail mount power supply.	1 lb	\$160.00

Specifications

- Power:**
Input: 12 to 24 VDC
- Power Consumption:**
5 W
- Excitation Voltage:**
5 VDC, 120 mA, 8 × 350 ohm load cells
- Analog Signal Input Range:**
± 39 mV
- Analog Signal Sensitivity:**
0.3 µV/graduation minimum
1.0 µV/graduation recommended
- A/D Sample Rate:**
300 Hz
- Resolution:**
Internal: 16,000,000 counts
Display: 999,999
- System linearity:**
± 0.01% full scale
- Digital I/O:**
2 inputs 5 to 24 VDC, 3 outputs 115 VAC/150 mA
N.O. or N.C. (dry contact)
- Communication Ports:**
RS-232 transmit only, or RS-485 half duplex
Supports up to 115,200 bps
- Analog Output:**
Opto isolated, 16 bit
0-20 mA, 4-20 mA (max 300 ohm)
0-10 VDC, 0-5 VDC (min 10 k ohm)
- Display:**
0.3 in (8 mm), six-digit, seven-segment LED
Annunciators: Net, center of zero, stability, kg, g, lb
- Keys/Buttons:**
4-key membrane panel, tactile feel
zero, tare, print, menu, escape, left and up navigation, enter
- Dimensions**
(W × H × D)
4.72 × 4.52 × 0.98 in
(120 × 115 × 25 mm)
- Temperature:**
Operating: -4 °F to 140 °F (-20 °C to 60 °C)
- Humidity:**
85% non-condensing
- Rating/Material:**
Enclosure: NEMA Type 1 plastic
pluggable connectors
- Weight:**
1 lb (0.5 kg)
- Warranty:**
One-year limited
- Approvals:**
NTEP 14-083
cULus Recognized

SCT-30

Signal Conditioning Transmitter

INDICATORS /
CONTROLLERS

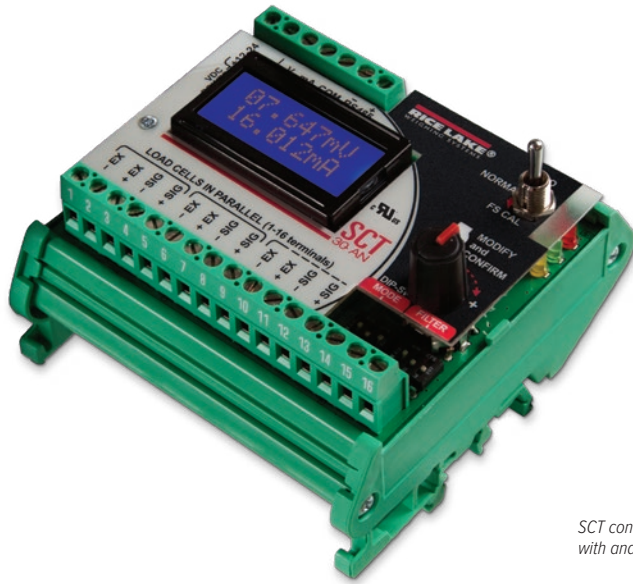

SCT converter
with analog output

Approvals



Part Number/Price

Part #	Description	Est. Weight	Price
156794	SCT-30 converter with Analog Output	1 lb	\$500.00
156834	SCT-30 converter with Analog Output in enclosure	1 lb	\$665.00

Options/Accessories

Part #	Description	Est. Weight	Price
88792	12 VDC 1.2 A DIN rail mount power supply	1 lb	\$140.00
119244	24 VDC 1.3 A DIN rail mount power supply	1 lb	\$160.00
131129	Installation manual	1 lb	\$25.00
199707	DIN rail clip right & left end clamp		\$11.00

Standard Features

- LCD display
- Powers up to eight (350 ohm) load cells in parallel (with a 24-bit A/D converter)
- A/D converter 24-bit 4.8 kHz
- 16-bit analog output: 0-20 mA, 4-20 mA, 0-5 V, 0-10 V, ± 5 V and ± 10 V
- Mounting on Omega/DIN rail for back panel or junction box
- Diagnostic message for load cell disconnect and over-capacity errors

Specifications

Power:

Input: 12 to 24 VDC

Power Consumption:

3 W

Excitation Voltage:

5 VDC, 120 mA, 8 \times 350 ohm load cells

Analog Signal Input Range:

± 39 mV

Analog Signal Sensitivity:

0.3 μ V/graduation minimum

1.0 μ V/graduation recommended

A/D Sample Rate:

300 Hz

Resolution:

Internal: 16,000,000 counts

System Linearity:

$\pm 0.01\%$ full scale

Communication Ports:

RS-485

Analog Output:

Opto isolated, 16 bit

0-20 mA, 4-20 mA (max 300 ohm)

0-10 VDC, 0-5 VDC (min 10 k ohm)

Display:

Eight-digit alphanumeric tow line LCD, 5 mm high

Keys/Buttons:

Control knob and DIP switches

Dimensions:

(L \times W \times H)

3.74 \times 3.54 \times 2.36 in

(95 \times 90 \times 60 mm)

Temperature:

Operating: -4 $^{\circ}$ F to 140 $^{\circ}$ F (-20 $^{\circ}$ C to 60 $^{\circ}$ C)

Humidity:

85% non-condensing

Rating/Material:

DIN rail mount: NEMA Type 1

Weight:

1 lb (0.5 kg)

Warranty:

One-year limited

Approval:

cULus Recognized

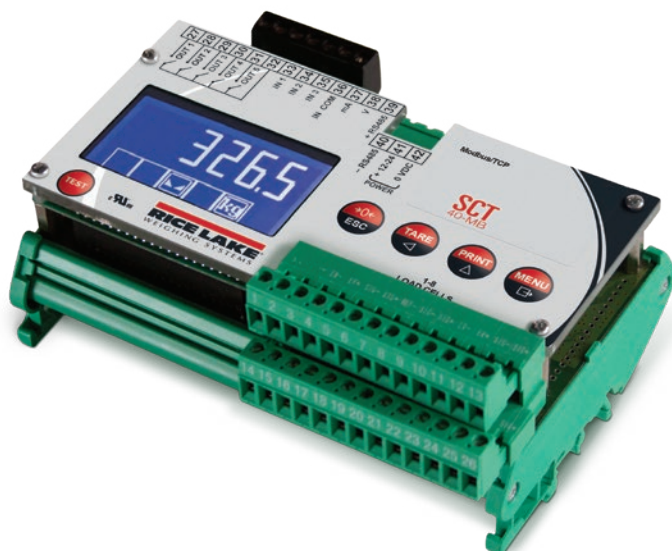

Approvals



Standard Features

- LCD display
- Supports up to eight independent reading channels for load cells
- Displays weight, configuration, calibration and error conditions
- DIN rail mounting
- Theoretical calibration, real-weight calibration and linear calibration
- Push-button or preset tare
- Converts digital weight to analog output or optional DeviceNet®, PROFIBUS®, EtherNet/IP™, PROFINET and Modbus TCP protocols
- Supports ASCII or Modbus RTU protocols
- Bit swapping selection for little endian and endian format
- Three digital inputs, five digital outputs
- One serial port, RS-485 half duplex or RS-232 transmit-only connection

SCT-40AN only

- Full scale analog output with zero setting and PLC correction of analog signal

Part Number/Price

Part #	Description	Est. Weight	Price
170470	SCT-40 with Analog Output	1 lb	\$840.00
170471	SCT-40 with DeviceNet®	1 lb	\$1,045.00
170472	SCT-40 with PROFIBUS®	1 lb	\$1,045.00
170473	SCT-40 with EtherNet/IP™	1 lb	\$1,085.00
170474	SCT-40 with Ethernet TCP/IP	1 lb	\$1,045.00
170475	SCT-40 with Modbus TCP	1 lb	\$1,085.00
170476	SCT-40 with PROFINET IO	1 lb	\$1,085.00

EtherNet/IP and Modbus output changed to Dual Port in 2019

Options/Accessories

Part #	Description	Est. Weight	Price
88792	12 VDC 1.2 A DIN rail mount power supply	1 lb	\$140.00
119244	24 VDC 1.3 A DIN rail mount power supply.	1 lb	\$160.00
131128	Installation manual	1 lb	\$25.00

Specifications

Power:

Input: 12 to 24 VDC

Power Consumption:

5 W

Excitation Voltage:

5 VDC, 240 mA, 16 x 350 ohm load cells

Analog Signal Input Range:

± 39 mV

Analog Signal Sensitivity:

0.3 µV/graduation minimum
1.0 µV/graduation recommended

A/D Sample Rate:

600 Hz

Resolution:

Internal: 16,000,000 counts
Display: 999,999

System Linearity:

± 0.01% full scale

Digital I/O:

3 inputs 5 to 24 VDC, 5 outputs, 115 VAC/150 mA

Communication Ports

RS-232 transmit only, or RS-485 half duplex
Supports up to 115,200 bps

Analog Output (SCT-40AN only):

Opto isolated, 16 bit
0-20 mA, 4-20 mA (max 300 ohm)
0-10 VDC, 0-5 VDC (min 10 k ohm)

Display:

Backlit graphic LCD, transmissive
128 x 64 pixel resolution, 60 x 32 mm visible area

Keys/Buttons:

Five-key tactile keypad
test, zero, tare, print menu, escape, left and up,
navigator, enter

Dimensions:

(L x W x H)
5.82 x 3.62 x 2.36 in
(148 x 92 x 60 mm)

Temperature:

Operating: -4 °F to 140 °F (-20 °C to 60 °C)

Humidity:

85% non-condensing

Rating/Material:

DIN rail mount: NEMA Type 1

Weight:

1 lb (0.5 kg)

Warranty:

One-year limited

Approvals:

cULus Recognized

PROFIBUS® DP Interface

720i™/920i®



Standard Features

- DP intelligent device
- Standard GSD file download from product page
- 128 selectable addresses
- Auto baud rate up to 56 K
- Registered with PROFIBUS Trade Organization
- Onboard diagnostic LEDs

Specifications

- Power:**
5 VDC, 350 mA
- Fieldbus Interface:**
Pluggable screw connector
- Diagnostic LEDs:**
Module status and network status
- Dimensions:**
2.00 × 1.90 × 0.75 in
(51.8 × 48 × 19 mm)
- Temperature:**
Operating:
14 °F to 158 °F (-10 °C to 70 °C)

Part Number/Price

Part #	Description	Est. Weight	Price
68540	PROFIBUS DP interface kit (internal), for 720i/920i indicators	3 lb	\$720.00

Options/Accessories

Part #	Description	Price
69948	Additional operating manual	\$44.00

INDICATORS /
CONTROLLERS

PROFINET IO Interface

920i®

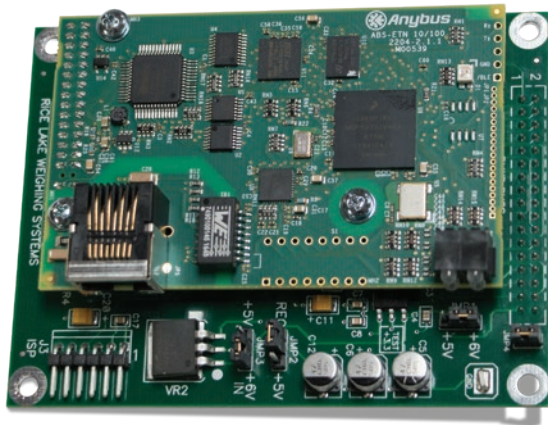

Standard Features

- CE marked and UL conformance
- Onboard diagnostic LEDs
- Control protocols

Specifications

- Power:**
5 VDC, 350 mA (jumper for 6 VDC)
- Fieldbus Interface:**
RJ-45
- Diagnostic LEDs:**
Link status and module status
- Dimensions:**
2.13 × 3.38 × 0.59 in
(86 × 54 × 15 mm)
- Temperature:**
Operating:
14 °F to 158 °F (-10 °C to 70 °C)

Part Number/Price

Part #	Description	Price
187816	PROFINET IO interface kit for 920i indicator	\$895.00

Options/Accessories

Part #	Description	Price
187907	Additional operating manual	\$35.00

FIELDBUS CARDS
DeviceNet® Interface
 720i™/920i®

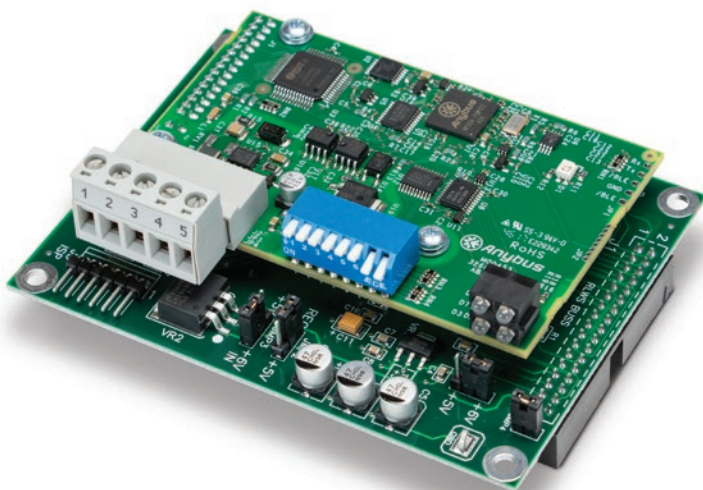

Part Number/Price

Part #	Description	Est. Weight	Price
68541	DeviceNet interface kit for 720i/920i indicators	3 lb	\$720.00

Options/Accessories

Part #	Description	Price
69949	Additional operating manual	\$44.00

Standard Features

- DeviceNet communication adapter
- Polled I/O connection
- 125 Kbps, 250 Kbps, and 500 Kbps baud rate
- Onboard LED diagnostics
- Floating-point commands support decimal points

Specifications

Power:
 5 VDC, 270 mA
 Fieldbus connector requires 24 VDC, ±10%

Communication Ports:
 Twisted-pair cabling at 125, 250, or 500 Kbps
 Update rate is dependent on the configured baud rate and the number of network modes

Fieldbus Interface:
 Pluggable screw connector

Diagnostic LEDs:
 Module status and network status

Galvanic Isolation:
 Bus power is separated from other electronics via DC/DC converter. The send and receive signals are isolated via opto couplers.

Dimensions:
 2.13 × 3.38 × 0.59 in
 (86 × 54 × 15 mm)

Temperature:
 Operating: 14 °F to 158 °F (-10 °C to 70 °C)

INDICATORS / CONTROLLERS

FIELDBUS CARDS
ControlNet® Interface
 920i®

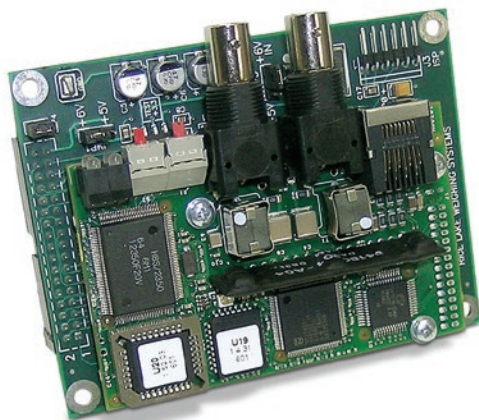

Part Number/Price

Part #	Description	Price
103136	ControlNet interface for 920i indicator	\$1,080.00

Cables
 Consult factory for coaxial cable with cord grips

Options/Accessories

Part #	Description	Price
103122	Additional operating manual	\$40.00

Standard Features

- Option for 920i®
- Polled I/O connection
- Onboard LED diagnostics
- Floating-point commands support decimal points

Specifications

Power:
 5 VDC, 350 mA (jumper for 6 VDC)

Fieldbus Interface:
 BNC connector

Diagnostic LEDs:
 Module status and network status

Dimensions:
 2.13 × 3.38 × 0.59 in
 (86 × 54 × 15 mm)

Temperature:
 Operating: 14 °F to 158 °F (-10 °C to 70 °C)

EtherNet/IP™ Interface

720i™/920i®



INDICATORS /
CONTROLLERS

Part Number/Price

Part #	Description	Price
87803	EtherNet/IP protocol card for 720i/920i indicators	\$895.00

Options/Accessories

Part #	Description	Price
88537	Additional operating manual	\$40.00

Standard Features

- Industrial protocol for Allen-Bradley PLC and other EtherNet/IP compliant devices
- IP address settings configurable with ip config utility, onboard DIP switches, web page, or ARP or DHCP
- Supports Rockwell Automation® EtherNet/IP level
- CE marked and UL conformance
- Onboard diagnostic LED
- Supports the Modbus TCP protocol and conforms to Modbus TCP specification 1.0

Specifications

Power:

5 VDC, 350 mA

Fieldbus Interface:

RJ-45

Diagnostic LEDs:

Module status and network status

Dimensions:

2.13 × 3.38 × 0.59 in
(86 × 54 × 15 mm)

Temperature:

Operating:
14 °F to 158 °F (-10 °C to 70 °C)

Ethernet TCP/IP Interface

720i™/920i®

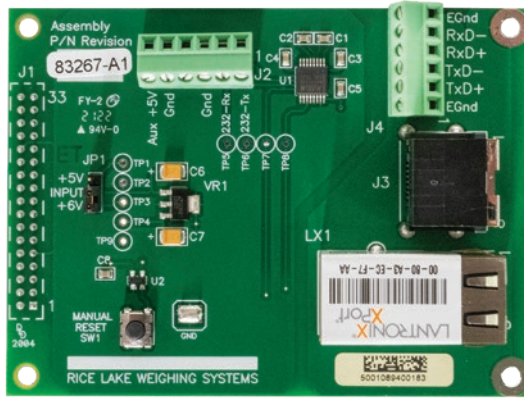

Standard Features

- Supports any serial devices with seven or eight data bits requiring Ethernet access
- Compact size for internal installation in 720i and 920i indicators
- Can be used in other applications requiring five-volt power supplied
- 10/100 megabyte through RJ45 connector or wireless option
- HTTP, serial, telnet and SNMP management

Specifications

Power:

5 VDC, 250 mA

Supported Protocols:

ARP, UDP, TCP, Telnet, SNMP, ICMP, HTTP, BOOTP, DHCP and TFTP

Network Interface:

Ethernet: RJ-45 (10/100 Base-T) or AUI

Serial Line Formats:

Characters: 7 or 8 data bits
Stop bits: 1 or 2
Parity: odd, even, none

Data Rates:

Single port, 300 bps to 115.2 Kbps default 9,600

Dimensions:

2.00 × 1.90 × 0.75 in
(52 × 49 × 19 mm)

Temperature:

Operating:
41 °F to 122 °F (5 °C to 50 °C)

Part Number/Price

Part #	Description	Est. Weight	Price
71986	Ethernet TCP/IP interface for 720i/920i indicators	3 lb	\$455.00
206271	Wireless Ethernet TCP/IP interface for 720i/920i indicators	3 lb	\$670.00
206272	Wireless Ethernet TCP/IP interface for 720i, CW-90 indicators and iQUBE ²	3 lb	\$610.00

Options/Accessories

Part #	Description	Price
72117	Additional operating manual	\$14.00
Cables		
72697	RJ-45 to RJ-45, straight, 7 ft length	\$40.00
78860	RJ-45 to RJ-45, cross over, 7 ft length	\$44.00



PN 206272



PN 206271

INDICATORS / CONTROLLERS

PROFIBUS® DP Interface

880™/882D/882IS/1280™



Standard Features

- DP intelligent device
- Standard GSD file download from product page
- Selectable addresses
- Up to 12 Mbps baud rate
- Onboard diagnostic LEDs

Specifications

Power:
3.3 VDC, 250 mA

Connector Type:
DB9, pluggable

Diagnostic LEDs:
Module status and network status

Dimensions:
2.00 × 1.90 × 0.75 in
(52 × 49 × 19 mm)

Temperature:
Operating:
-40 °F to 158 °F (-40 °C to 70 °C)

INDICATORS /
CONTROLLERS

Part Number/Price

Part #	Description	Est. Weight	Price
179163	PROFIBUS DP interface kit, for 880 indicator	1 lb	\$600.00
165795	PROFIBUS DP interface kit for 1280 indicator	1 lb	\$620.00
190534	PROFIBUS DP interface kit for 882D and 882IS indicators	1 lb	\$620.00

NOTE: Kit includes module and carrier board

Options/Accessories

Part #	Description	Price
156784	Additional operating manual	\$40.00

PROFINET Interface

880™/882D/882IS/1280™



Standard Features

- PROFINET communication adapter
- Onboard diagnostic LEDs
- 100 Mbps baud rate
- Works as an I/O device on the PROFINET network
- PROFINET compliant

Specifications

Power:
3.3 VDC, 250 mA

Configuration:
GSDML file

Connector Type:
RJ-45 (Consult for dual-port version)

Diagnostic LEDs:
Module status and network status

IP Address Range:
Full IP address range DHCP

Dimensions:
2.00 × 1.90 × 0.75 in
(52 × 49 × 19 mm)

Temperature:
Operating:
-40 °F to 158 °F (-40 °C to 70 °C)

Part Number/Price

Part #	Description	Est. Weight	Price
179160	PROFINET interface kit for 880 indicator (single port)	1 lb	\$600.00
205567	PROFINET interface kit for 880 indicator (dual port)	1 lb	\$805.00
165794	PROFINET interface kit for 1280 indicator (single port)	1 lb	\$620.00
190532	PROFINET interface kit for 882D and 882IS indicators	1 lb	\$620.00

NOTE: Kit includes module and carrier board

Options/Accessories

Part #	Description	Price
156781	Additional operating manual	\$40.00

DeviceNet® Interface

880™/882D/882IS/1280™



Standard Features

- DeviceNet communication adapter
- 125 Kbps, 150 Kbps and 500 Kbps baud rate
- Onboard diagnostic LEDs

Specifications

- Power:**
3.3 VDC, 250 mA
- Connector Type:**
Pluggable screw terminal
- IP Address Range:**
MAC ID 0 to 63
- Diagnostic LEDs:**
Module status and network status
- Dimensions:**
2.00 × 1.90 × 0.75 in
(52 × 49 × 19 mm)
- Temperature:**
Operating:
-40 °F to 158 °F (-40 °C to 70 °C)

Part Number/Price

Part #	Description	Est. Weight	Price
179162	DeviceNet interface kit for 880 indicator	1 lb	\$600.00
165793	DeviceNet interface kit for 1280 indicator	1 lb	\$620.00
190531	DeviceNet interface kit for 882D and 882IS indicators	1 lb	\$620.00

NOTE: Kit includes module and carrier board

Options/Accessories

Part #	Description	Price
156783	Additional operating manual	\$40.00

INDICATORS / CONTROLLERS

Modbus TCP Interface

880™/882D/882IS/1280™



Standard Features

- Active module with serial and parallel application interface
- Complete Modbus TCP server
- Up to eight bytes of I/O data
- Transformer isolated interface 100 Mbps full duplex Ethernet
- Onboard diagnostic LEDs
- CE and UL compliant

Specifications

- Power Requirements:**
3.3 VDC, 250 mA
- Connector Type:**
RJ-45
- Diagnostic LEDs:**
Link status, network status, module status
- Dimensions:**
2.00 × 1.90 × 0.75 in
(51 × 48 × 19 mm)
- Temperature:**
Operating: -40 °F to 176 °F (-40 °C to 85 °C)

Part Number/Price

Part #	Description	Est. Weight	Price
179161	Modbus TCP Interface kit for 880 indicator (single port)	1 lb	\$600.00
205568	Modbus TCP Interface kit for 880 indicator (dual port)	1 lb	\$805.00
165796	Modbus TCP Interface kit for 1280 indicator (single port)	1 lb	\$620.00
190533	Modbus TCP Interface kit for 882D and 882IS indicators	1 lb	\$620.00

NOTE: Kit includes module and carrier board

Options/Accessories

Part #	Description	Price
156782	Additional operating manual	\$40.00

EtherNet/IP™ Interface

880™/882D/882IS/1280™



Standard Features

- Industrial protocol for Allen-Bradley® PLC and other EtherNet/IP compliant devices
- IP address settings configurable with ip config utility, web page, ARP or DHCP
- Supports Allen-Bradley EtherNet/IP
- Onboard diagnostic LEDs
- CE marked and UL conformance
- AOP (880 only) or standard EDS file download

Specifications

Power Requirements:

3.3 VDC, 250 mA

IP Address Range:

Full IP address range

Connector Type:

RJ-45

Diagnostic LEDs:

Module status and network status

Dimensions:

2.00 × 1.90 × 0.75 in
(52 × 49 × 19 mm)

Temperature:

Operating:
-40 °F to 158 °F (-40 °C to 70 °C)

INDICATORS /
CONTROLLERS

Part Number/Price

Part #	Description	Est. Weight	Price
179159	EtherNet/IP interface kit for 880 indicator (single port)	1 lb	\$600.00
205566	EtherNet/IP Interface kit for 880 indicator (dual Port)	1 lb	\$805.00
165792	EtherNet/IP interface kit for 1280 indicator (single port)	1 lb	\$620.00
208129	EtherNet/IP Interface kit for 1280 indicator (dual Port)	1 lb	\$805.00
190530	EtherNet/IP Interface kit for 882D and 882IS indicators	1 lb	\$620.00

NOTE: Kit includes module and carrier board

Options/Accessories

Part #	Description	Price
156861	Additional operating manual	\$40.00

EtherCAT® Interface

880™/882D/882IS/1280™



Standard Features

- Two RJ-45 EtherCAT 100 Mbit/s ports available simultaneously
- Can be wired in several topologies including star, line or tree
- Has built-in redundancy that compensates for potential breaks in wiring
- No network switches necessary, can be wired directly from device to device
- Includes self-terminating network
- Onboard diagnostic LEDs
- CE, cULus and RoHS compliant

Specifications

Power:

3.3 VDC, 500 mA

Connector Type:

RJ-45 (dual port)

Diagnostic LEDs:

Module status and network status

Dimensions:

2.04 × 1.97 × 0.86 in
(52 × 50 × 22 mm)

Temperature:

Operating:
-40 °F to 158 °F (-40 °C to 70 °C)

Part Number/Price

Part #	Description	Est. Weight	Price
179158	EtherCAT interface kit for 880 indicator	1 lb	\$600.00
179533	EtherCAT interface kit for 1280 indicator	1 lb	\$620.00
190535	EtherCAT interface kit for 882D and 882IS indicators	1 lb	\$620.00

NOTE: Kit includes module and carrier board

Options/Accessories

Part #	Description	Price
164394	Additional operating manual	\$40.00



Part Number/Price

Part #	Description	Est. Weight	Price
MSI-7000			
227549	Four-channel, transmitter, 85-265 VAC, load cell, w/3 relays	2 lb	\$1,525.00
227550	Four-channel, receiver, 85-265 VAC, digital, w/3 relays	2 lb	\$1,350.00
MSI-7001			
230905	Single-channel, transmitter, 85-265 VAC, load cell input	2 lb	Consult
230951	Single-channel, receiver, 85-265 VAC, mV output	2 lb	Consult
230952	Single-channel, receiver, 85-265 VAC, RS232 output	2 lb	Consult

Options/Accessories

Part #	Description	Price
143531	Power cord, 6 V SLA battery charger EU	\$33.00
143533	Power cord, 6 V SLA battery charger, Australia	\$54.00
143534	Power cord, 6 V SLA battery charger, UK	\$49.00
162178	Antenna extension kit, 6 ft coax cable	\$535.00
150964	RS-232 13 ft (4 m) serial cable with nine-pin (female) connector, MSI-7001	\$220.00
150965	RS-232 13 ft (4 m) serial cable with nine-pin (male) connector, MSI-7001	\$180.00
145085	RS-232 serial cable, unterminated, MSI-7000	\$145.00
148624	Cable assembly, RS232/485 to DB9, used for setup and calibration	\$150.00
144400	Cable assembly, 4-pin, female, 4 meter, mV	\$110.00
145084	Cable assembly, 4-pin, female, 2 meter, mV	\$64.00
162177	Cable assembly, 4-pin, male, 2 meter, A2D cable, MSI-7001	\$145.00
162184	Connector, M12, 4-pin, straight, mV, MSI-7001	\$65.00
162185	Connector, M12, 4-pin, right-angle, mV, MSI-7001	\$65.00

Standard Features

- Works with any basic digital weight indicator
- Excitation to load cell(s) provided by the transmitter, not the indicator
- Each transmitter/receiver set is individually paired
- Serial communication cable included

Options

(Contact MSI for application consultation)

- Multiple antenna selections
- Analog output
- Additional VDC input power

Specifications

Power:

85 to 265 VAC

Excitation Voltage:

Transmitter: +4.8 VDC, 16 × 350 ohm or 32 × 700 ohm load cells

Standard Antenna:

1/2 wave 2dBi, articulated

Frequency:

Spread spectrum at 2.4 GHz, 802.15.4

Effective Range:

Typically 100 to 300 ft, line of sight; for longer range consult factory

Communication Ports:

Full duplex RS-232

Circuit Protection:

RFI, EMI, ESD protection

Temperature:

Operating:
-40 °F to 185 °F (-40 °C to 85 °C)

Rating/Material:

IP68, die-cast aluminum enclosure

Additional RF Options:

Wi-Fi
802.15.4
FHSS

Warranty:

One-year limited

INDICATORS / CONTROLLERS



Standard Features

- Works with any basic digital weight indicator
- Excitation to load cell(s) provided by the transmitter, not the indicator
- Each transmitter/receiver set is individually paired and will not interfere with another set
- RS-232 cable included with transmitter and paired set

Specifications

- Power:**
5 to 6 VDC
- Excitation Voltage:**
Transmitter: +4.8 VDC, 16 × 350 ohm or 32 × 700 ohm load cells
- Frequency:**
Direct sequence spread spectrum at 2.4 GHz, 802.15.4 license free
- Standard Antenna:**
1/2 wave 2dBi, articulated
- Effective Range:**
Typically, 100 to 300 ft
For longer range, consult factory
- Circuit Protection:**
RFI, EMI, ESD protection
- Communication Ports**
Full duplex RS-232
- Temperature:**
-40 °F to 185 °F (-40 °C to 85 °C)
- Rating/Material:**
NEMA Type4 (IP66), aluminum black powder coated (excludes wall cube model)
- Warranty:**
Two-year limited

Part Number/Price

Part #	Description	Est. Weight	Price
Transmitters			
5 to 6 VDC Power Input			
160331	Single-channel transmitter, 5 to 6 VDC no relays. RF 802.15.4, 2.4 GHz 5 to 6 VDC	2 lb	\$1,075.00
Receivers			
5 to 6 VDC Power Input			
160338	Receiver to provide a mV signal to a digital weight indicator. RF 802.15.4, 2.4 GHz 5 to 6 VDC power input	2 lb	\$1,150.00
Paired Set			
5 to 6 VDC Power Input			
165312	Includes one single-channel transmitter and one receiver, paired. Includes an RS-232 cable, a 2 m load cell cable and 2 m indicator cable/power source sold separately	5 lb	\$2,350.00

Options/Accessories

Part #	Description	Price
162172	Charger, SendIt 6 V SLA battery	\$73.00
162173	Battery, SendIt 6 V SLA	\$155.00
162175	Enclosure, SendIt for 6 V SLA battery	\$385.00
145548	Cord set, 13 ft (4 m)	Consult
150964	RS-232 13 ft (4 m) serial cable with nine-pin (female) connector	\$220.00
150965	RS-232 13 ft (4 m) serial cable with nine-pin (male) connector	\$180.00
160109	AC adapter, SendIt 6V	\$62.00
162177	Cordset. Pre-wired for use with single channel transmitters or non-relay based receivers	\$145.00
162184	Load cell connector. Field wireable, 4 to 6 mm straight. For use with single channel transmitters	\$65.00
162185	Load cell connector. Field wireable, 6 to 8 mm straight. For use with single channel transmitters	\$65.00
162186	Load cell connector. Field wireable, 4 to 6 mm right angle. For use with single channel transmitters	\$65.00
162187	Load cell connector. Field wireable, 6 to 8 mm right angle. For use with single channel transmitters	\$65.00
162178	Antenna kit, remote standard antenna, 5 ft	\$535.00



Paired Radios

Standard Features

- Durable industrial-grade enclosure with mounting flanges
- Reliable communications up to 115 to 200 kbps
- Supports point-to-point and point-to-multipoint applications

Specifications

Power:

Line voltage: 100 to 120 V
 Frequency: 50/60 Hz (240 V outside the US)
 Input: 7 to 18 VDC
 Output: 5 to 1,000 mW variable

Power Supply:

AC transformer via 6 ft cable (183 cm)

Frequency Band:

902 to 928 MHz

Modulation:

FHSS FSK

Interface:

Standard: RS-232
 ConnexLink PRO: RS-485

Serial Interface Data Rate:

Up to 115 to 200 kbps

Current Draw (at 12 VDC):

RF: Standard ConnexLink: 400 mA
 Pro: 325 mA TX, 20 mA RX

Antenna Connector:

Reverse polarity SMA jack (female)

Channels:

32 selectable channels

Security:

1-byte system ID, DES

Sensitivity:

-99dB at full RF data rate

Range (line-of-sight):

Up to 20 miles (32 km)

Dimensions:

4.75 × 2.75 × 1.17 in
 (121 × 70 × 30 mm)

Temperature:

Operating: -40 °F to 176 °F (-40 °C to 80 °C)

Humidity:

10% to 90% non-condensing

Weight:

< 6 oz (< 170 g)

INDICATORS /
 CONTROLLERS

Part Number/Price

Part #	Description	Price
86134	ConnexLink RF device 900 MHz RF device server/client (requires minimum of 2)	\$365.00
105776	ConnexLink Pro 900 MHz 1W, wireless transceiver with large buffer	\$450.00
110538	ConnexLink FRP enclosure with heater	\$1,565.00
110539	ConnexLink Pro enclosure with heater	\$1,565.00
129662	Paired ConnexLink	\$735.00

Options/Accessories

Part #	Description	Price
78827	Power supply, 115 VAC input/6 VDC output	\$65.00
103979	Antenna 1/2 Wave, 2 dBi, 7 in for 900 MHz radios	\$55.00
119448	Yagi antenna	\$165.00
119449	Cable, Yagi antenna 20ft*	\$95.00
22436	RS-232 nine-pin female to blunt end	\$77.00
98084	DC power cable option	\$15.75

* max length per manufacturer specs

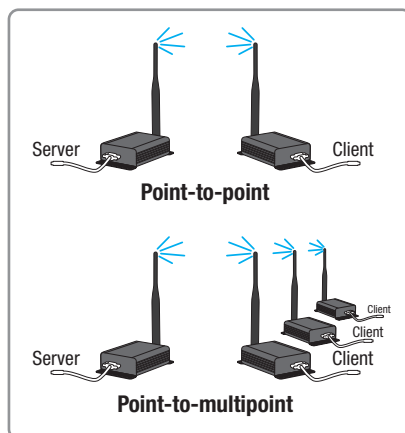

Industrial Broadband

Wireless Ethernet

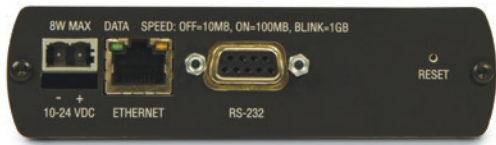

Standard Features

- Serial and Ethernet connectivity
- Configures as 802.11 a/b/g access point, wireless bridge, wireless repeater and client
- Secure WPA2/128 bit encryption
- Dual band 2.4 GHz or 5 GHz bands
- Robust design for extreme temperatures (-40 °C to 75 °C) high vibration/shock and hazardous locations (UL Class 1, Division 2, Atex Zone 2)

Specifications

Frequency Band (varies by country):

- 2.412 GHz to 2.462 GHz (FCC)
- 2.412 GHz to 2.472 GHz (ETSI)
- 5.150 GHz to 5.250 GHz (FCC/ETSI)
- 5.725 GHz to 5.850 GHz (FCC)

Wireless Standards:

802.11a, 802.11b, 802.11g and 802.11i

Programmable (varies by country):

- 2.4 GHz: up to 100 mW (20 dBm)
- 5 GHz: up to 64 mW (18 dBm)

Channel Data Rates (modulation):

- 802.11b: 11, 5.5, 2, 1 Mbps (DSSS, BPSK, QPSK, CCK)
- 802.11g: 54, 48, 36, 24, 18, 12, 9, 6 Mbps (OFDM)
- 802.11a: 54, 48, 36, 24, 18, 9, 6 Mbps (OFDM)

Receiver Sensitivity (Typical):

- 90 dBm at 1 Mbps
- 85 dBm at 11 Mbps
- 82 dBm at 24 Mbps
- 75 dBm at 54 Mbps

Channels Selection (varies by country):

1 to 13 (802.11a)

Security:

WPA2 - 802.11i with 128 bit AES-CCM legacy WPA TKIP, WEP support MAC ID filter, admin password

INDICATORS / CONTROLLERS

Part Number/Price

Part #	Description	Price
166630	Industrial hot spot, 802.11a/b/g*	\$2,155.00
161954	Industrial hot spot in FRP enclosure*	\$3,195.00
161955	Paired radios for serial data tunneling*	\$4,325.00

*Special ordered power supplies and antennas required

Dimensions

FRP Enclosure			
A	8.5 in (216 mm)	B	10.5 in (267 mm)



161954 Industrial hot spot

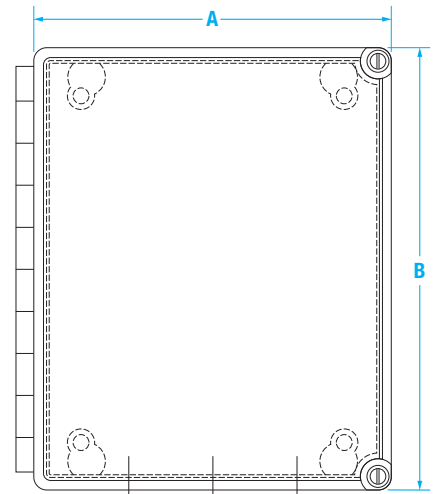

Ubiquiti® NanoStation®



- Ethernet wireless bridge
- 5 GHz operating frequency
- RJ45 network interface
- PoE 2-pair (4, 5+; 7, 8 return) power method
- 24 V, 0.3 A gigabit PoE supply included
- 22 to 27 VDC voltage range
- Temperature: -40 °F to 158 °F (-40 °C to 70 °C)
- Humidity: 5% to 95% non-condensing

Part Number/Price

Part #	Description	Price
204477	Nanostation	\$395.00

Visible Lights and Audible Alarms

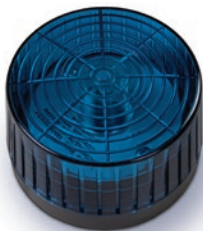

Blue strobe
(reference photo only)

Product may vary from photo



Buzzer
(reference photo only)

Part Number/Price

Part #	Description	Price
Visible Lights and Audible Alarms		
22838	Buzzer, 80 dB, steady	\$145.00
22839	Buzzer, 80 dB, pulse	\$145.00
156106	Buzzer box, 115 VAC, FRP enclosure	\$795.00
43931	Strobe lights, red	\$225.00
43930	Strobe lights, amber	\$225.00

Manual Pushbuttons/Pushbutton Switches



- Key switches
- Lighted pushbuttons
- Pilot lights
- Two- and three-position switches
- Colored pushbuttons
- Emergency stop mushroom switches
- Custom legend plates

Part Number/Price

Part #	Description	Price
Manual Pushbuttons/Pushbutton Switches		
Consult	Operator and contact block combinations	Consult

INDICATORS /
CONTROLLERS

USB to Serial Converter/Adapter

Serial Adapters



Standard Features

- Portable design—no AC power required
- Supports data transfer rates of more than 500 kbps
- Hot swappable

Specifications

Data Transfer Rate:

More than 500 kbps

LED:

Data transfer/handshaking (orange)

Power Consumption:

450 Mw USB

Specifications:

V1.1 compliant

INDICATORS /
CONTROLLERS

Part Number/Price

Part #	Description	Est. Weight	Price
178501	Adapter, USB Serial FTDI US232R-100, 3.28 ft, iDim Series for use with Rice Lake indicator and Postal Scales	-	\$60.00
22436	Cable DB9F to blunt end, 6 ft	1 lb	\$77.00

DB-9 PIN Assignments:

PIN	Assignment	PIN	Assignment
1	CD	6	DSR
2	RXD	7	RTS
3	TXD	8	CTS
4	DTR	9	RI
5	GND		

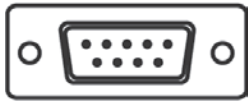

DB9 (Male) Connector

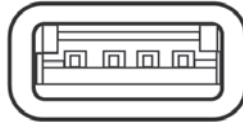

Type A USB Connector

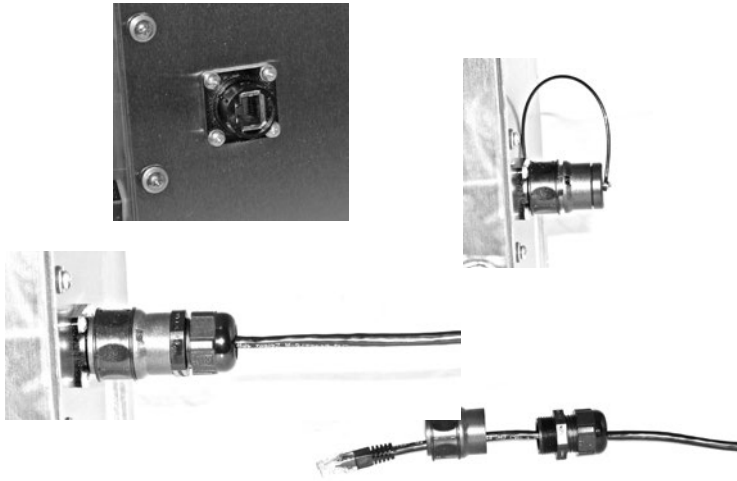

Standard Features

- Allows an Ethernet Class D/Category 5e connection for 10Base-T, 100Base-TX, or 1000Base-T networks in harsh environments
- Sealed against fluids and dusts (IP67)
- Shock, vibration and traction resistant
- No cabling operation in the field
- No tools required
- Improved EMI protection
- Uses a standard RJ-45 cordset in protective composite plug to protect from shocks, dust and fluids
- In-field cabling and grounding not necessary

Specifications

Data Transmission:

10Base-T, 100Base-TX and 1000Base-T networks
 Category 5e per TIA/EIA 568B and ClassD per ISO/IEC 11801

Mechanical:

Quick push/pull coupling
 RJ-45 cordset retention in the plug: 100N in the axis
 Mating cycles: 500 min

Environmental Protection:

Sealing: IP67
 Salt Spray: > 1000h
 Fire retardant/low smoke: UL94 V0 and NFF 16 16102, DIN 5510-2
 Vibrations: 10 to 500 Hz, 10g, 3 axes:
 no discontinuity > 10 nanos
 Thermal Shock: 5 cycles at -40 °C / +100 °C

Temperature:

Operating:
 -40 °F to 185 °F (-40 °C to 85 °C)

Applications:

Telecom equipment, video control, robotics,
 industrial process control, CNC machines, motion
 control, tele-maintenance

Part Number/Price

Part #	Description	Price
87326	RJF 544 kit	\$200.00
87285	Square flange female connector	\$45.00
87286	Dust cap for harsh environment receptacles	\$55.00
87287	Gasket for harsh environment receptacles	\$5.25
87288	Ethernet plug	\$45.00
87289	Dust cap for harsh environment plugs	\$65.00



Standard Features

- Converts serial data such as bar code reader or scale into keyboard input to software program
- Works with PC and MAC® computers
- Requires no driver installation (identifies itself as additional HID keyboard)
- Cable draws power from USB port (no external power supply needed)
- Test cable to be connected with adapter scale cable or connector
- WPAN version allows connection to devices such as iPad® or Android® tablets and phones

Specifications

Power:
USB power, no external power supply

Baud Rate:
9600

Color:
Black

Cable Length:
74 in (1,880 mm)

Bluetooth Cable Length:
16 in (406 mm)

Host:
PC and MAC compliant

Connection:
DB9 male connector

Pin Out:
Pin 2: RX
Pin 3: TX
Pin 5: Ground USB-A

Part Number/Price

Part #	Description	Est. Weight	Price
119919	RS-232/USB serial cable	1 lb	\$190.00
132452	RS-232/USB serial cable plus Bluetooth®	1 lb	\$275.00

Options/Accessories

Part #	Description	Price
119064	Slimline null modem, gender changer DB9 female to female	\$14.00
22436	Blunt-end to DB9 female, straight cable	\$77.00
50749	DB9 female to DB9 female	\$66.00
130789	Null model DB9 adapter female to male	\$16.00



Standard Features

- LED onboard for testing data transmission
- Captures data and stores it on a USB flash drive (up to 8 GB not included)
- Transfer data to your PC using the USB flash drive
- Text file examples (actual text will be dependent on transmitted file)
- 02:50PM
11/13/2012
GROSS 58 lb
- 02:50PM
11/13/2012
GROSS 68 lb

Specifications

Power:
Requires 5 VDC, 2 A

Baud Rate:
9600

Data Bits:
8

Parity:
None

Customer Supplied:
Power and USB flash drive

Industrial Enclosure Option:
7.5 × 7.5 × 4.5 in
(19 × 19 × 12 cm)
Latch for lock

Warranty:
One-year limited

INDICATORS / CONTROLLERS

Part Number/Price

Part #	Description	Price
153265	go-between board	\$435.00
153266	go-between industrial enclosure	\$630.00
153267	go-between desk enclosure	\$525.00
158778	go-between desk enclosure, EU power supply	\$525.00

Options and Accessories

Part #	Description	Price
154797	Adapter, power 5 VDC 2A 90-264 VAC, U.S. plug, UL/cUL	\$37.00
170935	Overlay, desk	\$79.00

