

Stainless Steel, Environmentally Sealed, NTEP Certified Single Cell 1:5,000 III/1:10,000 IIIL, IP67

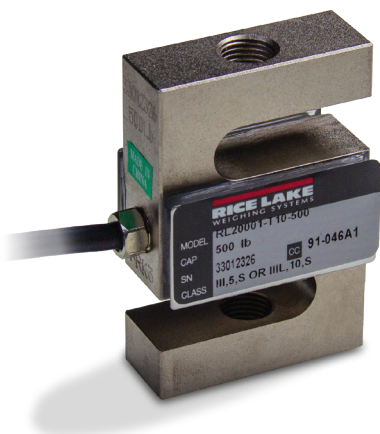

Approvals

Measurement
Canada
Approved

Order Information

Picture is a representation of actual product

Load Rating	Part #	Est. Weight	Price
5,000 lb	215390	4 lb	Consult

Options/Accessories

Part #	Description	Price
96196	Wrench for CLS forklift scale	Consult
125543	RL20000FLS with automotive connection	Consult
203139	Replacement kit includes flexure rods, jam nuts and washers	Consult

Dimensions

Rated Capacity	A	B	C	D	E
5,000 lb/in	1/2-20 UNF	1.25	1.00	3.00	4.00

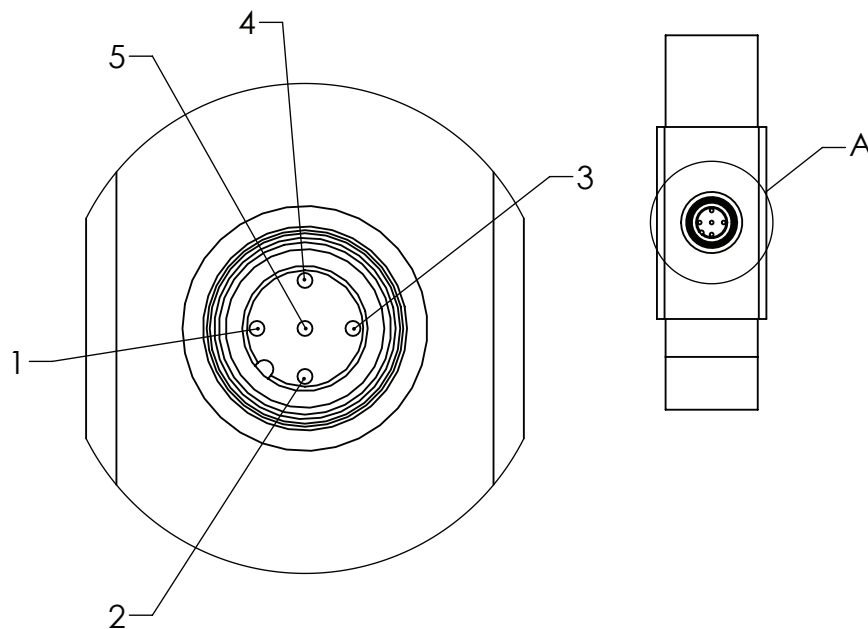

Specifications

Full Scale Output:

1.5 mV/V

Output Resistance:

350 (±3.5) ohm

Input Resistance:

430 (±60) ohm

Material/Finish:

Stainless steel

Temperature:

Compensated Range

14° F to 104° F (-10° C to 40° C)

Operating Range

0° F to 150° F (-18° C to 65° C)

Seal Type:

Environmentally sealed, IP67

Safe Overload:

150% full scale

Rated Excitation:

5-10 VDC (15 V maximum)

Combined Error:

0.02% full scale

Insulation Resistance:

5,000 megohms at 50 VDC

Cable Length:

30 in

Wire Color Code:

Red +Excitation (Pin 3)

Black -Excitation (Pin 4)

Green +Signal (Pin 1)-

White -Signal (Pin 2)

Yellow Shield (Pin 5)

Warranty:

Two-year limited warranty

Approvals:

NTEP