

Operating Manual

Minebea Intec Signum[®] 3 Ex

Model SIWXSBBP | SIWXSBBBS | SIWXSDCP | SIWXSDCS Complete Scales
for Use in Explosive Atmospheres

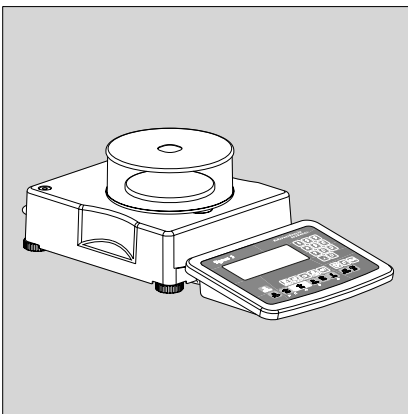
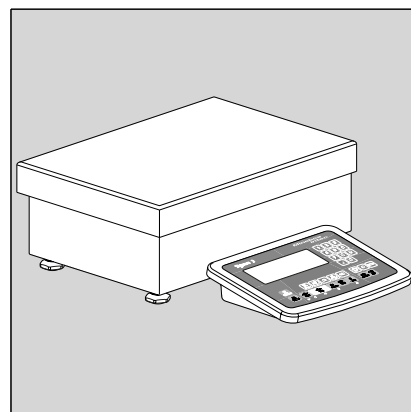
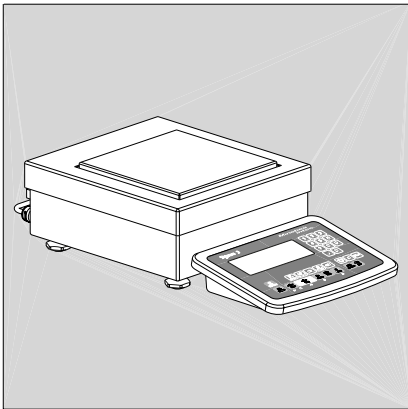
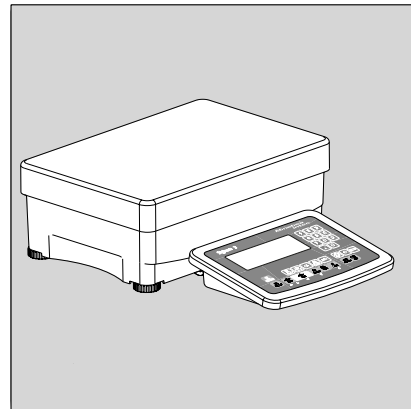
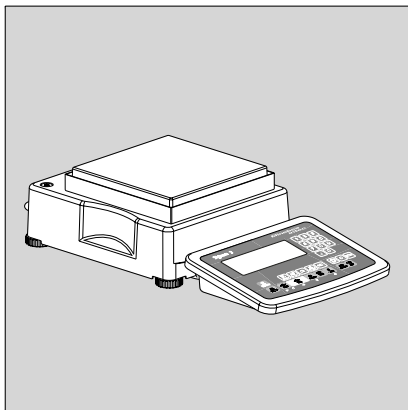

Contents

Contents	2	Configuration.....	15	Configuring Printouts	76
Intended Use.....	3	Setting the Language	15	Configuring the Product Data Memory..	78
Warning and Safety Instructions.....	4	Configuring a Password	16	Data Interface	79
Getting Started.....	4	Operating Menu Overview	17	Pin Assignment Chart	80
Unpacking the Scale.....	4	Operation	34	Pin Assignments for COM1	80
Equipment Supplied	4	Basic Weighing Function	34	Configuring the Data Interface	
Installation	4	Weighing $\Delta\Delta$	34	as a COM Interface	81
Acclimatization.....	4	Device Parameters	34	Data Input Format (Command)	81
Installing the Display and Control Unit	5	Tare Function in Weighing	36	Data Output Format	82
Connecting the Device to AC Power	7	Numeric Input for Weighing.....	36	Configuring the Data Interface	
Leveling the Weighing Platform.....	7	Weighing with Variable Tare Values	37	as a Printer Interface.....	83
General View of the Equipment	8	Calibration and Adjustment	38	Automatic Data Output (SBI).....	84
Display and Keypad	8	Legal Metrology.....	38	GMP-compliant Printouts.....	85
Back Panel	8	Internal Adjustment	39	Error Codes	86
Operating Concept.....	9	Setting / Deleting the Preload	39	Care and Maintenance.....	87
Keypad	9	External Calibration	41	Disposal.....	87
Keypad Input.....	9	SQmin Function	42	Common Specifications.....	88
Input Through the Digital Control Port ..	10	Individual ID Codes (Identifiers)	44	Signum® Model Designator	88
Display Modes	11	Combining Application Programs.....	46	Model-specific Specifications	89
Measuring Range Display.....	12	Counting.....	47	Dimensions (Scale Drawings).....	91
Saving Data in Weighing Mode	14	Neutral Measurement.....	51	Accessories	94
Operating Menu Navigation	13	Averaging	54	Declaration of Conformity.....	97
Error Codes	14	Weighing in Percent	60	Certificates	99
Data Output.....	14	Checkweighing	65	FM/CSA Certificate.....	107
Saving Data.....	14	Checkweighing Toward Zero	63	Control drawing	114
		Classification	64	Verification of intrinsic safety.....	117
		Totalizing	67	Data output options.....	125
		Net-total Formulation	70	Power supply options	131
		Examples of Application		Safety Instruction	132
		Combinations in Signum® 3	74	General Password.....	133

Intended Use

Signum[®] 3 is a precise and rugged complete scale that gives you reliable weighing results.

The Signum[®] Series of compact scales includes models with monolithic technology, using the principle of electro-magnetic force compensation.

These compact industrial scales offer the following special features:

- Rugged and durable Minebea Intec quality
- Flexible options for display unit installation
- Wide range of configuration options for customized operation
- Variety of optional data interfaces
- Optional IP65 protection from dust and jets of water (SIWXS***-06: IP 43)
- High quality workmanship and materials
- Various application programs
- Available in weighing capacities between 0.6kg and 35kg; choice of resolutions available for each capacity

- Preload values can be defined (for equipment installed on the scale)
- Display can be decoupled from the weighing technology
- Use in potentially explosive atmospheres, zones 1 /21 (SIWXS***-06: Ex Zone 1)

Additional features include:

- large keys with positive click action
- Numeric and alphabetic input
- Large backlit 14-segment display

Advantages in routine weighing tasks:

- Fast response times
- Independence from location of platform installation
- Designation of weight values with up to 4 lines of alphanumeric text
- Security through password protection

Range of Models

Signum[®] Supreme

SIWXSDCP models:

- Monolithic weighing system
- Resolutions up to 350,000d

SIWXSBBP models:

- Monolithic weighing system
- Resolutions up to 620,000d

Signum[®] Supreme featuring a stainless steel housing

SIWXSDCS/SIWXSBBBS models:

- Monolithic weighing system
- Resolutions up to 610,000d

Explanation of Symbols

The following symbols are used in the text:

- Denotes general operating instructions
- special instructions for exceptional cases
- > Describes the outcome of an operating step
- ⚠ Indicates a hazard

Technical Advice on Applications/
Hotline

Phone: +49.40.67960444

Fax: +49.40.67960474

E-mail: technical.support.hh@minebea-intec.com

Warning and Safety Instructions

Signum scales comply with the European Council Directives as well as international regulations and standards for electrical equipment, electromagnetic compatibility, and the stipulated safety requirements.

- Read these operating instructions thoroughly before using your scale. That way you will prevent damage to the equipment.

⚠ Please observe the safety instructions, of these operating instructions!

⚠ The display and control unit may only be opened by authorized service technicians who have been trained by Minebea Intec and who follow Minebea Intec's standard operating procedures for maintenance and repair work.

⚠ Make absolutely sure to unplug the display and control unit from the power supply before you connect or disconnect any electronic peripheral devices to or from the interface port.

⚠ The requirements pertaining to applicable installation regulations must be followed when using electrical equipment in systems and environmental conditions with increased safety requirements.

- Disconnecting the ground conductor is prohibited

- Note on installation:
The operator shall be responsible for any modifications to Minebea Intec equipment and for any connections of cables or equipment not supplied by Minebea Intec and must check and, if necessary, correct these modifications and connections.
Information on operational quality is available on request from Minebea Intec (in line with norms pertaining to immunity).

- If there is visible damage to the equipment or power cord, disconnect the system from the power supply and secure it against further use.

- Connect only Minebea Intec accessories and options, as these are optimally designed for use with your Signum scale.

- Do not unnecessarily expose the device to aggressive chemical vapors or to extreme temperatures, moisture, shocks, or vibration.

- Clean your Signum scale only in accordance with the cleaning instructions (see "Care and Maintenance").

- If you have any problems with your Signum scale: Contact your local Minebea Intec office, dealer or service center.

IP Protection:

- The IP43 (or optional IP65) protection rating for the display and control unit is ensured only if the rubber gasket is installed and all connections are fastened securely (including the caps on unused sockets).
The system and equipment must be installed and tested by a certified technician.

- If you install an interface port after setting up your Signum, keep the protective cap(s) in a safe place to be used for protecting the interface port when not in use, or prior to shipment. Do not leave the interface port uncovered.
Please observe the safety instructions, drawing 36953-750-16 in the appendix of these operating instructions!
If you are not using a particular connector, replace the cap to protect the data interface from vapors, moisture and dust or dirt.

Using the Equipment in Legal Metrology:

- If the scale is to be verified, make sure to observe the applicable regulations regarding verification.
- If any of the verification seals are damaged, make sure to observe the national regulations and standards applicable in your country in such cases. In some countries, the equipment must be re-verified.

Getting Started

Unpacking the Scale

- After unpacking the equipment, please check it immediately for any external damage.
- If you detect any damage, proceed as directed in the chapter entitled "Care and Maintenance" under "Safety inspection."
- Save the box and all parts of the packaging for any future transport. Unplug all connected cables before packing the equipment.

Equipment Supplied

- Complete scale
- Operating instructions
- Special accessories as listed on the bill of delivery, if ordered

Installation

Choose a location that is not subject to the following negative influences:

- Heat (heater or direct sunlight)
- Drafts from open windows and doors
- Extreme vibrations during weighing
- Extreme humidity

Acclimatization

Moisture in the air can condense on cold surfaces whenever the equipment is moved to a substantially warmer place. Allow the device to acclimatize for about 2 hours at room temperature, leaving it unplugged from the power supply.

Equipment Not In Use

Switch off the equipment when not in use.

Getting Started

Installing the Display and Control Unit

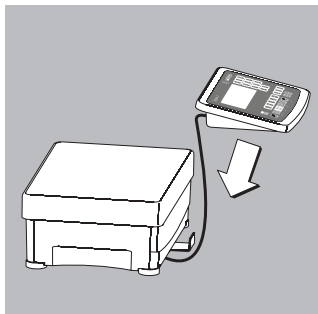

The following options are available for installing the display and control unit: (the pictures depict the SIW*DCP model)

- Fastening the display and control unit to the weighing platform:
- Guide the display and control unit onto the retainer bracket.
- Level the weighing platform (see page 7).

- Attached to the weighing platform
- On the YDH01P column: optional for the DCP model
- On the YDH02P column: optional for the BBP model
- On the YDH0xCWS column: optional for the DCS model
- On the YDH02S column: optional for the BBS model

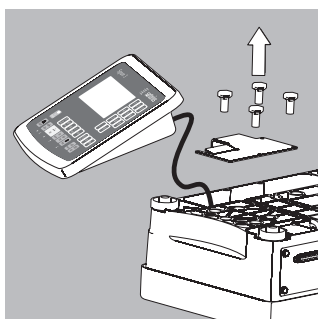

Operating the display and control unit separately:

- Turn the weighing platform over and place it on a soft surface to avoid damaging the weighing system.
- Remove the display and control unit retainer bracket.
- Take the cable out of the cable channel.
- Turn the weighing platform right-side up and place it so that it rests on its feet.
- Level the weighing platform (see page 7).

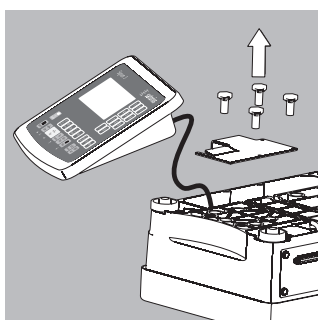

Installing the display and control unit on the YDH01P column:

- Turn the weighing platform over and place it on a soft surface to avoid damaging the weighing system.
- Remove the display and control unit retainer bracket.
- Take the cable out of the cable channel.

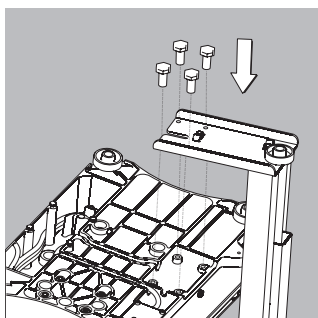

- Use the four hexagonal screws provided (M4+8) to attach the column to the weighing platform (back panel facing downward).
- Turn the weighing platform right side up and place it so that it rests on its feet.

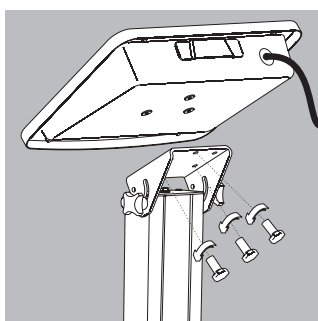

- Loosen the two locking bolts at the top of the column to facilitate installation of the display and control unit.
- Use the three hexagonal screws (M4x8) to attach the display and control unit to the top of the column.
- Adjust the display and control unit to the desired angle and secure it there.
 - This is done by tightening the locking bolts on the top of the column.

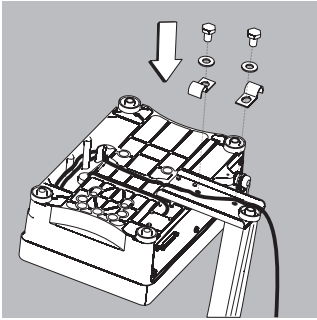

- A recessed space is provided in the scale base, accessed from the bottom of the scale, for any excess length of cable (connecting cable between display and control unit and weighing platform).
- Guide the connecting cable along the channel on the bottom of the weighing platform.
- Use the cable clamps provided to affix the cable that connects the display and control unit to the weighing platform to the bottom of the column.
- Turn the weighing platform right-side up and place it so that it rests on its feet.

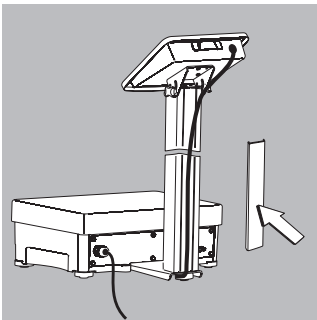

- Attach the cable retainer to affix the cable connecting the display and control unit to weighing platform to the back of the column.

SIWXSBB5 Installing the Display and Control Unit:

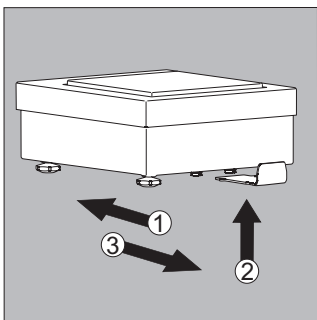

- 1 Slide the bracket under the weighing platform
- 2 Press up into the openings.
- 3 Pull the bracket forward to lock into place.

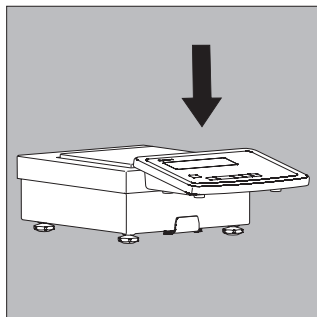

- Hang the display and control unit on the bracket

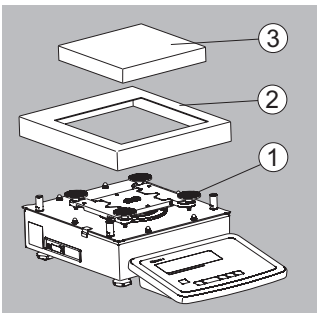

- Please observe the Verification of Intrinsic Safety, 36953-750-60 when connecting other electrical equipment to the Signum 3.

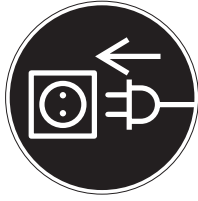

Connecting the Device to AC Power

- ⚠ Before startup, make sure that the power cable is properly connected to the power supply. In particular, the protective conductor must be connected to the housing of the adapter. Connect all devices via their equipotential bonding conductor terminals to the equipotential bonding conductor. Installation must be carried out properly by trained personnel and according to commonly accepted technical standards.
- ⚠ The system should only be operated for the first time when it is certain that the area is not potentially explosive. If deviations are evident during startup due to transport damage, the system should be disconnected from the power supply and Service should be contacted (no display, no backlighting despite weight value display, no reproducibility of the weight value, no stability in the display, etc.)
- ⚠ YPS02-X.. Pressure-enclosed Adapter:
 - Both cables should be laid fixed
 - Flexible cabling with screws available upon request
- ⚠ Check the supply voltage/frequency and plug design.
 - If they do not match: Contact your supplier
- ⚠ Use only an original AC adapter:
 - YPS02-Z.. or YPSC01-Z (for use outside of explosion-risk areas only)
 - YPS02-X.. or YPSC01-X (for use inside explosion-risk areas)
- ⚠ When operating a scale in an explosive area:
 - Follow all current standards and regulations for the installation of devices in the explosive area.
 - Device installation in Zone 1 should be carried out by trained personnel and checked properly.
- ⚠ Connect devices to a central equipotential bonding conductor before operation:

Warm-up Time

To deliver precise results, the scale must warm up for at least 30 minutes after initial connection to the power supply. Only after this time will the scale have reached the required operating temperature.

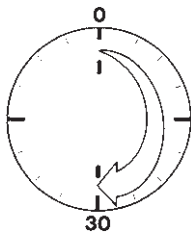

Using a verified scale in legal metrology:

- Make sure to allow the analyzer to warm up for at least 24 hours after initial connection to the power supply.

Leveling the Weighing Platform

Purpose:

- To compensate for unevenness at the place of installation
 - To ensure that the equipment is placed in a perfectly horizontal position for consistently reproducible weighing results
- Always level the weighing platform again any time after it has been moved to a different location.

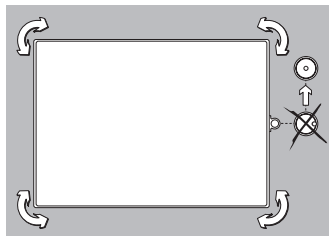

- Level the weighing platform using the four leveling feet. Turn the feet until the air bubble is centered in the level indicator.
- Check to ensure that all leveling feet rest securely on the work surface.
- > Each of the leveling feet must support an equal load.

General View of the Equipment

Signum® 3

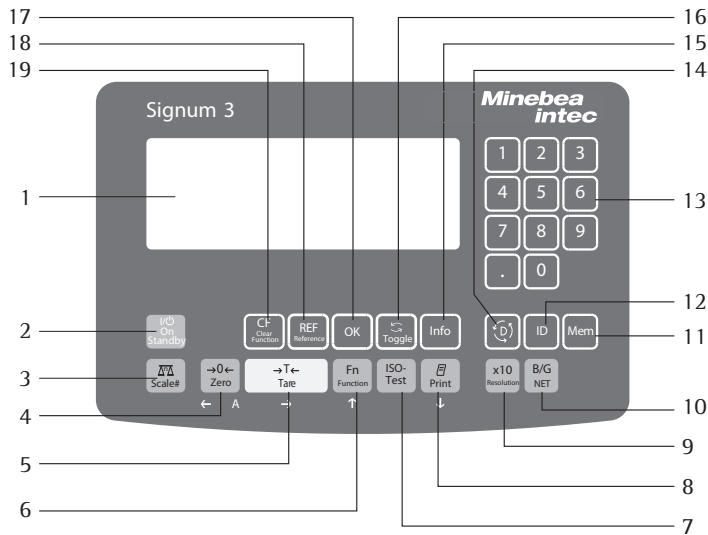

Display and Keypad

- 1 Display
(for details, see the chapter entitled "Operating Concept")
- 2 On/Off key (Standby)
- 3 Keys with no function
- 4 Zero key
- 5 Tare key
- 6 Function key unit conversion
- 7 Start calibration or adjustment
- 8 Print key (data output)
- 9 Toggle unit between normal and 10-fold higher resolution
- 10 View gross value (net value plus tare)
View net value (gross value minus tare)
- 11 Product Data Memory
- 12 ID key for entering the operator ID
- 13 Numerical keypad
- 14 Toggle between application program and application-specific information
- 15 Display of applications and manual tare values
- 16 Toggle key
(function depends on application)
- 17 OK key
(function depends on application)
- 18 Reference value key
(function depends on application)
- 19 Clear function key
(function depends on active application)

BBP

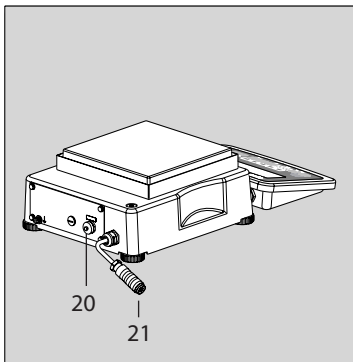

DCP

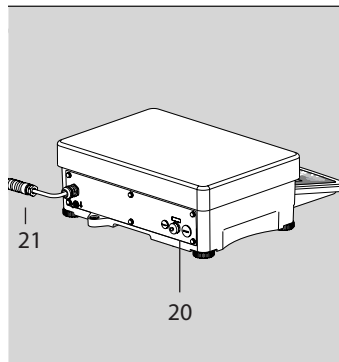

BBS

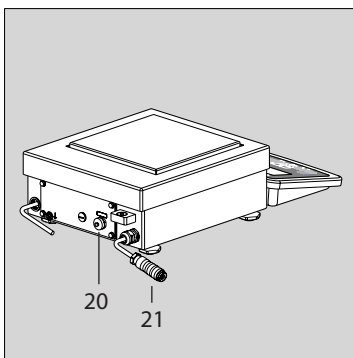

DCS

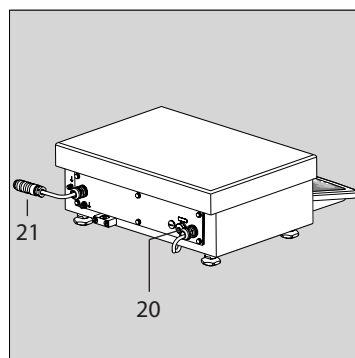

Back Panel

- 20 RS-232C interface "COM1" (standard)
- 21 Power supply connection

Operating Concept

Keypad

Signum® 3 is operated using a minimum of keys. These keys have one function in the measuring mode and another in the menu. Some of the keys have one function when pressed briefly, and another when pressed and held for longer than 2 seconds.

If a key is inactive, this is indicated as follows when it is pressed:

- The message "-----" is displayed for 2 seconds. The display then returns to the previous screen content.

Signum® 3 uses application programs to calculate and display weight values and to mark weighing products.

Configure the display and control unit first, using the operating menu to setup the desired application program (printer settings, etc.). Then you can begin weighing.

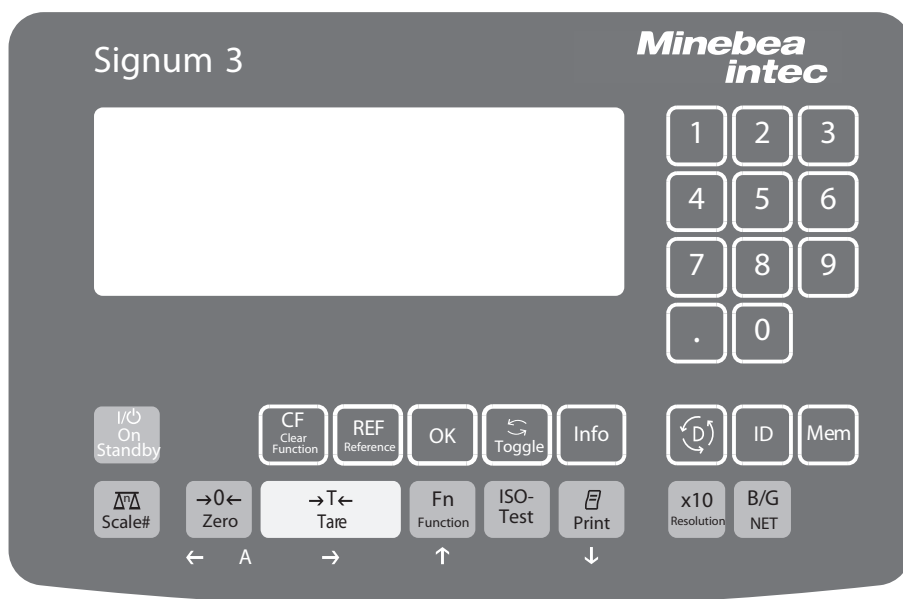

Signum 3 operating panel* .

Input

Keypad Input

Labeled Keys

Some keys have a second function, activated by pressing and holding the key for over 2 seconds. Whether a key function is available depends on the operating state and operating menu settings.

- On/Off (in Standby mode, *STANDBY* is displayed).
- No function
- Zero the scale
- Cancel calibration/adjustment
- Tare the scale:
- Toggles (depending on settings) between the first and second weight unit
- Start calibration or adjustment
- To print: Press the key less than 2 sec.
- Prints GMP footer:
Press longer than 2 seconds.
- Toggles to available application

- ID key (for entering operator ID)
- Toggles unit between normal and 10-fold higher resolution
- Net-gross value key
- Toggles between display modes within an application program
- Lets you modify reference values
- Saves a value or starts an application program
- Saves a value to the product data memory
Press the key less than 2 sec. - Product Data Memory list will be displayed. Enter ID from new product memory beforehand and then press longer than 2 sec. Application values will be saved in the new product ID.

Info Displays applications and manual tare values:

Immediately closes information display: **Info** press and hold longer than 2 seconds. The information is displayed in succession.

CF – Quits an application or deletes an input character

0, **1**, **2**... **9**, **.**
Enters numbers, letters and other characters

Numeric Input Using the Keypad

● Enter numbers (one digit at a time):
Press **0**, **1**, **2**... **9**

● Saving Input:
press the corresponding key.
For example, press **↵T** to save manual tare input.

○ To delete a digit:
Press the **CF** key

Loading a Tare Value from the Weighing Platform

To save the weight on the weighing platform as a tare weight: Press the **↵T** key

Input Through the Digital Control Port

You can connect a remote hand switch or foot switch to the input control line for use with all application programs. Assign one of the following functions to this switch in the Setup menu, under Device parameters - Control input (*CTRL ID*):

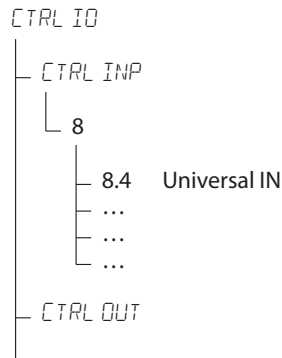

For a detailed list of menu items, please see the chapter entitled "Configuration."

Display Modes

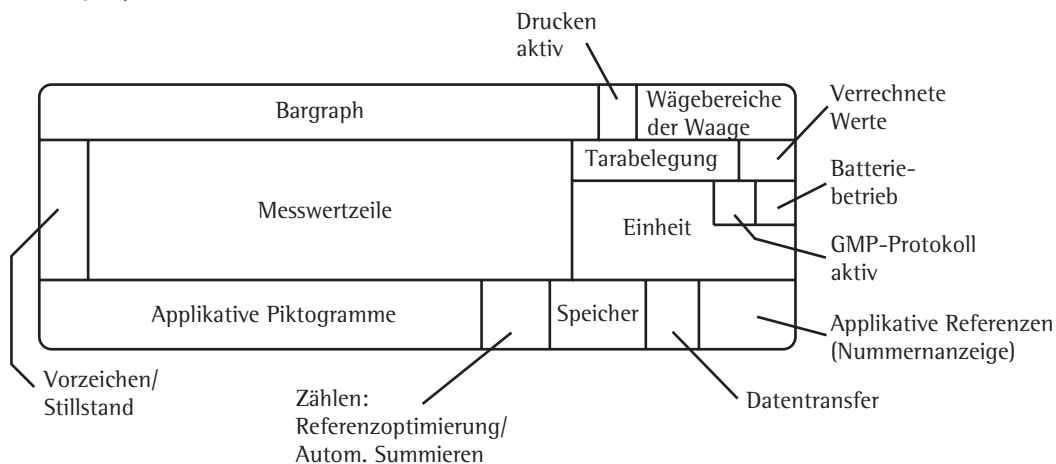

There are two basic display modes:

- Normal operation (weighing mode)
- Unit operating state "Setup" (Configuration).

Weighing Mode: Display of Measured and Calculated Values

Application, Printing and Battery Symbols:

The application symbol indicates the selected program, for example:

- ☼ Counting application
- Ⓞ Printing mode active
- Ⓜ GMP printing mode active

Bar Graph

The bar graph shows the percentage of the weighing platform's capacity that is "used up" by the load on the scale (gross value).

- 0% Lower load limit
- 100% Upper load limit

The following symbols indicate tolerance levels for checkweighing (calculated bar graph):

- Bar graph showing 10% intervals
- Minimum for "checkweighing"
- Target value for "checkweighing"
- Maximum for "checkweighing"

Plus or Minus Sign

- + or - for weight value or calculated value,
- 0← when the weighing platform is zeroed or tared (verified models only)

Line for Weight Values

This field shows weight values, calculated values and input characters.

Unit and Stability:

When the weighing system reaches stability, the weight unit or calculation unit is displayed here.

Tare in Memory, Calculated Values

Meaning of Symbols:

- Calculated value (not valid in legal-for-trade applications)
- NET Net value (gross value minus tare)
- B/G Gross value (net value plus tare)

Data in Tare Memory, Calculated Values, Designation of the Active Weighing Platform

PT Indicates manual taring for tare information

WP 1 Display of the active weighing platform when 2 platforms are connected. The symbol flashes to prompt adjustment of the weighing platform, if the isoCAL function is active.

Application Symbols

For input and display of detailed information; e.g., for the selected application.

- ☼ Counting / Neutral measurement
- % Weighing in Percent
- Ⓞ Averaging (animal weighing)
- ± Checkweighing
- Ⓜ Classification
- Ⓜ Checkweighing toward zero
- Σ Totalizing
- ↓ Net total

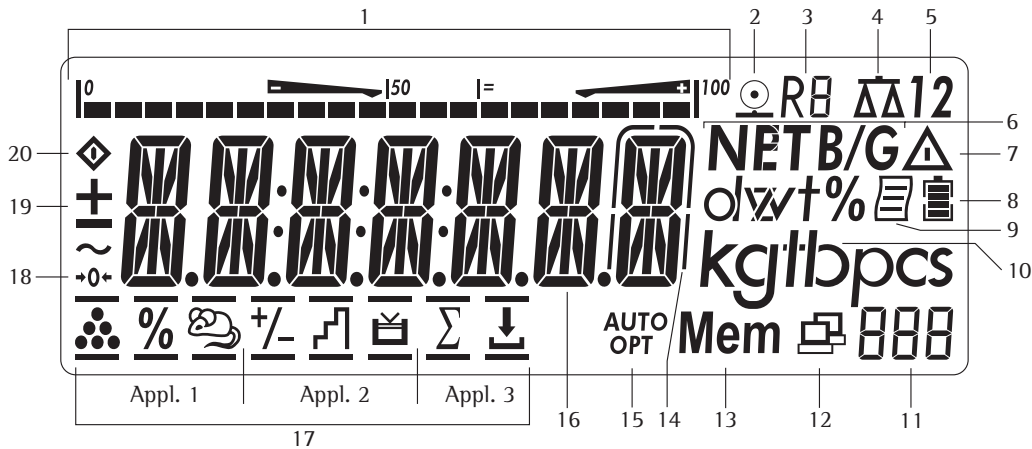

Display in Weighing Mode
The illustration above depicts all of the main display elements and symbols that can be shown during weighing.

1. Bar graph
 - Shows the percentage of the weighing platform's capacity that is "used up" by the load on the scale (gross value), or
 - Shows the weight value in relation to a target value (with the Checkweighing or Classification application)
2. Symbol for current print job
3. Displays the active range on multiple-range scales
4. No second weighing platform possible
5. Weighing platform 1 only
6. Net/Gross value on the main display (with tare in memory or preset tare)
7. Identifies the value on the main display as calculated (value not valid in legal metrology)
8. Charge level indication of rechargeable battery not active (Rechargeable battery not integrated)
9. GMP-compliant printing in progress
10. Weight unit of the value displayed

11. Numeric display; e.g., showing reference value
12. Symbol indicating data transfer
 - Interface initialized
 - Flashes during data transfer
13. Product Data Memory symbol
14. In legal metrology, on equipment with $e \neq d$, the digit shown with a border must not be taken into account
15. Auto/Opt
 - Auto: Depending on the weight value, a reaction is triggered in the application
 - Opt: Automatic optimization has taken place for the Counting application
16. Weight value or calculated value (main display)
17. Application symbols for the applications:

Application 1:

- ☼ Counting / Neutral measurement
- % Weighing in Percent
- 🐾 Averaging (animal weighing)
- ±/- Application 2: Checkweighing
- 📈 Classification
- 📦 Checkweighing toward zero; Manually batching toward zero

Application 3:

- ∑ Totalizing
- ⬇️ Net total

Verified models only:

18. The zero-setting symbol is displayed after the active scale or weighing platform has been zeroed
19. Plus or minus sign of the value displayed
20. Busy symbol indicates that an internal process is in progress

Saving Data in Weighing Mode

- All of the application parameters saved (e.g., reference values) remain in memory and are still available after
- Signum® has been switched off and on
 - you return to the originally selected application from a second one (e.g., when you switch from Averaging back to Counting, all parameters saved for Counting are available)

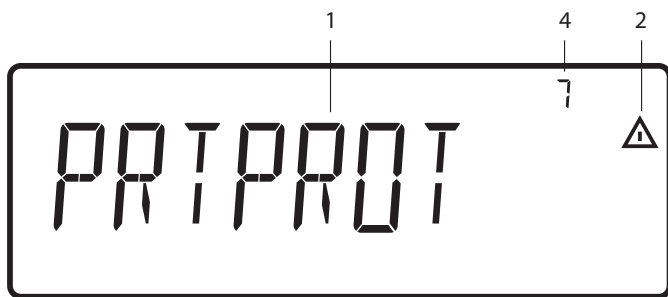

Setup Menu Display: Text Menu (Example)

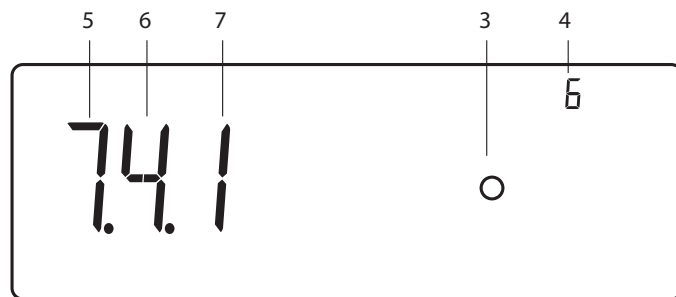

Setup Menu Display: Numeric operating menu (example)

Menu Operating Concept

The keys below the display are used to navigate and make entries in the device menu.

Opening the Menu

Press the key to switch the device off and then on again; while all segments are displayed, press the key briefly.

Navigating the Menu

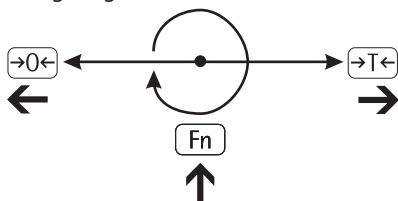

Exit the active submenu and return to the next higher menu level (back).

– Press briefly:
Select and save a menu item.
– Press longer than 2 seconds:
exit the menu.

Show the next item on the same menu level (the display scrolls through all items in series).

Print the menu settings starting from the current position, or print Info data.

Alphanumeric Input in the Menu

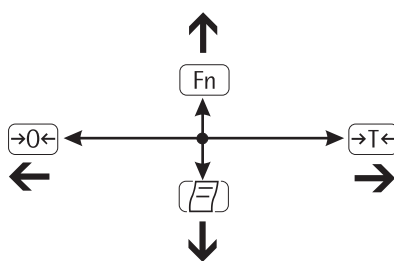

– Press briefly:
Activate character to the left of the currently active character (when first character is active: exit the input mode without saving changes)
– Press longer than 2 seconds: Exit the input mode without saving changes

– Press briefly:
Confirm currently active character and move 1 position to the right (after the last character: save input)
– Press longer than 2 seconds:
Save current input and display the menu item

– Cursor in first position, no characters entered yet:
Delete character(s) and enter 0
– Change the displayed character; scroll backwards (sequence: 0 ... 9, decimal point, minus sign, Z _ A, space)

– Cursor in first position, no characters entered yet: Delete character(s) and enter a space
– Change the displayed character; scroll backwards (sequence: space, A _ Z, minus sign, decimal point, 9 _ 0)

Numeric input in the Signum operating menu®
Enter values (date and time, etc.) using the 10-key numeric keypad

Menu Display

The illustration above depicts all of the main display elements and symbols that can be shown in the Setup menu.

- 1 Selected menu item at text level (e.g. printer for setting the connected printer)
- 2 Note that other submenus are available
- 3 Currently active setting
- 4 Menu history (note at highest menu level in the Setup menu)
- 5 First level in the Setup menu
- 6 Second level in the Setup menu
- 7 Third level in the Setup menu

Saving Menu Settings

The parameters selected in the operating menu remain saved after you switch off the Signum®. You can block access to Setup in the device menu by assigning a password. This will prevent unauthorized changes to selected menu parameters.

Error Messages

- If a key is inactive, "-----" and/or "No function" is displayed briefly (2 sec.)
- Temporary errors are displayed for 2 seconds in the weight value/result line via an error code (e.g., Inf 09); fatal errors (e.g., Err 101) are displayed continuously until "Reset" is used.

Error codes are described in detail under "Error Codes".

Data Output

Printer

You can connect a strip or label printer to Signum[®] 3. You can have printouts output at the press of a key or automatically. Printout formats are user-definable. You can also configure separate summarized printouts, and print a list of the active menu settings. See section "Configuring Printouts".

Digital Input/Output Interface + Optional I/O

The digital input/output interface is supported by the "Checkweighing" and "Classification" application programs.

Checkweighing

The output device has a number of control functions. Four data outputs transfer signals for "less than," "equal to," "greater" and "set." You can define whether the outputs are always active or are activated only at stability, only within the checkweighing range, only within the checkweighing range at stability, or switched off.

Classification

Four data outputs transfer information on the class of the load (Class 1, 2, 3, 4 or 5) and indicate when the minimum load is exceeded (Set).

You can define whether the outputs are always active, activated only at stability, or off. See "Application: Classification" in the enclosed "Basic Application Programs" manual for details.

Communication Interface

You can define a number of parameters for this SBI interface (print command, time-dependent autoprnt, ID codes). See section "Data Interface".

Saving Data

Signum[®] 3 saves all application parameters (e.g. reference values) when the device is turned off or you switch between application programs. You can assign a password to prevent unauthorized users from changing settings in the "Device parameters" menu under:

```

SETUP
└── U-CODE
    
```

see "Configuration"

Configuration

You can configure the device by selecting parameters in the Setup menu. These are divided into the following groups (first menu level):

- Application parameters
- Fn key function
- Device parameters
- Device-specific information "INFO"
- Language

When used in legal metrology, not all parameters can be accessed.

Factory-set parameters are identified by an "*" in the operating menu list.

You can choose from five languages for the display of information:

- German
- English (factory setting)
- English with U.S. date/time
- French
- Italian
- Spanish

Printing parameter settings:

- Press the **[E]** key in Setup

Scope of printout:

Depends on the position in Setup

Language Settings

Example: Selecting "US Mode" for the language

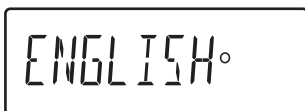
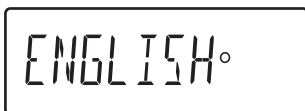
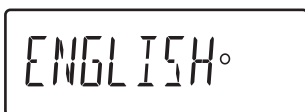
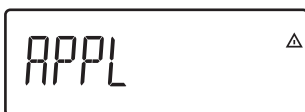
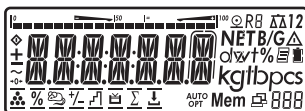

Press and hold to exit the menu

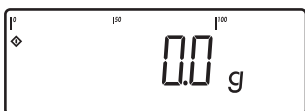

Turn on the device

While all segments are lit, press the **[→T←]** key

The first item in the main menu is shown
APPL

Switch to the *LANG* menu item (press **[Fn]** repeatedly until *LANG* is shown)

Select *LANG* to open the submenu for setting the language

The currently active language is shown

Switch to the *US MODE* menu item (press **[Fn]** repeatedly until *US MODE* is displayed)



Save the menu item

Exit this menu level and configure other settings as desired, or



Protecting Setup With a User Password

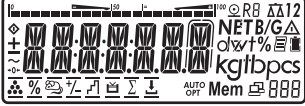

Example: Assign a password to protect the application program settings APPL and the device parameters SETUP from unauthorized changes (in this example, AB2)



-  1.) Switch on Signum®



-  2.) While all segments are lit, press the  key





The first item in the main menu is shown: *APPL*



-  3.) Select the *SETUP* menu item (press the  key repeatedly until *SETUP* is displayed)





-  4.) Select the *SETUP* device parameter



-  5.) Select the *CODE* menu item (press  repeatedly until *U-CODE* is displayed)





-  6.) Select the menu item user password



-  7.) Enter the first character using the  and  keys (in this example: *A*)





-  8.) Save the character

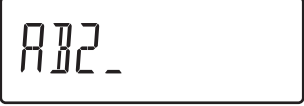

-  9.) Enter the second character using the  and  keys (in this example: *B*)



-  10.) Save the character

-  11.) Enter the third character using the  and  keys (in this example: *2*)

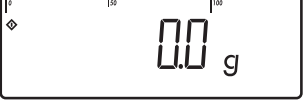
-  12.) Confirm the password

-  13.) Exit this menu level and configure other settings as desired, or
-  14.) Exit menu, press and hold the  key



To delete a password: Overwrite the old password with the new password, or enter a space as the password and press the  key to confirm

Operating Menu Overview

In the Setup menu, you can configure the display and control unit to meet your individual requirements. User data can be entered and pre-set parameters selected.

Menu levels are identified by texts, and numeric codes identify the individual settings.

1st Level Display	2nd Level Display	Meaning
Menu		
APPL		Select and configure application programs
	Δ /WEIGH.	Basic weighing function
	$\bullet\bullet\bullet$ /COUNT.	Counting application
	$\bullet\bullet\bullet$ NM/NEUTR.M	Neutral measurement
	🐷 /ANIM.WG	Averaging (animal weighing)
	⚖ /CHECK.WG	Checkweighing
	📊 /CLASS.	Classification:
	$\%$ /PERC.WG	Weighing in percent
	\downarrow /NET TOT	Net-total formulation
	Σ /TOTALIZ	Totalizing
FN-KEY		Define the function of the Fn key
	OFF	No function
	2.UNIT	Display 2nd Unit
	SQMIN	Display the minimum permissible sample quantity ¹⁾
SETUP		Customizing Signum® to user requirements
	WP-1	
	COM1	Settings for the RS232, RS485, RS422 interfaces
	CTRL IN	Function setting for universal input (control line)
	PRTPROT	Printout settings
	UTILIT	Additional function settings
	TIME	Time settings
	DATE	Date settings
	U-CODE	User password to protect settings
	SQMIN	User: <ul style="list-style-type: none"> - Display - Include SQmin in GMP printout
	CLR.LEG.S	Clear alibi memory (only in service mode)
	LEG.S.PER	Alibi memory retention period
INFO		Display device-specific information (service date, serial number, etc.)
LANG		Language selection for calibration, adjustment and GMP printouts
	DEUTSCH	German
	ENGLISH	English
	US MODE	English with U.S. date time
	FRANC	French
	ITAL	Italian
	ESPAÑOL	Spanish

¹⁾ Only active when minimum sample quantity has been entered by Service and menu item: SQMIN: DISPLAY: ON

Operating Menu

* Factory setting

Menu

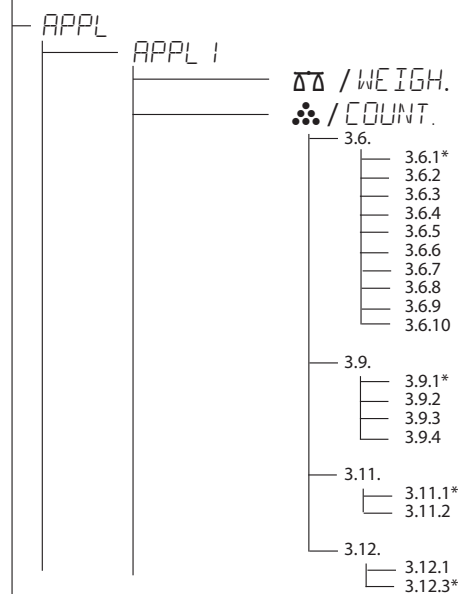

Application programs

Basic Weighing Function

Counting
 Minimum load for initialization
 1 digit
 2 digits
 5 digits
 10 digits
 20 digits
 50 digits
 100 digits
 200 digits
 500 digits
 1000 digits

Resolution for calculation of reference value
 Display accuracy
 Display accuracy + 1 decimal place
 Display accuracy + 2 decimal places
 Internal resolution

Parameter for saving weight values
 With stability
 With increased stability

Average piece weight updating
 Off
 Automatic

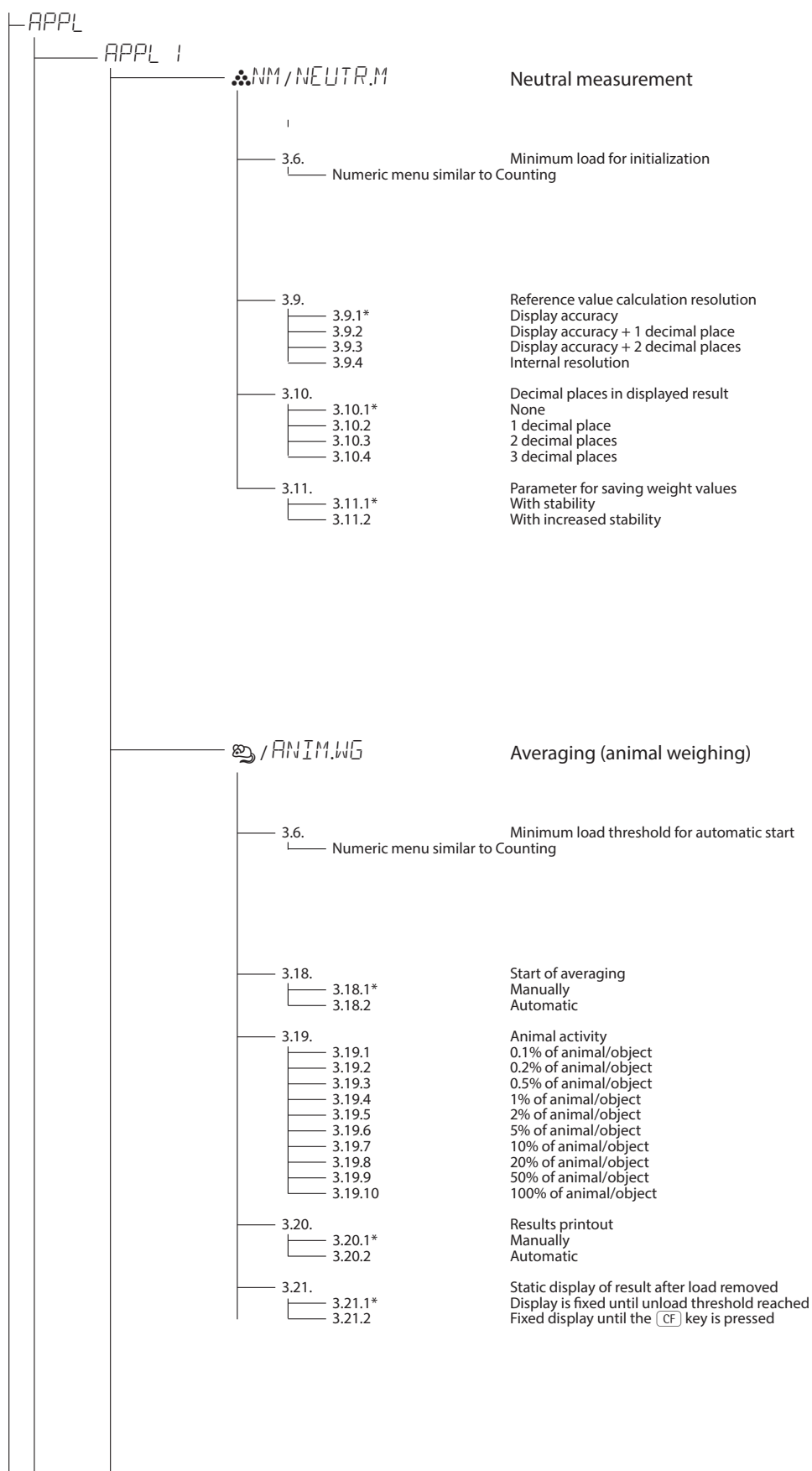

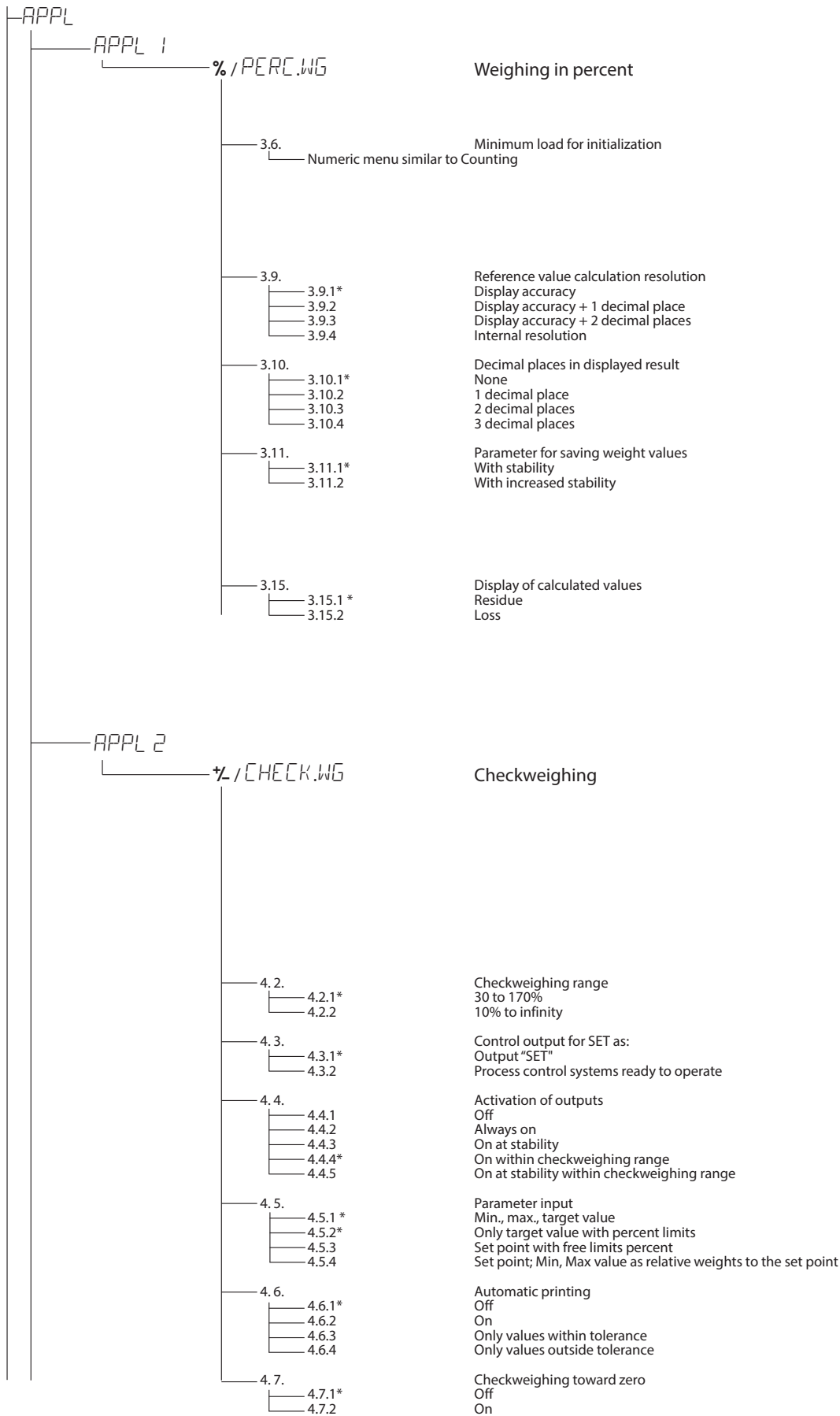

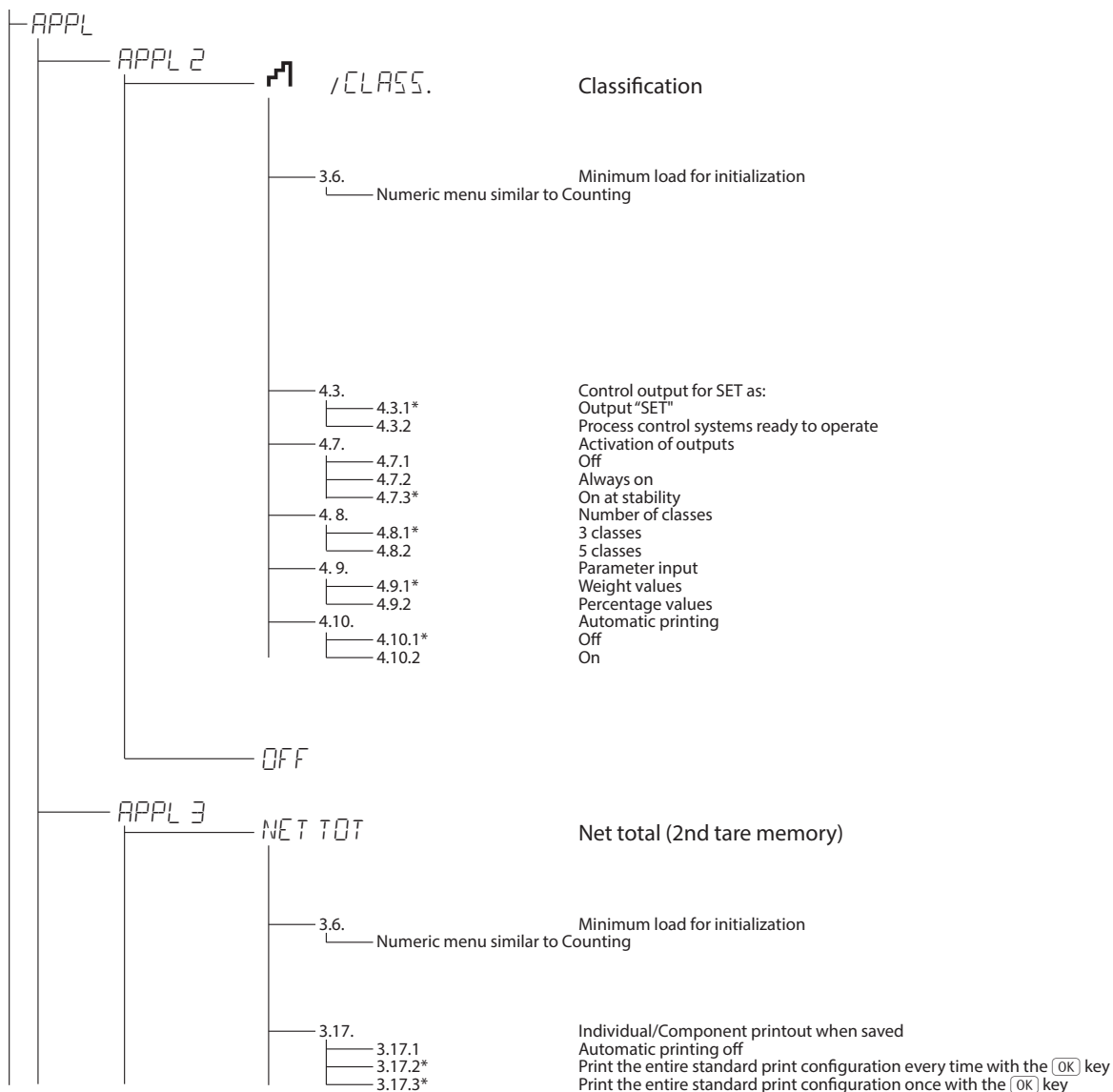

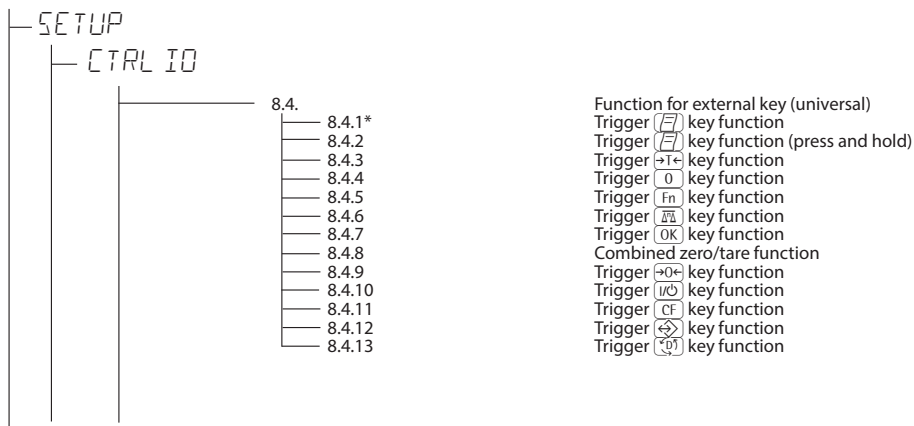
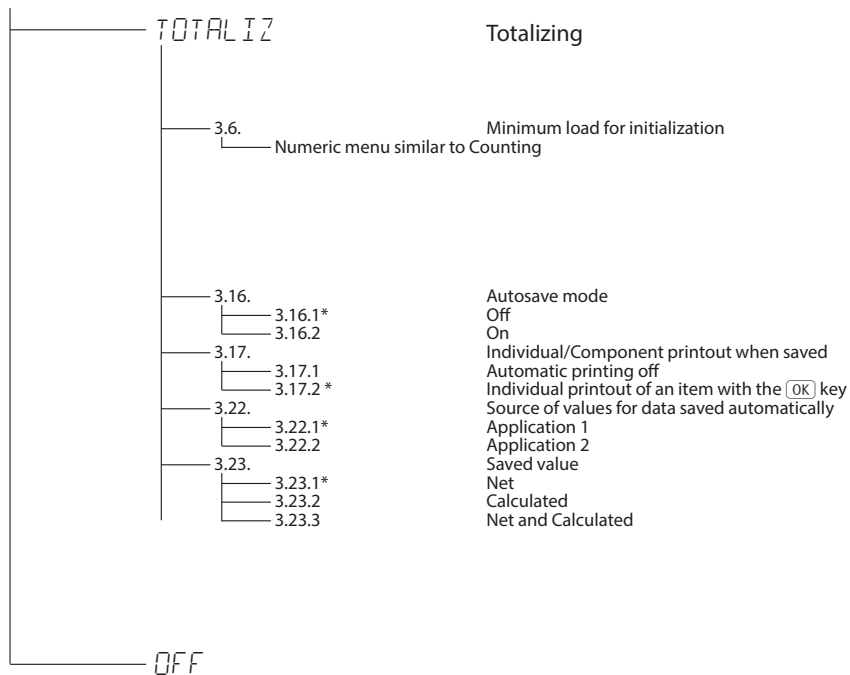

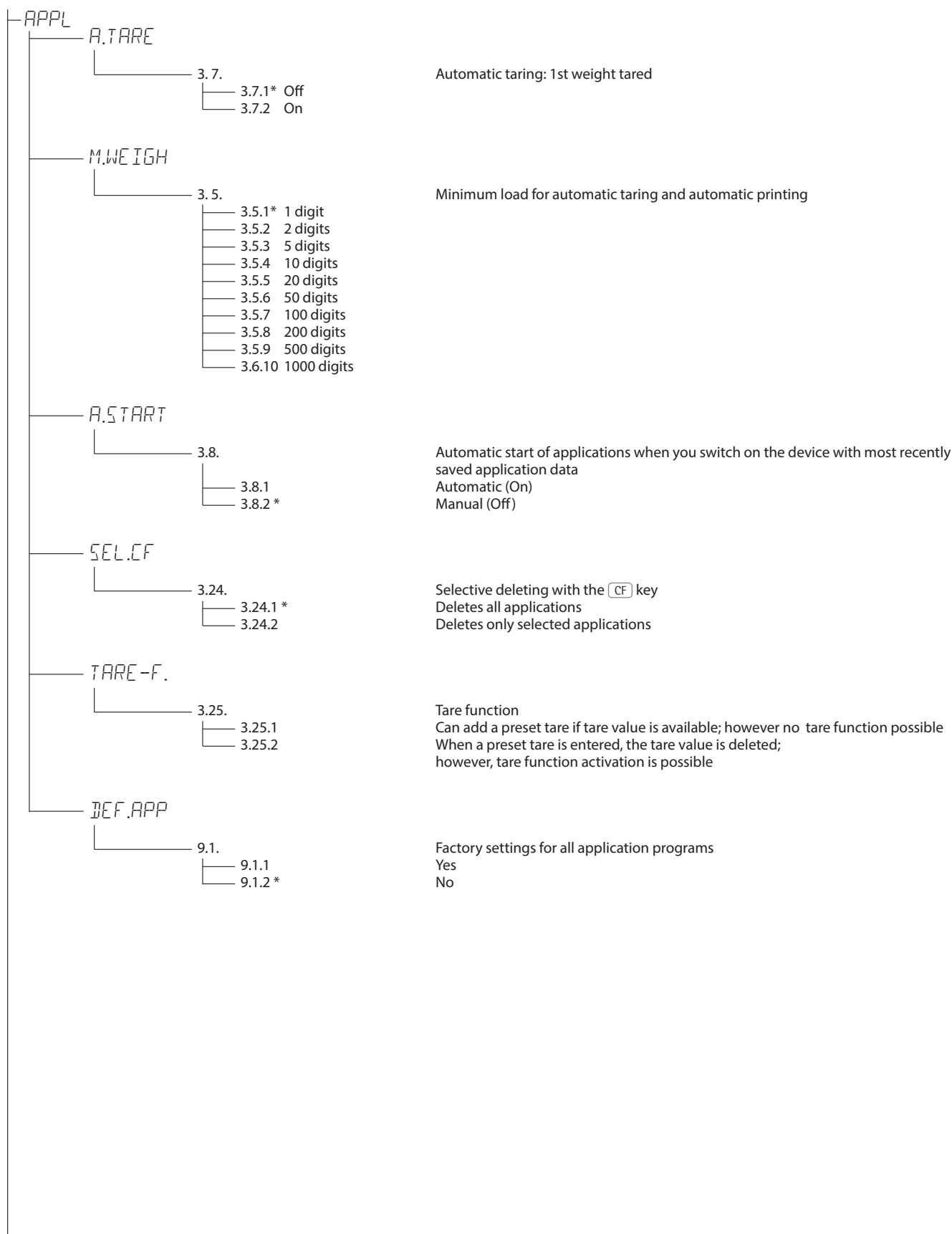

FN-KEY		
—	OFF *	
—	2ND UNIT	Key assignment Fn
—	SQMIN	Fn key
SETUP		Display the 2nd unit
WP-1 ¹		Display the minimum permissible sample quantity ³⁾
—	1.1.	Device Parameters
—	1.1.1	A password prompt is displayed if a password is configured
—	1.1.2 *	Weighing platform 1
—	1.1.3	(Display designation of this menu level: i)
—	1.1.4	Adapting the scale to ambient conditions (filter adjustment)
—	1.2.	Very stable
—	1.2.1 *	Stable
—	1.2.2	Unstable
—	1.2.3	Very unstable
—	1.2.4	Application filter
—	1.3.	Final readout
—	1.3.1	Filling mode
—	1.3.2 ⁴⁾	Low filtering
—	1.3.3	Without filtering
—	1.3.4 *	Stability range
—	1.3.5	¼ digit
—	1.3.6	½ digit
—	1.4.	1 digit ¹⁾
—	1.4.1	2 digits ¹⁾
—	1.4.2	4 digits ¹⁾
—	1.4.3	8 digits ¹⁾
—	1.4.4	Stability delay
—	1.5.	Without delay
—	1.5.1	Short delay
—	1.5.2 *	Average delay
—	1.6.	Long delay
—	1.6.1	Taring ¹⁾
—	1.6.2	Without stability
—	1.7.	After stability
—	1.7.1	Autozero
—	1.7.2 *	On
—	1.7.3	Off
—	1.7.4	Weight unit 1 ²⁾
—	1.7.5	Gram / o ¹⁾
—	1.7.6	Gram /g
—	1.7.7	Kilogram /kg
—	1.7.8	Carat /ct ¹⁾
—	1.7.9	Pound /lb ¹⁾
—	1.7.10	Ounces /oz ¹⁾
—	1.7.11	Troy ounces /ozt ¹⁾
—	1.7.12	Tael Hongkong /tlh ¹⁾
—	1.7.13	Tael Singapur /tls ¹⁾
—	1.7.14	Tael Taiwan /tlt ¹⁾
—	1.7.15	Grain /GN ¹⁾
—	1.7.16	Pennyweight /dwt ¹⁾
—	1.7.17	Parts per Pound //lb ¹⁾
—	1.7.18	Tael China /tlc ¹⁾
—	1.7.19	Momme /mom ¹⁾
—	1.7.20	Austrian carats /K ¹⁾
—	1.7.21	Tola /tol ¹⁾
—	1.7.22	Baht /bat ¹⁾
—	1.8.	Mesghal /MS ¹⁾
—	1.8.1 *	Tons /t ¹⁾
—	1.8.2	Pound: Ounces ¹⁾
—	1.8.14	Display accuracy ¹⁾
—	1.8.15	All digits
—	1.8.16	Reduced by 1 decimal place for load change
		10-fold increased resolution
		Increase resolution by 2 scale intervals
		Increase resolution by 1 scale interval

1) = Not available on equipment verified for use in legal metrology

3) = Only active when minimum sample quantity has been entered by Service and menu item: SQMIN:DISPLAY:ON

4) = Factory setting for use in legal metrology

<p>— SETUP</p> <p>— WP-11</p> <ul style="list-style-type: none"> — 1.9. <ul style="list-style-type: none"> — 1.9.1 * — 1.9.3 — 1.9.4 — 1.9.8 — 1.9.9 — 1.9.10 — 1.10. <ul style="list-style-type: none"> — 1.10.1 — 1.10.2 * — 1.11. <ul style="list-style-type: none"> — 1.11.1 — 1.11.2 * — 1.12. <ul style="list-style-type: none"> — 1.12.1 * — 1.12.2 — 1.12.3 * — 1.13. <ul style="list-style-type: none"> — 1.13.1 * — 1.13.2 — 1.13.3 — 1.15. <ul style="list-style-type: none"> — 1.15.1* Off — 1.15.2 — 1.16. <ul style="list-style-type: none"> — 1.16.1 * — 1.16.2²⁾ — 1.17. <ul style="list-style-type: none"> — 1.17.1 * — 1.17.2 — 1.17.4¹⁾ — 1.18. <ul style="list-style-type: none"> — 1.18.1 — 3.1. <ul style="list-style-type: none"> — 3.1.1 — 3.1.2 — 3.1.3 * — 3.1.4 — 3.1.5 — 3.1.6 — 3.1.7 — 3.1.8 — 3.1.9 — 3.1.10 — 3.1.11 — 3.1.12 — 3.1.14 — 3.1.15 — 3.1.16 — 3.1.17 — 3.1.18 — 3.1.19 — 3.1.20 — 3.1.21 — 3.1.22 — 3.2. <ul style="list-style-type: none"> — 3.2.1 * — 3.2.2 — 3.2.14 — 3.2.15 — 3.2.16 — 3.3. — 3.4. — 9.1. <ul style="list-style-type: none"> — 9.1.1 — 9.1.2 * 	<p>Calibration and Adjustment</p> <p>Ext. calibration/adjustment; default weight</p> <p>External calibration/adjustment; weight can be selected under menu item 1.18.1</p> <p>Internal adjustment (models with built-in motorized calibration weight only)</p> <p>Set preload</p> <p>Clear preload</p> <p> key locked</p> <p>Calibration/Adjustment sequence</p> <p>Calibration with automatic adjustment</p> <p>Cal. then manually adjust</p> <p>Zeroing range</p> <p>1 percent/max. cap.</p> <p>2 percent/max. cap.</p> <p>Initial zero point range</p> <p>Factory setting (depending on the model type)</p> <p>2 percent/max. cap.</p> <p>5 percent/max. cap.</p> <p>Tare/zero at power on:</p> <p>On</p> <p>Off, load previous tare values</p> <p>Only zero at power on</p> <p>Adjustment prompt for connected IS weighing platform</p> <p>Adjustment prompt $\Delta\bar{\Delta}$ flashes on the display</p> <p>External adjustment¹⁾</p> <p>Activated</p> <p>Blocked</p> <p>Calibration weight unit³⁾</p> <p>Gram</p> <p>Kilogram</p> <p>Pound</p> <p>Entering adjustment weight</p> <p>External user adjustment weight (enter value, e.g.: 10,000 kg)</p> <p>Weight unit^{2 3)}</p> <p>Gram / o¹⁾</p> <p>Gram /g</p> <p>Kilogram /kg</p> <p>Carat /ct¹⁾</p> <p>Pound /lb¹⁾</p> <p>Ounces /oz¹⁾</p> <p>Troy ounces /ozt¹⁾</p> <p>Tael Hongkong /tlh¹⁾</p> <p>Tael Singapur /tls¹⁾</p> <p>Tael Taiwan /tlt¹⁾</p> <p>Grain /GN¹⁾</p> <p>Pennyweight /dwt¹⁾</p> <p>Parts per Pound //lb¹⁾</p> <p>Tael China /tlc¹⁾</p> <p>Momme /mom¹⁾</p> <p>Austrian carats /K¹⁾</p> <p>Tola /tol¹⁾</p> <p>Baht /bat¹⁾</p> <p>Mesghal /MS¹⁾</p> <p>Tons /t¹⁾</p> <p>Pound: Ounces¹⁾</p> <p>Display accuracy²⁾</p> <p>All digits</p> <p>Reduced by 1 decimal place for load change</p> <p>10-fold increased resolution</p> <p>Increase resolution by 2 scale intervals</p> <p>Increase resolution by 1 scale interval</p> <p>Weight unit³⁾: Parameters, see 3.1 "Weight unit 2"</p> <p>Display accuracy³⁾: Parameters, see 3.2 "Display accuracy 2"</p> <p>Restore factory settings in WP1 numeric menu</p> <p>Yes</p> <p>No</p>
---	---

¹⁾ = Not available on instruments verified for use in legal metrology ²⁾ = Factory setting on instrument verified for use in legal metrology ³⁾ = Menu depends on weighing platform model

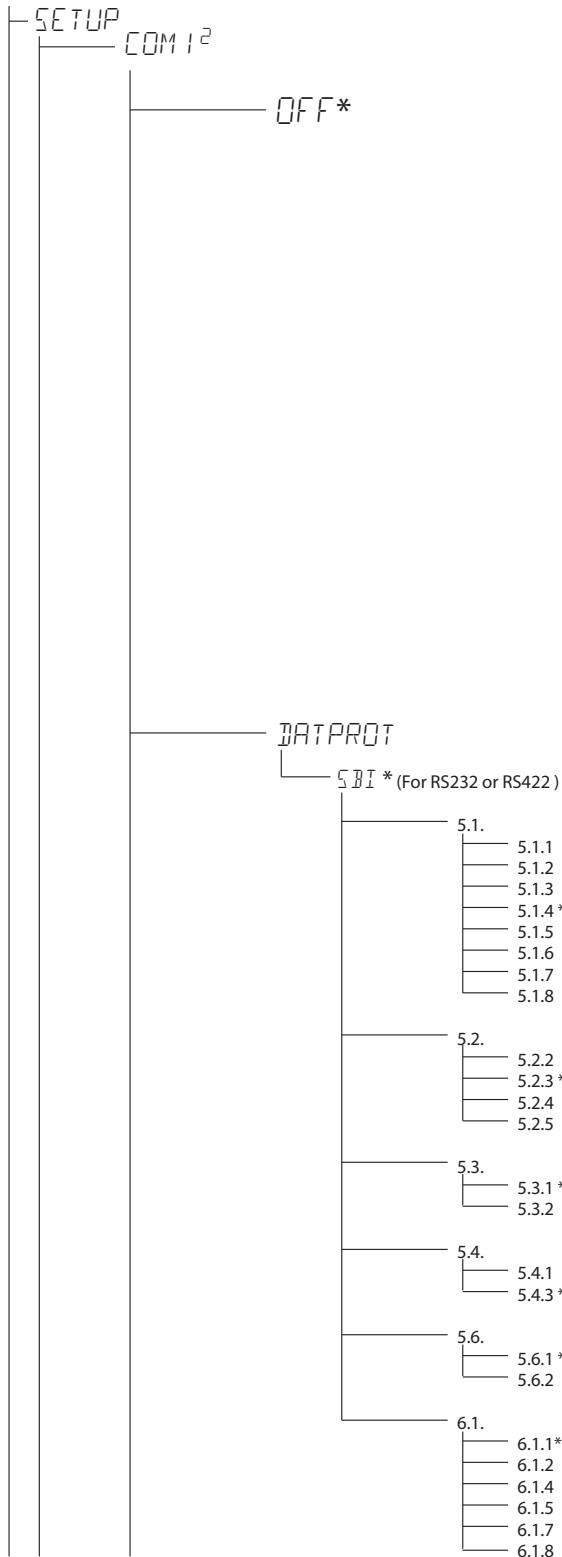

Interface 1

(Display designation of this menu level: 2)

Off

Data printout

SBI standard version

Baud rate

- 150 Baud
- 300 Baud
- 600 Baud
- 1200 Baud
- 2400 Baud
- 4800 Baud
- 9600 Baud
- 19200 Baud

Parity

- Space ²⁾
- Odd
- Even
- None ³⁾

Number of stop bits

- 1 stop bit
- 2 stop bits

Handshake mode

- Software handshake
- Hardware handshake, 1 character after CTS

Number of data bits

- 7 data bits
- 8 data bits

Data output (manual/automatic)

- Manual without stability
- Manual after stability
- Automatic output without stability
- Automatic with stability
- Protocol printout for computer (PC)
- Protocol printout without stability for computer (PC)

* Factory setting

¹⁾ = Menu depends on weighing platform

²⁾ = Not with setting 5. 6. 2 (8 bit)

³⁾ = Not with setting 5. 6. 1 (7 bit)

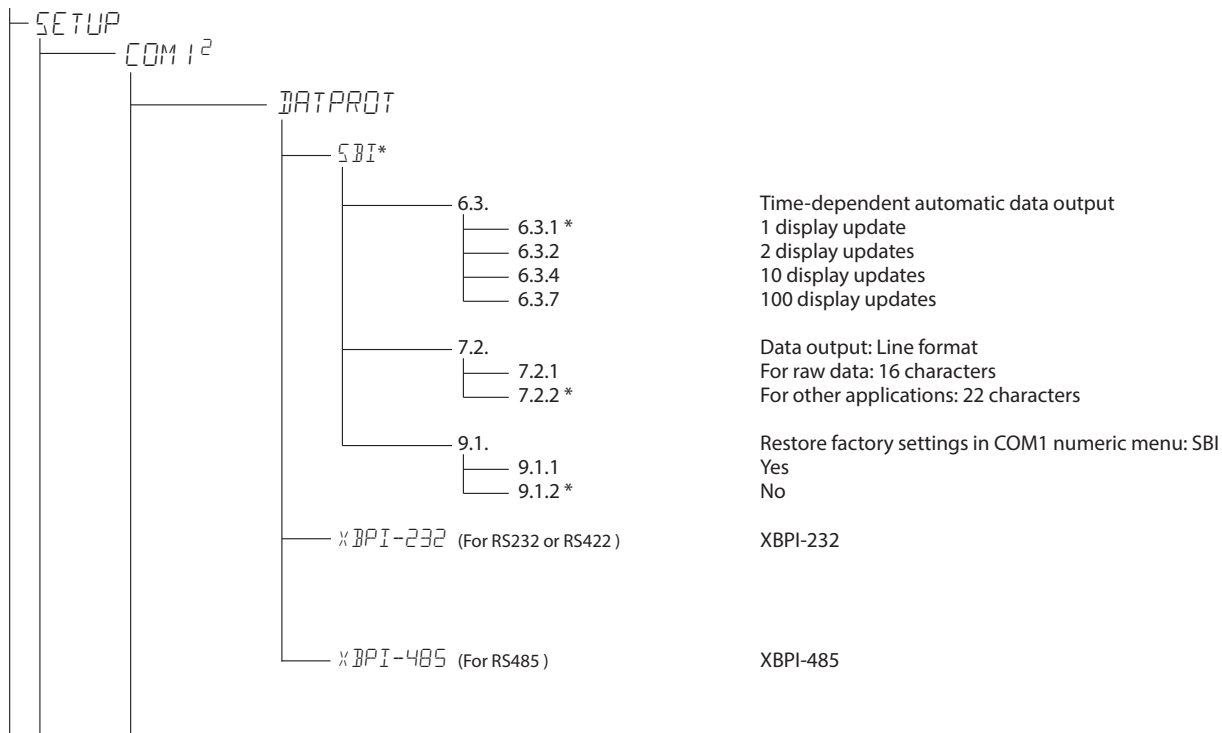

* Factory setting

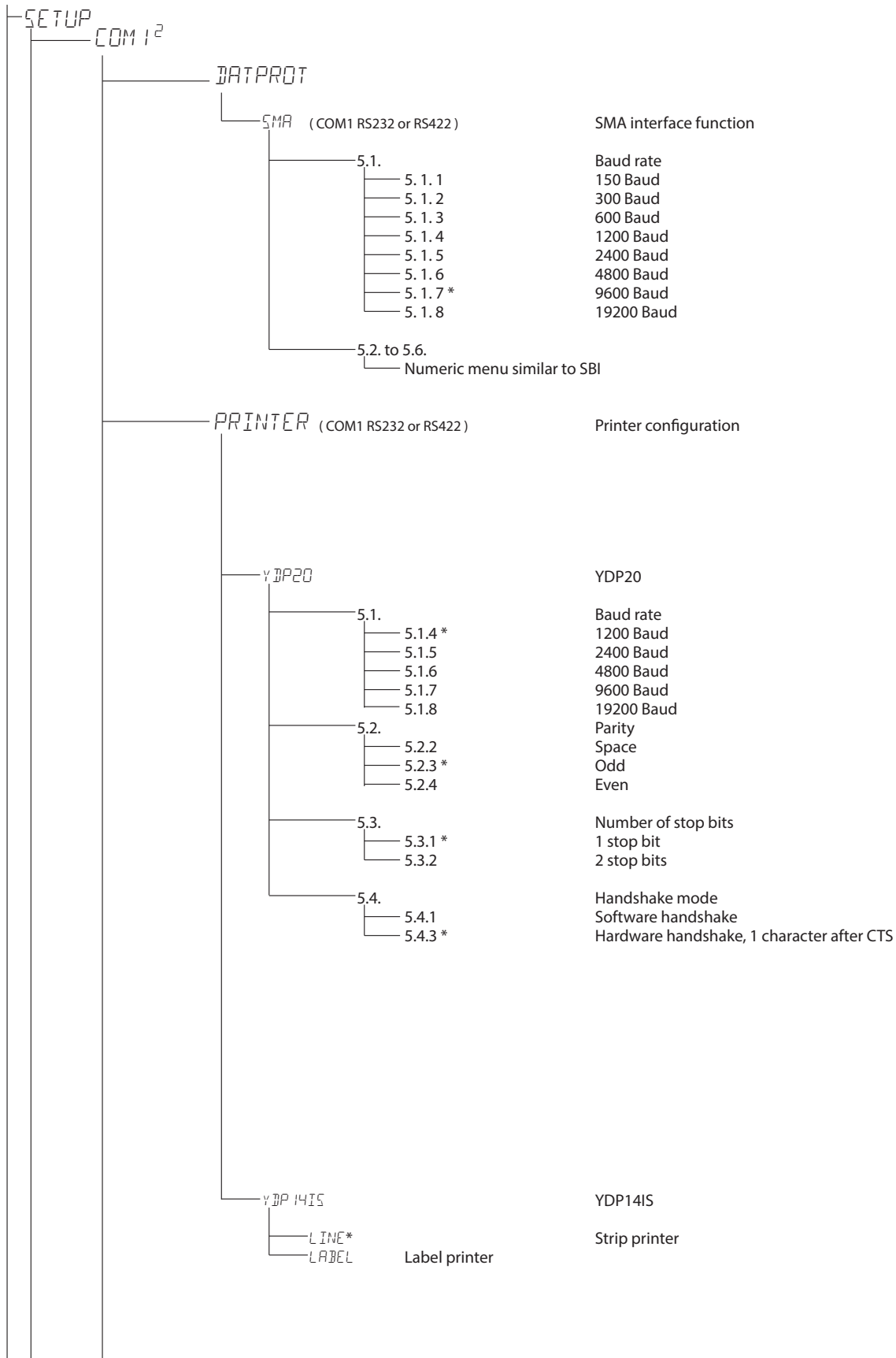

* Factory setting

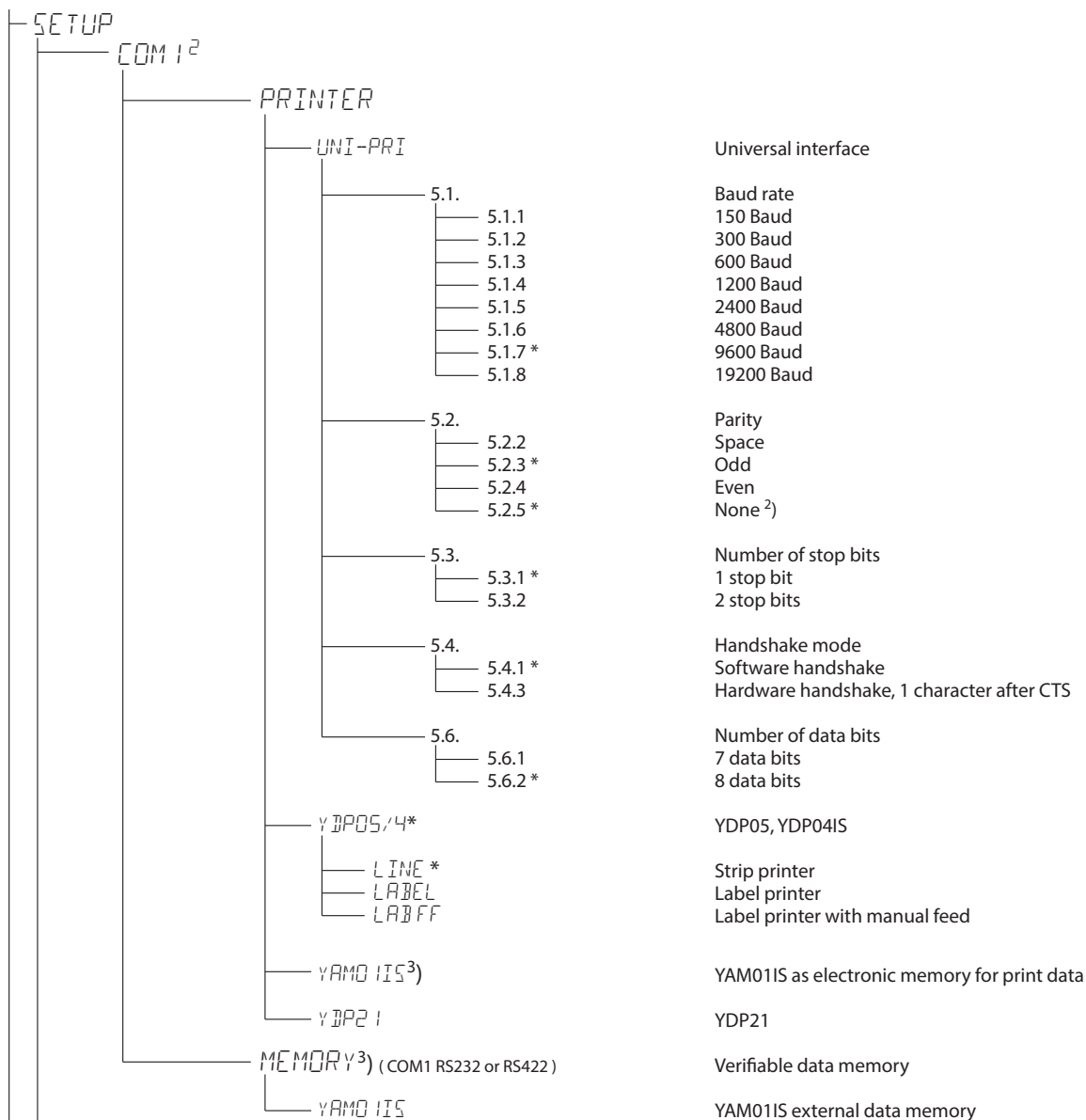

* Factory setting
 1) = Not with setting 5. 6. 2 (8 bit)
 2) = Not with setting 5. 6. 1 (7 bit)
 3) = Only if no alibi memory is active

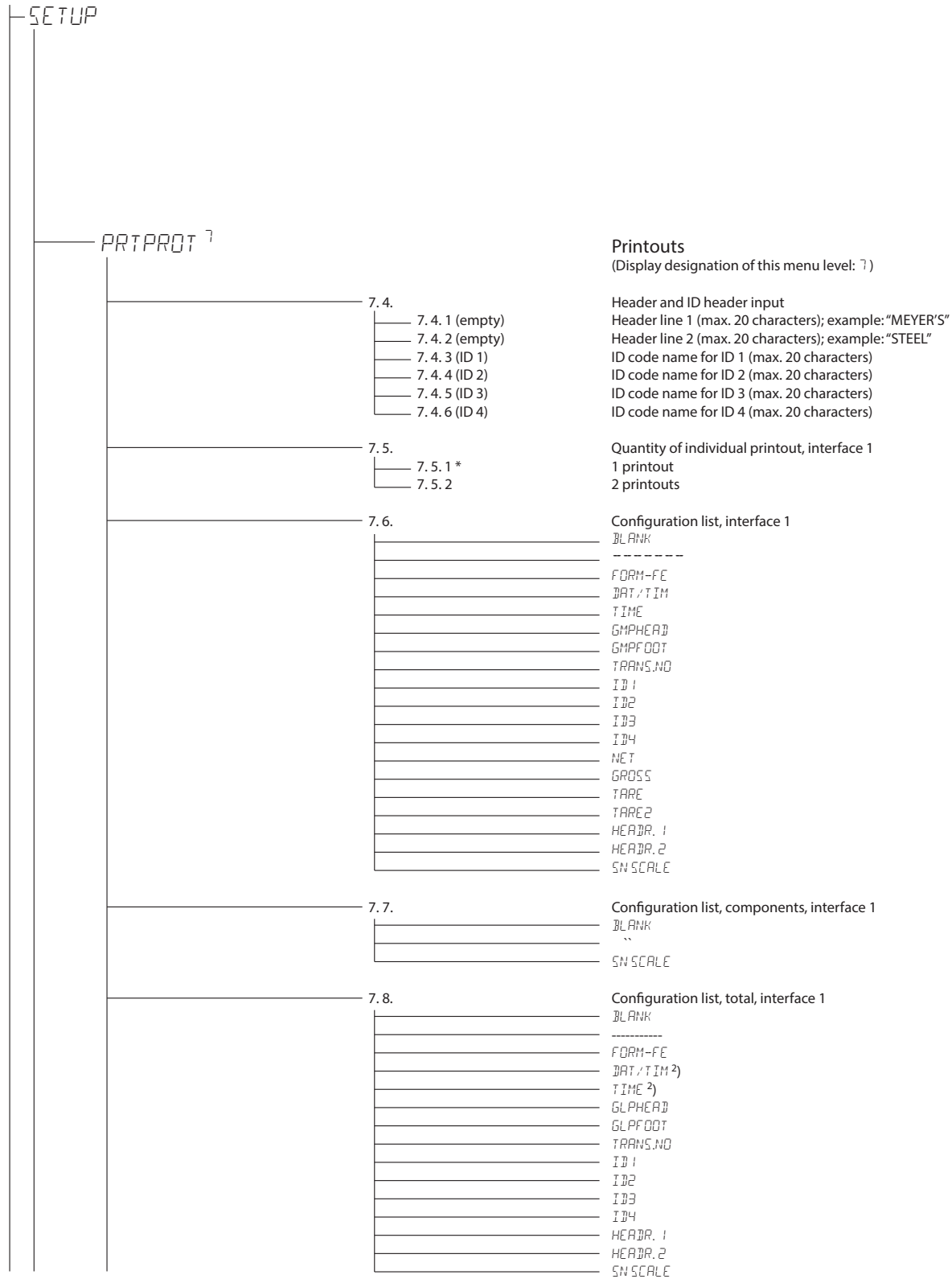

* Factory setting

SETUP			
PRTPROT 7			
	7.13.		GMP-compliant printouts
	7.13.1*		Off
	7.13.3		On
	7.14.		Date/Time
	7.14.1 *		Date/Time block with time
	7.14.2 *		Date/Time block without time
	7.15.		Automatic printing at stability
	7.15.1 *		One-time auto print at stability off
	7.15.2		One-time auto print at stability on
	7.16.		Flex print
	7.16.1*		OFF
	7.16.2		ON
	7.17.		Decimal separator
	7.17.1 *		Period
	7.17.2		Comma
	7.18.		Printout of Alibi and product data memory
	7.18.1.1 *		Select all data records
	7.18.1.2		Print the number of data records selected under 7.18.2
	7.18.2		Select quantity: 1* to 255
	9.1.		Restore factory settings in numeric menu for printout data protocol
	9.1.1		Yes
	9.1.2 *		No

* Factory setting

<p>SETUP</p> <p>UTILIT ^B</p> <p>8.3.</p> <p>8.3.1 *</p> <p>8.3.2</p> <p>8.3.3</p> <p>8.3.4</p> <p>8.3.5</p> <p>8.3.6</p> <p>8.3.7</p> <p>8.3.8</p> <p>8.3.9</p> <p>8.3.10</p> <p>8.3.11</p> <p>8.3.12</p> <p>8.3.13</p> <p>8.3.14</p> <p>8.3.15</p> <p>8.3.16</p> <p>8.3.17</p> <p>8.3.18</p> <p>8.3.19</p> <p>8.7.</p> <p>8.7.1</p> <p>8.7.2 *</p> <p>8.8.</p> <p>8.8.1</p> <p>8.8.2</p> <p>8.8.3</p> <p>8.9.</p> <p>8.9.1 *</p> <p>8.9.2</p> <p>8.9.3</p> <p>8.12.</p> <p>8.12.1 *</p> <p>8.12.2</p> <p>9.1.</p> <p>9.1.1</p> <p>9.1.2 *</p>	<p>Operation (Display designation of this menu level: B)</p> <p>Keypad All accessible All blocked Numeric keypad Toggle weighing platform Zero Tare FN isoTEST Print x10 Toggle gross/net CF Ref OK Toggle Info D ID Mem</p> <p>Automatic shutoff of display and control unit Automatic shutoff acc. to menu item 8 9. No automatic shutoff</p> <p>Display lighting On Off Automatic shutoff acc. to menu item 8 9.</p> <p>Timer After 1 + 1 minute not in use (after 1 min.: warning displayed ²⁾ for 1 minute) After 2 + 2 minutes not in use (after 2 min.: warning displayed ²⁾ for 2 minutes) After 5 + 5 minutes not in use (after 5 min.: warning displayed ²⁾ for 5 minutes)</p> <p>Show geographical data before calibration/adjustment No Yes</p> <p>Restore factory settings in numeric operating menu Yes No</p>
---	---

* Factory setting

¹⁾ Multiple selections possible

²⁾ Warning information: symbol "⚠" flashing (all simultaneously)

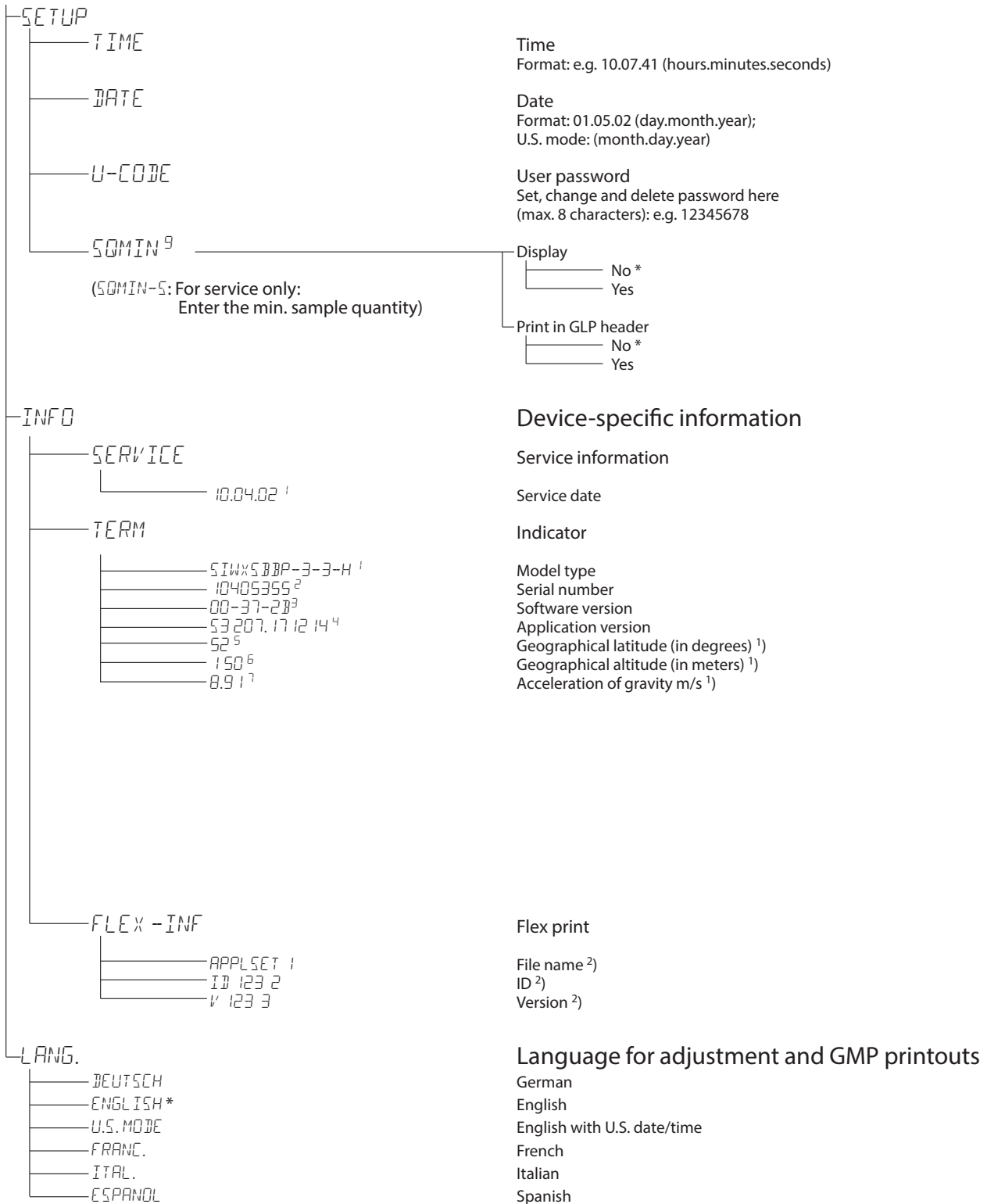

* Factory setting

1) Output: either latitude and altitude or acceleration of gravity (depends on the input before verification)

2) These three parameters are shown for each file loaded.

Operation

Weighing

Weighing $\Delta\bar{\Delta}$

The basic weighing function is always accessible and can be used alone or in combination with application programs, such as Counting, Checkweighing, Weighing in Percent, etc.

Characteristics

- Zeroing $\rightarrow 0 \leftarrow$
- Store the weight on the platform as tare by pressing $\rightarrow T \leftarrow$
- Use the numeric keys to enter a tare weight (press $\rightarrow T \leftarrow$ to save)
- Tare container weight automatically
- Delete tare values by entering 0 (press $\rightarrow T \leftarrow$ to save)
- Press Fn to toggle between:
 - 1st and 2nd weight unit
 - Display value and min. sample quantity "SQmin"
- Press $x10$ to toggle between:
 - 10-fold increased resolution (display max. 5 seconds)
 - Toggle B/G Net:
- Gross or net value

You can configure the Fn key function in the Setup menu via:

FNKEY

- Individual ID codes for weight values
- Print weight value
 - Manually, by pressing $\left[\bar{E} \right]$
 - Automatically (see "Data Output")
 - GMP printout (see "Data Output")
- Restore factory settings by selecting the menu setting:
APPL: (Application)
APPL: DEF_APP: 9. 1

Automatic Taring

The first weight on the scale that exceeds the preset minimum load is stored in the tare memory at stability. The values for subsequent loads are stored as weight values. The scale returns to the initial state when the load is less than 50% of the minimum load. Configure in Setup under:

APPL: (Application)

APPL: A.TARE

Minimum Load

To tare container weights automatically, you need to set a minimum load in the Setup menu, under:

APPL: (Application)

APPL: M.WEIGH

10 setting levels are available for selection. They are defined in scale intervals:

- 1 digit (no minimum load)
- 2 digits
- 5 digits
- 10 digits
- 20 digits
- 50 digits
- 100 digits
- 200 digits
- 500 digits
- 1000 digits

Example: if the scale interval is 1 g and the minimum load is set to 1000 digits (=1000 scale intervals), a load of at least 1000 g is required for autotaring.

Automatic Printing

The first weight value that exceeds the minimum load is printed. Operating menu setting:

SETUP:

PRTPROT: (Printout)

7. 15. (Once at stability)

Device Parameters

Keypad

The keypad can be blocked.

Operating menu setting:

SETUP:

UTILIT: (Operating parameter)

B.3. (Keypad: blocking keys)

The following settings are available:

- *B.3.1. (All keys available)*
- *B.3.2. (All keys blocked except $\left[\bar{V} \right]$ and $\left[\text{SETUP} \right]$)*
- *B.3.3. (All alphanumeric keys blocked)*
- *B.3.4 - B.3.19 (Specified keys blocked (see the menu under "Configuration" for options))*

Display

You can have the display backlighting shut off automatically when not in use.

Operating menu setting:

SETUP:

UTILIT:

B.8. (Display lighting)

Automatic Shutdown

Operating menu setting:

SETUP:

UTILIT:

B.7. (Automatic shutoff of indicator)

Timer

There are three timer settings: two, four or ten minutes:

SETUP:

UTILIT:

B.9. (Timer)

Example :

Switch on the device, zero the scale, tare the container weight, place sample in the container, toggle display to gross weight or to second weight unit or 10-fold resolution, print results

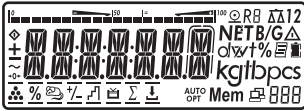

1.) Switching on the scale

All display elements appear for approx. 1 second (display check)

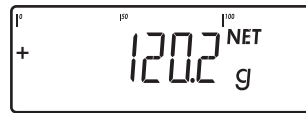

Display with tared scale and filled container

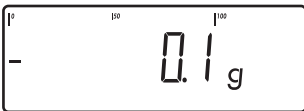

Display with no load on scale



2.) Zero the scale



Display with no load on scale



6.) Toggle display; depending on configuration, display shows

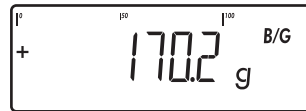

the gross weight (in this example, 50 g for container + 120.2 g substrate)



or

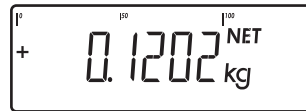

display in 2nd weight unit (in this example kg)

or

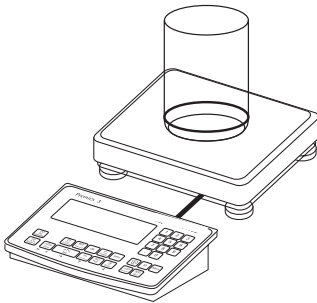

3.) Place container on weighing platform



Display in 10-fold higher resolution



Container weight is displayed

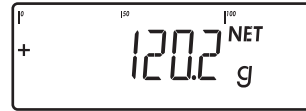

7.) Return to previous display (if 10-fold resolution is shown, display returns automatically after 5 seconds)



4.) Tare the scale



Display (NET) when tared with container



8.) Print results

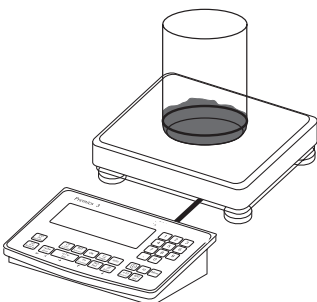

5.) Fill the container (in this example 120.2 g).

```

EISENSCHMIDT
Bovenden
24.02.2017 15:10
-----
G#  +  170.2 g
T   +  50.0 g
N   +  120.2 g
-----
    
```

Example:
Tare the scale by placing a container on the weighing platform



- 1.) Switch on the scale.
The automatic self-test runs. When the weight readout is shown, the scale is ready to operate and automatically set to zero. With no load on the platform, you can zero the weighing platform at any time by pressing $\rightarrow 0 \leftarrow$.

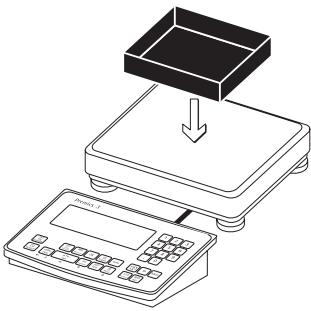

- 2.) Place empty container on the platform.



- 3.) Tare the scale.
Note: If the automatic tare function is enabled, you do not need to press the $\rightarrow T \leftarrow$ key. The tare weight is saved automatically when you place the container on the platform.



Wait until a zero value is displayed together with the NET symbol (net weight).

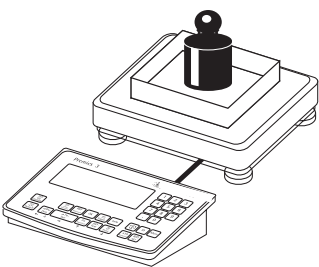

- 4.) Place sample on the platform

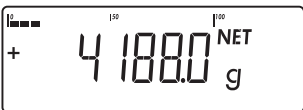

Wait until the weight unit symbol is displayed (indicating stability) and then read off the weight value

Example:
Numeric input of tare weight, print the results



- 1.) Switch on the scale.
The automatic self-test runs. When the weight readout is shown, the scale is ready to operate and automatically set to zero. With no load on the platform, you can zero the weighing platform at any time by pressing $\rightarrow 0 \leftarrow$.

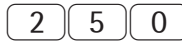

- 2.) Enter the tare weight in the current weight unit using the keypad (in this example, 250 g).

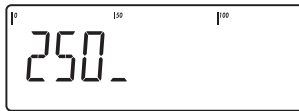

- 3.) Save the tare weight

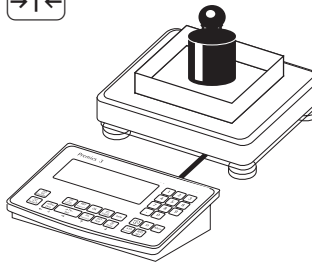

- 4.) Place the sample (in this example, 2 kg) in its container on the scale.



Read the result.



- 5.) Toggle the display from net to gross weight values.
The display shows the gross weight (in this example, 250 g for the container plus 2000 g for the sample).

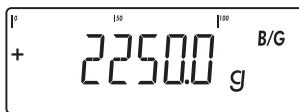

- 6.) Toggle to the previous display.



- 7.) Print the results.

```

-----
G#   +   2.250 kg
T    +   0.000 kg
PT2  +   0.250 kg
N    +   2.000 kg
-----
    
```



Example:
Weighing with variable tare values, printing results, deleting tare values

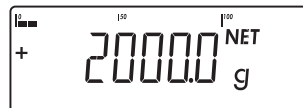

- 1.) Switch on the scale.
The automatic self-test runs. When the weight readout is shown, the scale is ready to operate and automatically set to zero. With no load on the platform, you can zero the weighing platform at any time by pressing $\rightarrow 0 \leftarrow$.

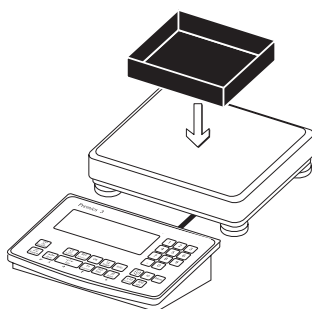

Read the net weight.



- 2.) Place empty container on the platform.



- 7.) Print the results.

G#	+	6.433	kg
T	+	4.183	kg
PT2	+	0.250	kg
N	+	2.000	kg



- 3.) Tare the scale
Note: If the automatic tare function is enabled, you do not need to press the $\rightarrow T \leftarrow$ key. The tare weight is saved automatically when you place the container on the platform.



- 8.) Clear the tare memory:
Enter a zero ("0") using the keypad.



- 9.) Save the value (0) entered (tare values are cleared; the display shows the gross value).

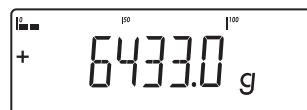

- 10.) Print the results.

G#	+	6.433	kg
T	+	0.000	kg
N	+	6.433	kg

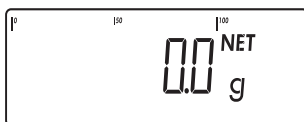

Wait until a zero value is displayed together with the NET symbol (net weight).

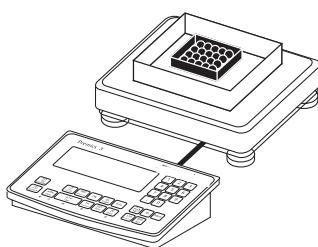

- 4.) Place packaged sample in the container (2nd tare value).

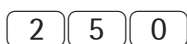

- 5.) Enter the tare weight of the packaging in the current weight unit using the keypad (in this example, 250 g).



- 6.) Save the package weight. The package tare is added to the container tare.

Calibration and Adjustment

Purpose

Perform calibration to determine the difference between the weight value displayed and the actual weight on the platform. Calibration does not entail making any changes within the weighing equipment.

During adjustment, the difference between the measured value displayed and the true weight of a sample is corrected, or is reduced to an allowable level within maximum permissible error limits.

Configuration for Use in Legal Metrology

Configuration of the weighing instrument for use in legal metrology is set by a switch. The switch is located on the back of the weighing platform and covered by a protective cap.

Using a Verified Scale in Legal Metrology in the EU:

The Type-Approval Certificate for verified scales is only valid for non-automatic weighing instruments. For automatic operation with or without additional, integrated equipment, please follow the applicable national regulations for the installation location.

- Before use in legal metrology, the scale should be adjusted via the internal adjustment equipment at the installation location: see the "Internal Adjustment" section in this chapter.
- The temperature range (°C) listed on the ID label should not be exceeded during operation.

For Servicing:

External Adjustment for Verified Scales of Accuracy Class II and III

- External adjustment is blocked in legal metrology (switch cover is sealed)
- External adjustment only possible by removing the seal

If the seal is broken, the validity of verification will become void and you must have your scale re-verified.

Using a Verified Scale in Legal Metrology with Internal Adjustment Equipment:

- Before use in legal metrology, the "internal adjustment" function should be carried out at the installation location.

Calibration Switch

Verification access switch

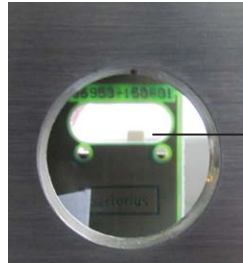

Calibration

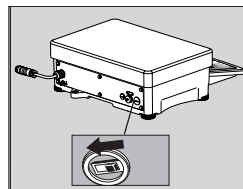

SIWX*DCP

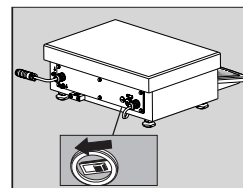

SIWX*DCS

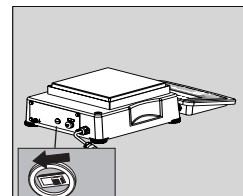

SIWX*BBP

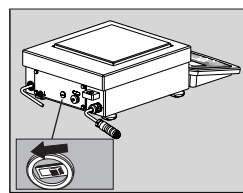

SIWX*BBS

- Switch on the left for use in legal metrology

Characteristics

Which of the following features are available depends on the connected weighing platform. These features are configured in the Setup menu:

- External calibration/adjustment blocked in verified weighing instruments
- External calibration/adjustment with the default weight value or standard weight (not available on verified instruments):
`SETUP`
`WP-1`
`1.9.:` Calibration and Adjustment
- Specify the weight for external calibration/adjustment:
`SETUP`
`WP-1`
`1.18.:` (enter adjustment weight)
- Block the  key to prevent use of the functions described above:
`SETUP`
`WP-1`
`1.9.:` (Block key 1.9.10)
- Calibrate first; then adjust automatically or manually (not for verified weighing instruments):
`SETUP`
`WP-1`
`1.10.:` Calibration/adjustment sequence
- Block external or enable calibration/adjustment:
`SETUP`
`WP-1`
`1.16.:` (External adjustment)

SIWX Models:
Internal Adjustment

Verified versions or with option E7

In the Setup menu (SETUP: WP- 1; 1.9.) "internal adjustment" (SETUP: WP- 1; 1.9.4) must be configured.

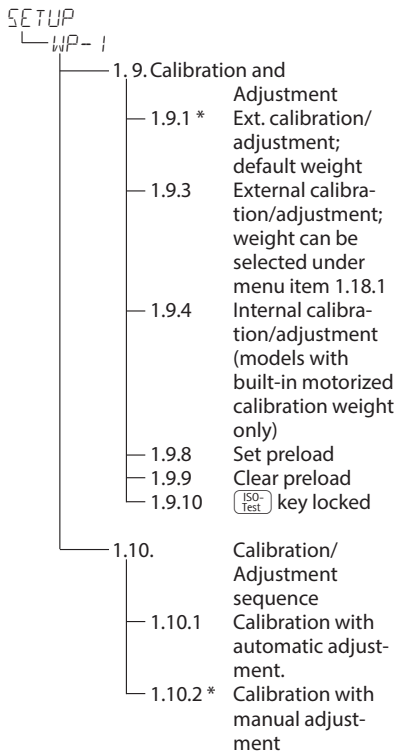

* = Factory setting

The scale housing has a built-in motorized calibration weight.

The calibration/adjustment procedure is performed as follows:

- Select calibration/adjustment: Press the key
- > The internal calibration weight is loaded automatically
- > The scale is adjusted/calibrated
- > In the Setup menu (SETUP: WP- 1; 1.10.) If parameter 1.10.1 is selected in Setup, the scale is adjusted automatically
- > In the Setup menu (SETUP: WP- 1; 1.10.) If parameter 1.10.2 is selected in Setup, the internal adjustment can be stopped without adjusting the scale
- > The internal adjustment weight is unloaded from the scale
- > ISO/GMP-compliant record: see page 91

Setting the Preload

Setup Information

- ⚠ It is only possible to set a preload when the menu access switch is open.
- The key must be allocated to the Set preload function (menu item 1.9.8).
- ⚠ After setting a preload, close the menu access switch and reallocate the original function back to the key (e.g. external calibration/adjustment with user-defined weights) under menu item 1.9.

Clearing the Preload

Setup Information

- ⚠ It is only possible to clear a preload when the menu access switch is open.
- The "Clear Preload" function must be allocated to the key.
- ⚠ After clearing a preload, close the menu access switch and reallocate the original function back to the key (e.g. external calibration/adjustment with user-defined weights) under menu item 1.9.

Preparation

- Switch on the scale: Press the **(ON)** key
- While all segments are lit, press the **(←T→)** key
- Select Setup: Press the **(Fn)** key repeatedly until **SETUP** is displayed

- Open the Setup menu: Press the **(←T→)** key
- Select weighing platform 1 "WP 1": Press the **(←T→)** key or

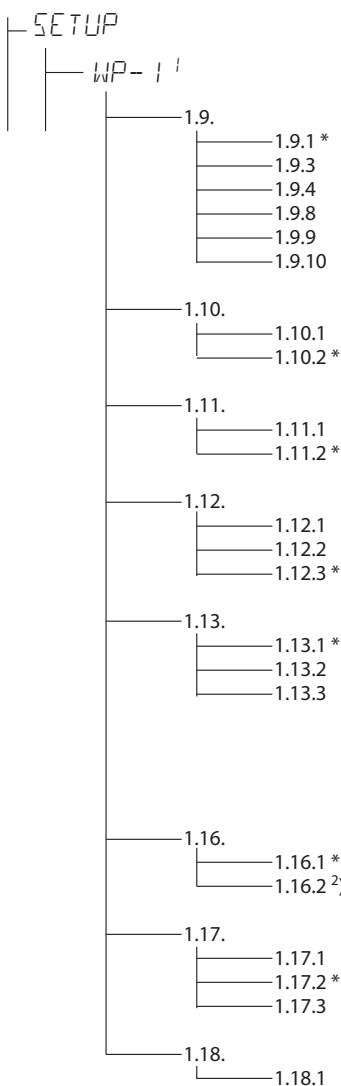

- Calibration and Adjustment
 - Ext. calibration/adjustment; default weight
 - External calibration/adjustment; weight can be selected under menu item 1.18.1
 - Internal calibration/adjustment (models with built-in motorized calibration weight only)
 - Set preload
 - Clear preload
 - (0)** key locked
- Calibration/Adjustment sequence
 - Calibration with automatic adjustment
 - Calibration with manual adjustment
- Zeroing range
 - 1 percent/max. cap.
 - 2 percent/max. cap.
- Initial zero point range
 - Factory setting (depending on the model type)
 - 2 percent/max. cap.
 - 5 percent/max. cap.
- Tare/zero at power on:
 - On
 - Off, load previous tare values
 - Only zero at power on
- External adjustment ¹⁾
 - Activated
 - Blocked
- Adjustment weight unit
 - Gram
 - Kilogram
 - Pound ¹⁾
- Entering adjustment weight
 - External user adjustment weight (enter value, e.g.: 10,000g)

- Save the settings with the **(←T→)** key and exit Setup: Press the **(←0→)** key several times.

¹⁾ Not available on scales verified for use in legal metrology
²⁾ = Factory setting for use in legal metrology
 * Factory Settings

Example:
External calibration and manual adjustment with default weights (weighing parameters: factory settings)



1.) Zero the scale.



2.) Start calibration (e.g., when adjustment prompt flashes WP symbol).



C.E.X.T.D.E.F appears for two seconds.

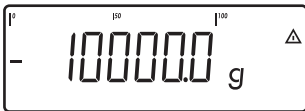

You are prompted to place the required weight on the platform (e.g., 10,000 g).

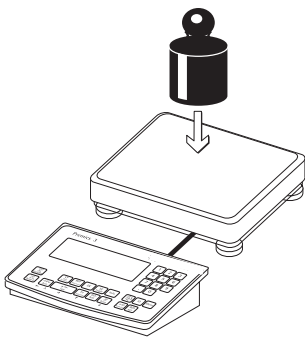

3.) Position the calibration/adjustment weight on the weighing platform.

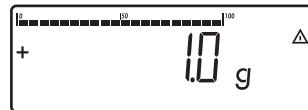
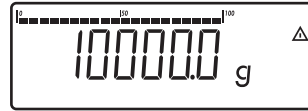

The difference between the weight value and the true weight of the sample will be displayed with plus/minus signs.

```
Ext.      calibration
Targ. +   10000 g
Diff. +           1 g
```

A printout will be generated if the process is cancelled using the →0← key.



4.) Activate calibration/adjustment (press the →0← key to cancel).

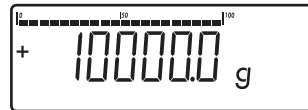

The adjustment weight is displayed once adjustment is finished.

```
-----
24.02.2017    10:15
Typ          SIWX
Ser.no.      12345678
Vers. S3     207.171214
BVers.       00-37-2B
-----
Ext.        Calibrate
Targ. +     10000 g
Diff. +           1 g
Ext.        adjustment
Diff. +           0 g
-----
24.02.2017    10:15
Name:
-----
```

A GMP-compliant printout is generated.

SQmin Function

Purpose

To display the allowable minimum sample quantity "SQmin" (sample quantity minimum) in accordance with the United States Pharmacopoeia (USP). According to USP guidelines, the uncertainty of measurement may not exceed 0.1 % of the sample quantity when substances are weighed with the highest degree of accuracy for volume determination. This additional function ensures that weighing results are within defined tolerance limits corresponding to the requirements of your quality assurance system.

Requirements

The scale must be set up by a service technician to be able to use the SQmin function. The technician will determine the permitted minimum sample quantity and load this to your scale using the guidelines of your QA system. These settings cannot be changed by the user. He or she will document this setting via a "Weighing module test as per USP" certificate in which the measurements and min. sample quantity are logged. The SQmin function ensures that the weighing results correspond to USP guidelines.

Characteristics

- Displaying the minimum sample quality:
The value is shown in the text line for 4 seconds after the **[Fn]** key is pressed.
- If the minimum sample quantity has not been reached:
Symbol displayed: Δ
Weight values are marked with a "!" in the printout.
- GLP header: The minimum sample quantity entered for SQmin can be included on the printout.

Parameter Factory Setting

Display: SQmin OFF

Print in GLP header: OFF

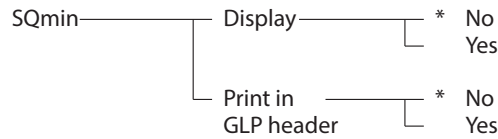

* = Factory setting

See also the chapter on "Configuration": Operating Menu









- Save the settings with the **[→T←]** key and exit Setup: Press the **[→0←]** key several times.

Example

Determining sample weights while monitoring the minimum sample quantity (in this example, SQmin: 100 g)

Settings (different from the factory settings):

Setup: Equipment:
SQmin: Display: on

Step	Press key (or action)	Display/Printout
1. Switch on the scale and enter settings as above		
2. Place the container for the sample on the scale and tare		
3. Measure the weight of a sample (here: If the minimum sample quantity has not been reached)	Place the sample on the scale	
4. Print weight value		N + 90.0 !
5. Measure the weight of another sample (here: If the minimum sample quantity has been exceeded)	Place the sample on the scale	
6. Print weight value		N + 110.0 g
7. Display value of minimum sample quantity for 4 seconds		
8. Weigh other samples as desired		

Individual ID codes (identifiers)

You can assign codes (such as product name, batch number, etc.) for identification of measured values on all application programs.

Characteristics

- Assign up to four ID codes.
- Assign both a name and a value to each ID code.
- Displaying individual IDs: **ID** key
- The name is left-justified and the value is right-justified on the printout. If the entire code is too long for one line, additional lines are printed.
- Enter ID code names in Setup under:
SETUP: PRTPROT: 7.4.
The name can have a max. of 20 characters. No more than 11 characters are displayed during input; all 20 characters are printed.
- Enter up to 40 characters for the value of the ID code. Press the **ID** key to activate the input mode.
- Individual characters of the ID can be deleted using the **CF** key.
- If both the name and value fields are empty, no ID code is printed.
- In the Setup program, you can configure when and whether ID codes are printed (see: Configuring Printouts page 81).

Factory settings for the ID code names



ID1: *ID1*
ID2: *ID2*
ID3: *ID3*
ID4: *ID4*

Factory settings for the ID code values
No default values set.

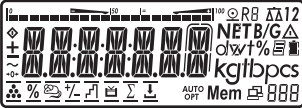

Example:
Enter ID code names.
For ID codes 1 and 2,
enter "Batch no." and "Cust." as names.

 1) Turn on the device.





 2) While all segments are lit, press the  key

The first item in the main menu is shown *APPL*

 3) Select the *SETUP* menu item for the ID code settings (press  repeatedly until *SETUP* is displayed)





 4) Select the Setup menu



5) Select the *PRTPROT* menu item for the ID code settings (press  repeatedly until *PRTPROT* is displayed)

 6) Select level 7.





 7) Press the  key until *7.4.1* appears in the display.









– Select the *7.4.3 ID1* name menu item (press the key until *PRTPROT* appears in the display)

 – Select the *7.4.3 ID1* name menu item (press the key until *PRTPROT* appears in the display)





 8) Press the  key to enable alphanumeric input.



    9) 1. Enter the first character using the  and  keys (in this example: *[*)





 10) Save the character



11) Enter additional letters as described above.

After entering the last letter, save the input by pressing the  key



 – Open the *7.4.4 ID2* name menu item

– Repeat starting with step 8





 12) Exit this menu level and configure other settings as desired, or

13) Press and hold to exit the menu





Example:
Enter ID code values.
The value "123" should be entered for ID code 1.



 1) Activate input of ID code values.





   2) Enter the value for ID code 1 (in this example: *123*).

·

·

·

5) Exit after ID4 using the  key



·

·

Application Programs

Applications 1 - 3: Overview

Application

- Basic weighing
- Averaging (Animal Weighing)
- Send print job/data record to peripheral device
- Label printer
- Counting
- Totalizing
- Checkweighing
- Batching/Counting to target value
- Product data memory

Function

- Zero
- Tare
- Date/time
- ID codes (4 codes, 40 characters each)

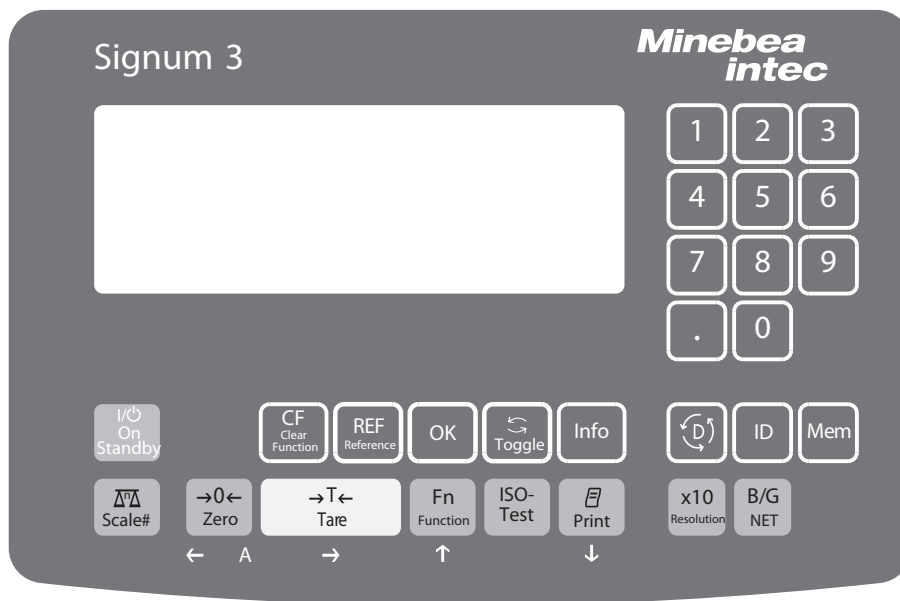

The following table shows how the application programs can be combined.

Each row represents one combination. The basic weighing function is available at all times; it does not need to be combined with a computational function.

Select programs one after the other: Toggle using the  key

Application 1 (Basic Function)	Application 2 (Monitoring Function)	Application 3 (Cumulative-value Function)
Counting	–	Totalizing
Counting	Checkweighing	Totalizing
Counting	Checkweighing	–
Counting	Classification	–
Neutral Measurement	–	Totalizing
Neutral Measurement	Checkweighing	Totalizing
Neutral Measurement	Checkweighing	–
Neutral Measurement	Classification	–
Animal Weighing	–	Totalizing
Animal Weighing	Checkweighing	Totalizing
Animal Weighing	Checkweighing	–
Animal Weighing	Classification	–
Weighing in Percent	–	Totalizing
Weighing in Percent	Checkweighing	Totalizing
Weighing in Percent	Checkweighing	–
Weighing in Percent	Classification	–
–	–	Net-total formulation
–	Checkweighing	Totalizing

Counting Application ❁

With the Counting application, you can determine the number of parts which each have approximately equal weight.

Characteristics

- Save the reference weight "wRef" from the weighing platform
- Enter the reference sample weight "wRef" using the keypad
- Enter the reference sample quantity "nRef" using the keypad
- Automatic average piece weight updating
- Activate Info mode with the **[Info]** key
- Toggle the display between quantity and weight using the **[↔]** key
- Define the level of accuracy (display resolution) applied when a calculated reference sample quantity is saved
- Automatic taring of container weight. Configured in Setup under: (Autotare 1st weight)
APPL: A.TARE
- Automatic initialization when the scale is switched on. The indicator is initialized with the most recently used values for reference sample quantity "nRef" and reference sample weight "wRef." Configured in Setup under: (Start app. with last values)
APPL: A.START
- Exit application, delete parameters: The value of the reference sample weight in the reference memory remains active until it is deleted, overwritten or the application is changed using the **[CF]** key. The reference sample weight also remains saved after the scale is turned off.

You can assign different functions to the **[CF]** key for deleting applications. When you clear applications, you can delete either the data stored for all applications or just selected data stored for the active application. Configured in Setup under:

APPL: SEL.CF.

(Sel. **[CF]** function key **[CF]** in applications)

- Tare function:
 - 1) If you store a tare (weight value) by pressing the **[T+]** key, you can later enter a tare value manually. The tare value you enter is added to the stored tare value. Setting: menu code 3.25.1 (factory setting)
 - 2) A tare value entered manually overwrites a stored tare value (weight value). If you enter a tare value manually, a tare value (weight value) stored later overwrites the manually entered value. Setting: Menu code 3.25.2
 Configured in Setup under:
APPL: TARE.F: 3.25.
- Restore factory default settings. Configured in Setup under:
APPL: DEF.APP: 9. 1.

Before the quantity on the platform can be calculated, the average piece weight (reference sample weight) must be entered in the application. There are three ways to enter this value in the program:

- Calculation:
 - Place the number of parts defined as the reference sample quantity on the weighing platform and calculate the average piece weight by pressing the **[OK]** key
 - Alternatively, using the **[REF]** key, you can place any number of parts on the weighing platform, enter the number of parts using the keypad, and then calculate the average piece weight by pressing the **[OK]** key
 How the reference weight is calculated depends on the application setting for resolution. The value is either rounded off in accordance with the display resolution, or saved with 10-fold or 100-fold resolution, or with the maximum internal resolution of the weighing platform.
- Entering a reference sample weight (i.e., the weight of one piece) using the keypad and saving it with the **[OK]** key

After initialization, you can use the connected weighing platform to count parts.

The initial application values remain active until deleted by pressing the **[CF]** key or until overwritten by a new value. They remain saved after the scale is switched off.

Preparation

- Turn scale on: Press the **(ON)** key
- While all segments are lit, press the **(T←)** key
- Select Setup: Press the **(Fn)** key repeatedly until *APPL* is displayed
- Confirm *APPL*: Press the **(T←)** key
- Select the Counting application: Press the **(Fn)** key repeatedly and confirm with the **(T←)** key

Counting application parameters

3.6.	Minimum load for initialization	
3.6.1*	1 digit	
3.6.2	2 digits	
3.6.3	5 digits	
3.6.4	10 digits	
3.6.5	20 digits	
3.6.6	50 digits	
3.6.7	100 digits	
3.6.8	200 digits	
3.6.9	500 digits	
3.6.10	1000 digits	
3.9.	Resolution for calculation of reference value	
3.9.1*	Display accuracy	
3.9.2	Display accuracy + 1 decimal place	
3.9.3	Display accuracy + 2 decimal places	
3.9.4	Internal resolution	
3.11	Parameter for saving weight values	
3.11.1*	With stability	
3.11.2	With increased stability	
3.12.	Average piece weight updating	
3.12.1	Off	
3.12.3*	Automatic	

* = Factory setting

- Save the settings with the **(T←)** key and exit Setup: Press the **(0←)** key several times.

Parameter for Saving Weight Values

The weight on the platform is saved as a reference value when the platform has stabilized. "Stability" is defined as the point at which the fluctuation of a measured value lies within a defined tolerance range. The narrower the tolerance range, the more stable the platform is at "stability".

In Setup menu:

APPL 1: COUNT: 3.11.

You can define whether the value is saved when "standard stability" is reached, or only at "increased stability" (narrower tolerance range). If you select "increased stability," the value saved for average piece weight will be more accurate and the results more reproducible, but the response time of the weighing platform might be longer.

Accuracy of Average Piece Weight Calculation

The resolution applied for calculating the reference weight is defined in Setup under:

APPL 1: COUNT: 3.9.

The resolution for calculating the reference weight is increased if "+1 decimal place," "+2 decimal places" or "Internal resolution" is selected. With the "+1 decimal place" setting, the net value is determined to one additional decimal place (i.e., display accuracy x 10); "+2 decimal places" increases display accuracy + 100, and so on up to the maximum resolution available.

Minimum Load

The minimum load required for initialization of the weighing platform is configured in Setup under:

APPL 1: COUNT: 3.6.

Once the limit is exceeded by the load, initialization can begin.

If the load on platform is too light, the following will occur when you try to save a value:

- Error code *INF 29* appears,
- The weighing platform is not initialized
- The preset reference sample quantity is saved

The minimum load required for automatic taring of the container weight on the platform (first weight) is configured in Setup under:

APPL: M.WEIGH: 3.5.

You can choose from the following 10 levels for this setting:

- 1 digit
- 2 digits
- 5 digits
- 10 digits
- 20 digits
- 50 digits
- 100 digits
- 200 digits
- 500 digits
- 1000 digits

The "digits" here refer to the scale intervals in the connected weighing platform. If the interval of the connected platform is 1 g, for example, and 1000 digits are required, you must place at least 1000 g (= 1000 intervals) on the weighing platform for initialization.

Average Piece Weight Updating

In Setup menu:

APPL 1: COUNT: 3.12.

You can define whether or not the reference sample weight is updated automatically during weighing. The reference sample weight is updated automatically only when the following 6 criteria are met:

1. The menu item must be set to 3.12.3 in Setup.
2. The current piece count exceeds the original piece count by at least two.
3. The current piece count is less than twice the original piece count (does not apply for the first updating operation if the piece count is entered using the keypad)
4. The current piece count is less than 1000.

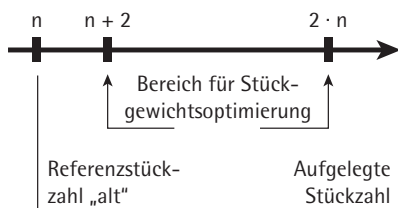

5. The internally calculated piece count (such as 17.24 pcs) differs by less than ± 0.3 pcs from the nearest whole number (in this example: 17)
6. The weighing platform is stable in accordance with the parameter defined for saving weights.

If automatic average piece weight updating is selected in the Setup menu and the piece count (pcs) is displayed, the *AUTO* symbol is displayed below the bar graph. If the reference sample weight has been updated since you began weighing, the text line shows the "optimized" code (*OPT.*). During an updating operation, *OPT* and the updated piece count are displayed briefly in the measured value line.

The new reference sample weight and reference sample quantity are saved.

Example:
 Determining the number of uncounted parts.
 Settings (different from the factory settings):
 Setup: Application 1: Counting
 Setup: Device Parameters: Printout: PRTPROT: 7.6
 then select the menu line items of your choice (see "Configuration" for options)

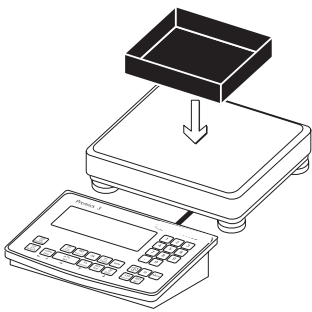

1.) Place empty container on the platform.

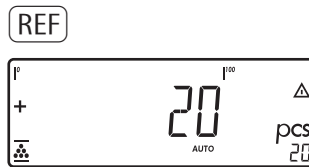

5.) Start calculation of the reference sample weight

Set the number of reference parts using **REF**: 1, 2, 5, 10, 20, etc.
 Start the reference sample weight calculation using the **OK** key.

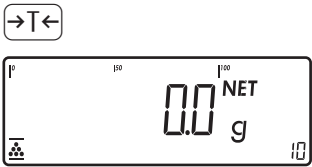

2.) Tare the scale.
 Note: If the automatic tare function is enabled, you do not need to press the **T** key to tare the platform; the tare weight is saved automatically when you place the container on the platform.

If the weight is too light, reduce the minimum load setting or increase the reference sample quantity setting in the main display **INF 29** and the number of parts in the container.

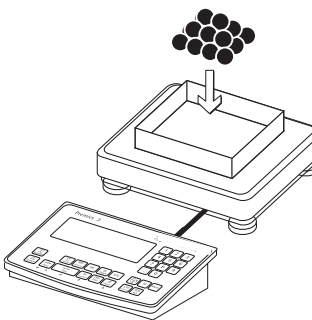

3.) Place a number of parts in the container for the reference quantity (in this example, 20 pcs).

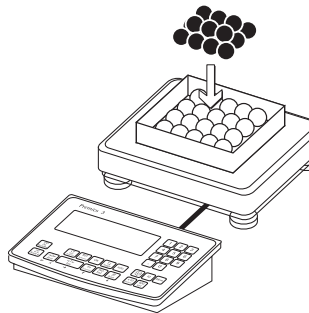

6.) Add a quantity of uncounted parts to the container

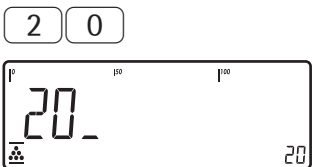

4.) Enter the number of parts using the keypad or using **REF**: 1, 2, 5, 10, 20, etc.

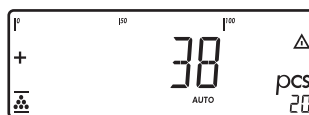

Read the result

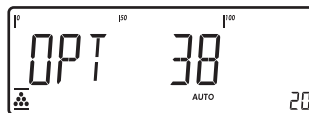

OPT is displayed if automatic reference sample updating is enabled.



7.) Print the results

```
nRef +          38 pcs
wRef + 0.003280 kg
G#   + 0.373 kg
T    + 0.248 kg
N    + 0.125 kg





Qnt          38 pcs
-----
```

see: **Configuring Printouts**



Neutral Measurement Application



With this application you can use your weighing platform to measure the length, surface and volume of parts that have roughly the same specific weight. The  symbol is displayed as the weight unit.

Characteristics







- Save the reference weight "wRef" from the weighing platform
 - Enter the reference weight "wRef" using the keypad
 - Enter the calculation factor "nRef" using the keypad
 - Activate Info mode with the  key
 - Toggle the display between measurement and weight using the  key
 - The level of accuracy (display resolution) can be set when the calculated reference weight is applied
 - Automatic taring of container weight. Configured in Setup under: *APPL: A.TARE: 3.7.*
 - Automatic initialization when the scale is switched on. The indicator is initialized with the most recently used calculation factor "nRef" and reference weight "wRef." Configured in Setup under: *APPL: A.START: 3.8.*
 - Exit application, delete parameters: The value of the reference sample weight in the reference memory remains active until it is deleted, overwritten or the application is changed using the  key. The reference sample weight also remains saved after the scale is turned off.
- You can assign different functions to the  key for deleting applications. When you clear applications, you can delete either the data stored for all applications or just selected data stored for the active application. Configured in Setup under: *APPL: SEL.CF: 3.24.* (Sel. CF function key  in applications)

- Tare function:
 - 1) If you store a tare (weight value) by pressing the  key, you can later enter a tare value manually. The tare value you enter is added to the stored tare value. Setting: menu code 3.25.1 (factory setting)
 - 2) A tare value entered manually overwrites a stored tare value (weight value). If you enter a tare value manually, a tare value (weight value) stored later overwrites the manually entered value. Setting: Menu code 3.25.2
 Configured in Setup under: *APPL: TARE.F: 3.25.*
 - Restore factory default settings. Configured in Setup under: *APPL: DEF.APP: 9.1.*

In order to calculate the length, surface or volume of a given sample, the average weight of a reference quantity of the sample must be known (in the example below, the reference is 1 meter of electrical cable). There are three ways to enter the reference weight in the program:
 - Calculation:
 - Place the reference quantity (defined by the calculation factor) on the connected weighing platform and calculate the reference sample weight by pressing the  key
 - Place any amount of the sample material on the connected weighing platform, enter the calculation factor through the keypad, and press the  key to calculated reference sample weight.

How the reference weight is calculated depends on the application setting for resolution. The value is either rounded off in accordance with the display resolution, or saved with 10-fold or 100-fold internal resolution, or with the maximum internal resolution of the weighing platform.
 - Enter the reference weight (i.e., the weight of one meter of electrical cable) using the keypad and press  to save it.
- The initial application values remain active until deleted by pressing the  key or until overwritten by a new value. They remain saved after the scale is switched off.



Preparation

- Turn scale on: Press the  key
- While all segments are lit, press the  key
- Select Setup: Press the  key repeatedly until *APPL* is displayed
- Confirm *APPL*: Press the  key
- Select the Neutral Measurement application: Press the  key repeatedly and confirm with the  key

NeutralMeasurementApplicationParameters

— 3.6.	Minimum load for initialization	
— 3.6.1*	1 digit	
— 3.6.2	2 digits	
— 3.6.3	5 digits	
— 3.6.4	10 digits	
— 3.6.5	20 digits	
— 3.6.6	50 digits	
— 3.6.7	100 digits	
— 3.6.8	200 digits	
— 3.6.9	500 digits	
— 3.6.10	1000 digits	
— 3.9.	Reference value calculation resolution	
— 3.9.1*	Display accuracy	
— 3.9.2	Display accuracy + 1 decimal place	
— 3.9.3	Display accuracy + 2 decimal places	
— 3.9.4	Internal resolution	
— 3.10.	Decimal places in displayed result	
— 3.10.1*	None	
— 3.10.2	1 decimal place	
— 3.10.3	2 decimal places	
— 3.10.4	3 decimal places	
— 3.11.	Parameter for saving weight values	
— 3.11.1*	With stability	
— 3.11.2	With increased stability	

* = Factory setting

- Save the settings with the  key and exit Setup: Press the  key several times.

Parameter for Saving Weight Values

The reference weight is saved when the scale has stabilized.

“Stability” is defined as the point at which the fluctuation of a measured value lies within a defined tolerance range. The narrower the tolerance range, the more stable the platform is at “stability”.

In Setup menu:

APPL 1:

NEUTR.M:3.11.

You can define whether the value is saved when “standard stability” is reached, or only at “increased stability” (narrower tolerance range). If you select “increased stability”, the reference weight saved will be more accurate and the results more reproducible, but the response time of the weighing platform might be longer.

Accuracy Level for Calculation of Reference Value

The resolution applied for calculating the reference weight is defined in Setup under:

APPL 1:

NEUTR.M:3.9.

The resolution for calculating the reference weight is increased if “+1 decimal place”, “+2 decimal places” or “Internal resolution” is selected. With the “+1 decimal place” setting, the net value is determined to one additional decimal place (i.e., display accuracy x 10); “+2 decimal places” increases display accuracy x 100, and so on up to the maximum resolution available.

Decimal Places in Displayed Result

In neutral measurement, not only whole numbers but also decimal numbers (for example, 1.25 g electrical cabling) can be displayed. The number of decimal places displayed in neutral measurement is configured in Setup under:

APPL 1:

NEUTR.M:3.10.

Minimum Load

The minimum load required for initialization of the weighing platform is configured in Setup under:

APPL 1:

NEUTR.M:3.6.

Once the limit is exceeded by the load, initialization can begin.

If the load on platform is too light, the following will occur when you try to save a value:

- Error code *INF 29* appears,
- A warning signal is emitted (double-beep)
- The weighing platform is not initialized
- The preset calculation factor is saved

The minimum load required for automatic taring of the container weight on the platform (first weight) is configured in Setup under:

APPL 1: M.WEIGH:3.5.

You can choose from the following 10 levels for this setting:

- 1 digit
- 2 digits
- 5 digits
- 10 digits
- 20 digits
- 50 digits
- 100 digits
- 200 digits
- 500 digits
- 1000 digits

The “digits” here refer to the scale intervals in the connected weighing platform. If the interval of the connected platform is 1 g, for example, and 1000 digits are required, you must place at least 1000 g (= 1000 intervals) on the weighing platform for initialization.

Example:
 Measuring 25 m of electrical cable.
 Settings (different from the factory settings):
 Setup: Application 1: Neutral Measurement
 Setup: Printout, PRTPROT 7.6.
 then select the menu line items of your choice

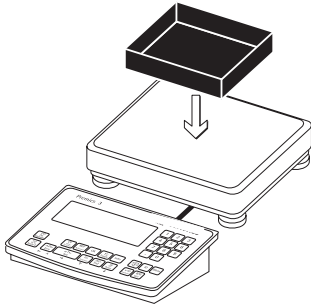

1.) Place empty container on the platform.

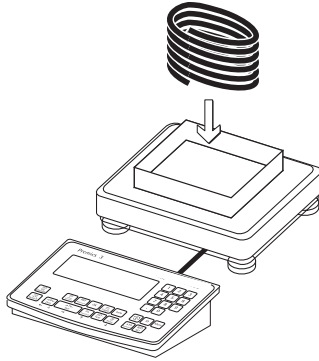

5.) Place the desired amount of cable in the container



2.) Tare the scale.
 Note: If the automatic tare function is enabled, you do not need to press the  key to tare the platform; the tare weight is saved automatically when you place the container on the platform

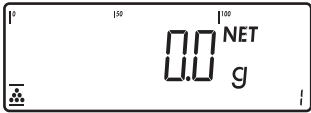

Read the result

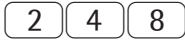
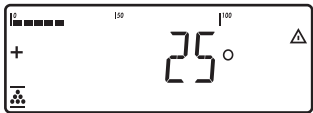

3.) Enter the weight of 1 meter of cable using the keypad (in this example, 248 g)

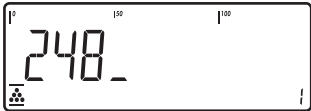

6.) Print the results



4.) Save the value entered as the reference weight

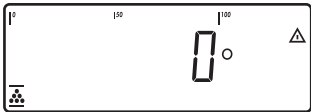

nRef	+	1	o
wRef	+	0.248	kg
G#	+	6.794	kg
T	+	0.541	kg
N	+	6.253	kg

see:
 Configuring Printouts



Qnt	25	o

Averaging (Animal Weighing) Application

With the Averaging application, you can use your weighing platform for calculating weights as the average of a number of individual weighing operations. These individual operations are also known as “subweighing operations.”

This function is used to determine weights under unstable ambient conditions or for weighing unstable samples (such as live animals).

Characteristics

- Averaging started manually or automatically. Configured in Setup under:
APPL 1: ANIM.WG: 3.18.
With manual start selected, the averaging routine begins when you press a key (provided the start conditions are met). With automatic start selected, averaging begins when you place the first load on the platform (provided the start conditions are met).
- Enter the number of subweighing operations using the keypad
- Info mode
- Toggle the display from “result of last measurement” to “current weight” by pressing the  key
- Automatic printout configured in Setup under:
*APPL 1:
ANIM.WG: 3.20.*
- Automatic taring of container weight. Configured in Setup under:
*APPL 1:
ANIM.WG: 3.7.*
- Automatic start of averaging when the scale is turned on and a sample placed on the platform (provided start conditions are met). Configured in Setup under:
APPL: A.START: 3.8.
- Exit application, delete parameters: The number of measurements remain in memory until it is deleted, overwritten or the application is changed using the  key. The number of measurements also remains saved after the scale is turned off.

You can assign different functions to the  key for deleting applications. When you clear applications, you can delete either the data stored for all applications or just selected data stored for the active application. Configured in Setup under:



APPL: SEL.CF: 3.24.
(Sel. CF function key  in applications)







- Tare function:
If you store a tare (weight value) by pressing the  key, you can later enter a value manually. The tare value you enter is added to the stored tare value.
Setting: menu code 3.25.1 (factory setting)
A tare value entered manually overwrites a stored tare value (weight value). If you enter a tare value manually, a tare value (weight value) stored later overwrites the manually entered value. Setting: menu code 3.25.2
Configured in Setup under: Signum® 2
APPL: TARE.F: 3.25.
- Restore factory default settings. Configured in Setup under:
APPL: DEF.APP: 9.1.

A number of subweighing operations are required to form the basis for calculation of an average weight. You can enter the desired number of subweighing operations using the keypad.

The number you enter is active until it is overwritten by another number. It also remains in memory when you switch to a different application program, or turn off the scale.

There are three ways to start the averaging routine:



- Manual start with preset number of sub-weighing operations: Place the sample on the platform and press the  key
- Manual start with user-defined number of subweighing operations: Place the sample on the platform and enter the number of weighing operations using the keypad. Press the  key to save the number entered and begin weighing
- Automatic start with preset number of subweighing operations: Measurement begins when you place the first sample on the platform, provided the start conditions are met.

- Preparation
- Turn scale on: Press the  key
 - While all segments are lit, press the  key
 - Select Setup: Press the  key repeatedly until *APPL* is displayed
 - Confirm *APPL*: Press the  key
 - Select the Animal Weighing application: Press the  key repeatedly and confirm with the  key

Application Parameters: Animal Weighing

—	3.6.	Minimum load for start
—	3.6.1*	1 digit
—	3.6.2	2 digits
—	3.6.3	5 digits
—	3.6.4	10 digits
—	3.6.5	20 digits
—	3.6.6	50 digits
—	3.6.7	100 digits
—	3.6.8	200 digits
—	3.6.9	500 digits
—	3.6.10	1000 digits
—	3.18.	Start of averaging
—	3.18.1*	Manually
—	3.18.2	Automatic
—	3.19.	Animal activity
—	3.19.1	0.1% of animal/object
—	3.19.2*	0.2% of animal/object
—	3.19.3	0.5% of animal/object
—	3.19.4	1% of animal/object
—	3.19.5	2% of animal/object
—	3.19.6	5% of animal/object
—	3.19.7	10% of animal/object
—	3.19.8	20% of animal/object
—	3.19.9	50% of animal/object
—	3.19.10	100% of animal/object
—	3.20.	Auto printout of results
—	3.20.1*	Off
—	3.20.2	On
—	3.21.	Static display of result after load removed
—	3.21.1*	Display is fixed until unload threshold reached
—	3.21.2	Fixed display until the  key is pressed

* = Factory setting

- Save the settings with the  key and exit Setup: Press the  key several times.

Minimum Load

The minimum load required for initialization of the averaging routine is configured in Setup under:

APPL 1:

ANIM.WG: 3.6.

Setting a minimum load for averaging can be especially useful if you configure automatic start of measurement.

The minimum load required for automatic taring of the container weight on the platform (first weight), or for automatic printout of results, is configured in Setup under:

APPL: A.TARE: 3.5.

You can choose from the following 10 levels for this setting:

- 1 digit
- 2 digits
- 5 digits
- 10 digits
- 20 digits
- 50 digits
- 100 digits
- 200 digits
- 500 digits
- 1000 digits

The “digits” here refer to the scale intervals in the connected weighing platform. If the interval of the connected platform is 1 g, for example, and 1000 digits are required, you must place at least 1000 g (= 1000 intervals) on the weighing platform to start the averaging routine.

Starting the Measurements

The averaging routine does not begin until the fluctuation in weight value remains below a defined threshold over three consecutive measurements. The tolerance limit is defined as a percentage of the animal or object weight (for example, 0.1%, 0.2%, ..., 50%, 100%), configured in Setup under:

APPL 1:

ANIM.WG: 3.19.

If the “Averaging” parameter is set to 2%, for example, and the animal or object weighs 10 kg, measurement does not begin until the fluctuation in weight value remains below 200 g during three consecutive measurements.

Display

A calculated average value is shown continuously on the main display. The  Symbol (indicating a calculated value) is also displayed.



You can toggle between this display to a readout of the current weight on the platform by pressing the  key.

In the Setup menu, under:

APPL 1:

ANIM.WG: 3.21.

you can select “Display is static until unload threshold reached” to have the display switch automatically to the weight readout when you unload the weighing platform (i.e., when the load is less than half the minimum load). The result of the most recent averaging operation is not saved.

If you select “Display is static until the  key is pressed,” the calculated average remains displayed even after the weighing platform is unloaded, until you press the  key to begin a new measurement.

Example:
 Measuring the weight of one mouse.
 Settings (different from the factory settings):
 Setup: Application 1: Animal Weighing
 Setup: Printout; PRTPROT 7.6 then select the menu line items of your choice

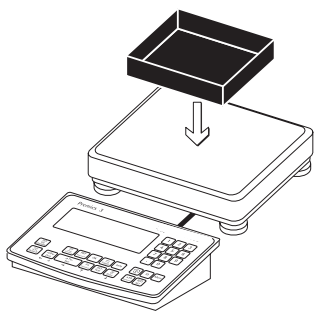

Place empty container on the platform.



The averaging routine does not begin until the fluctuation in weight value remains below a defined threshold over three consecutive measurements. The number of subweighing operations remaining is shown in the numeric display.

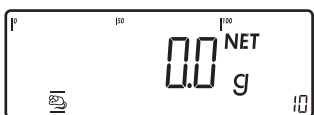

1.) Tare the scale.
 Note: If the automatic tare function is enabled, you do not need to press the  key to tare the platform; the tare weight is saved automatically when you place the container on the platform.



Read off the result of averaging



5.) Print the results.
 Note: If automatic printout of results is enabled, you do not need to press the  key. The results are printed automatically.

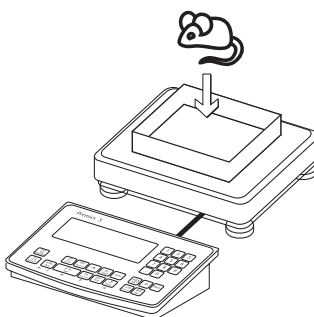

2.) Place 1st animal in container

```
mDef + 20
T + 0.292 kg
x-Net + 0.183 kg
-----
```

see chapter
 Configuring Printouts

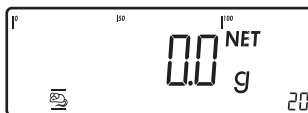

When you unload the weighing platform, the display switches to the weight readout automatically, unless configured otherwise in Setup. The weighing instrument is ready for the next measurement.

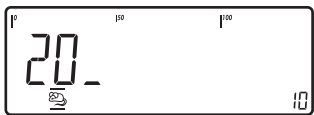

3.) Enter the number of subweighing operations using the keypad (in this example, 20 measurements).



4.) Save the value entered and begin averaging

Weighing in Percent Application %

With the Weighing in Percent application, you can use your weighing platform to obtain weight readouts in percent which are in proportion to a reference weight.
% is displayed as the weight unit.

Characteristics

- Save the current weight value as reference weight "pRef"
- Enter the reference weight "Wxx%" for 100% using the keypad
- Enter the reference percentage "pRef" using the keypad
- Display result as loss (difference) or residue
- Display up to 3 decimal places.
Configured in Setup under:
APPL: I:
PERC.WG: 3. 10.
- Activate Info mode with the **[Info]** key
- Toggle the display between percent and weight using the **[↔]** key.
- Automatic taring of container weight.
Configured in Setup under:
APPL: A.TARE: 3. 7.
- Automatic initialization when the scale is switched on. The application is initialized with the most recently saved data. Configured in Setup under:
APPL: A.START: 3. 8.
- Exit application, delete parameters: The value of the reference weight in the memory remains active until it is deleted, overwritten or the application is changed using the **[CF]** key. The value also remains saved after the scale is turned off.
- You can assign different functions to the **[CF]** key for deleting applications. When you clear applications, you can delete either the data stored for all applications or just selected data stored for the active application. Configured in Setup under:
APPL: SEL.CF: 3. 24.
(Sel. CF function key **[CF]** in applications)
- Tare function:
 - 1) If you store a tare (weight value) by pressing the **[→T←]** key, you can later enter a tare value manually. The tare value you enter is added to the stored tare value.
Setting: menu code 3.25.1 (factory setting)
 - 2) A tare value entered manually overwrites a stored tare value (weight value).
If you enter a tare value manually, a tare value (weight value) stored later overwrites the manually entered value.
Setting: menu code 3.25.2
Configured in Setup under:
APPL: TARE.F: 3.25.
- Restore factory default settings.
Configured in Setup under:
APPL: DEF.APP: 9. 1.

To determine the weight of a sample relative to a reference weight, you need to define the reference percentage value. There are three ways to enter this value in the application program:

- Calculation:
- Place the reference quantity (defined by the reference percentage) on the connected weighing platform and press the **[OK]** key to initialize the application.
- Place any amount of the sample material on the connected weighing platform, enter the reference percentage through the keypad, and press the **[REF]** key to initialize the application. How the reference weight is calculated depends on the application setting that defines "Accuracy for saving weights". The value is either rounded off in accordance with the display resolution, or saved with 10-fold or 100-fold resolution, or with the maximum internal resolution of the weighing platform.
- By entering the reference weight for 100% using the keypad and pressing the **[OK]** key to initialize the application.

The initialization data remains valid until deleted by pressing the **[CF]** key or until overwritten by a new value. They remain saved after the Signum® is switched off.

Preparation

- Turn scale on: Press the **[I/O]** key
- While all segments are lit, press the **[→T←]** key
- Select Setup: Press the **[Fn]** key repeatedly until *APPL* is displayed
- Confirm *APPL*: Press the **[→T←]** key
- Select the Weighing in Percent application: Press the **[Fn]** key repeatedly and confirm with the **[→T←]** key

Weighing in Percent Application Parameters

3.6.	Minimum load for initialization	
3.6.1*	1 digit	
3.6.2	2 digits	
3.6.3	5 digits	
3.6.4	10 digits	
3.6.5	20 digits	
3.6.6	50 digits	
3.6.7	100 digits	
3.6.8	200 digits	
3.6.9	500 digits	
3.6.10	1000 digits	
3.9.	Reference value calculation resolution	
3.9.1*	Display accuracy	
3.9.2	Display accuracy + 1 decimal place	
3.9.3	Display accuracy + 2 decimal places	
3.9.4	Internal resolution	
3.10.	Decimal places in displayed result	
3.10.1*	None	
3.10.2	1 decimal place	
3.10.3	2 decimal places	
3.10.4	3 decimal places	
3.11	Parameter for saving weight values	
3.11.1*	With stability	
3.11.2	With increased stability	
3.15.	Display of calculated values	
3.15.1*	Residue	
3.15.2	Loss	

* = Factory setting

- Save the settings with the **[→T←]** key and exit Setup: Press the **[→O←]** key several times.

Parameter for Saving Weight Values

The reference weight is saved when the scale has stabilized.

“Stability” is defined as the point at which the fluctuation of a measured value lies within a defined tolerance range. The narrower the tolerance range, the more stable the platform is at “stability”.

In Setup menu:

APPL 1:

PERC.WG: 3.11.

You can define whether the value is saved when “standard stability” is reached, or only at “increased stability” (narrower tolerance range). If you select “increased stability”, the reference weight saved will be more accurate and the results more reproducible, but the response time of the weighing platform might be longer.

Accuracy of Average Piece Weight Calculation

The resolution applied for calculating the reference weight is defined in Setup under:

APPL 1:

PERC.WG: 3.9.

The resolution for calculating the reference weight is increased if “+1 decimal place”, “+2 decimal places” or “Internal resolution” is selected. With the “+1 decimal place” setting, the net value is determined to one additional decimal place (i.e., display accuracy x 10); “+2 decimal places” increases display accuracy x 100, and so on up to the maximum resolution available.

Display of Results

With the Weighing in Percent application, the result can be displayed as a remainder or loss. Configured in Setup under:

APPL 1:

PERC.WG: 3.15.

Equations:

$$\text{Residue} = (\text{current weight} - 100\% \text{ weight}) / * 100$$

$$\text{Loss} = (\text{current weight} - 100\% \text{ weight}) / 100\% \text{ weight} * 100$$

Minimum Load

The minimum load required for initialization of the weighing platform is configured in Setup under:

APPL 1:

PERC.WG: 3.6.

Once the limit is exceeded by the load, initialization can begin. If the load on platform is too light, the following will occur when you try to save a value:

- Error code *INF 29* appears,
- The weighing platform is not initialized
- The preset reference percentage is saved

The minimum load required for automatic taring of the container weight on the platform (first weight) is configured in Setup under:

APPL:M.WEIGH: 3.5.

You can choose from the following 10 levels for this setting:

1 digit
2 digits
5 digits
10 digits
20 digits
50 digits
100 digits
200 digits
500 digits
1000 digits

The “digits” here refer to the scale intervals in the connected weighing platform. If the interval of the connected platform is 1 g, for example, and 1000 digits are required, you must place at least 1000 g (= 1000 intervals) on the weighing platform for initialization.

Example:
 Weighing in 100% of a sample material.
 Settings (different from the factory settings):
 Setup: Application 1: Weighing in percent
 Setup: Printout, PRTPROT 7.6, then select the menu line items of your choice

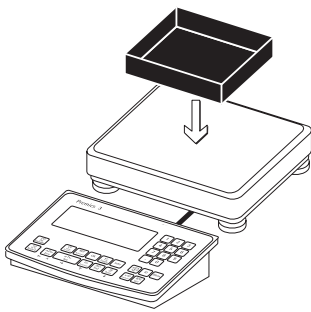

1.) Place empty container on the platform.



If the weight is too light, an error code is shown in the main display *INF 29*

Reduce the minimum load setting



2.) Tare the scale.
 Note: If the automatic tare function is enabled, you do not need to press the  key to tare the platform; the tare weight is saved automatically when you place the container on the platform

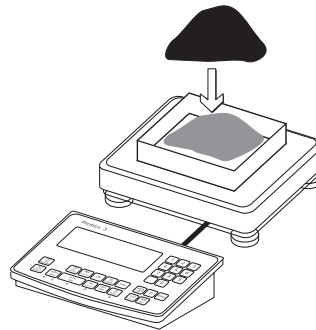

5.) Continuing filling the container until the target amount is reached (in this example, 100%)

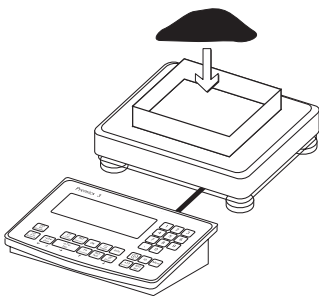

3.) Add reference material in accordance with reference percentage (in this example, 85 g)

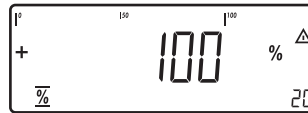

4.) Begin calculation of reference weight. The calculation is based on the active net weight value and the reference percentage entered



6.) Print the results

pRef	+	20 %
wRef	+	0.085 kg
G#	+	1.080 kg
T	+	0.675 kg
N	+	0.423 kg
Prc	+	100 %

see
 Configuring Printouts

Checkweighing Application ↵

With the Checkweighing application, you can check whether the sample on the weighing platform matches a target value or lies within a given tolerance range. Checkweighing also makes it easy to fill sample materials to a specified target weight.

Characteristics

- Enter the nominal or target weight (set point) and the tolerance range delimiters either using the keypad or by saving the weight value of a load on the platform.
- Enter the tolerance limits as absolute values (Target, Min and Max) or via the target value as percentage deviation with user-defined percent limits or with relative limits. Configured in the menu under: *APPL 2: CHECK.WG: 4.5.*
- The target value can be taken over as a weighed value from a weighing platform, and the upper and lower tolerance limits are defined as a percentage deviation from the target value (setting code 4.5.2). The deviation percentage can be changed using the [REF] key: 0.1%, 0.2%, 0.5%, 1%, 1.5%, 2%, 3%, 5% or 10%.
- The target value, lower tolerance limit (minimum) and upper tolerance limit (maximum) can be applied as weighed values from the weighing platform.
- Target value and tolerance limits checked during input; values must conform to: upper limit ≥ target ≥ lower limit ≥ 1 digit.
- Checkweighing range: either 30% to 170% of the target, or from 10% to infinity.
- Results are shown on main display on the bar graph, as well as sent to control output ports for further processing.
- Toggle the main display between weight and tolerances limits by pressing the [↵] key. If the weight in the readout is outside the tolerance range, "LL" (too low) or "HH" (too high) is displayed.

- Activate Info mode with the [Info] key
 - Automatic printout configured in Setup under: *APPL 2: CHECK.WG: 4.6.*
 - Automatic taring of container weight. Configured in Setup under: *APPL: A.TARE: 3.7.*
 - Automatic initialization when you switch on the scale with most recently saved application data. Configured in Setup under: *APPL: A.START: 3.8.*
 - You can assign different functions to the [CF] key for deleting applications. When you clear applications, you can delete either the data stored for all applications or just selected data stored for the active application. Configured in Setup under: *APPL: SEL.CF: 3.24.* (Sel. CF function key [CF] in applications)
 - Tare function:
 - 1) If you store a tare (weight value) by pressing the [↵] key, you can later enter a tare value manually. The tare value you enter is added to the stored tare value. Setting: menu code 3.25.1 (factory setting)
 - 2) A tare value entered manually overwrites a stored tare value (weight value). If you enter a tare value manually, a tare value (weight value) stored later overwrites the manually entered value. Setting: menu code 3.25.2 Configured in Setup under: *APPL: TARE.F: 3.25.*
 - Restore factory default settings. Configured in Setup under: *APPL: DEF.APP: 9. 1.*
- Checkweighing entails comparing the current weight value to a defined target value. You can enter the value for this target using the keypad, or by saving the weight value indicated. You can also define upper and lower tolerance limits based on this target. You can do this by:
- Entering absolute values using the keypad or placing the desired amount of weight on the platform and saving the value, or

- by entering each value as a percentage of the target weight

The initialization data remains valid until deleted by pressing the [CF] key or until overwritten by a new value. They remain saved after the scale is switched off.

Preparation

- Turn scale on: Press the [ON] key
- While all segments are lit, press the [↵] key
- Select Setup: Press the [Fn] key repeatedly until *SETUP* is displayed
- Open the Setup menu: Press the [↵] key
- Select the Checkweighing application: Press the [Fn] key repeatedly and confirm with the [↵] key

Application parameters: Checkweighing

4.2.	Checkweighing range
4.2.1*	30 to 170%
4.2.2	10% to infinity
4.3.	Control output for SET as:
4.3.1*	Output "SET"
4.3.2	Ready to operate
4.4.	Activation of outputs
4.4.1	Off
4.4.2	Always on
4.4.3	On at stability
4.4.4*	On within checkweighing range
4.4.5	On at stability within checkweighing range
4.5.	Parameter input
4.5.1	Min, max, target value, absolute values
4.5.2*	Only target value with percent limits
4.5.3	Target value with free percent limits
4.5.4	Target value; min, max values as relative weights to target value
4.6.	Automatic printing
4.6.1*	Off
4.6.2	On
4.6.3	Only values within tolerance
4.6.4	Only values outside tolerance
4.7.	Checkweighing toward zero
4.7.1*	Off
4.7.2	On

* = Factory setting

- Save the settings with the [↵] key and exit Setup: Press the [↵] key several times.

Minimum Load

The minimum load required for automatic taring of the container weight on the platform (first weight), or for automatic printout of results, is configured in Setup under: *APPL: M.WEIGH: 3.5.*

You can choose from the following 10 levels for this setting:

- 1 digit (no minimum load)
- 2 digits
- 5 digits
- 10 digits
- 20 digits
- 50 digits
- 100 digits
- 200 digits
- 500 digits
- 1000 digits

The "digits" here refer to the scale intervals in the connected weighing platform. If the interval of the connected platform is 1 g, for example, and 1000 digits are required, you must place at least 1000 g (= 1000 intervals) on the weighing platform to activate autotaring or autoprint.

Display

The result of a measurement is shown either as a weight value or in relation to the target.

- **Weight display**
The measured value line always shows the weight value, even if it lies outside the tolerance range.

The bar graph is displayed with symbols indicating lower limit, target and upper limit. Weights are shown logarithmically up to the lower tolerance limit, and linearly beyond that point.

- **Relation to target value**

As "Weight display" above, with the exception that:

- *LL* appears in the main display if the weight value is less than the lower limit
- *HH* is shown on the main display if the weight value is higher than the upper tolerance limit

Digital I/O Interface

The Checkweighing application supports the digital input/output interface.

There are 4 control lines, or outputs, which are activated as follows (see also the diagram below):

- Lighter
- Equal
- Heavier
- Set

In Setup menu:

APPL 2:

CHECK.WG: 4.4.

you can define whether these control ports are

- off
- always on
- activated at stability
- on within the checkweighing range

The "SET" output normally changes its voltage level when the load is near the target weight. Alternatively, you can assign the "Ready for use" function to this port. Configured in Setup under:

APPL 2:

CHECK.WG: 4.3.

This enables you to, for example, connect a simple indicator for weighing or calculation results.

All data output ports have a high voltage level when:

- The application has not been initialized
- The weighing instrument is not at stability and one of the "at stability ..." parameters is selected
- The weight is not within checkweighing range

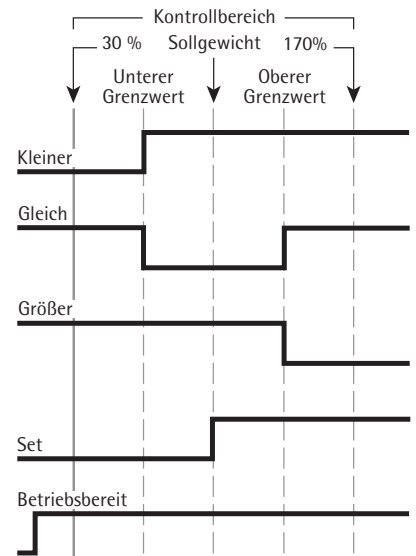

Digital I/O Interface

- "SET" control output: set
- port lines: always on

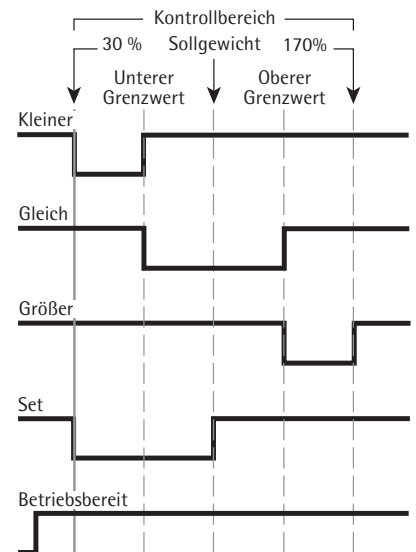

Digital I/O Interface

- "SET" control output: set
- port lines: within the checkweighing range

Output port specifications:

- When not in use, the voltage level is high: >3.7 V/+4 mA
- When activated, the voltage level is low: <0.4 V/-4 mA

⚠ The data outputs are not protected from short circuits.

Example: 1

Checkweighing samples with a target weight of 1250 g and a tolerance range from -10 g to +30 g

Settings (different from the factory settings):

Setup: Application 2: Checkweighing

Setup: Printout, PRTPROT: 7.6, then select the menu line items of your choice

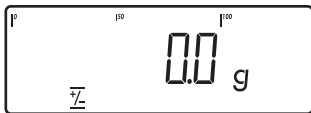

OK

1.) Begin input of target and tolerance values

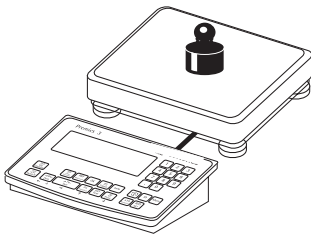

2.) Place a sample with the target weight (in this example, 1250 g) on the platform

OK

3.) Save target value



1 2 4 0

4.) Enter value for lower limit (in this example, 1240 g)



OK

5.) Save value for the lower limit



1 2 8 0

6.) Enter value for the upper limit (in this example, 1280 g)

OK

Save the value for the upper limit



7.) Weigh samples

(=)

8.) Printing results
Note: If automatic printout of results is enabled, you do not need to press the (=) key. The results are printed automatically.

Setp	+	1.250	kg
Min	+	1.240	kg
Max	+	1.280	kg
G#	+	1.256	kg
T	+	0.000	kg
N	+	1.256	kg
Lim	+	0.48	%
W.Diff+		0.006	kg

Target
Minimum
Maximum

Gross weight
Tare weight
Net weight

Percentage of deviation from target*
Absolute deviation from target

* When displayed in relation to target value:
If the weight is lighter than the lower limit, the display shows: LL

If the weight is heavier than the upper limit, the display shows: HH

Checkweighing Toward Zero Application

Example: 2

Checkweighing samples with a target weight of 1250 g and a tolerance range from -10 g to +30 g

Settings (different from the factory settings):

Setup: Application 2: Checkweighing toward zero (parameter 4. 7. 2)

Setup: Printout, PRTPROT 7.6, then select the menu line items of your choice



1 2 8 0

6.) Enter value for the upper limit (in this example, 1280 g)

OK

Save the value for the upper limit

OK

1.) Begin input of target and tolerance values



7.) Weigh samples



8.) Printing results
Note: If automatic printout of results is enabled, you do not need to press the  key. The results are printed automatically.

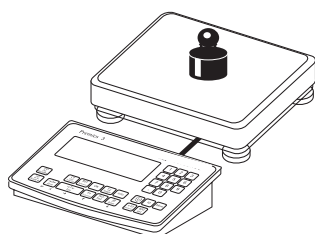

2.) Place a sample with the target weight (in this example, 1250 g) on the platform

Setp + 1.250 kg
Min + 1.240 kg
Max + 1.280 kg

Target
Minimum
Maximum

OK

3.) Save target value



G# + 1.256 kg
T + 0.000 kg
N + 1.256 kg

Gross weight
Tare weight
Net weight

1 2 4 0

4.) Enter value for lower limit (in this example, 1240 g)



Lim + 0.48 %

Percentage of deviation from target*

W.Diff+ 0.006 kg

Absolute deviation from target

* When displayed in relation to target value:
If the weight is lighter than the lower limit, the display shows: LL

OK

5.) Save value for the lower limit





If the weight is heavier than the upper limit, the display shows: HH



Classification Application



With the Classification application, you can determine whether the weight of a given sample lies within the limits of a defined weight class.

Characteristics

- Classification with 3 or 5 weight classes. Configured in Setup under:
APPL 2:
CLASS: 4.8.
- Enter the upper limits of weight classes using the keypad or by saving weight values from a load on the platform
- Enter the upper limits of weight classes as absolute values or as a percentage of deviation from the upper limit of Class 1 Configured in the menu under:
APPL 2:
CLASS: 4.9.
- Activate Info mode with the  key
- Toggle the main display between classification display and weight display by pressing the  key.
- Automatic printout configured in Setup under:
APPL 2:
CLASS: 4. 10.
- Automatic taring of container weight. Configured in Setup under:
APPL: A.TARE: 3. 7.

- Automatic initialization when you switch on the scale with most recently saved application data. Configured in Setup under:
APPL: A.START: 3.8.

You can assign different functions to the  key for deleting applications. When you clear applications, you can delete either the data stored for all applications or just selected data stored for the active application. Configured in Setup under:
APPL: SEL.CF: 3.24.
(Sel. CF function key  in applications)

- Tare function:
1) If you store a tare (weight value) by pressing the  key, you can later enter a tare value manually. The tare value you enter is added to the stored tare value. Setting: menu code 3.25.1 (factory setting)
2) A tare value entered manually overwrites a stored tare value (weight value).
If you enter a tare value manually, a tare value (weight value) stored later overwrites the manually entered value. Setting: menu code 3.25.2
Configured in Setup under:
APPL:  3.25.

- Restore factory default settings. Configured in Setup under:
APPL: DEF.APP: 9. 1.







To use the Classification application, you need to enter the delimiters that separate one class from another.

Limits between the individual weight classes are required for the classification. The lower limit of Class 1 is defined by the preset minimum load. The other classes are configured by defining their upper limits. There are two ways to enter the delimiters for classes 1 through 3 (or 5):

- By saving the weight value indicated: Each upper limit value, with the exception of the highest class, is entered using the keypad or by saving the weight value of a load on the weighing platform.
- By entering a percentage: The upper value of Class 1 is entered using the keypad or by saving the value indicated. Upper limits for the other classes are defined by entering a percentage of deviation from the upper limit of Class 1, using the keypad.
Example: Enter 100 g as the upper limit of Class 1. Then enter 15%.
When working with 3 classes, this yields the following weight classes:
Class 0: up to the minimum load
Class 1: >minimum load - 100 g
Class 2: >100 g - 115 g
Class 3: >115 g - maximum load
When working with 5 classes, this yields the following weight classes:
Class 0: up to the minimum load
Class 1: >minimum load - 100 g
Class 2: >100 g - 115 g
Class 3: >115 g - 130 g
Class 4: >130 g - 145 g
Class 5: >145 g - maximum load

The initialization data remains valid until deleted by pressing the  key or until overwritten by a new value. They remain saved after the scale is switched off.



Preparation

- Turn scale on: Press the  key
- While all segments are lit, press the  key
- Select Setup: Press the  key repeatedly until *APPL* is displayed
- Confirm *APPL*: Press the  key
- Select the Classification application: Press the  key repeatedly and confirm with the  key

Classification Application Parameters

3.6.	Minimum Load for Initialization and Defining the Class 1 Lower Limit
3.6.1*	1 digit
3.6.2	2 digits
3.6.3	5 digits
3.6.4	10 digits
3.6.5	20 digits
3.6.6	50 digits
3.6.7	100 digits
3.6.8	200 digits
3.6.9	500 digits
3.6.10	1000 digits
4.3.	Control output for SET as:
4.3.1*	Output "SET"
4.3.2	Process control systems ready to operate
4.7.	Activation of outputs
4.7.1	Off
4.7.2	Always on
4.7.3*	On at stability
4.8.	Number of classes
4.8.1*	3 classes
4.8.2	5 classes
4.9.	Parameter input
4.9.1*	Weight values
4.9.2	Percentage values
4.10.	Automatic printing
4.10.1*	Off
4.10.2	On

* = Factory setting

- Save the settings with the  key and exit Setup: Press the  key several times.

Minimum Load

The minimum load for the first class is configured in Setup under:
CLASS: 3.6.

Once the limit is exceeded by the load, initialization can begin. Once the application is initialized, a weight value below the minimum load is designated Class 0; no class is displayed.

The minimum load required for automatic taring of the container weight on the platform (first weight), or for automatic printout of results, is configured in Setup under:
APPL: M.WEIGH: 3.5.

You can choose from the following 10 levels for this setting:

- 1 digit
- 2 digits
- 5 digits
- 10 digits
- 20 digits
- 50 digits
- 100 digits
- 200 digits
- 500 digits
- 1000 digits

The “digits” here refer to the scale intervals in the connected weighing platform. If the interval of the connected platform is 1 g, for example, and 1000 digits are required, you must place at least 1000 g (=1000 intervals) on the weighing platform for the first class to activate autotaring or autoprnt.

Display

The result of a given measurement is shown as either a weight value or a class number.

- **Weight display:**
 The current weight is shown in the measured value line and the current class in the text line.
- **Display of classes:**
 The current class is shown in the measured value line, and the current weight in the text line.

Digital I/O Interface

The Classification application supports the digital input/output-interface. There are 4 control lines, or outputs, which are activated as follows (see also the diagram below):

- With 3 classes:
 - Class 1
 - Class 2
 - Class 3
 - Set
- With five classes:
 - Classes 1/2
 - Classes 2/3/4
 - Classes 4/5
 - Set

In Setup menu:

APPL 2:
CLASS: 4.7.
 you can define whether these control ports are

- off
- always on
- activated at stability

The “SET” output normally changes its voltage level when the current weight exceeds the minimum load. Alternatively, you can assign the “Ready for use” function to this port. Configured in Setup under:
APPL 2:
CLASS: 4.3.

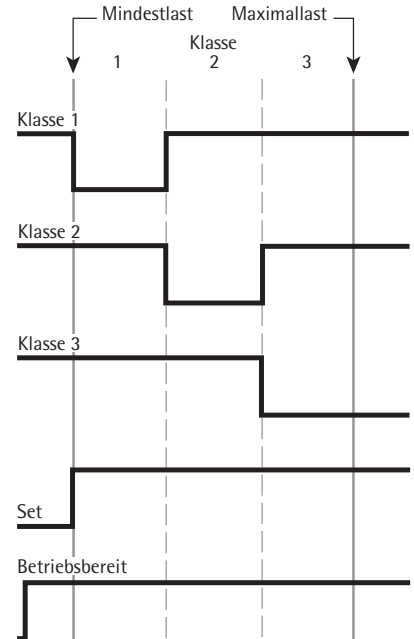

Digital I/O Interface
 Control lines when working with 3 classes

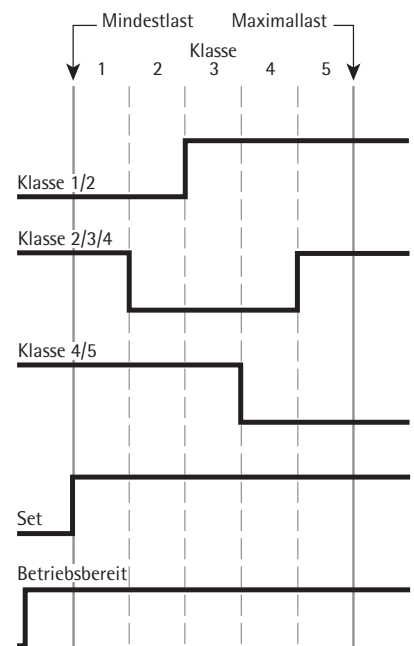

Digital I/O Interface
 Control lines when working with 5 classes

Example:
 Defining three classes.
 Settings (different from the factory settings):
 Setup: Application 2: Classification
 Setup: Printout, PRTPROT 7.6, then select the menu line items of your choice

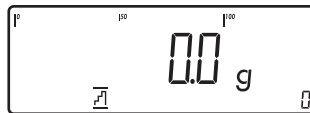
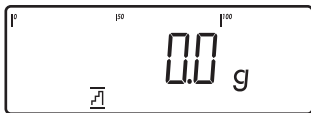

OK

1.) Begin input of class delimiters

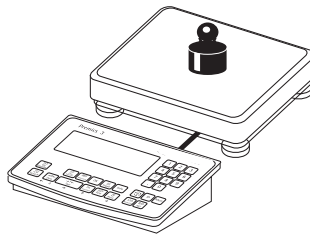

6.) Place the sample on the weighing platform

1 1 0

2.) Enter the upper limit for Class 1 using the keypad (in this example, 110 g)

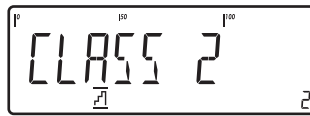

Read the result

OK

3.) Save the upper limit for Class 1



7.) Printing results
 Note: If automatic printout of results is enabled, you do not need to press the  key. The results are printed automatically.



4.) Enter the upper limit for Class 2 using the keypad (in this example, 130 g)

1 3 0

```
Lim1 + 0.110 kg
wRef + 0.130 kg
G#   + 0.118 kg
T    + 0.000 kg
N    + 0.118 g
```

see chapter:
 Configuring Printouts

OK

5.) Save the upper limit for Class 2

```
Class      2
-----
```

Totalizing Application Σ

With the Totalizing application, you can add weight values to the totalizing memory. In addition to weight values, the number of separate values added to memory is also saved (transaction counter).

Characteristics

- Totalize up to 999 individual weights

- Save values automatically:
 - Simultaneous saving of net values and calculated values (if available). Configured in Setup under: *APPL 3: TOTALIZ: 3.16.*
 - Save weight values and calculated values from either Application 1 (for example, Counting, Weighing in Percent) or Application 2 (Check-weighing). Configured in Setup under: *APPL 3: TOTALIZ: 3.22.*
- Current transaction number displayed in the text line (indicating the transactions already added)
- Weighing in up to a defined target, with the totalization memory content + current weight displayed in the text lines
- Save weight values manually or automatically
- Activate Info mode with the **[Info]** key
- Automatic printout when value saved

- Automatic taring of container weight. Configured in Setup under: *APPL: A.TARE: 3.7.*
- Incomplete totalizing routines saved in battery-backed memory after Signum® 3 is switched off. Configured in Setup under: *APPL: A.START: 3.8.*
- You can assign different functions to the **[CF]** key for deleting applications. When you clear applications, you can delete either the data stored for all applications or just selected data stored for the active application. Configured in Setup under: *APPL: SEL.CF: 3.24.* (Sel. CF function key **[CF]** in applications)
- Tare function:
 - 1) If you store a tare (weight value) by pressing the **[T+]** key, you can later enter a tare value manually. The tare value you enter is added to the stored tare value. Setting: menu code 3.25.1 (factory setting)
 - 2) A tare value entered manually overwrites a stored tare value (weight value). If you enter a tare value manually, a tare value (weight value) stored later overwrites the manually entered value. Setting: menu code 3.25.2 Configured in Setup under: *APPL: TARE.F: 3.25.*
- Restore factory default settings. Configured in Setup under: *APPL: DEF.APP: 9.1.*

The Signum has a totalizing memory for totalizing individual net and gross values. Weight values can be saved to the totalizing memory either manually or automatically. In Setup under: *APPL 3: TOTALIZ: 3.16.*

- Save value manually by pressing the **[OK]** key. The value taken from the active platform is added to the value already saved in totalization memory and the transaction counter value is increased by one. When a value is added manually, the program does not check whether the platform has been unloaded since the last time the **[OK]** key was pressed.
- Value saved automatically when the weighing platform is stable and the defined minimum load is exceeded. If the defined minimum load is not exceeded, you can save the item manually by pressing the **[OK]** key. Regardless of these settings, the current value cannot be saved automatically unless the platform is unloaded before the next sample is placed on it. The weighing platform is considered to be unloaded when the load is less than 50% of the minimum load.

The number of items added to memory is displayed in the text line.

Press the **[CF]** key to clear the totalizing memory. A printout is automatically generated.

With 2 weighing platforms connected, you can add values from both platforms to the totalizing memory. The displayed result is accurately calculated in the active weight unit.

Example: When you add 1243 g (determined on a weighing platform with three decimal places) to 1400 g (determined on a platform with 1 decimal place), the display shows 2643 g.

Preparation

- Turn scale on: Press the **(ON)** key
- While all segments are lit, press the **(→T←)** key
- Select Setup: Press the **(Fn)** key repeatedly until *APPL* is displayed
- Confirm *APPL*: Press the **(→T←)** key
- Select the Totalizing application: Press the **(Fn)** key repeatedly and confirm with the **(→T←)** key

Totalizing Application Parameters

— 3.6.	Minimum load for autosave
— 3.6.1*	1 digit
— 3.6.2	2 digits
— 3.6.3	5 digits
— 3.6.4	10 digits
— 3.6.5	20 digits
— 3.6.6	50 digits
— 3.6.7	100 digits
— 3.6.8	200 digits
— 3.6.9	500 digits
— 3.6.10	1000 digits
— 3.16.	Autosave mode
— 3.16.1*	Off
— 3.16.2	On
— 3.17.	Individual/Component printout when saved
— 3.17.1	Automatic printing off
— 3.17.2*	Print the entire standard print configuration every time with the (OK) key
— 3.22.	Source of values for data saved automatically
— 3.22.1*	Application 1
— 3.22.2	Application 2
— 3.23.	Saved value
— 3.23.1*	Net
— 3.23.2	Calculated
— 3.23.3	Net and Calculated

* = Factory setting

- Save the settings with the **(→T←)** key and exit Setup: Press the **(→0←)** key several times.

Minimum Load

The minimum load required for automatic taring of the container weight on the platform (first weight) is configured in Setup under:
APPL: M.WEIGH: 3.5.

The minimum amount that a component must weigh before it can be saved in totalizing memory is configured in Setup under:
*APPL 3:
TOTALIZ: 3.6.*

You can choose from the following 10 levels for this setting:

- 1 digit
- 2 digits
- 5 digits
- 10 digits
- 20 digits
- 50 digits
- 100 digits
- 200 digits
- 500 digits
- 1000 digits

The “digits” here refer to the scale intervals in the connected weighing platform. If the interval of the connected platform is 1 g, for example, and 1000 digits are required, you must place at least 1000 g (= 1000 intervals) on the weighing platform for autotaring (only with the “Autotare first weight” option selected).

Printout

In Setup menu:

*APPL 3:
TOTALIZ: 3.17.*

You can configure whether a printout is generated manually by pressing the **(F)** key or automatically when a weight value is stored in the totalizing memory.

If you select the *3.17.1* menu item, printouts can only be generated manually by pressing the **(F)** key (single printout).

If the *3.17.2* menu item is selected (Print one component), the component record is printed.

The total data record is printed when you clear the totalizing memory (by pressing the **(CF)** key).

Example:

Totalizing weight values.

Settings (different from the factory settings):

Setup: Application 3: Totalizing

Setup: Printout, PRTPROT 7.6

Setup: Device Parameters: Printout: Printer 1: Select "Component log:

Auto printout", then select the menu line items of your choice PRT PROT: 7.7.

Setup: Printout: Printer 1: Select "Total data record:

Printout as per CF key," then select the menu line items of your choice PRTPROT: 7.8.

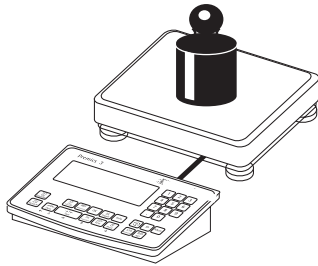

1.) Place the first weight on the weighing platform

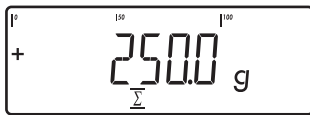

Weight value is displayed

OK

2.) Store first weight value in totalizing memory

G#	+	0.250	kg
T	+	0.000	kg
N	+	0.250	kg
n		1	

Component weight is printed automatically (configured component log)

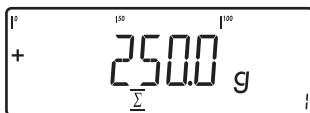

The transaction counter value is increased by one.

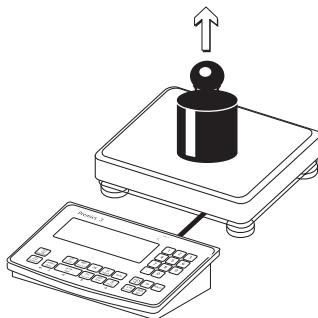

3.) Remove the first weight from the weighing platform

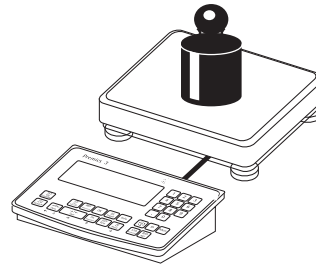

4.) Place the second weight on the weighing platform

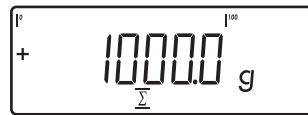

Weight value is displayed

OK

5.) Store second weight value in totalizing memory

G#	+	1.346	kg
T	+	0.346	kg
N	+	1.000	kg
n		2	

Component weight is printed automatically (configured component log)

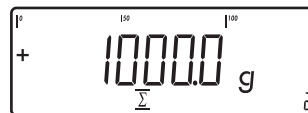

The transaction counter value is increased to two

F2

6.) Toggle display between individual value and total

CF

7.) End totalizing



*G	+	1.346	g
*N	+	1.250	g
n		2	

Component weight is printed automatically (configured component log).

Net-total Formulation Application

With this application, you can weigh in different components up to a defined total. Each component is saved in the net-total memory.







Characteristics

- Weigh in up to 999 components in series
- Net total formulation cannot be combined with a level 1 or level 2 application
- Current component number displayed in the text lines (indicating the component to be added)
- Toggle the display from "component mode" to "additive mode" by pressing the  key.
 - Component mode: Display the weight of the component currently on the platform (for 1 second after it is saved; then the platform is tared)
 - Additive mode: Display the weight of all components on the platform (after it is saved, the net weight of the last component added is displayed briefly)
- Activate Info mode with the  key
- Automatic component printout when it is saved. Configured in Setup under:
APPL 3:
NET TOT: 3. 17.



If the 3. 17.2 menu item is selected, the entire component record is printed. If the 3. 17.3 menu item is selected, the following items are generated only once for the first component:
Blank line, date, time, ID1 through ID4, header lines 1 and 2. For subsequent components, each "component" item ("Comp xx") is followed by a blank line.

- Automatic taring of container weight. Configured in Setup under:
APPL: A.TARE: 3. 7.
- Restore factory default settings. Configured in Setup under:
APPL: DEF.APP: 9. 1.



Preparation

- Turn scale on: Press the  key
- While all segments are lit, press the  key
- Select Setup: Press the  key repeatedly until *APPL* is displayed
- Confirm *APPL*: Press the  key
- Selecting the Net-total Formulation Application:
Press the  key repeatedly and confirm with the  key

Net-total Formulation Application Parameters

— 3.6.	Minimum load for autosave
— 3.6.1*	1 digit
— 3.6.2	2 digits
— 3.6.3	5 digits
— 3.6.4	10 digits
— 3.6.5	20 digits
— 3.6.6	50 digits
— 3.6.7	100 digits
— 3.6.8	200 digits
— 3.6.9	500 digits
— 3.6.10	1000 digits
— 3.17.	Individual/Component printout when saved
— 3.17.1	Automatic printing off
— 3.17.2*	Print the entire standard print configuration every time with the  key
— 3.17.3*	Print the entire standard print configuration once with the  key

* = Factory setting

- Save the settings with the  key and exit Setup: Press the  key several times.

Minimum Load

The minimum amount that a component must weigh before it can be saved in net-total memory is configured in Setup under: *APPL 3 NET TOT: 3.6.*

Once the limit is exceeded by the load, the value can be saved. If the load on platform is too light, the following will occur when you try to save a value:

- Error code *INF 29* appears,
- The weight is not saved

The minimum load required for automatic taring of the container weight on the platform (first weight) is configured in Setup under: *APPL: M.WEIGH: 3.5.*

You can choose from the following 10 levels for this setting:

- 1 digit
- 2 digits
- 5 digits
- 10 digits
- 20 digits
- 50 digits
- 100 digits
- 200 digits
- 500 digits
- 1000 digits

The “digits” here refer to the scale intervals in the connected weighing platform. If the interval of the connected platform is 1 g, for example, and 1000 digits are required, you must place at least 1000 g (= 1000 intervals) on the weighing platform for saving.

Example:

Weighing in 3 components of a formulation recipe.

Settings (different from the factory settings):

Setup: Application 3: Net total

Setup: Printout, PRT PROT: 7.7. Printer 1:

Select "Component log: Auto printout", then select the menu line items of your choice

Setup: Printout; PRT PROT: 7.8 Printer 1:

Select "Total data record: Printout as per CF key," then select the menu line items of your choice

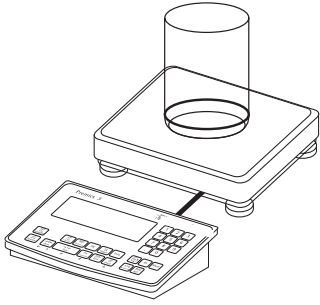

1.) Place empty container on the platform



2.) Tare the scale.

Note: If the automatic tare function is enabled, you do not need to press the  key to tare the platform; the tare weight is saved automatically when you place the container on the platform

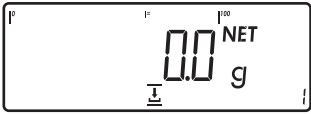

Prompt to fill and save the first component is shown

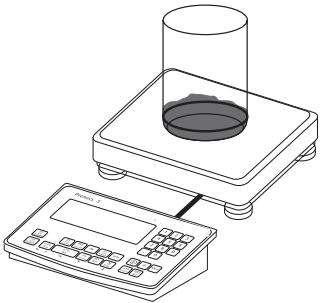

3.) Add the first component to the container (in this example: 1100 g)

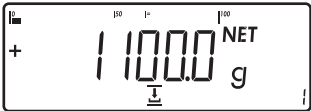

The weight of the first component is displayed



4.) Save the first component weight

Comp001+ 1.100 kg

The component record is printed automatically

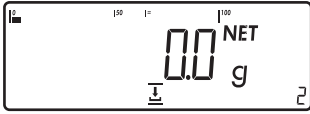

The weighing platform is tared and the component counter value is increased by one. Prompt to fill and save the second component is shown

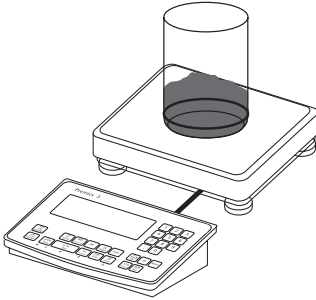

5.) Add the second component to the container (in this example: 525 g)



The weight of the second component is displayed



Cmp002+ 0.525 kg

6.) Save the second component weight

The component record is printed automatically



The weighing platform is tared and the component counter value is increased by one. Prompt to fill and save the third component is shown



7.) Toggle to the "additive mode", to display the total weight of all components



The value displayed equals the weight of components added up to now plus the current weight on the platform.

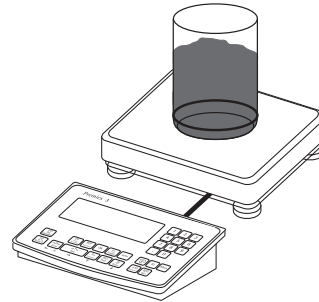

8.) Add the third component to the container until the desired target is reached (in this example: 2000 g)

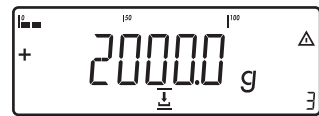

The total weight is displayed



Cmp003+ 0.375 kg

9.) Save the third component weight

The component record is printed automatically

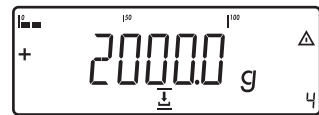

The component counter value is increased by one. Prompt to fill and save the fourth component is shown



10.) End weighing-in operation

n + 3
Tot.cp+ 2.000 kg
Cont.T+ 0.296 kg

Results are printed automatically (configured total data record)

Number of components
Content of component memory
Content of tare memory (container weight)

Example: "Portioning" (counting, checkweighing with totalizing)

Settings (different from the factory settings):

Setup: Application parameters: Application 1: Counting (COUNT)

Setup: Application parameters: Application 2: Checkweighing (CHECK.WG)

Setup: Application parameters: Application 3: Totalizing: Saved value: Net + Calculated (3.23.3)

Setup: Application parameters: Application 3: Totalizing: Autosave: On (3.16.2)

Setup: Application parameters: Application 3: Totalizing: Source of data: Application 2 (3.22.2)

Setup: Printout: PRT PROT 7.8. Printer 1:

"Total: Print printout when FN pressed," then select the menu line items of your choice (X.XX.X)



1.) Switch on the scale and enter settings as above



2.) Delete any data from previous operation

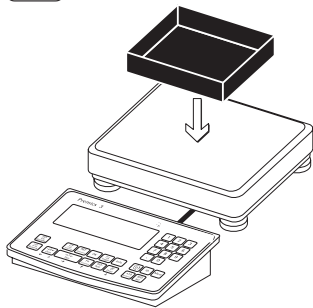

3.) Place empty container on the platform.



4.) Tare the scale.

Note: If the automatic tare function is enabled, you do not need to press the  key to tare the platform; the tare weight is saved automatically when you place the container on the platform

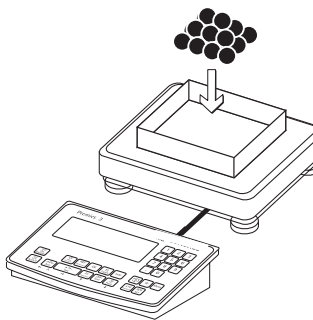
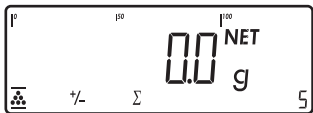

5.) Place a number of parts in the container for the reference quantity (in this example, 10 pcs)



6.) Start calculation of reference sample weight

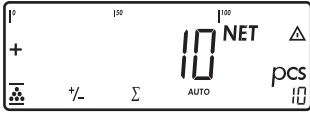

If the weight is too light, an error code is shown in the main display *INF 29*

Reduce the minimum load setting or increase the reference sample quantity setting and the number of parts in the container

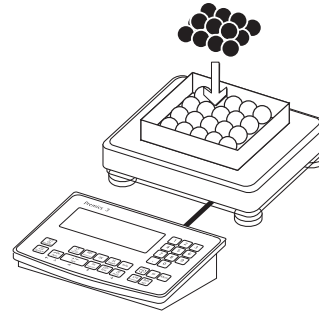

11.) Add desired number of pieces



7.) Toggle to Checkweighing

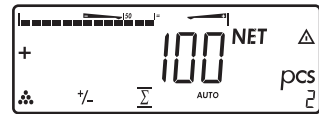
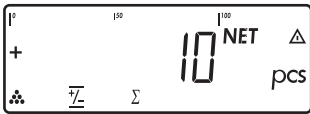

The number of pieces is saved



8.) Initialize Checkweighing

12.) Unload the scale:
Remove the samples

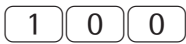

9.) Enter target value, minimum and maximum (in this example, target 100 pieces, minimum 100 pieces, maximum 102 pieces)

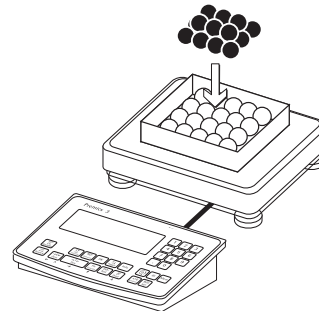

13.) Perform further counting operations as desired

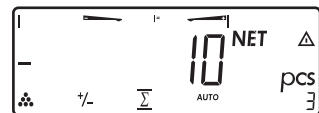
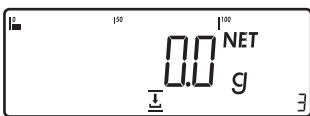
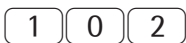
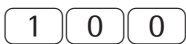

14.) Toggle display from individual value to total



15.) End the portioning options and print the final evaluation



10.) Toggle to Totalizing

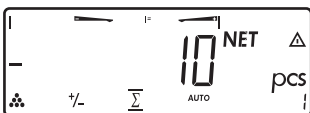

```

-----
nRef +      10 pcs
wRef + 0.001000 kg
Setp +      100 pcs
Min  +      100 pcs
Max  +      102 pcs

n      6
*N   +      0.600 kg
Total +      600 pcs
-----
    
```

Configured printout: Total

Configuring Printouts

Purpose

You can configure individual printout formats for each application. Using the total data record for Totalizing and Net total formulation applications, you can define which parameters are printed using the **[CF]** key.

In the "Print parameters" Setup menu, single, component and total data records can be configured, which contain the available print items for the respective applications. This should be carried out after setting the applications since some data in the printout is application-dependent.

Characteristics

- Quantity and extent of printout lists: 6 lists each with a max. length of 30 print items
 - Single printout Printer 1
 - Component printout Printer 1
 - Total data printout Printer 1
 - Single printout Printer 2
 - Component printout Printer 2
 - Total data printout Printer 2
- Single, component and total data records can be configured separately
- Print single printout: **[F7]** key
Auto printout of application when Setup menu is activated:
 - Animal weighing (averaging)
 - Checkweighing
 - Classification
- Print component printout: Totalizing/Net-total formulation with the **[OK]** key (Setup: Application 3: Totalizing: Printout: Component printout)
- Print total data printout: For selected application Totalizing/Net-total formulation with **[CF]** key
- When switching to another application in Setup, only the application-dependent printout lists are deleted. The other printout lists remain saved.
- Print items can be deleted individually: Press and hold the **[⇨0⇩]** key
- Print items "Form Feed" for record footer: Move to the next label start for printer type: YDP04IS, setting "Label, manual form feed"
- ISO/GLP/GMP-compliant printout: The Setup menu configuration under "ISO/GMP-compliant printout" is also active for configured printouts.

Preparation

- Turn scale on: Press the **[I/O]** key
- While all segments are lit, press the **[⇨T⇩]** key
- Select Setup menu: Press the **[Fn]** key repeatedly until **SETUP** is displayed
- Select "Config. printout:" Press the **[⇨T⇩]** key
- Press the **[Fn]** key repeatedly until **PRTPRT** is displayed
- Press the **[⇨T⇩]** key

PRTPRT
(see page 35 for a detailed menu list)

7	7.4	Header and ID header input
	7.5	Interface quantity
	7.6	Standard interface
	7.7	Component interface
	7.8	Result interface
	7.13	ISO/GMP
	7.14	Date without time
	7.15	Automatic printout after stability
	7.16	Flex print
	7.17	Decimal separator
9	9.1	Factory settings

- The rows of the printout list can be called up and activated individually. Example: see under Configuration, menu item 7.6
- The print selection set as active appears with the left selection bar on the display, e.g. gross, tare, net.
- Extend printout, press the **[⇨T⇩]** key, the selection bar now appears on the right of the display.
- Select print items using the **[Fn]** key
- Apply the desired print items by pressing the **[⇨T⇩]** key
- Press the **[⇨0⇩]** key to change the print selection set as active. The selection bar appears on the left. The required print item is set as active and appears in the printout.

- Print items can be deleted individually from the active printout selection: Press and hold the **[⇨0⇩]** key

- Save the settings with the **[⇨T⇩]** key and exit Setup: Press the **[⇨0⇩]** key several times.

Additional Functions

Printing the "Selection" and "List" Settings

- **LIST**: Output of the current printout list
SELECT: Print currently selectable items
- When the select bar is on **LIST** or **SELECT**: Press the **[F7]** key

> Printout (example)

```

Indiv.Prt
  List
=====
Net (N)
Gross (G#)
Tare
Tare (T2/PT2)
Piece count
=====
etc.
    
```



Example:
Standard printout for data output from the Counting application

Settings (different from the factory settings):
Applications: Application 1: Counting
Then access Setup: Printout: Printer 1: "Individual: print by pressing (Fn)"

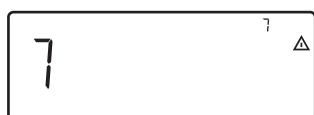
- Select Setup menu: Press the (Fn) key repeatedly until *SETUP* is displayed
- Select "Config. printout:" Press the (→T←) key
- Press the (Fn) key repeatedly until *PRTPROT* is displayed
- Press the (→T←) key

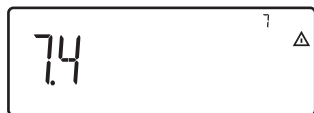

1.) Press the (→T←) key until 7.4 appears in the display



2.) Press the (Fn) key until 7.6 appears in the display

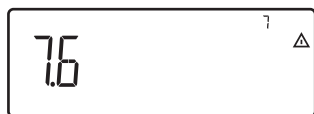

3.) Press the (→T←) key to display the list of print items (active print selection)



4.) Press the (→T←) key to go to the selection list



First printout list of selection list



5.) Press the (→T←) key to add the displayed print item from the selection list to the list of print items.

Or



6.) Press the (Fn) key to go to the possible print items in the selection list.
Selection of available print items, see *SETUP: PRTPROT* (Settings)



7.) Press the (Fn) key until ----- appears in the display

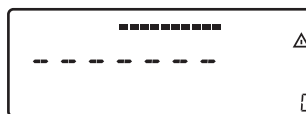

8.) Press the (→T←) key to apply the selection

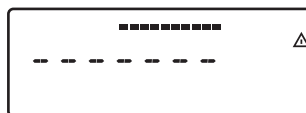

9.) Press the (Fn) key until *REF.-GEW* appears in the display



10.) Press the (→T←) key to apply the selection

11.) Selecting additional printout items: see previous steps

12.) To complete the selection of print items, press the (→0←) key until *APPL* appears in the display



13.) Press and hold the (→T←) key (2-3 sec) to switch to weighing mode

14.) Carry out weighing and then print



15.) Press the (Fn) key to print the results

wRef + 0.4000 g

Printout example

Product Data Memory

Purpose

The product data memory stores initialization data and user data (product and tare values).

Characteristics

- The product data memory has 100 memory cells for product or tare values.
 - For example, you can store 80 sets of application data and 20 tare values.
- Each memory cell is uniquely identified by a number up to three digits.
- The product data memory can be used with the following applications:
Application level 1
 - *WEIGH.*
 - *COUNT.*
 - *NEUTR.M*
 - *ANIM.WG*
 - *PERC.WG*
- Application level 2
 - *CHECK.WG*
 - *CLASS.*
- Data records can be created, overwritten and individually deleted
- Data remains stored when the scale is switched off

Functions

Saving product data (in this example, in the Counting application):

- Initialize the application.
- Enter a memory number and press and hold the **Mem** key (min. 2 seconds).

Saving preset tare values:

- Allocate preset tare memory.
- Enter a memory number and press and hold the **Tare** key (min. 2 seconds).

Activation of saved product or tare values:

- Enter a memory number and press the **Mem** key.

Displaying information for a specific product or tare value:

- Enter a memory number and press the **Info** key.
- Use the **Fn** key to select between *WREF* (average piece weight) and *NREF* (quantity).
- Use the **→T←** key to scroll the displayed value to the right.
- Activate the displayed memory by pressing the **Mem** key.
- Delete the displayed memory by pressing and holding the **CF** key (min. 2 seconds).
- Exit the mode by pressing the **CF** key.

Displaying information for all product or tare memories:

- Press the **Mem** key to display the first memory number.
- Press the **Fn** key to scroll through in lexical order (e.g. 1, 3, 333, 4, ...).
- Press the **Mem** key to activate the selected memory number.
- Display the saved product values using the **Info** key.
- Press and hold the **CF** key (at least for 2 seconds) to delete the selected memory number.
- Exit the mode by pressing the **CF** key.

Deleting a specific memory number:

- Enter a memory number and press and hold the **CF** key.

Example:

Using the Counting application with a stored average piece weight.
Settings (different from the factory settings):
Setup: Application parameters:
Application: Counting (*COUNT.*)

Saving the average piece weight:

- Initialize the application.
- Determine the average piece weight using one of the methods described above.
- Enter the memory cell number using the keypad, and press and hold the **Mem** key (min. 2 Seconds).

Loading the average piece weight or reference sample quantity:

- Enter the memory cell number and press the **Info** key.
- Use the **Fn** key to select between *WREF* (average piece weight) and *NREF* (quantity).
- Use the **→T←** key to scroll the displayed value to the right.

- Activate the displayed memory by pressing the **Mem** key.

- Delete the displayed memory by pressing and holding the **CF** key (min. 2 seconds).
- Exit the mode by pressing the **CF** key.

Overwriting data in memory cell:

- To save a new average piece weight in a memory cell already in use, enter the desired memory cell number using the keypad and press and hold the **Mem** key (min. 2 seconds). The previous average piece weight is overwritten.

Deleting an average piece weight:

- Enter the memory cell number of the average piece weight to be overwritten and press the **Info** key.
- Delete the displayed value by pressing and holding the **CF** key (min. 2 seconds).

Data Interface

Purpose

Signum -3-Ex scales have an intrinsically safe data interface which can be connected to a computer (or any other peripheral device) using a barrier (e.g. YDI05-Z). You can use a computer to change, start and/or monitor functions of weighing instruments and application programs. The data interface is also used for the control lines of the "Checkweighing" application program.

Warning when using pre-wired connecting cables:

Cables purchased from other manufacturers often have pin assignments that are not permissible for use with Minebea Intec devices. Be sure to check the pin assignments against the chart in this manual before connecting the cable, and disconnect any lines identified differently from those specified by Minebea Intec. Failure to do so may cause malfunction, damage or even completely ruin your weighing system and/or peripheral device(s).

Features

Type of interface:	Serial interface
Interface operating mode:	full duplex, (RS485 half duplex)
Level:	RS232, RS485, RS422
Transmission rate:	150, 300, 600, 1200, 2400, 4800, 9600 and 19200 baud
Parity:	Space, uneven, even, without
Character transmission:	Start bit, 7-bit ASCII, parity, 1 or 2 stop bits
Handshake:	For 2-wire interface: Software (XON/XOFF) For 4-wire interface: Hardware (CTS/DTR)
Operating mode:	SBI, XBPI*, SMA, various printers
Network address**:	0, 1, 2, ..., 30, 31
SBI output format:	16 or 22 characters
Printout of application data:	Output of a configurable printout
* XBPI communication mode:	Always 9600 baud, 8-bit, odd parity, 1 stop bit
** Network address is only relevant for the XBPI mode	

Factory Setting of the Parameters:

Depends on the device configured; for example: "SBI" setting

Transmission rate:	1200 baud
Parity:	Odd
Stop bits:	1 stop bit
Handshake:	Hardware handshake, 1 character after CTS
Operating mode:	SBI
Network address:	0
Print (manual/automatic)	Manual after stability
Cancel automatic printing:	Not possible
Time-dependent automatic printout:	After 1 display update
Tare after individual printout:	Off
Line format:	For other apps./GLP (22 characters)

Pin Assignment Chart RS232

COM1 female connectors:
Round socket with screw lock hardware
for model SIWXSDC / SIWXSBB

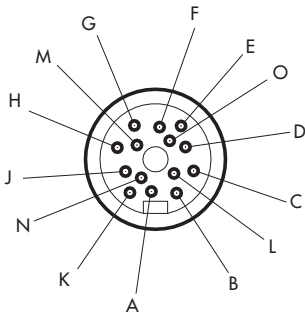

Front view

COM1 pin assignments
Round plug, 14-pin

- Pin A: Clear to send (CTS)
- Pin B: -
- Pin C: -
- Pin D: Control Output: "set"
- Pin E: Control output: "equal"
- Pin F: Control output: "lighter"
- Pin G: Control output: "heavier"
- Pin H: -
- Pin J: Data input (RxD)
- Pin K: Data output (TxD)
- Pin L: -
- Pin M: Signal GND
- Pin N: Data terminal ready (DTR)
- Pin O: Universal switch input

Pin Assignment Chart RS422

COM1 female connectors:
Round socket with screw lock hardware
for model SIWXSDC / SIWXSBB

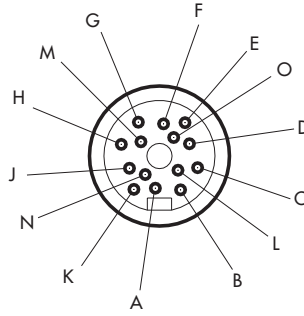

Front view

COM1 pin assignments
Round plug, 14-pin

- Pin A: Signal GND
- Pin B: Clear to send (DTR-)
- Pin C: Clear to send (DTR+)
- Pin D: -
- Pin E: Data terminal ready (CTS-)
- Pin F: Data terminal ready (CTS+)
- Pin G: Data output (RxD+)
- Pin H: -
- Pin J: Signal GND
- Pin K: Data input (TxD-)
- Pin L: -
- Pin M: Data output (RxD-)
- Pin N: Data input (TxD+)
- Pin O: -

Pin Assignment Chart RS485

COM1 female connectors:
Round socket with screw lock hardware
for model SIWXSDC / SIWXSBB

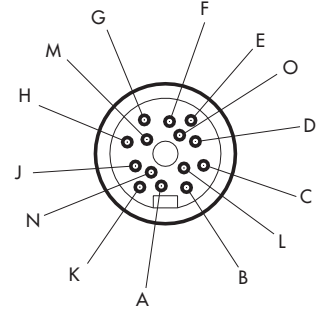

Front view

COM1 pin assignments
Round plug, 14-pin

- Pin A: -
- Pin B: -
- Pin C: -
- Pin D: Control Output: "set"
- Pin E: Control output: "equal"
- Pin F: Control output: "lighter"
- Pin G: Control output: "heavier"
- Pin H: -
- Pin J: Data input (RxD-TxD-P)
- Pin K: Data output (RxD-TxD-N)
- Pin L: -
- Pin M: Signal GND
- Pin N: -
- Pin O: Universal switch input

Attention: Verification of Intrinsic Safety. Drawing 36953-750-60 must be observed!

Configuring the Data Interface as a COM Port (*DATPROT*, when com1 is not RS485)

You can configure the interface as a COM port in either COM1 or UniCOM, "Data Protocol" (*DATPROT*) menu item.

SBI communication

This is a simple ASCII interface.

Data output is configured under menu items 6.1 and 6.3:

- Manual output of displayed value with or without stability (menu items 6.1.1 and 6.1.2)
- Automatic output of displayed value with or without stability (menu items 6.1.4 and 6.1.5) at intervals defined by display updates. The number of display intervals is set in menu item 6.3.
- Output of a configurable printout. Output is linked to the "Printouts" menu item (*PRTPROT*), (see page 81 "Configuring Printouts")

If you do not activate and configure a user-definable data record, the printout simply contains the current value displayed on the display and control unit (weight with unit, calculated value, alphanumeric display).

SMA communication

Standardized communications protocol of the Scale Manufacturers Association

Data Input Format (Commands)

You can connect a computer to your scale to send commands controlling weighing instrument functions and applications via the interface port.

All commands use the same data input format. They start with the ESC character (ASCII 27) and end with a carriage return (CR; ASCII 13) and a line feed (LF; ASCII 10). The total length of a command is anywhere from 4 characters (1 command character between the start and end described above) to a max. of 7 characters (4 command characters).

The commands listed in the following table must each be supplemented with ESC ... CR LF.

Example: The command character for output is "P" ("output to Port"). To trigger this command, send the string: "ESC P CR LF".

Command	Meaning
K	Weighing mode 1
L	Weighing mode 2
M	Weighing mode 3
N	Weighing mode 4
O	Lock keys
P	Send display value to data interface
R	Release keys
T	Taring and zeroing (Combined Tare function)
f3_	Zero (see also the "kZE_" command)
f4_	Tare without zeroing (see also "kT_" command)
kF1_	F1: Trigger (Fn) key function
kF2_	F2: Trigger (CF) key function
kF3_	F3: Trigger (REF) key function
kF4_	F4: Trigger (OK) key function
kF5_	F5: Trigger (↺) key function
kF6_	F6: Trigger (9) key function
kF7_	(ID) key *
kF8_	(D) key *
kF9_	(Mem) key
kF10_	(ISO-Test) key
kF11_	(x10) key
kF12_	(B/G) key
kCF_	CF: Trigger (CF) key function
kP_	Trigger (E) key function Print at printer interface
kT_	Trigger (T) key function (Tare)

Command Meaning

kNW_	Trigger (AA) key function (toggle the weighing platform)**
kZE_	Trigger (→0←) key function (Zero)
a6_	Write the next stable weighing value to the alibi memory
a7_	Write a stable weighing value previously requested by ESC to the alibi memory when SB output mode 6.1.8 is active. The transaction number is returned. Only effective with setting Protocol printout without stability (6.1.8)
x1_	Output model designation of active scale Example: "SIWXSDCP-3-16-H«"
x2_	Output serial number of active scale, Example: "0012345678"
x3_	Output software version of active scale, Example: "00-20-04"
x4_	Output software version of indicator, example: "00-37-2B"
x9_	Output serial number of indicator
x10_	Output model of indicator, example: "SIWXSDCP-3-35-H"
x12_	Output Max load of the current scale
x13_	Output Min load of the current scale
x14_	Output Max load of the current weighing range of the current scale
x15_	Output Min load of the current weighing range of the current scale
z1_	Input: printout header 1
z2_	Input: printout header 2
txx...x_	xx...x: Input text for main display. Length of corresponding input
z3xxx_...z6xxx	Input: ID 1-6

The ASCII code for the "underline" character ("_") is 95 decimal.

Format for entering printout header lines: "ESC z x a ... a_ CR LF" with x = 1 or 2 and a ... a: 1 to 20 characters for header x, followed by the underline, CR and LF characters.

Data Output Format

Each line in a print job can contain up to 22 characters (up to 20 printable characters plus two control characters). The first 6 characters, called the "data header", identify the subsequent value.

You can suppress the header under menu item 7.2 in the "Printouts" menu; in this case, the print job has up to 16 characters (up to 14 printable characters plus two control characters).

Examples:

```

+      235 pcs      without Header
Qnt +      235 pcs      with Header
    
```

Display segments that are not activated are output as spaces. Values with no decimal point are output without a decimal point.

Data Output Format with 16 Characters (without Data Header)

Normal Operation:

```

Pos.  1 2 3 4 5 6 7 8 9 10 11 12 13 14 15 16
-----
+ * A A A A A A A * E E E CR LF
or - * A A A A A A A * E E E CR LF
or  * * * * * * * * * * * * * CR LF
    
```

- +-: Plus or minus sign
- *: Space
- A: Digit or letter (max. 7 characters plus decimal point)
- E: Unit symbol (1-3 letters followed by 2-0 spaces)
- CR: Carriage return
- LF: Line feed

Special Codes:

```

Pos.  1 2 3 4 5 6 7 8 9 10 11 12 13 14 15 16
-----
* * * * * * - - * * * * * CR LF
or * * * * * * H * * * * * * CR LF
or * * * * * * * H H * * * * * CR LF
or * * * * * * * L * * * * * * CR LF
or * * * * * * * L L * * * * * * CR LF
or * * * * * * * C * * * * * * CR LF
    
```

- *: Space
- : Final readout
- H: Overload
- HH: Overload in checkweighing
- L: Underweight
- LL: Underweight in checkweighing
- C: Adjustment

Error Message:

```

Pos.  1 2 3 4 5 6 7 8 9 10 11 12 13 14 15 16
-----
* * * E r r * * # # * * * * CR LF
or * * * E r r * * # # # * * * * CR LF
    
```

- *: Space
- #: Error code number (2 or 3 digits)

Example (output of weight value of +1255.7 g):

```

Pos.  1 2 3 4 5 6 7 8 9 10 11 12 13 14 15 16
-----
+ * * * 1 2 5 5 . 7 * g * * CR LF
    
```

- Position 1: Plus +, or minus – or space
- Position 2: Space
- Positions 3-10: Weight value with decimal point. leading zeros are output as spaces.
- Position 11: Space
- Positions 12-14: Characters for unit of measure or space
- Position 15: Carriage return
- Position 16: Line feed

Data Output Format with 22 Characters (with Data Header)

Normal Operation:

```

Pos.  1 2 3 4 5 6 7 8 9 10 11 12 13 14 15 16 17 18 19 20 21 22
-----
K K K K K K + * A A A A A A A * E E E CR LF
or K K K K K K - * A A A A A A A * E E E CR LF
or * * * * * * * * * * * * * * * * * * CR LF
    
```

- K: ID code character, right-justified with spaces
- +-: Plus or minus sign
- *: Space
- A: Digit or letter (max. 7 characters plus decimal point)
- E: Unit symbol (1 to 3 letters followed by 2-0 spaces)
- CR: Carriage return
- LF: Line feed

Special Codes:

```

Pos.  1 2 3 4 5 6 7 8 9 10 11 12 13 14 15 16 17 18 19 20 21 22
-----
S t a t * * * * * * * - - * * * * * * CR LF
or S t a t * * * * * * * * H * * * * * * CR LF
or S t a t * * * * * * * * H H * * * * * * CR LF
or S t a t * * * * * * * * L * * * * * * CR LF
or S t a t * * * * * * * * L L * * * * * * CR LF
or S t a t * * * * * * * * C * * * * * * CR LF
    
```

- *: Space
- : Final readout
- H: Overload
- HH: Overload in checkweighing
- L: Underweight
- LL: Underweight in checkweighing
- C: Adjustment

Error Message:

```
Pos. 1 2 3 4 5 6 7 8 9 10 11 12 13 14 15 16 17 18 19 20 21 22
      S t a t * * * * * E r r * * # # * * * * CRLF
or   S t a t * * * * * E r r * # # # * * * * CRLF
```

*: Space
#: Error code number (2 or 3 digits)

ID Code Characters:

Character K	Meaning
G#	Gross value
N	Net value
T	Application tare memory 1
T2	Application tare memory 2
Diff	Difference from adjustment value
Targ.	Exact adjustment weight value
Nom.	Exact adjustment weight for SBI printout
nRef	Reference sample quantity
pRef	Reference percentage
wRef	Reference piece weight
Qnt	Result from Counting (piece count) and Neutral Measurement applications
mDef	Target value for animal weighing
x-Net	Animal weighing results
Setp	Target value for checkweighing
Diff.W.	Absolute deviation (e.g., in kg) in Checkweighing
Lim	Deviation in % in Checkweighing
Max	Upper tolerance for checkw.
Min	Lower tolerance for checkw.
Stat	Status
Classx	Classification
Limx	Class limit
D	Percentage (as loss)
Prc	Percentage (as residue)
Wxx%	Reference percentage weight
Cmpxxx	Component xxx
Cont.T	Contents of the tare memory in Net-total Formulation
S-Comp	Total of initial weighings for Net-total Formulation
PT2	Preset tare
n	Transaction counter
*G	Sum of gross weights in Totalizing
*N	Sum of net weights in Totalizing
Ser.no.	Serial number of the platform or indicator

Example (output of weight value of +1255.7 g):

```
Pos. 1 2 3 4 5 6 7 8 9 10 11 12 13 14 15 16 17 18 19 20 21 22
      G # * * * * * + * * * * 1 2 5 5 . 7 * g * * CRLF
```

Positions 1-6: ID code, right-justified with spaces
Position 7: Plus +, or minus - or space
Position 8: Space
Positions 9-16: Weight value with decimal point. leading zeros are output as spaces.
Position 17: Space
Positions 18-20: Characters for unit of measure or space
Position 21: Carriage return
Position 22: Line feed

△ If the weight value is output with 10-fold increased resolution, this value may not be printed or saved in a weighing instrument operated in legal metrology in SBI operation. In this case, the unit symbol is not included with output.

Configuring the Data Interface as a Printer Port (*PRINTER*. when com1 is not RS485)

You can connect either a strip or label printer to Signum® using a barrier like YDI05-Z (see proof of intrinsic safety, drawing 36953-750-60). Configure the COM1 interface as a printer port under the "*PRINTER*" menu item.

There are several actions that generate the command for outputting data to the printer port:

- Pressing the  key. If the operating menu is active, all menu settings under the active menu level are printed.
- Upon receipt of the "Esc k P _" SBI command. For details, see the section entitled "Data Input Format" in this chapter.
- In some applications, pressing a given key (e.g., to save a value or start a routine) also generates a print command. In this case, a configurable printout is generated with application-specific data.

The ☉ and ☐ symbols are displayed when data is being output to the printer port.

Automatic Data Output (SBI)

You can have the weight readout printed automatically¹⁾. This printout can be generated after a certain number of display updates²⁾. You can also configure whether or not the auto-print function is dependent on the stability of the scale³⁾. The display update frequency depends on both the scale model and the operating status.

Examples:

N	+	153.00 g	Net weight
Stat			Display blank
Stat		L	Display underweight
Stat		H	Display overload

“Data output” setting:

1) ³⁾ “Automatic, without stability”

or

“Automatic, with stability”.

Factory setting: Manual data output after stability;

i.e., automatic data output function off.

2) Time-dependent automatic data output:



Interval: 1, 2, 10 or 100 display updates

Factory setting: 1 display update

GMP-compliant Printouts

When the corresponding menu item is active, the printout is bracketed by a GMP header and a GMP footer (GMP: "Good Manufacturing Practice").

The GMP header precedes the first measured result. The GMP footer is printed after the last result in a series of measurements ("GMP-compliant printout always for several application results," menu item 7.13.3).

To end a series of measured results, press and hold the  key. In this case, the  symbol is displayed after the GMP header is printed and remains in the display until the GMP footer is printed.

A GMP-compliant printout is generated automatically at the conclusion of calibration/adjustment, linearization routines, as well as when you set or clear a preload.

Three examples of GMP headers and one example of a footer are shown in the following.

Weighing platform WP 1:

```
-----
14.01.2017    09:43
Type          SIWX
Ser.no.       12345678
Vers. S3 207.171214
BVers.        00-37-2B
-----
```

```
Dash line
Date/time
Signum® Type
Signum® Serial no.
Software version Application
Software version Basic software
Dash line
```

```
-----
14.01.2017    9:45 AM
Name:
-----
```

```
GMP footer:
Dash line
Date/time
Field for signature
Space line
Dash line
```

Error Messages

Error messages are shown in the main display. *ERR*or messages are shown permanently. *INF*ormation messages are shown for 2 seconds. After this the program automatically returns to the weighing mode.

Display	Cause	Solution
<i>ERR 10 1</i>	Key is stuck Key pressed whilst switching on	Release key or contact your local Minebea Intec Service
Center	Operating program memory faulty	
<i>ERR 320</i>	Incorrect operating parameter (EEPROM)	Contact your local Service Center
<i>ERR 340</i>		Turn the scale off and then on again If the error code is still displayed: Contact your local Service Center
<i>ERR 341</i>	RAM has lost data Battery is empty	Leave the device connected to power for at least 10 hrs.
<i>ERR 343</i>	Loss of data in the memory area for trans- action numbers in external alibi memory	Contact your local Service Center
<i>INF 0 1</i>	Data output not compatible with output format	Set output format correctly
<i>INF 02</i>	Adjustment condition was not met e.g. not tared or weighing pan loaded	Unload the scale first then zero then tare using the  key
<i>INF 03</i>	Adjustment could not be completed within a certain time	Allow to warm up again and repeat the adjustment process
<i>INF 06</i>	Built-in adjustment weight defective	Contact your local Minebea Intec Service Center
<i>INF 07</i>	Function not allowed in scales verified for use in legal metrology	Contact your local Service Center for information on changing settings
<i>INF 08</i>	The load on the scale is too heavy to zero the readout	Check your configuration to ensure that "Zero at power on" (1.12) is set.
<i>INF 09</i>	Taring is not possible when the scale gross weight is zero	Zero the scale.
<i>INF 10</i>	Tare key is blocked when there is data in the tare memory	The data stored for the application program must be deleted before taring.
<i>INF 22</i>	Error in storing reference value, weight is too low	Place a heavier weight on the platform
<i>INF 23</i>	Error in initializing an application	Contact your local Service Center
<i>INF 29</i>	Minimum load not reached	Reduce min. load (under Application, menu item 3.6)
<i>INF 71</i>	Cannot store the current weight value (e.g., control limits too low or too high)	None
<i>INF 72</i>	Cannot store the current weight value (e.g. transaction counter maximum reached)	None
<i>INF 73</i>	Data not found or unreadable	Contact your local Service Center
<i>INF 74</i>	Function is blocked (e.g., menu is locked)	None
<i>INF 98</i>	No weighing platform connected	Contact your local Service Center
<i>INF 99</i>	No weighing platform connected	Contact your local Service Center
<i>NO WP</i>	No weighing platform connected	Contact your local Service Center
Flashing 	Battery defective or time changed	Setting the time
<i>INF 54/L</i>	The load plate is not on the weighing platform	Place the load plate on the platform
<i>INF 55/H</i>	The load exceeds the capacity of the weighing platform	Unload the weighing platform

Care and Maintenance

Service

Regular servicing by a Minebea Intec technician will extend the service life of your equipment and ensure its continued weighing accuracy. Minebea Intec offers its customers service contracts with regular maintenance intervals ranging from 1 month to 2 years.

The frequency of the maintenance intervals depends on the operating conditions and user's tolerance requirements.

Cleaning

- ⚠ Unplug the system from the power supply and unplug any data cables connected to the scale.
- Clean the scale with a cloth lightly moistened with soap solution.
- Wipe down the scale with a soft, moist cloth after cleaning.
- ⚠ Make sure that no liquid enters the scale.
- ⚠ Do not use aggressive cleaning agents (solvents or similar).

Cleaning the Stainless Steel Surfaces

All stainless steel parts should be cleaned at regular intervals. Remove the stainless steel load plate and thoroughly clean it separately. Use a damp cloth or sponge to clean stainless steel parts on the scale. You can use any commercially available household cleaning agent that is suitable for use on stainless steel. Stainless steel should be cleaned simply by rubbing. Then clean the load plate thoroughly, making sure to remove all residues. Use a damp cloth or sponge to clean stainless steel parts on the scale. After this, let the device dry. For additional protection, protective oil may be applied.

- ⚠ Only use solvents for cleaning stainless steel parts.

Corrosive Environment

- Remove all traces of corrosive substances from the scale on a regular basis.

Replacing the Dust Cover

- > Replace damaged dust covers.
- Place the new dust cover on the display and control unit and press it over the edge of the front and rear side of the device until it is fixed in place.

Safety Inspection

If there is any indication that safe operation of the scale is no longer warranted, disconnect the system from the supply voltage and secure it against further use. For example, a safe operation is no longer warranted if the AC adapter has visible damage or is no longer working. Moreover, safety inspections are required

- The equipment has been stored for a relatively long period under unfavorable conditions
- The equipment has been subjected to rough handling during shipment. In this case, notify the Minebea Intec Service Center.

Maintenance and repair work may be performed only by authorized service technicians who have access to the required maintenance manuals and instructions and who have participated in the corresponding training

The duration and number of regular safety inspections should be determined by a qualified Minebea Intec service technician based on specific ambient and operating conditions (once a year at the minimum).

- ⚠ The seals on the device indicate that the device may only be opened and maintained by authorized specialist personnel, so that the correct and safe operation of the device is ensured and the guarantee remains valid. If the verification seals are damaged, the equipment must be re-verified.

Disposal

If the packaging is no longer needed, it can be disposed of by local waste disposal authorities. The packaging is made of environmentally friendly materials that can be used as secondary raw materials.

The equipment, including accessories and batteries, should not be disposed of as regular household waste. EU legislation requires its Member States to collect electrical and electronic equipment and dispose of it separately from other unsorted municipal waste with the aim of recycling it.

In Germany and several other countries, Minebea Intec itself assumes responsibility for the return and conformant disposal of its electronic and electrical products. Such equipment may not be thrown out with household waste or brought to collection centers run by local public disposal operations – not even by small commercial operators.

For disposal in Germany and in the other member nations of the European Economic Area (EEA), please contact our local service technicians or our Service Center in Bovenden, Germany:

Minebea Intec Bovenden GmbH & Co. KG
Leinetal 2

D-37120 Bovenden, Germany

WEEE-Reg.-Nr. DE58091735

In countries that are not members of the European Economic Area (EEA) or where no Minebea Intec subsidiaries or dealerships are located, please contact your local authorities or a commercial disposal operator.

Prior to disposal and/or scrapping of the equipment, any batteries should be removed and disposed of in local collection boxes.

Minebea Intec will not take back equipment contaminated with hazardous materials (ABC contamination) – either for repair or disposal. Detailed information with service addresses for returning your device for repair or disposal can be found on our website (www.minebea-intec.com) or requested from a Minebea Intec Service Center.

General Specifications

Digital protective interface	according to EN45501
Data interface	bidirectional RS-232C interface with control output (standard equipment)
Additional data interface	optional
Display	14-segment backlit display
Weighing platform housing: display unit	Aluminum die-casting, stainless steel
Protection class according to EN60529	IP65 (SIWXSBBP-06*: IP43)
Temperature range	-10°C to +40°C +10°C to +30°C (SIWS...-CE)
Power supply	via AC adapter YPS02-Z.. or YPSC01-Z respectively (for installation outside of the hazardous area only) or YPS02-X.. or YPSC01-X respectively (also for installation within the hazardous areas of the zones 1 and 21). 100-240 V AC (+/-10 %), 50-60 Hz battery operation via external rechargeable battery YRB02-X
Interference emission	acc. to EN61326+A1 Class B (IEC 61326+A1)
Defined immunity to interference	acc. to EN61326+A1, industrial environment (IEC61326+A1)
Electrical safety	acc. to EN61010-1 (IEC 1010-1), EN60950 (IEC 950)

Signum[®] Model Designator

Model type	Sensor technology	Platform dimensions	Material/design	Application level	Weighing capacity (kg)	Display resolution	Verifiable/verified models
Example SIWXS:	SIWXSDCP-3-16-H						
SIWX	S ³⁾	DC	P ⁴⁾	-3	06	S	
		BB	S ⁵⁾		3	H	
					6		
					35		

³⁾ = SIWXS: "Supreme,; monolithic weighing system

⁴⁾ = painted

⁵⁾ = stainless steel

Model-specific Data

Weighing Data Signum® Supreme SIWXSBBP / BBS Non-verifiable models

Weighing capacity (kg)	0.620**	3.1	6.1
Readability (g)	0.001	0.01	0.01
Resolution code	-H	-H	-H
Calibration weight value (in grams)	500	2000	5000
Accuracy class	E2	E1	E2

Verifiable/verified models

Type

EC type approval no.

Weighing capacity (kg)

Readability (g)

Verification scale interval e (g)

Resolution code

Calibration weight value (in grams)

Accuracy class

* not SIWXSBBBS

For all models

Preload (kg)	0	3	3
Repeatability (g)	0.001	0.01	0.01
Linearity (g)	0.002	0.02	0.02
Ambient temperature (for use in legal metrology only)	+10°C...+30°C		

Resolutions for Signum® Supreme

Non-verifiable (type)	Verified at factory (type)
-H	Resolution > 100,000 d

Model-specific Data

Weighing Data Signum® Supreme SIWXSDCP/S (* models not available for SIWSDCS)

Non-verifiable models

Weighing capacity (kg)	6	35
Readability (g)	0.1	0.1
Resolution code	-S	-H
Calibration weight value (in grams)	5,000	10,000
Accuracy class	F2	F1

Verifiable/verified models

Type		
EC type approval no.		
Weighing capacity (kg)		
Readability (g)		
Verification scale interval e (g)		
Resolution code		
Calibration weight value (in grams)		
Accuracy class		

For all models

Preload (kg)	5	5
Repeatability (g) (verified models acc. to EN45501)	0.08	0.08
Linearity (g) (verified models acc. to EN45501)	0.2	0.2
Ambient temperature (for use in legal metrology only)	+10°C....+30°C	

Resolutions for Signum® Supreme

Non-verifiable (type)	Verified at factory (type)
-S	Resolution > 60,000 d
-H	Resolution > 100,000 d

SIWXSBBP 620g

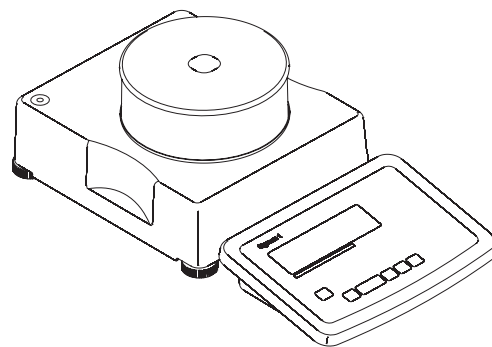
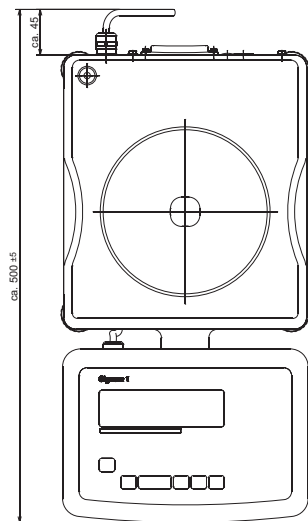
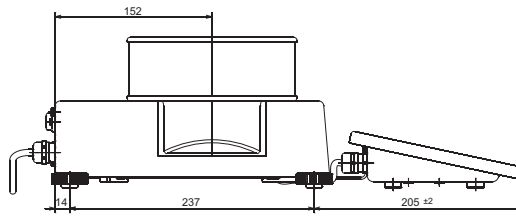
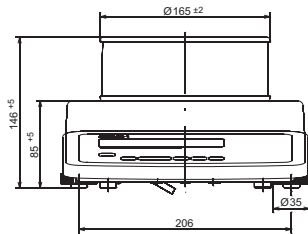

SIWXSBBP 3/6kg

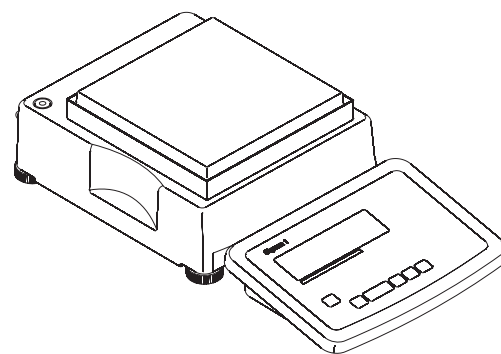
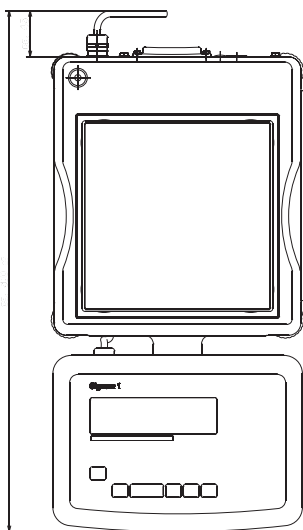
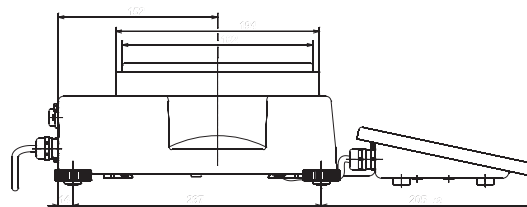
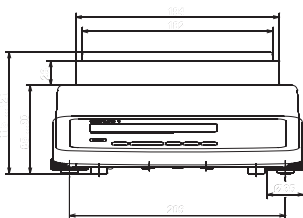

Dimensions (Scale Drawings)

SIWXSBB5:

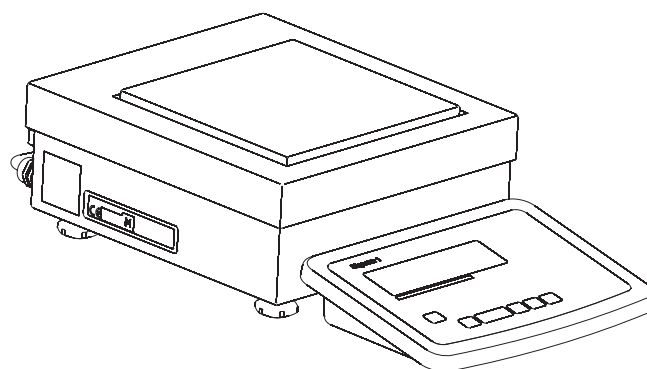
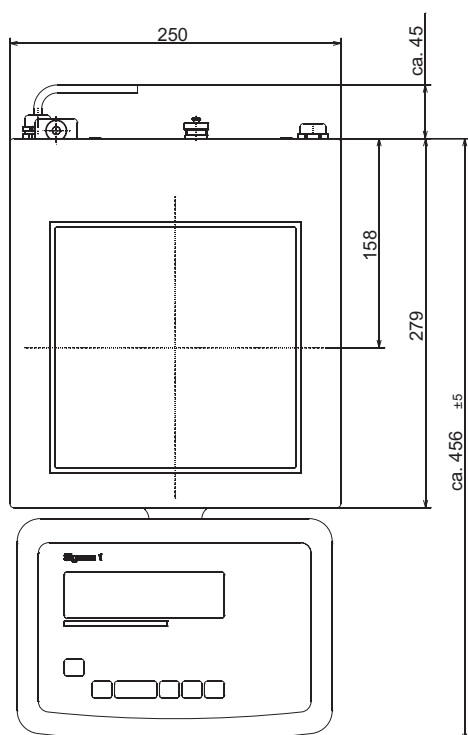
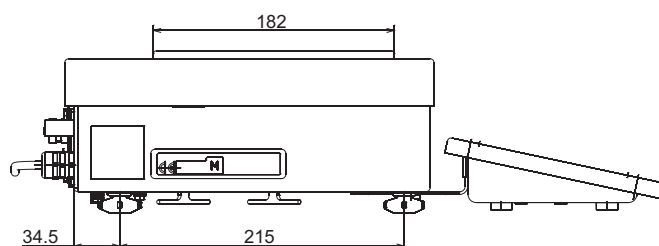
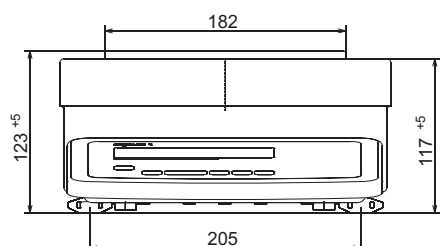

All dimensions are given in millimeters

Accessories

Power Supply:

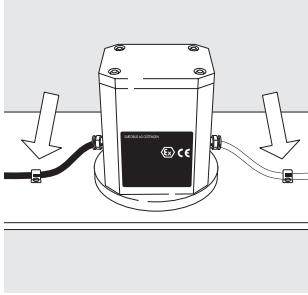

AC adapter, for use in explosive atmospheres
100 -240 V AC

ATEX
FM (US)
CSA

Order No.

YPSC01-X
YPS02-XUR
YPS02-XKR



AC adapter outside explosive atmospheres
100 -240 V AC

ATEX
FM/CSA

YPSC01-Z
YPS02-ZKR

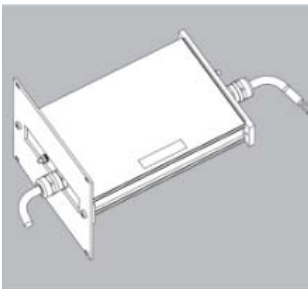

AC adapter outside explosive atmospheres 24 V DC

ATEX

YPS02-XV24



External rechargeable battery for installation in
explosive atmospheres

ATEX, FM, CSA

YRB02-X

Zener Barrier:



Ex interface converter

Order No.

YDI05-Z



Printer for Installation in Non-hazardous Area:

Verifiable data printer with date/time and statistics functions with LCD display
 Strip|label printer, 60 mm paper width
 Strip|label printer, 108 mm paper width
 Thermal transfer printer, 108 mm paper width

Order No.

YDP21
 YDP05
 YDP14IS-0CEUV
 YDP14IS-EUVTH



Software:



SNLE Minebea Intec Nice Label Express
 WinScale
 SartoCollect
 Minebea Intec GMP Connect
 Minebea Intec OPC Server

Order No.

YAD02IS
 YSW03
 YSC02
 YSW03-0001
 6289OPC

Configuration FM



Configuration ATEX



Mechanical Accessories:

	Order No.
Column for BBP model, aluminum, height 400 mm	YDH02P
Column for BBS model, stainless steel, height 400 mm	YDH02S
Column for DCP model, aluminum, height 500 mm	YDH01P
Column for DCS model, stainless steel, height 330 mm	YDH01CWS
Column for DCS model, stainless steel, height 500 mm	YDH02CWS
Column for DCS model, stainless steel, height 750 mm	YDH03CWS
Wall mounting bracket for the display, stainless steel	YDH01CIS
Wall mounting bracket for the display, stainless steel, tiltable indicator	YDH02CIS
Kit for installation in control panel	YAS03MI

Other:

	Order No.
Round plug for individual cable assembly, 14-pin, IP65	69Y03166

“Installation”, a service offered by Minebea Intec

“Installation” service in Germany

Our “Installation” service package provides the following services:

- Installation
- Commissioning
- Inspection
- Instruction

If the installation of the weighing instrument is to be carried out by Minebea Intec, please request this service from a customer service employee.

Re-verification in Germany

Scale verification for legal metrology is valid until the end of the calendar year after next. If the scale is used for fill level control in accordance with legislation on prepackaging, verification is valid until the end of the following calendar year. Re-verification must currently be carried out by a weights and measures official. Re-verification should be requested in good time from the local Weights and Measures office. As appropriate, please observe all statutory amendments.

Subsequent Verifications within European Countries

The expiration date of the verification depends on the national regulations of the country in which the weighing instrument is used. For information on verification and legal regulations currently applicable in your country, and to obtain the names of the persons to contact, please contact your local Minebea Intec office, dealer, or Service Center.

Further information concerning “verification” can be obtained from our customer service centers.



EU- / EG-Konformitätserklärung EU / EC Declaration of Conformity

Hersteller <i>Manufacturer</i>	Minebea Intec Bovenden GmbH & Co. KG Leinetal 2, 37120 Bovenden, Germany
	erklärt in alleiniger Verantwortung, dass das Betriebsmittel <i>declares under sole responsibility that the equipment</i>
Geräteart <i>Device type</i>	Signum Ex Waage Supreme <i>Signum Ex Scale Supreme</i>
Baureihe <i>Type series</i>	SIWXSa-3-b-c, ISXa-b-c a= BBP, BBS, DCP, DCS; b= 06, 3, 6, 16, 35; c= H, HCE, S, SCE
	in der von uns in Verkehr gebrachten Ausführung allen einschlägigen Bestimmungen der folgenden Europäischen Richtlinien - einschließlich deren zum Zeitpunkt der Erklärung geltenden Änderungen - entspricht und die anwendbaren Anforderungen folgender harmonisierter Europäischer Normen erfüllt: <i>in the form as delivered fulfils all the relevant provisions of the following European Directives - including any amendments valid at the time this declaration was signed - and meets the applicable requirements of the harmonized European Standards listed below:</i>
2014/30/EU	Elektromagnetische Verträglichkeit <i>Electromagnetic compatibility</i> EN 61326-1:2013
2006/42/EG 2006/42/EC	<u>Nur</u> für Geräte mit interner Justiergewichtsschaltung / <u>Only</u> for devices with internal calibration weight Maschinen <i>Machines</i> EN ISO 12100:2010
2011/65/EU	Beschränkung der Verwendung bestimmter gefährlicher Stoffe in Elektro- und Elektronikgeräten (RoHS) <i>Restriction of the use of certain hazardous substances in electrical and electronic equipment (RoHS)</i> EN 50581:2012
2014/34/EU	Geräte und Schutzsysteme zur bestimmungsgemäßen Verwendung in explosionsgefährdeten Bereichen <i>Equipment and protective systems intended for use in potentially explosive atmospheres</i> EN 60079-0:2012, EN 60079-11: 2012
Kennzeichnung <i>Marking</i>	II 2G Ex ib IIC T4 Gb II 2D Ex ib IIIC T80°C Db (nur für IP6x Modelle / only for IP6x models)
Zertifizierung <i>Certification</i>	EG-Baumusterprüfbescheinigung Nummer: DEKRA 12ATEX0162 X <i>EC-Type Examination Certificate number:</i>
QAN	Anerkennung der Qualitätssicherung Produktion FM16ATEX00084 <i>Quality Assurance Notification (production)</i>



EU- / EG-Konformitätserklärung EU / EC Declaration of Conformity

Jahreszahl der CE-Kennzeichenvergabe | *Year of the CE mark assignment: 17*

Die Person, die bevollmächtigt ist, die technischen Unterlagen zusammenzustellen:
The person authorised to compile the technical file:

Minebea Intec Bovenden GmbH & Co. KG, Research & Development, Leinetal 2, 37120 Bovenden,
Germany

Minebea Intec Bovenden GmbH & Co. KG
Bovenden, 2017-02-08

Dr. Bodo Krebs
President

Dr. Jörg Hachenberg
Head of Mechatronics

Diese Erklärung bescheinigt die Übereinstimmung mit den genannten EU/EG Richtlinien, ist jedoch keine
Zusicherung von Eigenschaften. Bei einer mit uns nicht abgestimmten Änderung des Produktes verliert diese
Erklärung ihre Gültigkeit. Die (Sicherheits-)hinweise der zugehörigen Produktdokumentation sind zu beachten.

*This declaration certifies conformity with the above mentioned EU/EC Directives, but does not guarantee product
attributes. Unauthorised product modifications make this declaration invalid. The (safety) information in the
associated product documentation must be observed.*



IECEX Certificate of Conformity

INTERNATIONAL ELECTROTECHNICAL COMMISSION IEC Certification Scheme for Explosive Atmospheres

for rules and details of the IECEx Scheme visit www.iecex.com

Certificate No.:	IECEX DEK 12.0050X	Issue No: 3	<u>Certificate history:</u> Issue No. 3 (2017-11-23) Issue No. 2 (2016-05-04) Issue No. 1 (2013-11-15) Issue No. 0 (2013-05-23)
Status:	Current	Page 1 of 4	
Date of Issue:	2017-11-23		
Applicant:	Minebea Intec Bovenden GmbH & Co. KG Leinetal 2 37120 Bovenden Germany		
Equipment:	Intrinsically Safe Weighing Units, Type SIWXS...-3-...-..., SIWXS...-3-V..., ISX...-...-... and ISX...-V...		
Optional accessory:			
Type of Protection:	Ex ib		
Marking:	Ex ib IIC T4 Gb Ex ib IIC T80 °C Db		

Approved for issue on behalf of the IECEx
Certification Body:

R. Schuller

Position:

Certification Manager

Signature:
(for printed version)

Date:

2017-11-23

1. This certificate and schedule may only be reproduced in full.
2. This certificate is not transferable and remains the property of the issuing body.
3. The Status and authenticity of this certificate may be verified by visiting the [Official IECEx Website](http://www.iecex.com).

Certificate issued by:

DEKRA Certification B.V.
Meander 1051,
6825 MJ Arnhem
The Netherlands





IECEX Certificate of Conformity

Certificate No: IECEX DEK 12.0050X Issue No: 3
 Date of Issue: 2017-11-23 Page 2 of 4
 Manufacturer: **Minebea Intec Bovenden GmbH & Co. KG**
 Leinetal 2
 37120 Bovenden
 Germany

Additional Manufacturing location(s):

This certificate is issued as verification that a sample(s), representative of production, was assessed and tested and found to comply with the IEC Standard list below and that the manufacturer's quality system, relating to the Ex products covered by this certificate, was assessed and found to comply with the IECEx Quality system requirements. This certificate is granted subject to the conditions as set out in IECEx Scheme Rules, IECEx 02 and Operational Documents as amended.

STANDARDS:

The electrical apparatus and any acceptable variations to it specified in the schedule of this certificate and the identified documents, was found to comply with the following standards:

IEC 60079-0 : 2011 Explosive atmospheres - Part 0: General requirements
 Edition:6,0
IEC 60079-11 : 2011 Explosive atmospheres - Part 11: Equipment protection by intrinsic safety "I"
 Edition:6,0

*This Certificate **does not** indicate compliance with electrical safety and performance requirements other than those expressly included in the Standards listed above.*

TEST & ASSESSMENT REPORTS:

A sample(s) of the equipment listed has successfully met the examination and test requirements as recorded in

Test Report:

[NL/DEK/ExTR12.0049/00](#) [NL/DEK/ExTR12.0049/01](#) [NL/DEK/ExTR12.0049/02](#)

Quality Assessment Report:

[GB/FME/QAR13.0021/04](#)



IECEx Certificate of Conformity

Certificate No: IECEx DEK 12.0050X

Issue No: 3

Date of Issue: 2017-11-23

Page 3 of 4

Schedule

EQUIPMENT:

Equipment and systems covered by this certificate are as follows:

The intrinsically safe weighing units type SIWXS...-3-... and SIWXS...-3-V... (with display) and type ISX...-... and ISX...-V... (without display) can have an enclosure of type BB or DC, which both can be made of stainless steel or painted aluminum. Except for the enclosure of weighing unit type SIWXSBBP-3-06-H..., ISXBBP-06-H..., SIWXSBBP-06-V1... and ISXBBP-V1... (600 grams range), all enclosures provide a degree of protection of IP6X.

As an option all models can be equipped with an internal motor calibration device to lay an internal weight down on the system by a motor to calibrate the scale.

Ambient temperature range: -10 °C to +40 °C.

For electrical data, refer to Annex.

SPECIFIC CONDITIONS OF USE: YES as shown below:

Electrostatic charges shall be avoided.



IECEX Certificate of Conformity

Certificate No: IECEX DEK 12.0050X

Issue No: 3

Date of Issue: 2017-11-23

Page 4 of 4

DETAILS OF CERTIFICATE CHANGES (for issues 1 and above):

Change of manufacturer name.

Annex:

[Annex IECEX DEK 12.0050 X issue 3 and NL_DEK_ExTR12.0049_02.pdf](#)



Annex to Certificate of Conformity IECEx DEK 12.0050X, issue 3
Annex to NL/DEK/ExTR12.0049/02

Electrical data

Supply circuit (permanently connected cable):
 in type of protection intrinsic safety Ex ib IIC or Ex ib IIIC, only for connection to a certified intrinsically safe circuit, with the following maximum values:

V_1 (pin 2 and 6): $U_i = 12.6 \text{ V}$; $I_i = 133 \text{ mA}$; $P_i = 1.46 \text{ W}$; $C_i = 188 \text{ nF}$; $L_i = 0.0 \text{ mH}$;
 V_2 (pin 1 and 4): $U_i = 12.6 \text{ V}$; $I_i = 133 \text{ mA}$; $P_i = 1.46 \text{ W}$; $C_i = 3 \text{ nF}$; $L_i = 0.0 \text{ mH}$;
 V_3 (pin 5 and 8): $U_i = 8.6 \text{ V}$; $I_i = 187 \text{ mA}$; $P_i = 1.51 \text{ W}$; $C_i = 391 \text{ nF}$; $L_i = 0.0 \text{ mH}$;
 V_4 (pin 3 and 7): $U_i = 12.6 \text{ V}$; $I_i = 150 \text{ mA}$; $P_i = 1.68 \text{ W}$; $C_i = 223 \text{ nF}$; $L_i = 0.1 \text{ mH}$.

Dependent on the internal construction, the weighing unit communicates either via RS232, RS485 or RS422 protocol.

RS485 circuit (Data Interface Connector, pins J/K/M):
 in type of protection intrinsic safety Ex ib IIC or Ex ib IIIC, with the following maximum values:

U_i	$\pm 12.4 \text{ V}$	12.0 V	7.2 V
I_i	130 mA^{***}	164 mA^{***}	Any

***: resistively limited

$P_i = \text{any}$; $C_i = 0.23 \mu\text{F}$; $L_i = 0 \text{ mH}$;

$U_o = 5.2 \text{ V}$; $I_o = 210 \text{ mA}$; $P_o = 263 \text{ mW}$; $C_o = 60 \mu\text{F}$; $L_o = 0.6 \text{ mH}$; $L_o/R_o = 125 \mu\text{H}/\Omega$;

RS422 circuit (Data Interface Connector, all pins):
 in type of protection intrinsic safety Ex ib IIC or Ex ib IIIC, only for connection to a certified intrinsically safe circuit, with the following maximum values:

$U_i = 8.6 \text{ V}$; $I_i = 210 \text{ mA}$; $P_i = 0.5 \text{ W}$; $C_i = 0.5 \mu\text{F}$; $L_i = 0 \text{ mH}$;

$U_o = 5.2 \text{ V}$; $I_o = 290 \text{ mA}$; $P_o = 496 \text{ mW}$; $C_o = 60 \mu\text{F}$; $L_o = 0.3 \text{ mH}$; $L_o/R_o = 50 \mu\text{H}/\Omega$.

RS232 circuit (Data Interface Connector, pins A/J/K/N/M):
 in type of protection intrinsic safety Ex ib IIC or Ex ib IIIC, only for connection to a certified intrinsically safe circuit, with the following maximum values:

$U_i = 12.6 \text{ V}^* / 25.2 \text{ V}^{**}$; $I_i = 328 \text{ mA}^{***}$; $P_i = \text{any}$; $C_i = 2.2 \text{ nF}^* / 0.5 \text{ nF}^{**}$; $L_i = 0 \text{ mH}$;

$U_o = 10.0 \text{ V}^* / 20 \text{ V}^{**}$; $I_o = 101 \text{ mA}^{***}$; $P_o = 253 \text{ mW}$; $C_o = 3 \mu\text{F}^* / 217 \text{ nF}^{**}$; $L_o = 3 \text{ mH}$;

$L_o/R_o = 140 \mu\text{H}/\Omega$;

*: versus ground; **: between lines; ***: resistively limited

Digital I/O signals (Data Interface Connector, pins G/F/E/D/O):

in type of protection intrinsic safety Ex ib IIC or Ex ib IIIC, only for connection to a certified intrinsically safe circuit, with the following maximum values:

$U_i = 8.6 \text{ V}$; $I_i = \text{any}$; $P_i = \text{any}$; $C_i = 0 \text{ nF}$; $L_i = 0 \text{ mH}$;

$U_o = 6.0 \text{ V}$; $I_o = 45 \text{ mA}^{***}$; $P_o = 67 \text{ mW}$; $C_o = 40 \mu\text{F}$; $L_o = 20 \text{ mH}$; $L_o/R_o = 530 \mu\text{H}/\Omega$.

***: resistively limited

All intrinsic safe signals are directly connected to the earthed metal enclosure.



CERTIFICATE

(1) EC-Type Examination

(2) **Equipment and protective systems intended for use in potentially explosive atmospheres - Directive 94/9/EC**

(3) EC-Type Examination Certificate Number: **DEKRA 12ATEX0162 X** Issue Number: **2**

(4) Equipment: **Intrinsically Safe Weighing Units, Type SIWXS...-3-..., SIWXS...-3-V..., ISX...-... and ISX...-V...**

(5) Manufacturer: **Sartorius Industrial Scales GmbH & Co. KG**

(6) Address: **Leinetal 2, 37120 Bovenden, Germany**

(7) This equipment and any acceptable variation thereto is specified in the schedule to this certificate and the documents therein referred to.

(8) DEKRA Certification B.V., notified body number 0344 in accordance with Article 9 of the Council Directive 94/9/EC of 23 March 1994, certifies that this equipment has been found to comply with the Essential Health and Safety Requirements relating to the design and construction of equipment and protective systems intended for use in potentially explosive atmospheres given in Annex II to the directive.

The examination and test results are recorded in confidential test report no. NL/DEK/ExTR12.0049/**.

(9) Compliance with the Essential Health and Safety Requirements has been assured by compliance with:

EN 60079-0 : 2012 EN 60079-11 : 2012

(10) If the sign "X" is placed after the certificate number, it indicates that the equipment is subject to special conditions for safe use specified in the schedule to this certificate.

(11) This EC-Type Examination Certificate relates only to the design, examination and tests of the specified equipment according to the Directive 94/9/EC. Further requirements of the directive apply to the manufacturing process and supply of this equipment. These are not covered by this certificate.

(12) The marking of the equipment shall include the following:



**II 2 G Ex ib IIC T4 Gb
II 2 D Ex ib IIIC T80 °C Db (only for IP6X models)**

This certificate is issued on 15 November 2013 and, as far as applicable, shall be revised before the date of cessation of presumption of conformity of (one of) the standards mentioned above as communicated in the Official Journal of the European Union.

DEKRA Certification B.V.

R. Schüller
R. Schüller
Certification Manager

Page 1/3

© Integral publication of this certificate and adjoining reports is allowed. This Certificate may only be reproduced in its entirety and without any change.



(13) **SCHEDULE**

(14) **to EC-Type Examination Certificate DEKRA 12ATEX0162 X**

Issue No. 2

(15) **Description**

The intrinsically safe weighing units type SIWXS...-3-... and SIWXS...-3-V... (with display) and type ISX...-... and ISX...-V... (without display) can have an enclosure of type BB or DC, which both can be made of stainless steel or painted aluminum.

All enclosures provide a degree of protection of IP6X, except for the enclosure of weighing unit type SIWXSBBP-3-06-H., ISXBBP-06-H., SIWXSBBP-3-V1.. and ISXBBP-V1.. (600 grams range).

As an option all models can be equipped with an internal motor calibration device to lay an internal weight down on the system by a motor to calibrate the scale.

Ambient temperature range: -10 °C to +40 °C.

Electrical data

Supply circuit (permanently connected cable):

in type of protection intrinsic safety Ex ib IIC or Ex ib IIIC, only for connection to a certified intrinsically safe circuit, with the following maximum values:

V_1 (pin 2 and 6): $U_i = 12,6 \text{ V}$; $I_i = 133 \text{ mA}$; $P_i = 1,46 \text{ W}$; $C_i = 188 \text{ nF}$; $L_i = 0,0 \text{ mH}$;

V_2 (pin 1 and 4): $U_i = 12,6 \text{ V}$; $I_i = 133 \text{ mA}$; $P_i = 1,46 \text{ W}$; $C_i = 3 \text{ nF}$; $L_i = 0,0 \text{ mH}$;

V_3 (pin 5 and 8): $U_i = 8,6 \text{ V}$; $I_i = 187 \text{ mA}$; $P_i = 1,51 \text{ W}$; $C_i = 391 \text{ nF}$; $L_i = 0,0 \text{ mH}$;

V_4 (pin 3 and 7): $U_i = 12,6 \text{ V}$; $I_i = 150 \text{ mA}$; $P_i = 1,68 \text{ W}$; $C_i = 223 \text{ nF}$; $L_i = 0,1 \text{ mH}$.

Power Supply Type YPS02-...X.. (Certificate KEMA 98ATEX0892 X), Power Supply Type YPS02-Z.. (Certificate KEMA 98ATEX0611X) and Power Supply Type YPSC01-X and YPSC01-Z (Certificate KEMA 08ATEX0044) may be applied to fulfil these maximum electric values.

Dependent on the internal construction, the weighing unit communicates either via RS232, RS485 or RS422 protocol.

RS485 circuit (Data Interface Connector, pins J/K/M):

in type of protection intrinsic safety Ex ib IIC or Ex ib IIIC, only for connection to a certified intrinsically safe circuit, with the following maximum values:

U_i	$\pm 12,4 \text{ V}$	$12,0 \text{ V}$	$7,2 \text{ V}$
I_i	130 mA^{***}	164 mA^{***}	Any

***: resistively limited

$P_i = \text{any}$; $C_i = 0,23 \mu\text{F}$; $L_i = 0 \text{ mH}$;

$U_o = 5,2 \text{ V}$; $I_o = 210 \text{ mA}$; $P_o = 263 \text{ mW}$; $C_o = 60 \mu\text{F}$; $L_o = 0,6 \text{ mH}$; $L_o/R_o = 125 \mu\text{H}/\Omega$;

RS422 circuit (Data Interface Connector, all pins):

in type of protection intrinsic safety Ex ib IIC or Ex ib IIIC, only for connection to a certified intrinsically safe circuit, with the following maximum values:

$U_i = 8,6 \text{ V}$; $I_i = 210 \text{ mA}$; $P_i = 0,5 \text{ W}$; $C_i = 0,5 \mu\text{F}$; $L_i = 0 \text{ mH}$;

$U_o = 5,2 \text{ V}$; $I_o = 290 \text{ mA}$; $P_o = 496 \text{ mW}$; $C_o = 60 \mu\text{F}$; $L_o = 0,3 \text{ mH}$; $L_o/R_o = 50 \mu\text{H}/\Omega$.

(13) **SCHEDULE**(14) **to EC-Type Examination Certificate DEKRA 12ATEX0162 X**

Issue No. 2

RS232 circuit (Data Interface Connector, pins A/J/K/N/M):

in type of protection intrinsic safety Ex ib IIC or Ex ib IIIC, only for connection to a certified intrinsically safe circuit, with the following maximum values:

$U_i = 12,6 \text{ V}^* / 25,2 \text{ V}^{**}$; $I_i = 328 \text{ mA}^{***}$; $P_i = \text{any}$; $C_i = 2,2 \text{ nF}^* / 0,5 \text{ nF}^{**}$; $L_i = 0 \text{ mH}$;

$U_o = 10,0 \text{ V}^* / 20 \text{ V}^{**}$; $I_o = 101 \text{ mA}^{***}$; $P_o = 253 \text{ mW}$; $C_o = 3 \text{ }\mu\text{F}^* / 217 \text{ nF}^{**}$; $L_o = 3 \text{ mH}$;

$L_o/R_o = 140 \text{ }\mu\text{H}/\Omega$;

*: versus ground; **: between lines; ***: resistively limited

Digital I/O signals (Data Interface Connector, pins G/F/E/D/O):

in type of protection intrinsic safety Ex ib IIC or Ex ib IIIC, only for connection to a certified intrinsically safe circuit, with the following maximum values:

$U_i = 8,6 \text{ V}$; $I_i = \text{any}$; $P_i = \text{any}$; $C_i = 0 \text{ nF}$; $L_i = 0 \text{ mH}$;

$U_o = 6,0 \text{ V}$; $I_o = 45 \text{ mA}^{***}$; $P_o = 67 \text{ mW}$; $C_o = 40 \text{ }\mu\text{F}$; $L_o = 20 \text{ mH}$; $L_o/R_o = 530 \text{ }\mu\text{H}/\Omega$.

***: resistively limited

All intrinsic safe signals are directly connected to the earthed metal enclosure.

Installation instructions

The instructions provided by the manufacturer shall be followed in detail to assure safe operation of the equipment.

(16) **Test Report**

No. NL/DEK/ExTR12.0049/**.

(17) **Special conditions for safe use**

Electrostatic charges shall be avoided.

(18) **Essential Health and Safety Requirements**

Assured by compliance with the standards listed at (9).

(19) **Test documentation**

As listed in Test Report No. NL/DEK/ExTR12.0049/**.



CERTIFICATE OF CONFORMITY

1. **HAZARDOUS (CLASSIFIED) LOCATION ELECTRICAL EQUIPMENT PER US REQUIREMENTS**
2. **Certificate No:** FM17US0329X
3. **Equipment:**
(Type Reference and Name)
 - SIWXSabc-d-ef-ghi. Weighing Unit.*
 - SIWXSabc-d-Vklm. Weighing Unit.*
 - ISXabc-ef-ghi. Weighing Unit.*
 - ISXabc-Vklm. Weighing Unit.*
 - SIWXSBBP-3-06-Hhi. Weighing Unit.*
 - SIWXSBBP-3-V1lm. Weighing Unit.*
 - ISXBBP-3-06-Hhi. Weighing Unit.*
 - ISXabc-V1lm. Weighing Unit.*
4. **Name of Listing Company:** Minebea Intec Bovenden GmbH & Co. KG
5. **Address of Listing Company:**
 - Leinetal 2
 - 37120 Bovenden
 - Germany
6. The examination and test results are recorded in confidential report number:
3047194 dated 19th June 2013
7. FM Approvals LLC, certifies that the equipment described has been found to comply with the following Approval standards and other documents:
 - FM Class 3600:2011, FM Class 3610:2010, FM Class 3810:2005,
 - ANSI/ISA 60079-0:2009, ANSI/ISA 60079-11:2012
8. If the sign 'X' is placed after the certificate number, it indicates that the equipment is subject to specific conditions of use specified in the schedule to this certificate.

Certificate issued by:

J.E. Marquedant
 J.E. Marquedant
 VP, Manager, Electrical Systems

18 December 2017
 Date

To verify the availability of the Approved product, please refer to www.approvalguide.com

THIS CERTIFICATE MAY ONLY BE REPRODUCED IN ITS ENTIRETY AND WITHOUT CHANGE

FM Approvals LLC, 1151 Boston-Providence Turnpike, Norwood, MA 02062 USA
 T: +1 (1) 781 762 4300 F: +1 (1) 781 762 9375 E-mail: information@fmapprovals.com www.fmapprovals.com

SCHEDULE



US Certificate Of Conformity No: FM17US0329X

9. This certificate relates to the design, examination and testing of the products specified herein. The FM Approvals surveillance audit program has further determined that the manufacturing processes and quality control procedures in place are satisfactory to manufacture the product as examined, tested and Approved.

10. Equipment Ratings:

SIWXSabc-d-ef-ghi. Weighing Unit.

SIWXSabc-d-Vklm. Weighing Unit.

ISXabc-ef-ghi. Weighing Unit.

ISXabc-Vklm. Weighing Unit.

IP6X Models: SIWXS Scale and ISX Weighing platform as Intrinsically Safe for use in Class I, II and III, Division 1, Groups A, B, C, D, E, F and G; Class I, Zone 1, AEx ib Group IIC in accordance with Control Drawing 36953-751-07; Temperature Class T4; Hazardous Indoor (Classified) Locations over a temperature range of -10°C to +40°C. Zone 21, AEx ib Group IIIC; in accordance with Control Drawing 36953-751-07; T80°C; Hazardous Indoor (Classified) Locations over a temperature range of -10°C to +40°C.

SIWXSBBP-3-06-Hhi. Weighing Unit.

SIWXSBBP-3-V1lm. Weighing Unit.

ISXBBP-3-06-Hhi. Weighing Unit.

ISXabc-V1lm. Weighing Unit.

IP4X Models: SIWXSBBP-3-06-H & SIWXSBBP-3-V1lm Scale and ISXBBP-3-06-H & ISXabc-V1lm Weighing platform as Intrinsically Safe for use in Class I, Division 1, Groups A, B, C and D; Class I, Zone 1, AEx ib Group IIC; in accordance with Control Drawing 36953-751-07; Temperature Class T4; Hazardous Indoor (Classified) Locations over a temperature range of -10°C to +40°C.

11. The marking of the equipment shall include:

SIWXSabc-d-ef-ghi. Weighing Unit.

SIWXSabc-d-Vklm. Weighing Unit.

ISXabc-ef-ghi. Weighing Unit.

ISXabc-Vklm. Weighing Unit.

IS CL, I, II, III, DIV 1, GP A,B,C,D,E,F,G T4

CL I, Zone 1, AEx ib IIC T4

Zone 21, AEx ib IIIC T80°C

-10°C ≤ Ta ≤ +40°C

SIWXSBBP-3-06-Hhi. Weighing Unit.

SIWXSBBP-3-V1lm. Weighing Unit.

ISXBBP-3-06-Hhi. Weighing Unit.

ISXabc-V1lm. Weighing Unit.

IS CL, I, DIV 1, GP A,B,C,D T4

CL I, Zone 1, AEx ib IIC T4

-10°C ≤ Ta ≤ +40°C

12. **Description of Equipment:**

General - The SIWXS scale series consists of a weighing module (platform) and a display unit located in the hazardous area. The platform series ISX consists of a weighing module only and is located in the hazardous area.

THIS CERTIFICATE MAY ONLY BE REPRODUCED IN ITS ENTIRETY AND WITHOUT CHANGE

FM Approvals LLC, 1151 Boston-Providence Turnpike, Norwood, MA 02062 USA

T: +1 (1) 781 762 4300 F: +1 (1) 781 762 9375 E-mail: information@fmaprovals.com www.fmaprovals.com

F 347 (Mar 16)

Page 2 of 3

SCHEDULE



US Certificate Of Conformity No: FM17US0329X

Construction - The housing of the display unit consists of stainless steel with a membrane switch adhered to the front panel. The display housing is two pieces and uses a gasket to prevent ingress of dust for IP6X model types. The weighing modules consist of painted aluminium and/or stainless steel.

Ratings – All model types operate in an ambient temperature range of -10°C to +40°C. The maximum surface temperature for dusts of the SIWXSabc-d-ef-ghi Weighing Unit and the ISXabc-ef-ghi. Weighing Unit is 80°C.

13. Specific Conditions of Use:

1. Electrostatic charging of the equipment shall be avoided; clean only with a damp cloth.

14. Test and Assessment Procedure and Conditions:

This Certificate has been issued in accordance with FM Approvals US Certification Requirements.

15. Schedule Drawings

A copy of the technical documentation has been kept by FM Approvals.

16. Certificate History

Details of the supplements to this certificate are described below:

Date	Description
19 th June 2013	Original Issue.
18 th December 2017	<u>Supplement 3:</u> Report Reference: – RR210598 dated 18 th December 2017 Description of the Change: Documentation updates. Company name change from Sartorius Industrial Scales GmbH & Co. KG. Reformat of Certificate.

THIS CERTIFICATE MAY ONLY BE REPRODUCED IN ITS ENTIRETY AND WITHOUT CHANGE

FM Approvals LLC. 1151 Boston-Providence Turnpike, Norwood, MA 02062 USA
 T: +1 (1) 781 762 4300 F: +1 (1) 781 762 9375 E-mail: information@fmapprovals.com www.fmapprovals.com

CERTIFICATE OF CONFORMITY



Member of the FM Global Group

1. HAZARDOUS LOCATION ELECTRICAL EQUIPMENT PER CANADIAN REQUIREMENTS

- 2. **Certificate No:** FM17CA0166X
- 3. **Equipment:** *SIWXSabc-d-ef-ghi. Weighing Unit.*
(Type Reference and Name) *SIWXSabc-d-Vklm. Weighing Unit.*

ISXabc-ef-ghi. Weighing Unit.
ISXabc-Vklm. Weighing Unit.

SIWXSBBP-3-06-Hhi. Weighing Unit.
SIWXSBBP-3-V1lm. Weighing Unit.

ISXBBP-3-06-Hhi. Weighing Unit.
ISXabc-V1lm. Weighing Unit.

4. **Name of Listing Company:** Minebea Intec Bovenden GmbH & Co. KG

5. **Address of Listing Company:** Leinetal 2
37120 Bovenden
Germany

6. The examination and test results are recorded in confidential report number:

3047194 dated 19th June 2013

7. FM Approvals LLC, certifies that the equipment described has been found to comply with the following Approval standards and other documents:

CSA-C22.2 No. 0157-92:R2012, CSA-C22.2 No. 61010-1:R2009,
CAN/CSA-C22.2 No. 60079-0:2011, CAN/CSA-C22.2 No. 60079-11:2011

8. If the sign 'X' is placed after the certificate number, it indicates that the equipment is subject to specific conditions of use specified in the schedule to this certificate.

Certificate issued by:

J.E. Marquedant
VP, Manager, Electrical Systems

18 December 2017

Date

To verify the availability of the Approved product, please refer to www.approvalguide.com

THIS CERTIFICATE MAY ONLY BE REPRODUCED IN ITS ENTIRETY AND WITHOUT CHANGE

FM Approvals LLC, 1151 Boston-Providence Turnpike, Norwood, MA 02062 USA
T: +1 (1) 781 762 4300 F: +1 (1) 781 762 9375 E-mail: information@fmapprovals.com www.fmapprovals.com

SCHEDULE



Canadian Certificate Of Conformity No: FM17CA0166X

9. This certificate relates to the design, examination and testing of the products specified herein. The FM Approvals surveillance audit program has further determined that the manufacturing processes and quality control procedures in place are satisfactory to manufacture the product as examined, tested and Approved.

10. Equipment Ratings:

SIWXSabc-d-ef-ghi. Weighing Unit.

SIWXSabc-d-Vklm. Weighing Unit.

ISXabc-ef-ghi. Weighing Unit.

ISXabc-Vklm. Weighing Unit.

IP6X Models: SIWXS Scale and ISX Weighing platform as Intrinsically Safe for use in Class I, II and III, Division 1, Groups A, B, C, D, E, F and G; Class I, Zone 1, Ex ib Group IIC in accordance with Control Drawing 36953-751-07; Temperature Class T4; Hazardous Indoor Locations over a temperature range of -10°C to +40°C.

SIWXSBBP-3-06-Hhi. Weighing Unit.

SIWXSBBP-3-V1lm. Weighing Unit.

ISXBBP-3-06-Hhi. Weighing Unit.

ISXabc-V1lm. Weighing Unit.

IP4X Models: SIWXSBBP-3-06-H & SIWXSBBP-3-V1lm Scale and ISXBBP-3-06-H & ISXabc-V1lm Weighing platform as Intrinsically Safe for use in Class I, Division 1, Groups A, B, C and D; Class I, Zone 1, Ex ib Group IIC; in accordance with Control Drawing 36953-751-07; Temperature Class T4; Hazardous Indoor Locations over a temperature range of -10°C to +40°C.

11. The marking of the equipment shall include:

SIWXSabc-d-ef-ghi. Weighing Unit.

SIWXSabc-d-Vklm. Weighing Unit.

ISXabc-ef-ghi. Weighing Unit.

ISXabc-Vklm. Weighing Unit.

IS CL, I, II, III, DIV 1, GP A,B,C,D,E,F,G T4

CL I, Zone 1, Ex ib IIC T4

-10°C ≤ Ta ≤ +40°C

SIWXSBBP-3-06-Hhi. Weighing Unit.

SIWXSBBP-3-V1lm. Weighing Unit.

ISXBBP-3-06-Hhi. Weighing Unit.

ISXabc-V1lm. Weighing Unit.

IS CL, I, DIV 1, GP A,B,C,D T4

CL I, Zone 1, Ex ib IIC T4

-10°C ≤ Ta ≤ +40°C

12. **Description of Equipment:**

General - The SIWXS scale series consists of a weighing module (platform) and a display unit located in the hazardous area. The platform series ISX consists of a weighing module only and is located in the hazardous area.

Construction - The housing of the display unit consists of stainless steel with a membrane switch adhered to the front panel. The display housing is two pieces and uses a gasket to prevent ingress of dust for IP6X model types. The weighing modules consist of painted aluminium and/or stainless steel.

THIS CERTIFICATE MAY ONLY BE REPRODUCED IN ITS ENTIRETY AND WITHOUT CHANGE

FM Approvals LLC, 1151 Boston-Providence Turnpike, Norwood, MA 02062 USA

T: +1 (1) 781 762 4300 F: +1 (1) 781 762 9375 E-mail: information@fmaprovals.com www.fmaprovals.com

SCHEDULE



Canadian Certificate Of Conformity No: FM17CA0166X

Ratings – All model types operate in an ambient temperature range of -10°C to +40°C.

13. Specific Conditions of Use:

1. Electrostatic charging of the equipment shall be avoided; clean only with a damp cloth.

14. Test and Assessment Procedure and Conditions:

This Certificate has been issued in accordance with FM Approvals Canadian Certification Scheme.

15. Schedule Drawings

A copy of the technical documentation has been kept by FM Approvals.

16. Certificate History

Details of the supplements to this certificate are described below:

Date	Description
19 th June 2013	Original Issue.
18 th December 2017	<u>Supplement 3:</u> Report Reference: – RR210598 dated 18 th December 2017 Description of the Change: Documentation updates. Company name change from Sartorius Industrial Scales GmbH & Co. KG. Reformat of Certificate.

THIS CERTIFICATE MAY ONLY BE REPRODUCED IN ITS ENTIRETY AND WITHOUT CHANGE

FM Approvals LLC. 1151 Boston-Providence Turnpike, Norwood, MA 02062 USA
 T: +1 (1) 781 762 4300 F: +1 (1) 781 762 9375 E-mail: information@fmapprovals.com www.fmapprovals.com

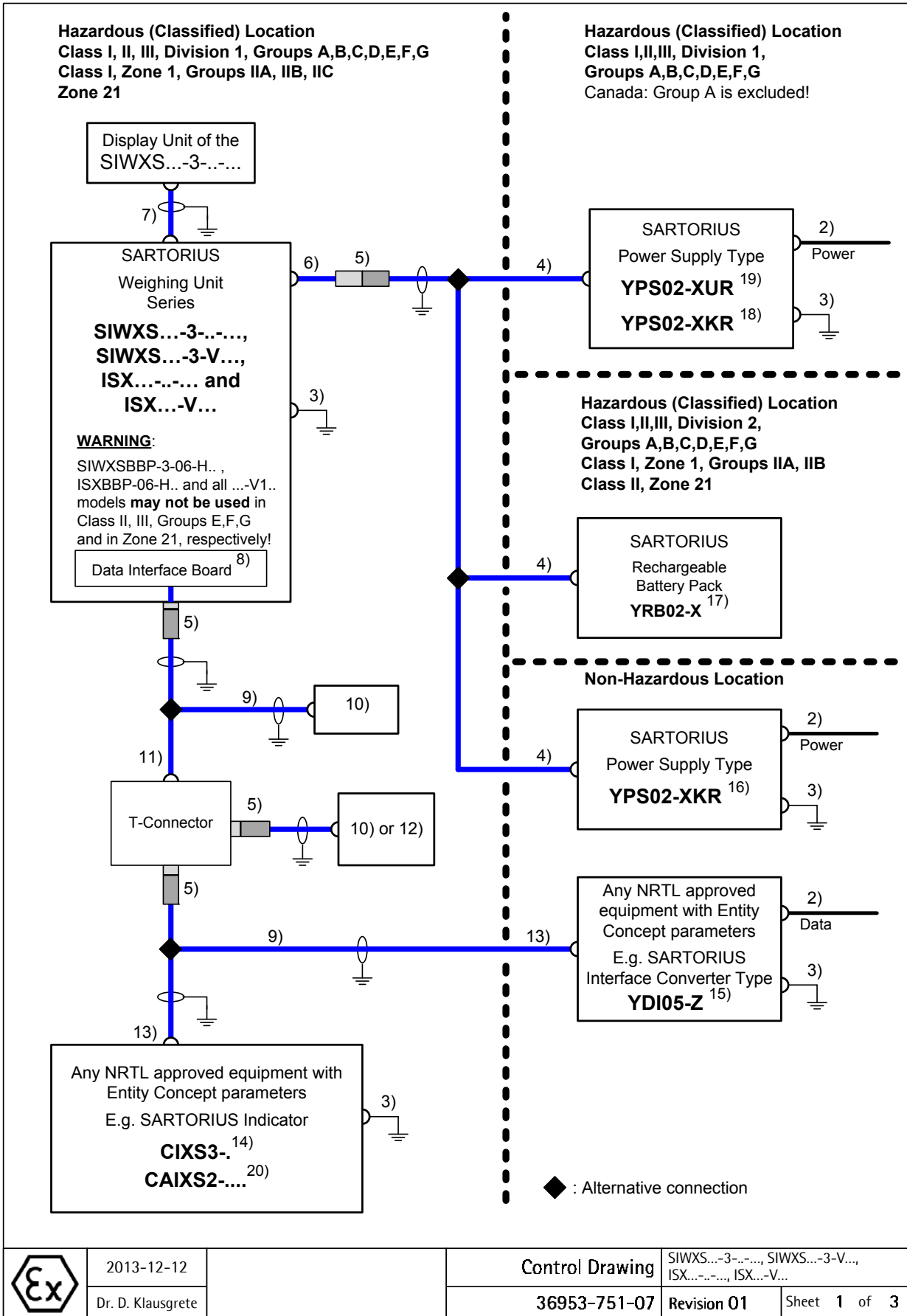

2013-12-12
 Dr. D. Klausgrete

Control Drawing
 36953-751-07

SIWXS...-3-...-..., SIWXS...-3-V...,
 ISX...-...-..., ISX...-V...

Revision 01 Sheet 1 of 3

Data Interface of the SIWXS...-3-...-..., SIWXS...-3-V..., ISX...-...-... and ISX...-V...

RS232 + Digital I/Os	RS422	RS485 + Digital I/Os	Pin
CTS	GND	GND	A
RxD	GND	TxD-RxD_P	J
TxD	TxD_N	TxD_RxD_N	K
DTR	TxD_P	---	N
GND	DRT_P	GND	C
GND	RxD_N	GND	M
GND	DTR_N	GND	B
UNI_IN	---	UNI_IN	O
SET	---	SET	D
PAR	CTS_N	PAR	E
MIN	CTS_P	MIN	F
MAJ	RxD_P	MAJ	G

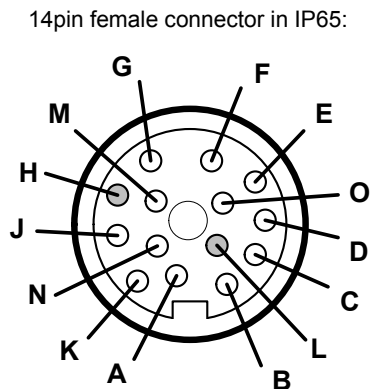

Input parameters (combined circuits):

	Ui	li	Pi	Ci	Li
RS232	12.6 V* 25.2 V**	328 mA***	any	2.2 nF*/0.5nF**	0 mH
RS422	8.6 V	210 mA	0.5 W	0.5 µF	0 mH
RS485	see below	see below	any	260 nF	0 mH
Digital I/Os	8.6 V	any	any	0 µF	0 mH

*: versus ground; **: between the lines; ***: resistively limited

RS485 ($R_{min} = U_i / I_i$ is the minimum output resistance of the combined circuits of the equipment connected to the SIWXS...-3-... or ISXS...-...-...):

Ui	±12.4V	12.0V	7.2V
Ii	130 mA***	164mA***	any
Rmin	95Ω	73Ω	any

Output parameters (combined circuits):

	Uo	Io	Po	Co	Lo	Lo/Ro
RS232	10.0 V* 20.0 V**	101 mA***	253 mW	3 µF* 217 nF**	3 mH	140µH/Ω
RS422	5.2 V	290 mA	496 mW	60 µF	300 µH	50µH/Ω
RS485	5.2 V	210 mA***	263 mW	60 µF	600 µH	125 µH/Ω
Digital I/Os	6.0 V	45 mA***	67 mW	40 µF	20 mH	530 µH/Ω

*: versus ground; **: between the lines; ***: resistively limited



2013-12-12
Dr. D. Klausgrete

Control Drawing

36953-751-07

SIWXS...-3-...-..., SIWXS...-3-V...,
ISX...-...-..., ISX...-V...

Revision 01

Sheet 2 of 3

Notes

- 1) In the **USA**: The installation must be in accordance with the National Electrical Code[®], NFPA 70, Article 504 or 505 and ANSI / ISA-RP 12.6.
- In **Canada**: The installation must be in accordance with the Canadian Electrical Code[®], Part1, Section 18.
- 2) The apparatus must not be connected to any device that uses or generates in excess of 250Vrms or DC.
 $U_m = 250V$.
- 3) In the **USA**: The Apparatus must be connected to a suitable ground electrode per National Electrical Code[®], NFPA 70, Article 504 or 505. The resistance of the ground pad must be less than 1 ohm.
- In **Canada**: The Apparatus must be connected to a suitable ground electrode per Canadian Electrical Code[®], Part 1. The resistance of the ground pad must be less than 1 ohm.
- 4) Connection by non interchangeable cable type LiYC-Y-CY 4 x 0.5; max length: 50m (164 ft).
- 5) Connection by means of polarized connector outside of the indicator.
- 6) Connection by non interchangeable cable type LiYC-Y-CY 4 x 0.5; max length: 0.5m (1.6 ft).
- 7) The cable must be protected against damage.
- 8) The circuits of the data output interface shall be assumed to be connected to earth.
- 9) The cable needs not be protected against damage.
- 10) Equipment with metallic housing (IP4x in minimum) and passive wiring, only. For use in Class II,III, Division 1 and in Zone 21 the housing must be IP6x.
- 11) The cable to the T-Connector must be protected against damage.
- 12) Any NRTL approved equipment with Entity Concept parameters (see note 13)
- 13) The Entity Concept allows interconnection of intrinsically safe apparatus with associated apparatus not specifically examined in combination as a system when the approved values of Voc, Isc and Pmax resp. Uo, Io, Po of the associated apparatus are less than or equal to Vmax, Imax and Pmax resp. Ui, Ii, Pi of the intrinsically safe apparatus and the approved values of Ca and La resp. Co and Lo of the associated apparatus are greater than Ci and Li of the intrinsically safe apparatus plus all cable parameters.
- For the input and output parameters of the data interface of the SIWXS...-3-... / ISX...-... see page 2.
- 14) The Sartorius Indicator Series CIXS3- is approved/certified by FM for use in the USA and in Canada. See Certificate of Compliance and Control Drawing number 65607-000-07-A4.
- 15) The Sartorius Interface Converter YDI05-Z.. is approved/certified by FM for use in the USA and in Canada. See Certificate of Compliance and Control Drawing number 65710-800-07-A4.
- 16) The Sartorius Power Supply Model YPS02-ZKR is approved/certified by FM for use in the USA and in Canada. See Certificate of Compliance and Control Drawing number 65501-000-17.
- 17) The Sartorius rechargeable battery pack YRB02-X is approved/certified by FM for use in the USA and in Canada. See Certificate of Compliance and Control Drawing number 65656-000-07-A4.
- 18) The Sartorius Power Supply Model YPS02-XKR is /certified by CSA for use in Canada. See Certificate of Compliance and Control Drawing number 65516-000-17.
- 19) The Sartorius Power Supply Model YPS02-XUR is approved by FM for use in the USA. See Certificate of Compliance and Control Drawing number 65516-000-17.
- 20) The Sartorius Indicator Series CAIXS2-.... is approved/certified by FM for use in the USA and in Canada. See Certificate of Compliance and Control Drawing number 66015-751-07.
- 21) Ambient temperature range: -10°C +40°C (14°F +104°F) The temperature class for gases of the SIWXS... / ISX... is T4. The maximum surface temperature for dusts of the SIWXS... / ISX... is 80°C (176°F).
- 22) **WARNING:** SUBSTITUTION OF COMPONENTS MAY IMPAIR INTRINSIC SAFETY.
AVERTISSEMENT: LA SUBSTITUTION DE COMPOSANTS PEUT COMPROMETTRE LA SÉCURITÉ INTRINSÈQUE.



2013-12-12

Dr. D. Klausgrete

Control Drawing

SIWXS...-3-...-..., SIWXS...-3-V...
ISX...-...-..., ISX...-V...

36953-751-07

Revision 01

Sheet 3 of 3

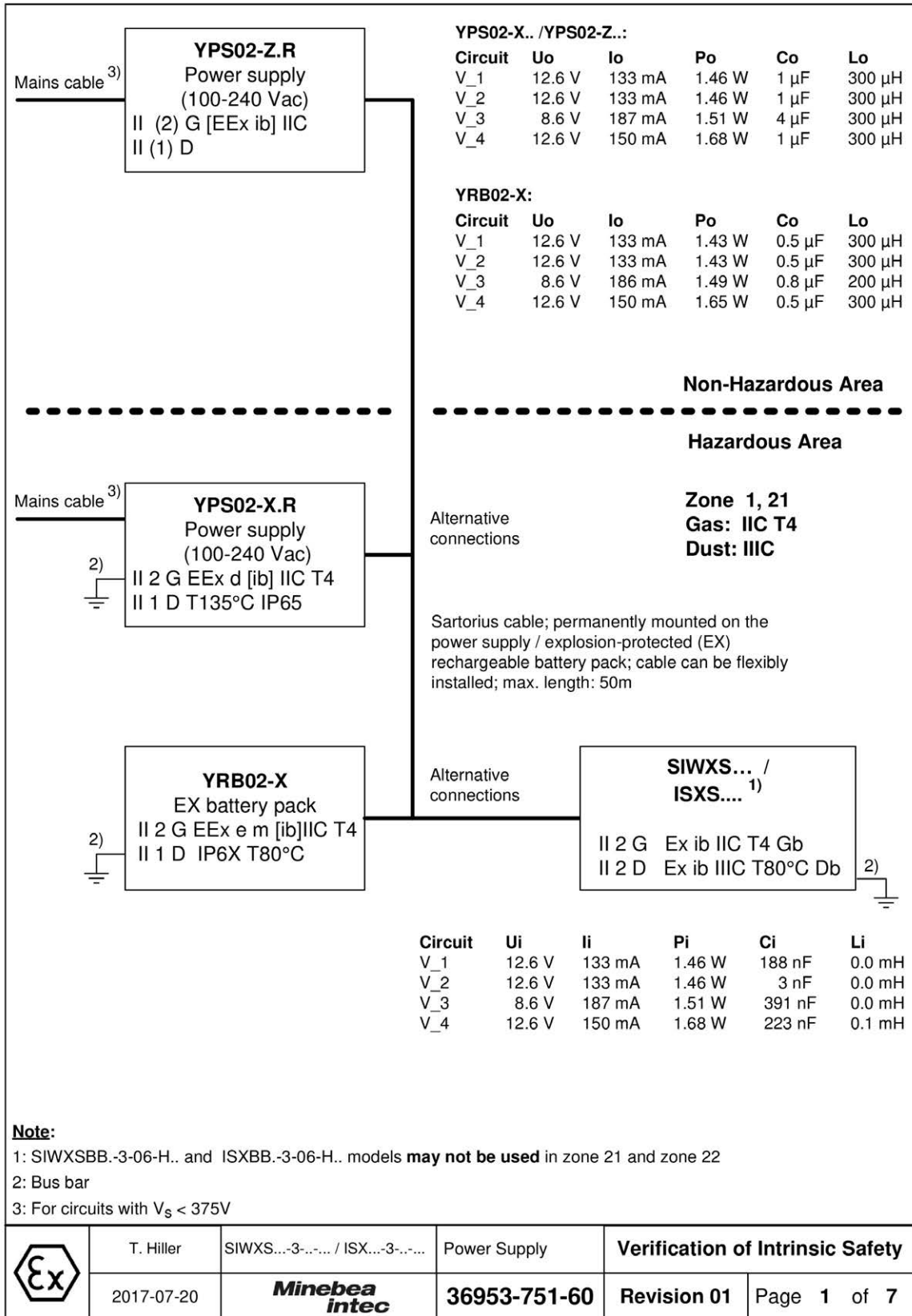

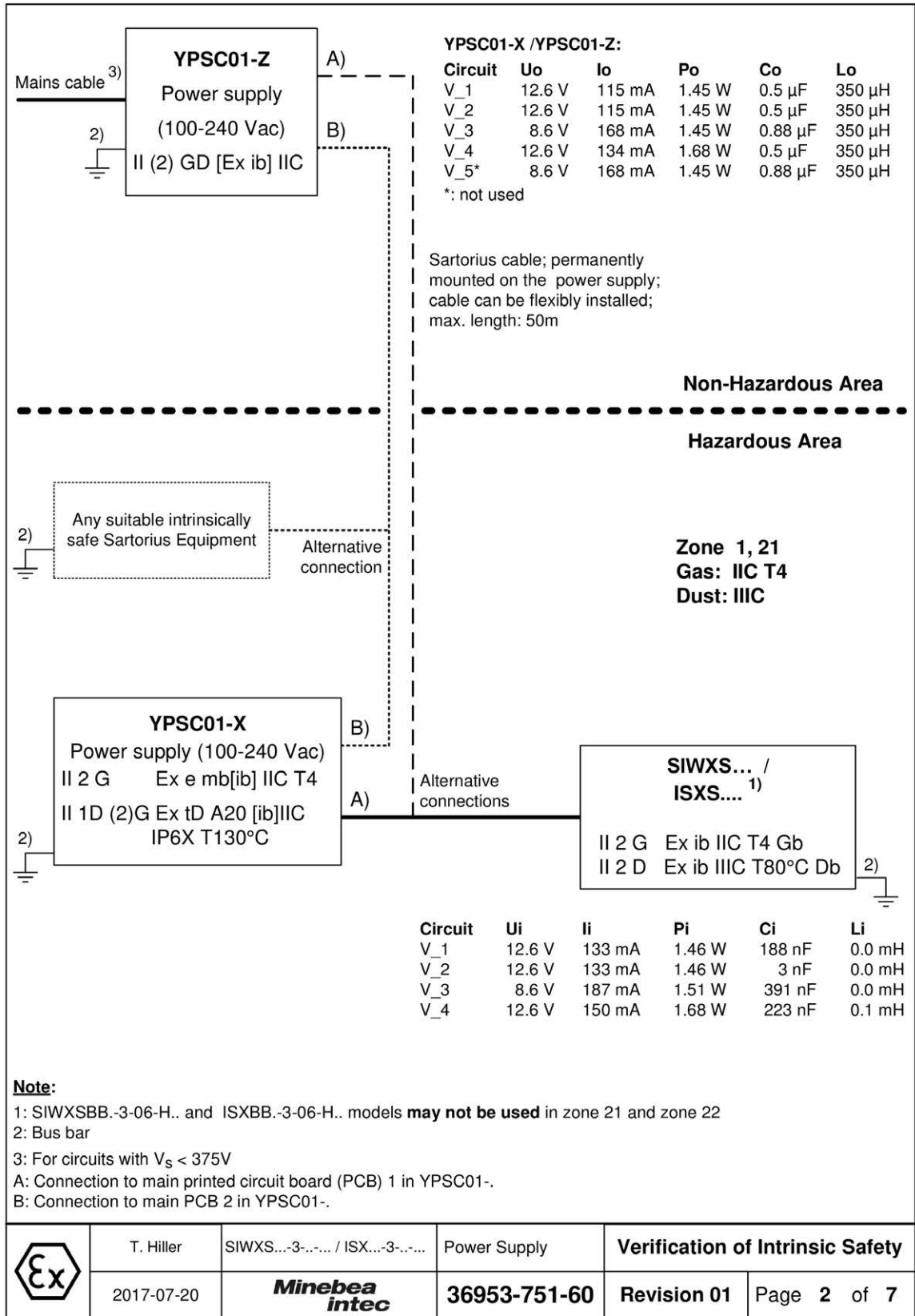

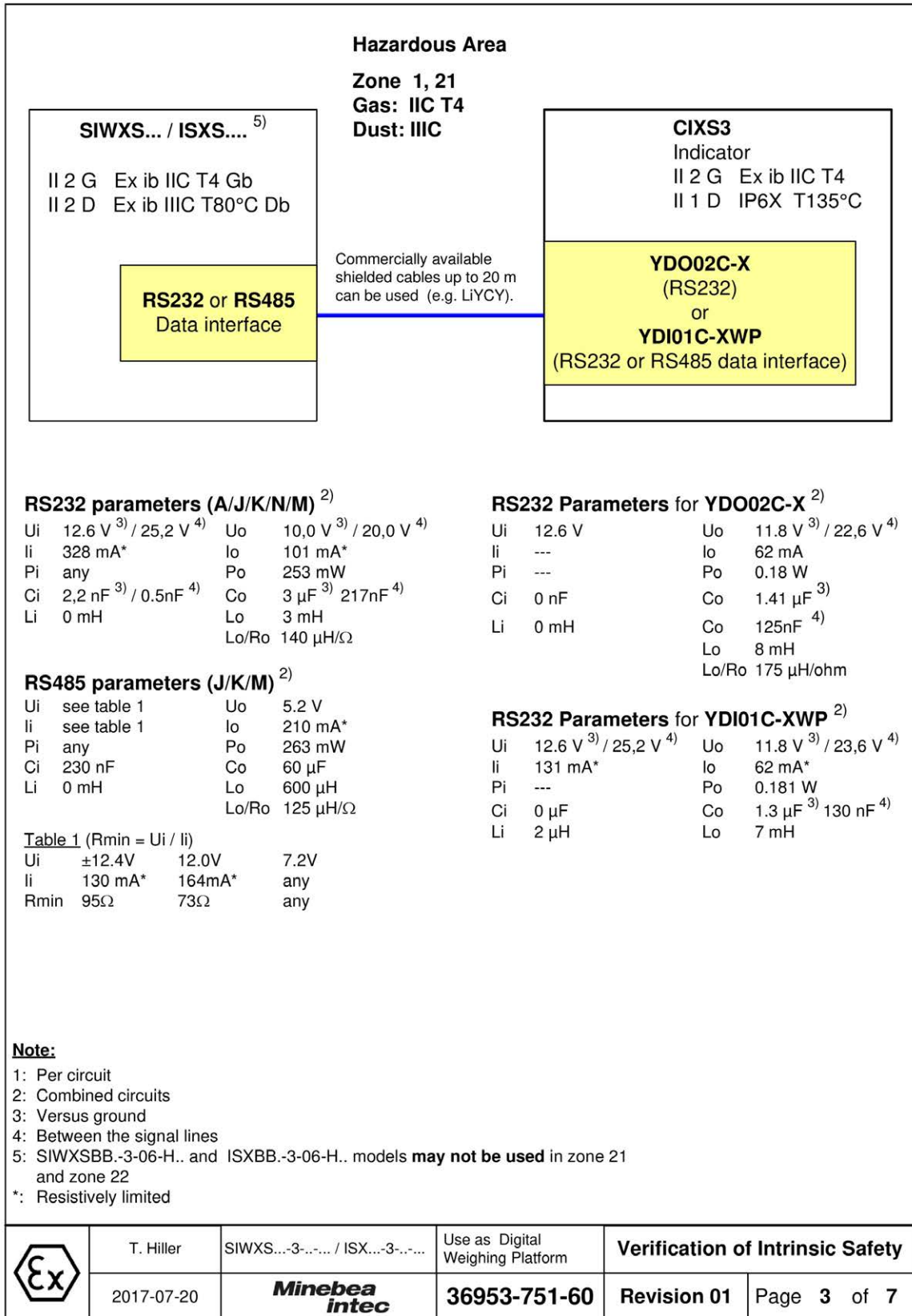

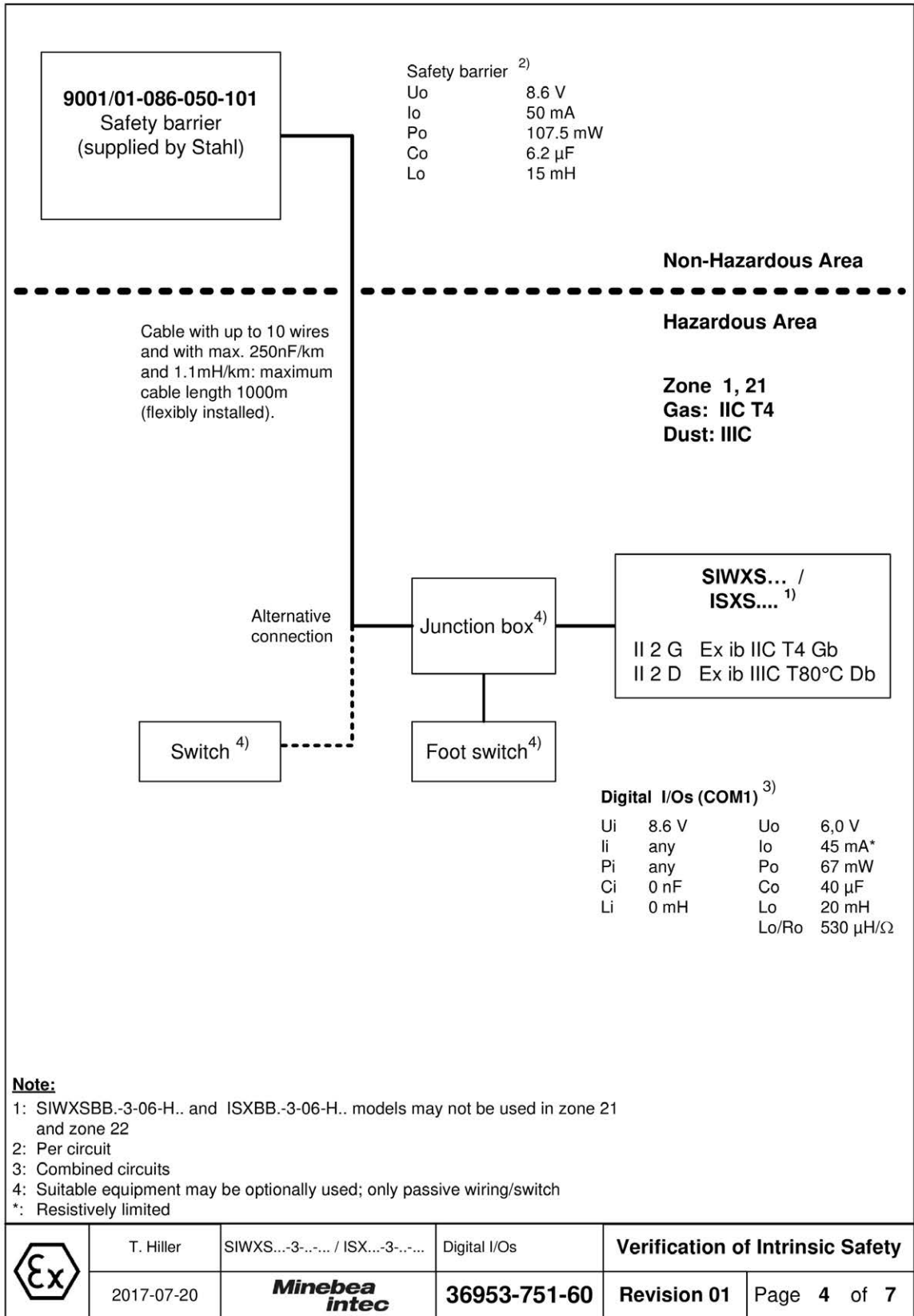

<p>YDI05-Z.. interface converter II (2) GD [EEx ib] IIC <u>or</u></p> <p>Z966 Zener barrier ⁴⁾ in YDI02-Z...: II (2) G [EEx ib] IIC <u>or</u></p> <p>YCO01-Y interface converter II (2) GD [EEx ib] IIC <u>or</u> II 3 (2)GD EEx nR[ib]IIC T4</p>	<p>YDI05-Z.. ²⁾</p> <table border="0"> <tr><td>Uo</td><td>12.4 V*</td><td>Ui</td><td>12.6 V*</td></tr> <tr><td></td><td>24.8 V**</td><td></td><td>25.2 V**</td></tr> <tr><td>Io</td><td>260 mA***</td><td>Ii</td><td>any</td></tr> <tr><td>Po</td><td>800 mW</td><td>Pi</td><td>any</td></tr> <tr><td>Co</td><td>1.24 μF*</td><td>Ci</td><td>0</td></tr> <tr><td></td><td>112 nF**</td><td></td><td></td></tr> <tr><td>Lo</td><td>400 μH*</td><td>Li</td><td>0</td></tr> <tr><td></td><td>400 μH**</td><td></td><td></td></tr> <tr><td>Lo/Ro</td><td colspan="3">44 μH/Ω* / 22 μH/Ω**</td></tr> </table>	Uo	12.4 V*	Ui	12.6 V*		24.8 V**		25.2 V**	Io	260 mA***	Ii	any	Po	800 mW	Pi	any	Co	1.24 μF*	Ci	0		112 nF**			Lo	400 μH*	Li	0		400 μH**			Lo/Ro	44 μH/Ω* / 22 μH/Ω**			<p>Z966 ¹⁾ pins A/J/K/N and M</p> <table border="0"> <tr><td>Uo</td><td>12 V*</td></tr> <tr><td></td><td>24 V**</td></tr> <tr><td>Io</td><td>82 mA / 164 mA ⁵⁾</td></tr> <tr><td>Po</td><td>0.24 W / 0.48 W ⁵⁾</td></tr> <tr><td>Co</td><td>1.41 μF*</td></tr> <tr><td></td><td>125 nF**</td></tr> <tr><td>Lo</td><td>5.52 mH</td></tr> <tr><td></td><td>1.38 mH⁵⁾</td></tr> <tr><td>Lo/Ro</td><td>147 μH/Ω</td></tr> <tr><td></td><td>57 μH/Ω⁵⁾</td></tr> </table>	Uo	12 V*		24 V**	Io	82 mA / 164 mA ⁵⁾	Po	0.24 W / 0.48 W ⁵⁾	Co	1.41 μF*		125 nF**	Lo	5.52 mH		1.38 mH ⁵⁾	Lo/Ro	147 μH/Ω		57 μH/Ω ⁵⁾
Uo	12.4 V*	Ui	12.6 V*																																																							
	24.8 V**		25.2 V**																																																							
Io	260 mA***	Ii	any																																																							
Po	800 mW	Pi	any																																																							
Co	1.24 μF*	Ci	0																																																							
	112 nF**																																																									
Lo	400 μH*	Li	0																																																							
	400 μH**																																																									
Lo/Ro	44 μH/Ω* / 22 μH/Ω**																																																									
Uo	12 V*																																																									
	24 V**																																																									
Io	82 mA / 164 mA ⁵⁾																																																									
Po	0.24 W / 0.48 W ⁵⁾																																																									
Co	1.41 μF*																																																									
	125 nF**																																																									
Lo	5.52 mH																																																									
	1.38 mH ⁵⁾																																																									
Lo/Ro	147 μH/Ω																																																									
	57 μH/Ω ⁵⁾																																																									
<p>RS232 data interface (pins A/J/K/N and M)¹⁾</p> <table border="0"> <tr><td>Ui</td><td>12.6 V</td><td>Uo</td><td>12.6 V</td></tr> <tr><td>Ii</td><td>85 mA</td><td>Io</td><td>28 mA</td></tr> <tr><td>Pi</td><td>270 mW</td><td>Po</td><td>88 mW</td></tr> <tr><td>Ci</td><td>3 nF</td><td>Co</td><td>1.15 μF</td></tr> <tr><td>Li</td><td>0</td><td>Lo</td><td>50 mH</td></tr> </table>	Ui	12.6 V	Uo	12.6 V	Ii	85 mA	Io	28 mA	Pi	270 mW	Po	88 mW	Ci	3 nF	Co	1.15 μF	Li	0	Lo	50 mH	<p>YCO01-Y ²⁾</p> <table border="0"> <tr><td>Uo</td><td>11.8 V*</td><td>Ui</td><td>12.6 V*</td></tr> <tr><td></td><td>23.6V**</td><td></td><td>25.2 V**</td></tr> <tr><td>Io</td><td>123 mA***</td><td>Ii</td><td>131 mA</td></tr> <tr><td>Po</td><td>361 mW</td><td>Pi</td><td>any</td></tr> <tr><td>Co</td><td>1.5 μF*</td><td>Ci</td><td>0.5 nF</td></tr> <tr><td></td><td>129 nF**</td><td></td><td></td></tr> <tr><td>Lo</td><td>2 mH*</td><td>Li</td><td>0.8 μH</td></tr> <tr><td></td><td>2 mH**</td><td></td><td></td></tr> <tr><td>Lo/Ro</td><td colspan="3">98 μH/Ω* / 98μH/Ω**</td></tr> </table>	Uo	11.8 V*	Ui	12.6 V*		23.6V**		25.2 V**	Io	123 mA***	Ii	131 mA	Po	361 mW	Pi	any	Co	1.5 μF*	Ci	0.5 nF		129 nF**			Lo	2 mH*	Li	0.8 μH		2 mH**			Lo/Ro	98 μH/Ω* / 98μH/Ω**			<p>Non-Hazardous Area</p>
Ui	12.6 V	Uo	12.6 V																																																							
Ii	85 mA	Io	28 mA																																																							
Pi	270 mW	Po	88 mW																																																							
Ci	3 nF	Co	1.15 μF																																																							
Li	0	Lo	50 mH																																																							
Uo	11.8 V*	Ui	12.6 V*																																																							
	23.6V**		25.2 V**																																																							
Io	123 mA***	Ii	131 mA																																																							
Po	361 mW	Pi	any																																																							
Co	1.5 μF*	Ci	0.5 nF																																																							
	129 nF**																																																									
Lo	2 mH*	Li	0.8 μH																																																							
	2 mH**																																																									
Lo/Ro	98 μH/Ω* / 98μH/Ω**																																																									
<p>FC/FCA/IS.....-X.. ³⁾ scale / weighing platform (see remark 5 on page 3)</p>	<p>Alternative connection</p>	<p>SIWS... / ISXS... ⁶⁾</p> <p>II 2 G Ex ib IIC T4 Gb II 2 D Ex ib IIIC T80°C Db</p>																																																								
<p>Note:</p>	<p>1: Per circuit 2: Combined circuits 3: Not all models can be used in zones 20,21,22 4: BAS01ATEX7005; II (1) GD [EEx ia] IIC 5: Both channels connected on Z966 6: SIWXSBB.-3-06-H.. and ISXBB.-3-06-H.. models may not be used in zone 21 and zone 22 *: Versus GND; **: Between the lines; ***: Resistively limited</p>	<p>RS232 data interface ²⁾ COM1</p> <table border="0"> <tr><td>Ui</td><td>12.6 V* / 25,2V**</td><td>Uo</td><td>10 V* / 20V**</td></tr> <tr><td>Ii</td><td>328 mA***</td><td>Io</td><td>101 mA***</td></tr> <tr><td>Pi</td><td>any</td><td>Po</td><td>253 mW</td></tr> <tr><td>Ci</td><td>2.2 nF* / 0.5nF**</td><td>Co</td><td>3 μF* / 217nF**</td></tr> <tr><td>Li</td><td>0 mH</td><td>Lo</td><td>3 mH</td></tr> <tr><td></td><td></td><td>Lo/Ro</td><td>140 μH/Ω</td></tr> </table>	Ui	12.6 V* / 25,2V**	Uo	10 V* / 20V**	Ii	328 mA***	Io	101 mA***	Pi	any	Po	253 mW	Ci	2.2 nF* / 0.5nF**	Co	3 μF* / 217nF**	Li	0 mH	Lo	3 mH			Lo/Ro	140 μH/Ω																																
Ui	12.6 V* / 25,2V**	Uo	10 V* / 20V**																																																							
Ii	328 mA***	Io	101 mA***																																																							
Pi	any	Po	253 mW																																																							
Ci	2.2 nF* / 0.5nF**	Co	3 μF* / 217nF**																																																							
Li	0 mH	Lo	3 mH																																																							
		Lo/Ro	140 μH/Ω																																																							
	<p>T. Hiller 2017-07-20</p>	<p>SIWXS...-3-... / ISX...-3-... Minebea intec</p>	<p>RS232 Data Interface 36953-751-60</p>	<p>Verification of Intrinsic Safety Revision 01 Page 5 of 7</p>																																																						

<p>YDI05-Z.. interface converter II (2) GD [EEx ib] IIC <u>or</u></p> <p>Z966 Zener barrier ⁴⁾ in YDI02-Z...: II (2) G [EEx ib] IIC <u>or</u></p> <p>YCO01-Y interface converter II (2) GD [EEx ib] IIC <u>or</u> II 3 (2)GD EEx nR[ib]IIC T4</p>	<p>YDI05-Z.. ^{2) 7)}</p> <table border="0"> <tr> <td>Uo</td><td>12.4 V*</td><td>Ui</td><td>12.6 V*</td></tr> <tr> <td></td><td>24.8V**</td><td></td><td>25.2</td></tr> <tr> <td colspan="4">V**</td> </tr> <tr> <td>Io</td><td>130 mA***</td><td>Ii</td><td>any</td></tr> <tr> <td>Po</td><td>400 mW</td><td>Pi</td><td>any</td></tr> <tr> <td>Co</td><td>1.24 μF*</td><td>Ci</td><td>0</td></tr> <tr> <td></td><td>112nF**</td><td></td><td></td></tr> <tr> <td>Lo</td><td>0.4 mH*</td><td>Li</td><td>0</td></tr> <tr> <td></td><td>0.4 mH**</td><td></td><td></td></tr> <tr> <td>Lo/Ro</td><td colspan="3">44 μH/Ω* / 22 μH/Ω**</td></tr> </table>	Uo	12.4 V*	Ui	12.6 V*		24.8V**		25.2	V**				Io	130 mA***	Ii	any	Po	400 mW	Pi	any	Co	1.24 μF*	Ci	0		112nF**			Lo	0.4 mH*	Li	0		0.4 mH**			Lo/Ro	44 μH/Ω* / 22 μH/Ω**			<p>Z966 ¹⁾ pins A/J/K/N and M</p> <table border="0"> <tr> <td>Uo</td><td>12 V*</td></tr> <tr> <td></td><td>24V**</td></tr> <tr> <td>Io</td><td>82 mA /164mA ⁶⁾</td></tr> <tr> <td>Po</td><td>0.24 W / 0.48W ⁶⁾</td></tr> <tr> <td>Co</td><td>1.41 μF*</td></tr> <tr> <td></td><td>125nF**</td></tr> <tr> <td>Lo</td><td>5.52 mH</td></tr> <tr> <td></td><td>1.38mH ⁶⁾</td></tr> <tr> <td>Lo/Ro</td><td>147 μH/Ω</td></tr> <tr> <td></td><td>57 μH/Ω ⁶⁾</td></tr> </table>	Uo	12 V*		24V**	Io	82 mA /164mA ⁶⁾	Po	0.24 W / 0.48W ⁶⁾	Co	1.41 μF*		125nF**	Lo	5.52 mH		1.38mH ⁶⁾	Lo/Ro	147 μH/Ω		57 μH/Ω ⁶⁾
Uo	12.4 V*	Ui	12.6 V*																																																											
	24.8V**		25.2																																																											
V**																																																														
Io	130 mA***	Ii	any																																																											
Po	400 mW	Pi	any																																																											
Co	1.24 μF*	Ci	0																																																											
	112nF**																																																													
Lo	0.4 mH*	Li	0																																																											
	0.4 mH**																																																													
Lo/Ro	44 μH/Ω* / 22 μH/Ω**																																																													
Uo	12 V*																																																													
	24V**																																																													
Io	82 mA /164mA ⁶⁾																																																													
Po	0.24 W / 0.48W ⁶⁾																																																													
Co	1.41 μF*																																																													
	125nF**																																																													
Lo	5.52 mH																																																													
	1.38mH ⁶⁾																																																													
Lo/Ro	147 μH/Ω																																																													
	57 μH/Ω ⁶⁾																																																													
<p>Data cable: <u>Recommended:</u> Sartorius cable YCC485-X with approx. 10μH/ohm and 120pF/m (wire/wire) up to 1000m flexibly installed.</p>	<p>YCO01-Y ²⁾</p> <table border="0"> <tr> <td>Uo</td><td>7.2 V*</td><td>Ui</td><td>12.6 V*</td></tr> <tr> <td></td><td>8.0 V**</td><td></td><td>25.2 V**</td></tr> <tr> <td>Io</td><td>207 mA***</td><td>Ii</td><td>1.5 A</td></tr> <tr> <td>Po</td><td>330 mW</td><td>Pi</td><td>2.5 W</td></tr> <tr> <td>Co</td><td>13.5 μF*</td><td>Ci</td><td>1 nF</td></tr> <tr> <td></td><td>8.4 μF**</td><td></td><td></td></tr> <tr> <td>Lo</td><td>0.7 mH*</td><td>Li</td><td>1.6 μH</td></tr> <tr> <td></td><td>0.7 mH**</td><td></td><td></td></tr> <tr> <td>Lo/Ro</td><td colspan="3">36 μH/Ω* / 36μH/Ω**</td></tr> </table>	Uo	7.2 V*	Ui	12.6 V*		8.0 V**		25.2 V**	Io	207 mA***	Ii	1.5 A	Po	330 mW	Pi	2.5 W	Co	13.5 μF*	Ci	1 nF		8.4 μF**			Lo	0.7 mH*	Li	1.6 μH		0.7 mH**			Lo/Ro	36 μH/Ω* / 36μH/Ω**			<p>Non-Hazardous Area</p>																								
Uo	7.2 V*	Ui	12.6 V*																																																											
	8.0 V**		25.2 V**																																																											
Io	207 mA***	Ii	1.5 A																																																											
Po	330 mW	Pi	2.5 W																																																											
Co	13.5 μF*	Ci	1 nF																																																											
	8.4 μF**																																																													
Lo	0.7 mH*	Li	1.6 μH																																																											
	0.7 mH**																																																													
Lo/Ro	36 μH/Ω* / 36μH/Ω**																																																													
<p>RS485 data interface ^{5) 2)} (UNICOM. LV2)</p> <table border="0"> <tr> <td>Uo</td><td>7.2 V</td><td>Ui</td><td>12.6 V</td></tr> <tr> <td>Io</td><td>127 mA*</td><td>Ii</td><td>1.5 A*</td></tr> <tr> <td>Po</td><td>0.273 W</td><td>Pi</td><td>2.5 W</td></tr> <tr> <td>Co</td><td>11.3 μF</td><td>Ci</td><td>0</td></tr> <tr> <td>Lo</td><td>2 mH</td><td>Li</td><td>2 μH</td></tr> <tr> <td>Lo/Ro</td><td colspan="3">130 μH/Ω</td></tr> </table>	Uo	7.2 V	Ui	12.6 V	Io	127 mA*	Ii	1.5 A*	Po	0.273 W	Pi	2.5 W	Co	11.3 μF	Ci	0	Lo	2 mH	Li	2 μH	Lo/Ro	130 μH/Ω			<p>Zone 1, 21 Gas: IIC T4 Dust: IIIC</p>	<p>Hazardous Area</p>																																				
Uo	7.2 V	Ui	12.6 V																																																											
Io	127 mA*	Ii	1.5 A*																																																											
Po	0.273 W	Pi	2.5 W																																																											
Co	11.3 μF	Ci	0																																																											
Lo	2 mH	Li	2 μH																																																											
Lo/Ro	130 μH/Ω																																																													
<p>RS485 data interface ^{5) 2)} (LV4)</p> <table border="0"> <tr> <td>Uo</td><td>7.2 V ³⁾</td><td>Ui</td><td>12.6 V</td></tr> <tr> <td></td><td>8.2 V ⁴⁾</td><td></td><td></td></tr> <tr> <td>Io</td><td>168 mA*</td><td>Ii</td><td>1.5 A*</td></tr> <tr> <td>Po</td><td>0.25 W</td><td>Pi</td><td>2.5 W</td></tr> <tr> <td>Co</td><td>13 μF ³⁾</td><td>Ci</td><td>300 nF ³⁾</td></tr> <tr> <td>Co</td><td>7.6 μF ⁴⁾</td><td>Ci</td><td>100 nF ⁴⁾</td></tr> <tr> <td>Lo</td><td>0.8 mH</td><td>Li</td><td>0 mH</td></tr> <tr> <td>Lo/Ro</td><td colspan="3">118 μH/Ω</td></tr> </table>	Uo	7.2 V ³⁾	Ui	12.6 V		8.2 V ⁴⁾			Io	168 mA*	Ii	1.5 A*	Po	0.25 W	Pi	2.5 W	Co	13 μF ³⁾	Ci	300 nF ³⁾	Co	7.6 μF ⁴⁾	Ci	100 nF ⁴⁾	Lo	0.8 mH	Li	0 mH	Lo/Ro	118 μH/Ω			<p>Up to 7 additional CIXS3 or SIWS... / ISXS... ³⁾</p>	<p>SIWS... / ISXS... ³⁾</p> <p>II 2 G Ex ib IIC T4 Gb II 2 D Ex ib IIIC T80°C Db</p>																												
Uo	7.2 V ³⁾	Ui	12.6 V																																																											
	8.2 V ⁴⁾																																																													
Io	168 mA*	Ii	1.5 A*																																																											
Po	0.25 W	Pi	2.5 W																																																											
Co	13 μF ³⁾	Ci	300 nF ³⁾																																																											
Co	7.6 μF ⁴⁾	Ci	100 nF ⁴⁾																																																											
Lo	0.8 mH	Li	0 mH																																																											
Lo/Ro	118 μH/Ω																																																													
<p>Note:</p> <ol style="list-style-type: none"> Per circuit Combined circuits SIWSBB.-3-06-H.. and ISXBB.-3-06-H.. models may not be used in zone 21 and zone 22 BAS01ATEX7005; II (1) GD [EEx ia] IIC Data for CIXS3 Both channels connected on Z966 Only 2 RS232 connections are used on the YDI05-Z <p>*: Versus GND; **: Between the lines; ***: Resistively limited</p>	<p>RS485 data interface ²⁾</p> <table border="0"> <tr> <td>Ui</td><td>see below</td><td>Uo</td><td>5.2 V</td></tr> <tr> <td>Ii</td><td>see below</td><td>Io</td><td>210 mA***</td></tr> <tr> <td>Pi</td><td>any</td><td>Po</td><td>263 mW</td></tr> <tr> <td>Ci</td><td>230 nF</td><td>Co</td><td>60 μF</td></tr> <tr> <td>Li</td><td>0 mH</td><td>Lo</td><td>600 μH</td></tr> <tr> <td></td><td></td><td>Lo/Ro</td><td>125 μH/Ω</td></tr> </table> <table border="0"> <tr> <td>Ui</td><td>±12.4V</td><td>12.0V</td><td>7.2V</td></tr> <tr> <td>Ii</td><td>130 mA***</td><td>164mA***</td><td>any</td></tr> </table>	Ui	see below	Uo	5.2 V	Ii	see below	Io	210 mA***	Pi	any	Po	263 mW	Ci	230 nF	Co	60 μF	Li	0 mH	Lo	600 μH			Lo/Ro	125 μH/Ω	Ui	±12.4V	12.0V	7.2V	Ii	130 mA***	164mA***	any																													
Ui	see below	Uo	5.2 V																																																											
Ii	see below	Io	210 mA***																																																											
Pi	any	Po	263 mW																																																											
Ci	230 nF	Co	60 μF																																																											
Li	0 mH	Lo	600 μH																																																											
		Lo/Ro	125 μH/Ω																																																											
Ui	±12.4V	12.0V	7.2V																																																											
Ii	130 mA***	164mA***	any																																																											
	<p>T. Hiller 2017-07-20</p>	<p>SIWS...-3-... / ISX...-3-...-... Minebea Intec</p>	<p>RS485 Data Interface 36953-751-60</p>	<p>Verification of Intrinsic Safety Revision 01 Page 6 of 7</p>																																																										

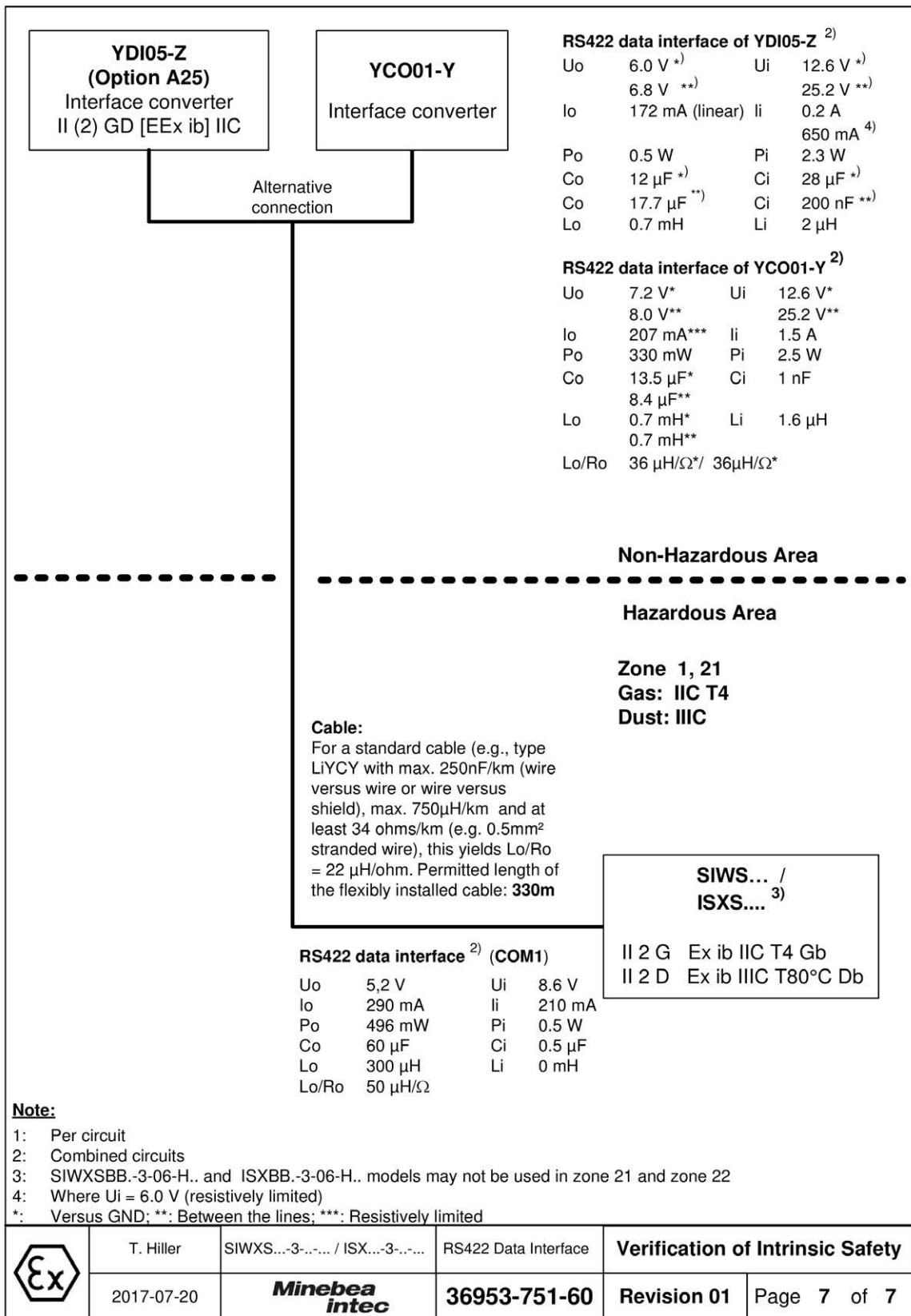

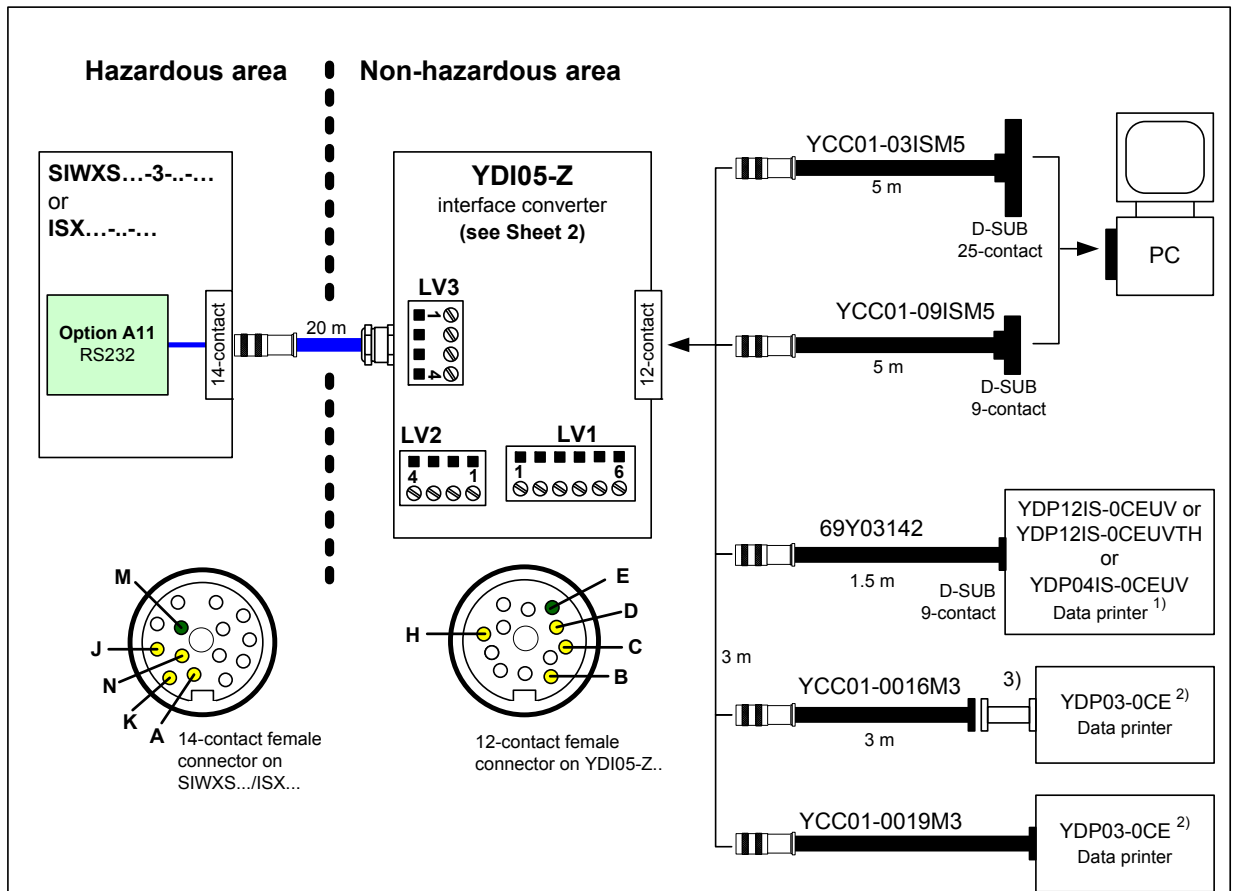

	14-contact		LV2	LV1	or	12-contact	25-contact ⁴⁾	9-contact	
TxD	K	yellow	4	4		B	3	2	RxD
DTR	N	green	3	3		D	5	8	CTS
RxD	J	white	1	1		C	2	3	TxD
CTS	A	brown	2	2		H	20	4	DTR
Signal_GND	M	gray	1 (LV3)	5		E	7	5	

Important note!

Max. voltage V_m of any electrical apparatus connected to the interface converter type YDI05-Z.. may not exceed 250V. The internal Zener voltage V_z is 12.6V.

Note:

- 1: External power supply is included in the scope of delivery.
- 2: External power supply is necessary (not in the scope of delivery).
- 3: Cable is included in the scope of delivery.
- 4: Pin 1 = shield (housing)

	2013-02-02	RS-232 (EX) - RS-232 (Non-EX) connections		Title	Data Transfer	Page 1 of 6
	Dr. D. Klausgrete			Drawing number	36953-751-40	Revision 00

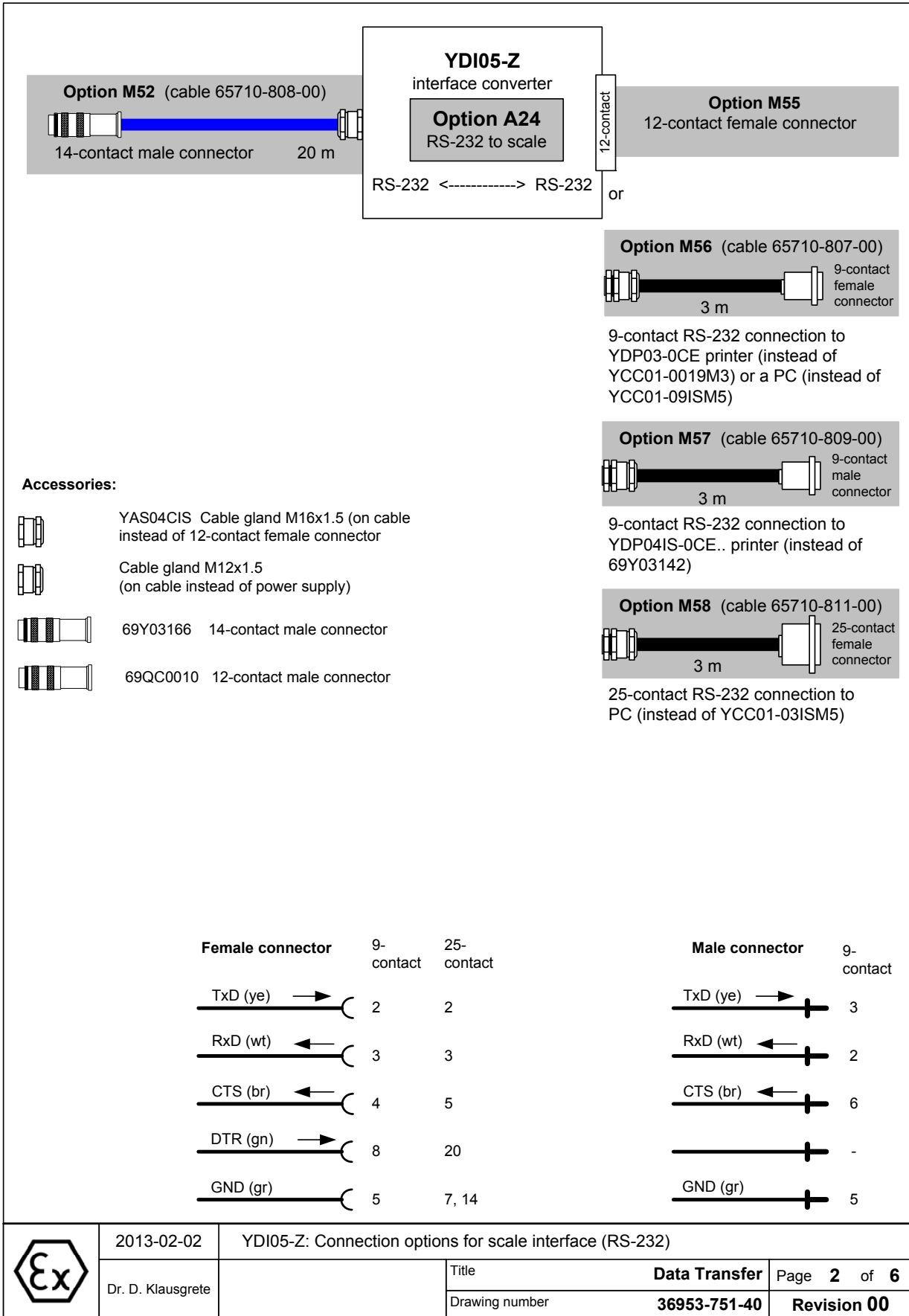

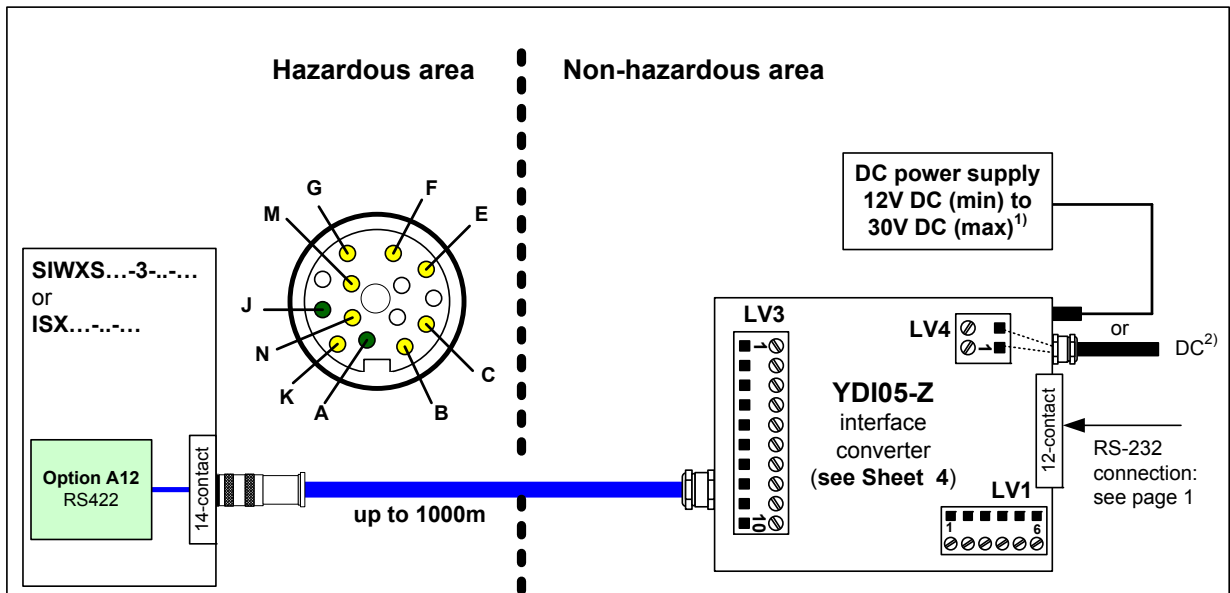

	14- contact		LV3		LV1 or 12- contact
TxD+	N	green	9	RxD+	4
TxD-	K	yellow	10	RxD-	B
RxD+	G	pink	7	TxD+	1
RxD-	M	gray	8	TxD-	C
DTR+	C	violet	5	CTS+	3
DTR-	B	black	6	CTS-	D
CTS+	F	red	3	DTR+	2
CTS-	E	blue	4	DTR-	H
Signal_GND	A, J	brown, white	1, 2	Signal_GND	5

Important note!

Max. voltage V_m of any electrical apparatus connected to the interface converter type YDI05-Z.. may not exceed 250V. The internal Zener voltage V_z is 12.6V.

Note:

- 1: External power supply (e.g. type 6971991 in the scope of delivery).
- 2: DC power supply: 12 to 30 V; positive voltage on Pin 1 of LV4; order cable and cable gland separately

	2013-02-02	RS-422 (EX) - RS-232 (Non-EX) connection	Title	Data Transfer	Page 3 of 6
	Dr. D. Klausgrete		Drawing number	36953-751-40	Revision 00

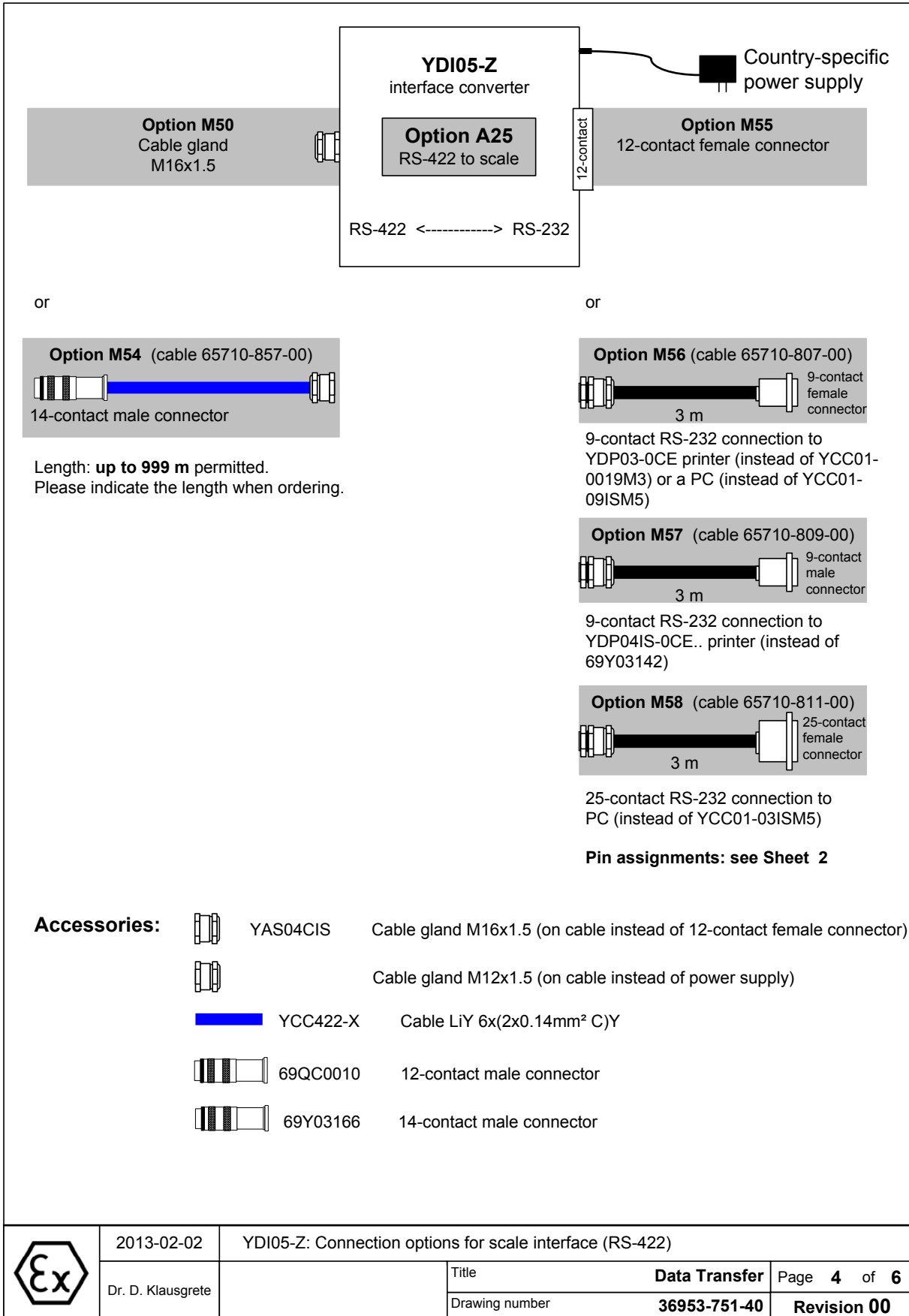

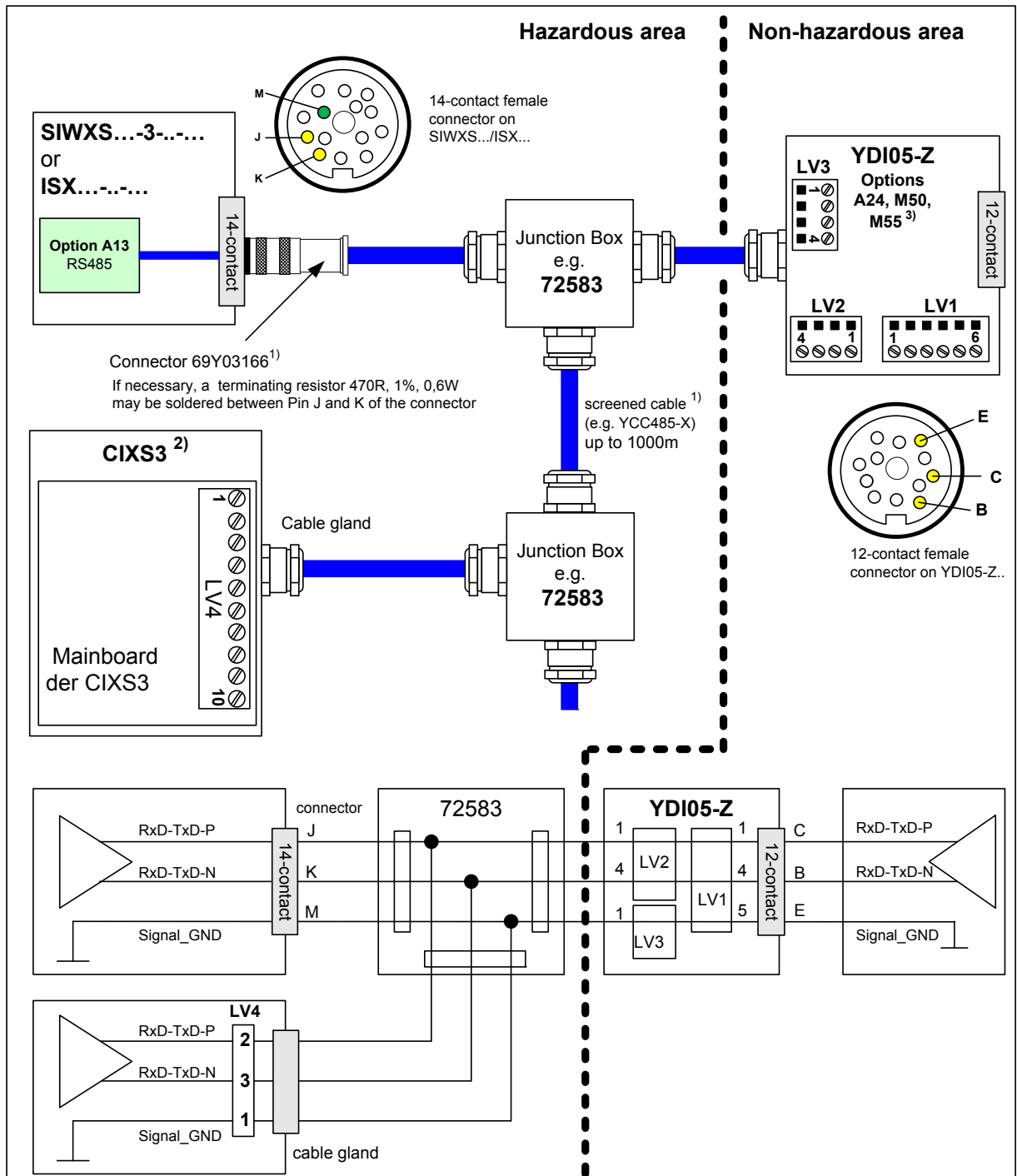

Connector 69Y03166¹⁾
 If necessary, a terminating resistor 470R, 1%, 0,6W may be soldered between Pin J and K of the connector

CIXS3²⁾

screened cable¹⁾
 (e.g. YCC485-X)
 up to 1000m

Important note!
 Max. voltage V_m of any electrical apparatus connected to the interface converter type YDI05-Z.. may not exceed 250V. The internal Zener voltage V_z is 12.6V.

- Note:**
- 1: not in the scope of delivery
 - 2: up to 8 devices; see „Verification of Intrinsic safety“ (in the manual of these devices)
 - 3: A cable can be rooted directly into the housing via cable gland YAS04CIS instead of using the 12-contact connector (Option M58).

	2013-02-02	RS485 connection with YDI05-Z	Title	Data Transfer	Page 5 of 6
	Dr. D. Klausgrete		Drawing number	36953-751-40	Revision 00

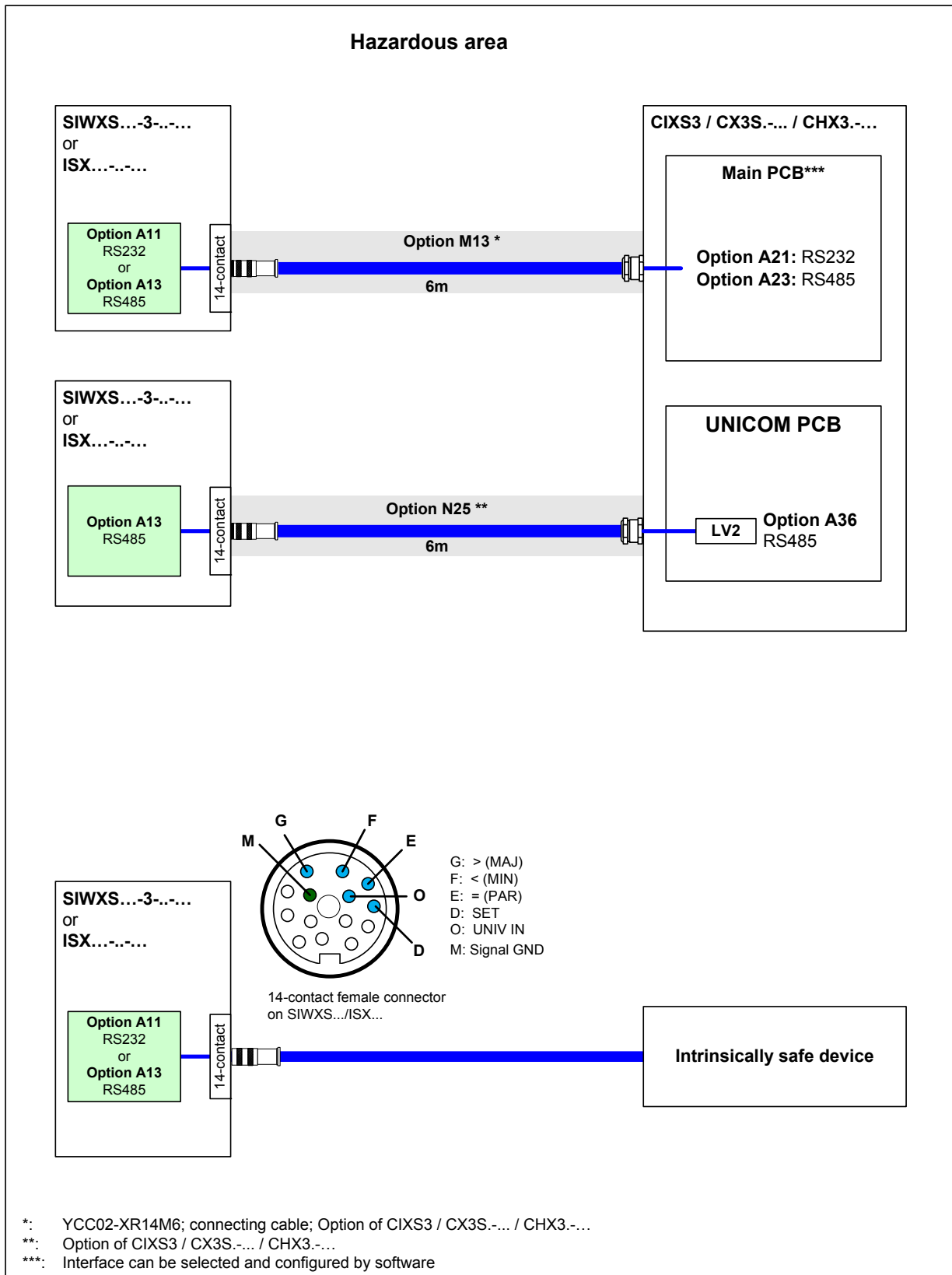

	2013-02-02	Digital IOs	Title	Data Transfer	Page 6 of 6
	Dr. D. Klausgrete		Drawing number	36953-751-40	Revision 00

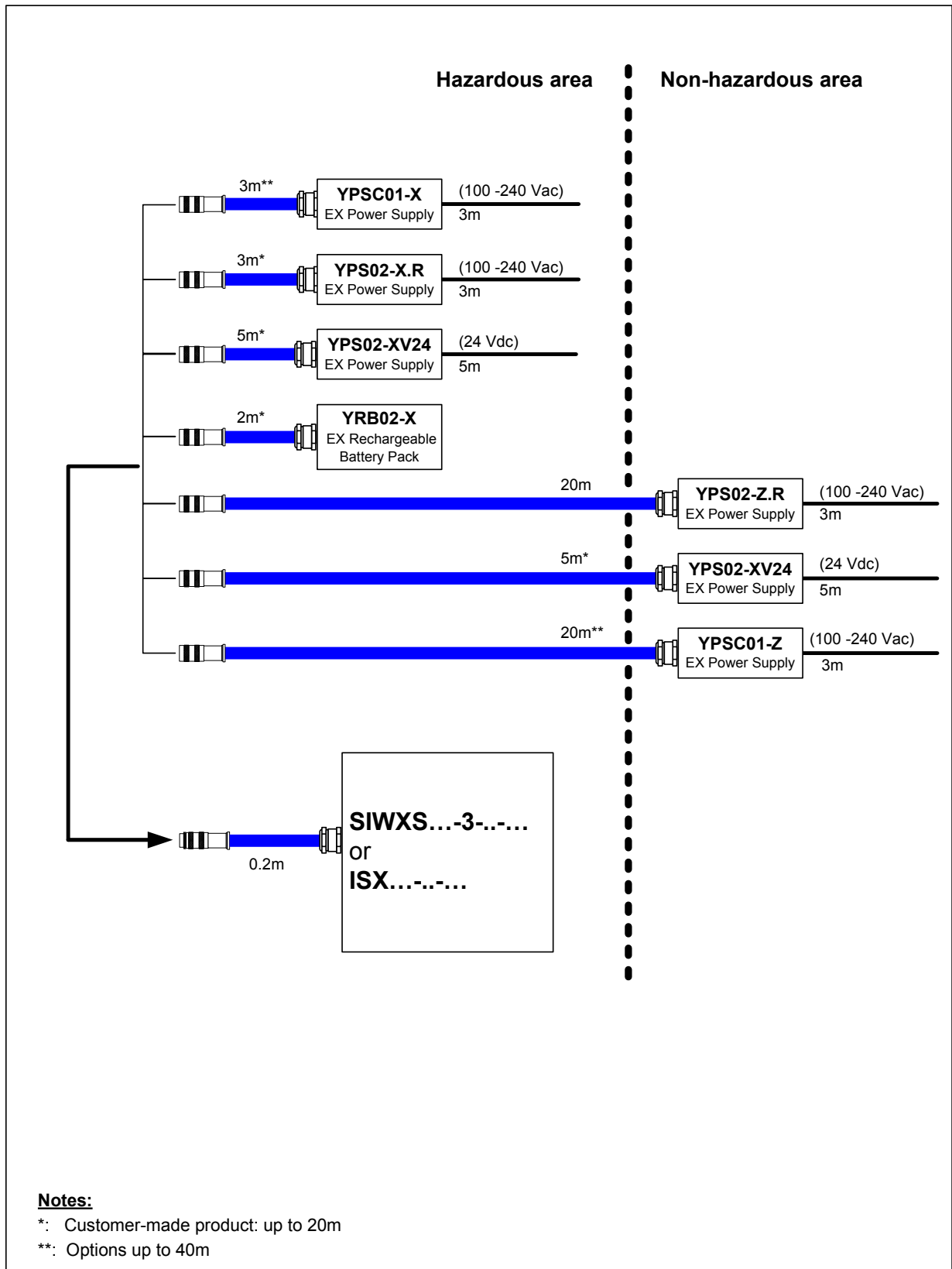

Notes:

*: Customer-made product: up to 20m

**.: Options up to 40m



2013-02-02

Dr. D. Klausgrete

Title

Power Supply

Page **1** of **1**

Drawing number

36953-751-50

Revision 00

These safety instructions apply to the installation, operation, maintenance and repair of the equipment

- 1) Install the equipment in compliance with applicable laws, rules and regulations, ordinances and standards. In particular, be sure to conform to the European Standards EN 60079-14 (Explosive atmospheres – Part 14: Electrical installations design, selection and erection). For more information see „Verification of Intrinsic Safety“ 36953-751-60 (ATEX) and „Control Drawing“ 36953-751-07 (for use in the USA and in Canada).
- 2) Be sure to follow the installation, operating, maintenance and servicing instructions given in the manuals supplied.
- 3) The equipment shall be installed in such a way that it is protected against the entry of solid foreign objects or water capable of impairing the safety of the apparatus. Reduce the risk of mechanical damage to a minimum.
- 4) The equipment must be powered by a suitable certified/approved power supply / battery pack with intrinsically safe circuits as described in the certificate of this equipment.
- 5) Exposure to UV radiation is not allowed!
- 6) The connecting cable of the display unit must be prevented against damage and stress caused by strain.
- 7) Prior to opening the equipment, disconnect the power supply or make sure that there is no potentially explosive atmosphere or any other explosion hazard in the surrounding area!
- 8) The data cable connected to the equipment is considered as intrinsically safe circuit. The connection is secured against accidental disconnection and may only be plugged in or disconnected when the power is switched completely off. Output not used must be safeguarded by appropriate sealing cap so that the IP protection rating is maintained. Check the correct function of the data transfer before you use the equipment in a hazardous location.
- 9) If the equipment does not operate properly, unplug it immediately from line power (mains supply)!
- 10) All metal parts must be electrically connected to the terminal for the equipotential bonding conductor (PA). The equipment operator is obligated to connect a lead with a gauge of at least 4 mm² (cross section) to the PA terminal located on the side of the housing. The low resistance of this connection to the PA busbar must be checked when the system is installed at the intended place of use. The shielding of the connecting cables may only be used for grounding when no impermissible difference in voltage is generated and, if necessary, the shielding is able to conduct the equipotential current.
- 11) Avoid generating static electricity. Use only a damp cloth to wipe down the equipment. The equipment operator shall be responsible for preventing any risks caused by static electricity.
- 12) Keep chemicals and other agents, which can corrode the housing seals and cable sheaths, away from the equipment. These agents include oil, grease, benzene, acetone and ozone. If you are not sure about the safety of a certain substance, please contact the manufacturer.
- 13) Use equipment only in the temperature ranges indicated. Avoid exposing the equipment to heat.
- 14) The equipment operator is responsible for any non-Sartorius cables used.
- 15) Check the EX approval marking (particularly the group for gases/dusts and temperature class/code) on all equipment in the hazardous area before operation to ensure that this approved equipment is permitted to be operated in this area.
- 16) At reasonable intervals, have your equipment installation checked for proper functioning and safety by a trained and certified technician.
- 17) If your equipment needs to be repaired, use only original spare parts supplied by the manufacturer!
- 18) Any tampering with the equipment by anyone, other than repair work done by authorized Sartorius service technicians, will result in the loss of EX conformity and in the forfeiture of all claims under the manufacturer's warranty. Only authorized specialists may open the equipment.
- 19) Modifications, including those to be carried out by Sartorius employees, may be permitted only after the express written authorization has been obtained from Sartorius.
- 20) If an IP6x housing has been opened, replace the gasket and close the housing with a tightening torque of 1 Nm. The screws, which are used to close the data output sheets, must be secured with a tightening torque of 2 Nm.

	2012-10-18	Safety Instructions	Page 1 of 1
	Dr. D. Klausgrete		Drawing number 36953-751-16 Revision 00

Appendix: General Password



Press repeatedly **Fn**, **→T←**;

Press repeatedly **Fn**, **→T←**;

Press repeatedly **Fn**, **→T←**;

Press repeatedly **Fn**, **→T←**;

Press repeatedly **Fn**, **→T←**;

Press repeatedly **Fn**, **→T←**;

Press repeatedly **Fn**, **→T←**;

Press repeatedly **Fn**, **→T←**;



→T← (press and hold)



After selecting the "Setup" menu item a request to enter the access password "Code" will be shown on the display for 2 seconds.

The place for the first character of the password flashes.

- Enter password
 - Enter the numbers with the **Fn** key and save with the **→T←** key.
 - Press the **Fn** key (numbers in ascending order: 0-9) or the **↵** key (numbers in descending order: 9-1) until the required character appears on the display.
 - If the password is longer than 7 characters the first character will be displaced to the right and out of the display.

The password set is shown on the display.

Confirm the password

Exit from the menu level

Save settings and exit menu

General password:
40414243

Service password:
202122

Minebea Intec Bovenden GmbH & Co. KG
Leinetal 2
37120 Bovenden, Germany

Phone +49 (0)5 51.309.83.0
Fax +49 (0)5 51.309.83.190

www.minebea-intec.com

Copyright by Minebea Intec,
Bovenden, Germany.

No part of this publication may be reprinted
or translated in any form or by any means
without prior written permission from
Minebea Intec.

All rights reserved by Minebea Intec in
accordance with copyright law.

The information and figures contained
in these instructions correspond to the
version date specified below. Minebea Intec
reserves the right to make changes to the
technology, features, specifications, and
design of the equipment without notice.

Date: October 2018

Printed in Germany.
Printed on bleached, chlorine-free paper
KT - RS
Publication No.: WSI6011-e18107