

Ishida WM-Micro

Compact Wrapper



FEATURES

- Process up to 15 packages per minute with manual tray selection
- Quick film loading
- Compact, space-saving design fits almost anywhere
- Wraps most trays between #2 and #25
- High-capacity label roll with two times the length of a standard roll
- Fixed high-capacity side-load cassette
- High-resolution printhead
- Prints safe handling instructions, country of origin, 2020 nutrition, custom text messages, custom images and more
- Dynamically generated QR code printing
- Large customizable color touchscreen with adjustable viewing angle and tactile keypad
- Assign color images to preset keys
- Display videos with sound
- PC-based with a solid-state drive for speed and reliability
- Secure remote access
- Filter for third-party driver communication
- Modes: Wrap and Label, Wrap, Label
- Fully compliant with RoHS regulations for a completely lead-free machine
- Optional Wi-Fi kit (factory installation recommended)
- Linerless model available with auto cutter
- Compatible with third-party software, including Upshop 360°, ADC's InterScale®, Invafresh's ePlum®, Toast®, Square® and Droste®



WM-Micro operator screen



SPECIFICATIONS

Power:

200 to 240V (1-phase)
Standard 20 A circuit

Power Consumption:

In operation: 1,200 W or less
Standby: 1,000 W or less

Resolution:

3,000 display divisions maximum

Communications:

LAN
Static/DHCP
Optional Wi-Fi 802.11a/b/g/n/ac
2.4 GHz/5 GHz
Security: WEP/WPA/WPA2

Input/Output:

LAN
Four USB-A (service, transaction data)

Operating System:

Linux

Memory Capacity:

SSD 1 GB

Preset Keys:

99 dynamically programmed groups
with 99 sub pages
19 tactile function keys

Display:

Operator: resistive thin film
analogue touch panel, TFT LCD
color touchscreen with LED backlight
with SVGA, 12.1 in (800 × 600 px)
Unit price: six digits
Tare: four digits
Weight: five digits
Total price: eight digits

Printer:

Printhead: 3.1 in (80 mm)
direct thermal, effective 3 in (76mm)
Resolution: 300 dpi (12 dot/mm)
Speed: 4.7 in/sec (120 mm/sec) max
Min. weight: 0.015 lb (0.006 kg)
Formats: customizable, up to 999
Barcodes: UPC, JAN, EAN, EAN128,
CODE128, ITF, GS1, QR, Custom

Label Size:

Type: Die-cut, continuous,
optional linerless label with kit
Width (with liner):
1.1 to 3.1 in (30 to 80 mm)
Width (linerless):
1 to 3 in (23 to 76 mm)
Length (with liner):
0.9 to 4.1 in (23 to 105 mm)
Length (linerless):
1.1 to 19.6 in (30 to 500 mm)

Label Roll :

I.D.: 1.6-in (40 mm) min
O.D.: 4.9-in (125 mm) max
Backing width: 3.2-in (82 mm) max

Wrapping:

Weigh and wrap:
15 packages per minute max
Width: 5.9 to 15.0 in (150 × 381 mm)
Depth: 5.0 to 9.6 in (127 × 244 mm)
Height: 0.4 to 5.1 in (10 × 130 mm)
Tray height: 1.7-in (45 mm) max
Weight: 0.015 lb (0.006 kg) to
7.7 lb (3.5 kg)
Tray material: Polystyrene Paper (PSP),
Polypropylene (PP), Polyethylene
Terephthalate (PET)

Film:

Type: PVC, PO, PE
Rolls: One, manual film selection
Length: 5,000 ft (1,524 m)
Width: 400 to 550 mm
O.D.: 7.9 in (200 mm)
Recommended: Mitsubishi A50

Platter:

13.5 × 10 in (343 × 254 mm)

Weight:

Liner: approx. 283.7 lb (128.5 kg)
Linerless: approx. 286.0 lb (129.8 kg)

Temperature:

Operating: 41 °F to 95 °F (5 °C to 35 °C)

Humidity:

20 to 85% RH (without condensation)

Noise:

73 to 75 dB

Warranty:

One-year limited
Based on volume of 900 packs per day
using Mitsubishi film

Approvals:

NTEP 06-029
cULus Listed



PART NUMBER/PRICE

PART #	MODEL/DESCRIPTION	SINGLE-RANGE CAPACITY	DUAL-RANGE CAPACITY	EST. SHIP WEIGHT	PRICE
223814	WM-Micro, manual label	0 to 30 × 0.01 lb	0 to 15 × 0.005 lb / 15 to 30 × 0.01 lb	325 lb	Consult
226173	WM-Micro, linerless label with auto cutter	0 to 30 × 0.01 lb	0 to 15 × 0.005 lb / 15 to 30 × 0.01 lb	340 lb	Consult

Ishida WM-Micro

Compact Wrapper

OPTIONS/ACCESSORIES

PART #	DESCRIPTION	PRICE
121076	Stand, stainless steel with leveling legs, casters, 28 × 26 × 27 in (W × D × H)	Consult
125578	Day Glow label dispenser, 25-3/4 × 7-5/8 in aluminum, 20 roll capacity includes the arms that mount the Day Glow dispenser to the stand (PN 121076)	Consult
151761	Day Glow label dispenser spacer, pack of ten	Consult
121077	Plastic washdown cover, short for use with WM-Micro on optional stand	Consult
125417	Plastic washdown cover, tall for use with Day Glow label dispenser and optional stand	Consult
226175	Film Roll Protection Cover, stainless steel	Consult
225984	WM-Micro floor mat template, 35 in x 40 in	Consult
95540	Service key, door safety interlocks	Consult
160906	USB flash memory, 1 GB	Consult

COMMUNICATION

PART #	DESCRIPTION	PRICE
226174	Internal wireless communication 802.11a/b/g/n/ac 2.4 GHz/5 GHz (factory installation recommended)	Consult
152628*	ScaleLink Pro 5 license file, one license required per computer (version 2.63 or higher required)	Consult
78860	Cross cable, Ethernet CAT5, 6 ft	Consult

*Software key is provided after purchase and online registration is completed at www.ricelake.com/ishida-software-form

NOTE: Manuals and software programs can be downloaded from the distributor section of www.ricelake.com/retail

WM-Micro Series Financial Terms and Conditions

Our financial services group reviews open account requests. Upon approval of open account terms, orders may be subject to the following payment terms:
20% down with the order.

WRAPPING FILM

PART #	DESCRIPTION	EST. SHIP WEIGHT	PRICE
181916	400 mm × 1,000 m (15.7 in × 3,280 ft) one box of two rolls	28 lb	Consult
187821	450 mm × 1,000 m (17.7 in × 3,280 ft) one box of two rolls	35 lb	Consult
170110	500 mm × 1,000 m (19.7 in × 3,280 ft) one box of two rolls	38 lb	Consult

DIMENSIONS

Bench			
A	31.5 in (800 mm) 32.4 in (823 mm) linerless	E	34.1 in (866 mm)
B	33.5 in (851 mm)	F	29.8 in (757 mm)
C	28.9 in (734 mm)	G	12.2 in (310 mm)
D	29.1 in (739 mm)	H	16.7 in (424 mm)

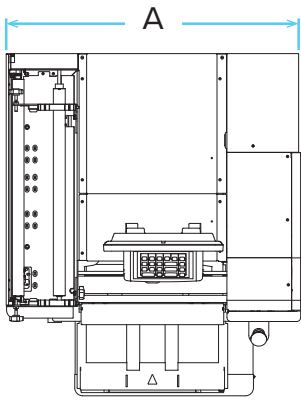

Top

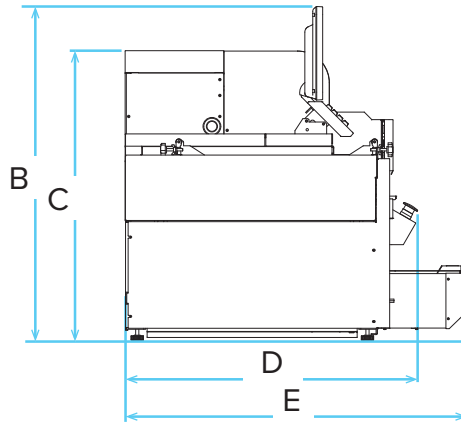

Left Side

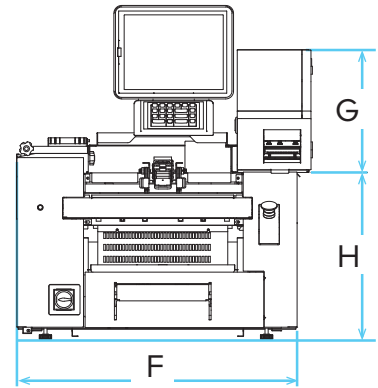

Front

DIMENSIONS

Bench			
A	26.30 in (668 mm)	C	28.00 in (711 mm)
B	26.00 in (660 mm)		

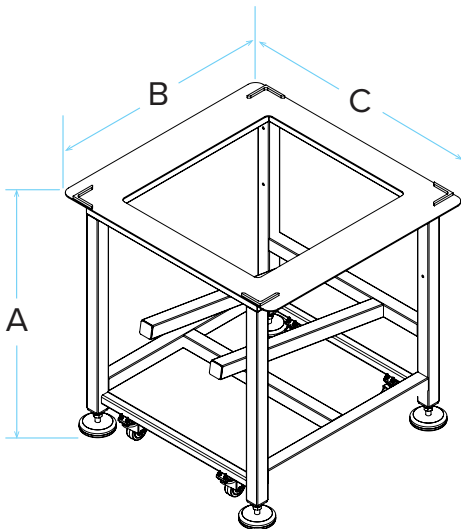

MULTI-PURPOSE
RETAIL SCALES

PRICE COMPUTING
SCALES

PRICE COMPUTING
PRINTING SCALES

LABELERS

WRAPPING
SYSTEMS

SOFTWARE

ACCESSORIES

POWER
CONDITIONING

RETAIL
LABELS

WARRANTY