

LaserLight3™

ConnexLink™ Wireless Radio Installation

Rice Lake Weighing Systems® is a registered trademark of Rice Lake Weighing Systems. All other brand or product names within this publication are trademarks or registered trademarks of their respective companies.

The ConnexLink Wireless Radio kit (PN 212753) allows communication from a LaserLight3 to a device with the matching radio (such as an indicator or remote display).



Manuals and additional resources are available from the Rice Lake Weighing Systems website at www.ricelake.com
Warranty information can be found on the website at www.ricelake.com/warranties



NOTE: For more information about LaserLight3, see *LaserLight3 Large Display Indicator Technical Manual (PN 213589)* or *LaserLight3 Remote Display Technical Manual (PN 214748)*.
ConnexLink documentation and resources can be found at www.lairdconnect.com.



CAUTION: The LaserLight3 does not have a power switch. Before working with the unit, ensure the power cord is disconnected from the power outlet.

Parts List





Item	Part No.	Description	Qty
	129662	RF Pair Transceivers	1
	N/A	Antenna (Included with 129662)	1
	166240	Antenna Extension Cable	1
	215203	ConnexLink Transceiver to Display Cable	1
	214713	LaserLight3 ConnexLink Power Cable	1
	225477	3/8 Snap-In Adhesive Back	4

Table 1. ConnexLink Wireless Radio Kit Parts List

Installation

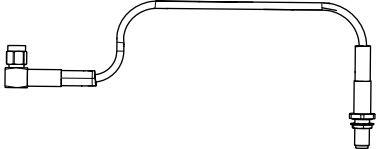
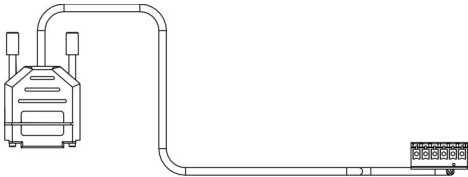

IMPORTANT: Each ConnexLink radio is marked as Client or Server. Install the server type in indicators and the client type in remote displays.

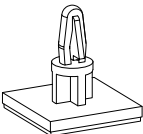
Communication Type

LaserLight3 Type or Operating Mode	ConnexLink Type in LaserLight3	Paired ConnexLink
LaserLight3 Indicator	Server	Client
LaserLight3 Remote Display	Client	Server

Figure 1. ConnexLink Type Information

- To attach adhesive feet to ConnexLink, align adhesive standoffs with ConnexLink mounting holes then push to snap into place.

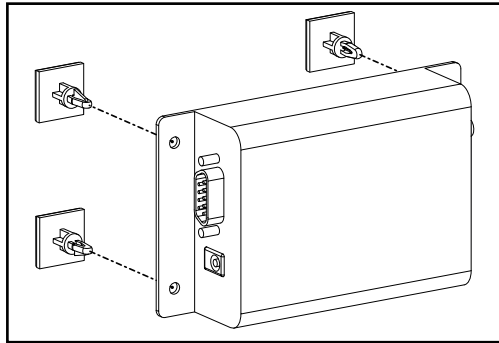

Figure 2. Align and Attach Adhesive Standoffs to ConnexLink

- Disconnect LaserLight3 power cable from power outlet.
- Open the LaserLight3 enclosure.



IMPORTANT: The ConnexLink power cable has a black (negative) wire and a black with white segments (positive) wire. Ensure power cables wires are connected to the power supply terminals with the same polarity.

- Attach the black negative power wire's spade to the free -V0 terminal on LaserLight3 power supply.
- Attach the black and white positive power wire's spade to the free +V0 terminal on LaserLight3 power supply.

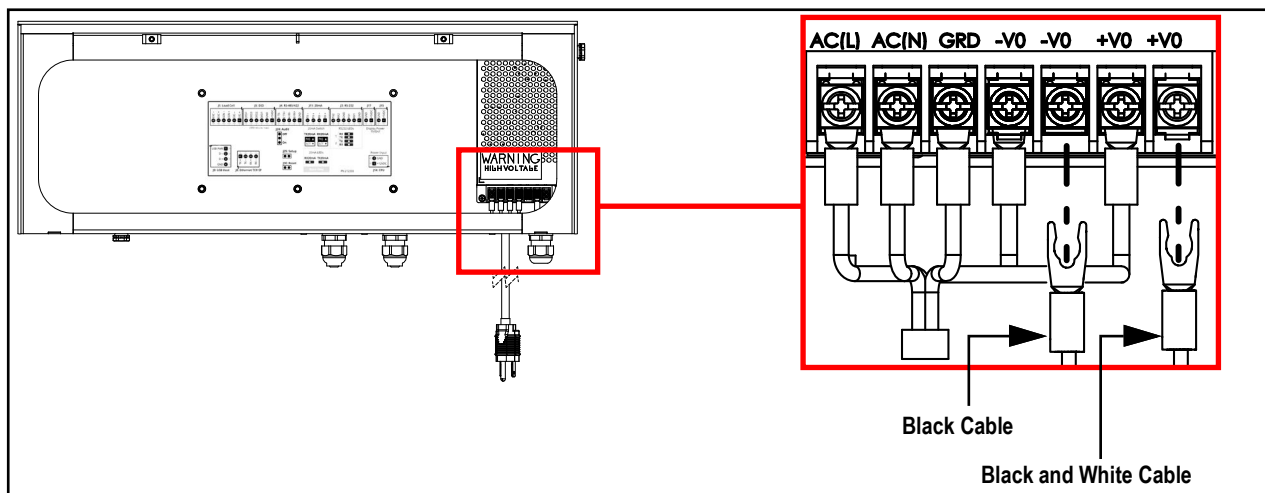

Figure 3. Connect Power Cable Spade Connectors to LaserLight3 Power Supply

- Attach the power supply cable barrel connector to the ConnexLink 7-18VDC jack.

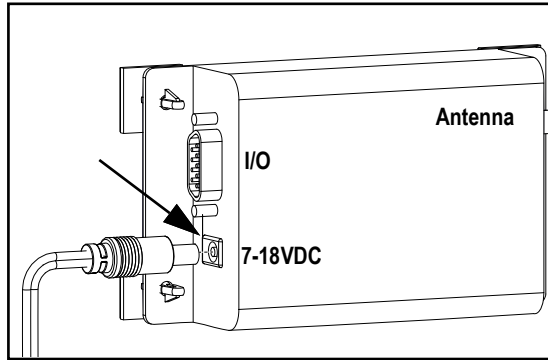

Figure 4. Connect Power Cable to ConnexLink 7-18VDC Jack

- Unscrew the antenna hole screw plug (bottom of enclosure) then collect the nut and washer (inside enclosure).

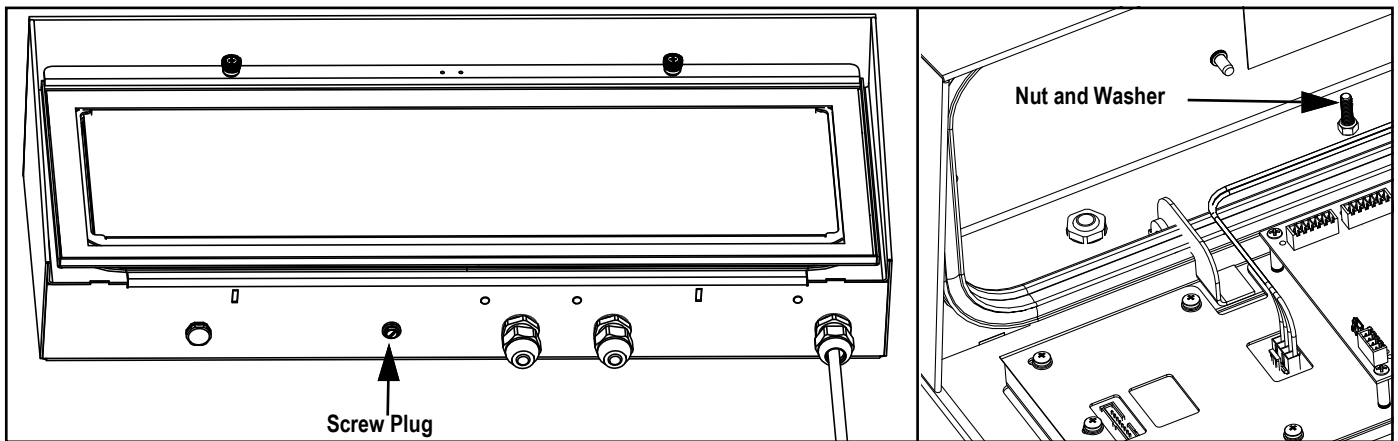

Figure 5. Remove Antenna Hole Plug Hardware

- Remove nut and tooth washer from antenna extension cable.

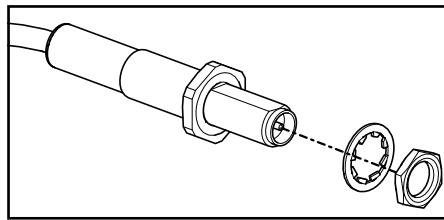

Figure 6. Remove Retaining Hardware from Antenna Extension Cable

- Inside enclosure, insert threaded end of antenna extension cable into antenna hole.

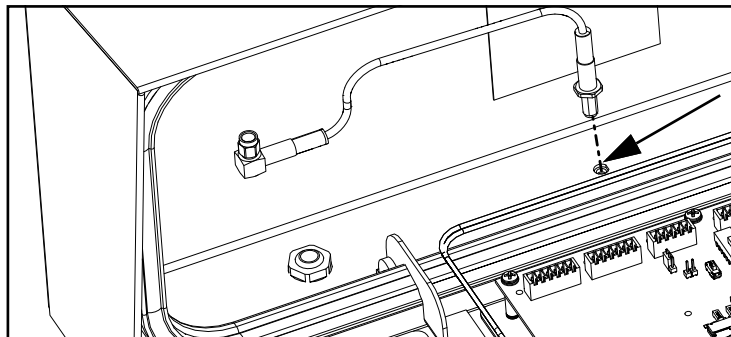

Figure 7. Insert Antenna Cable in Mounting Hole

10. Install washer and nut (previously removed) on threaded end of extension cable protruding from bottom of enclosure.
11. Turn antenna clockwise onto the antenna extension cable until tight.

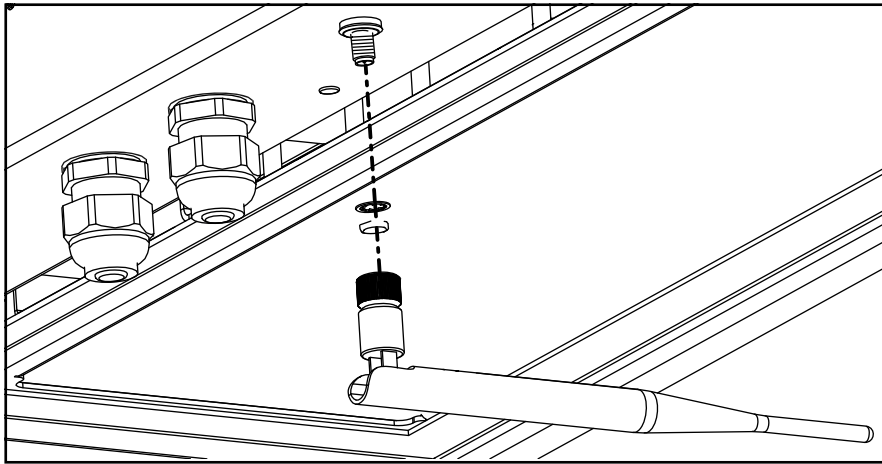

Figure 8. Install Antenna and Retaining Hardware

12. Turn the free end of the antenna extension cable clockwise onto the antenna jack on ConnexLink until tight.

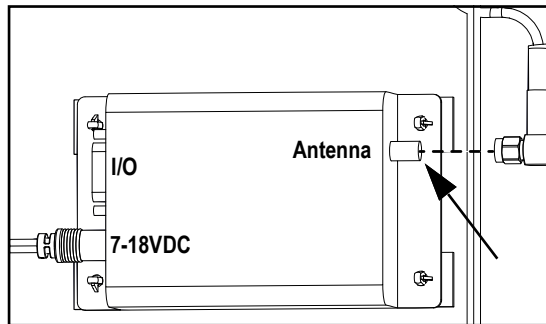

Figure 9. Attach Antenna Extension Cable to ConnexLink

13. Attach transceiver 6-pin connector to RS-232 port (J3) on LaserLight3 CPU board.

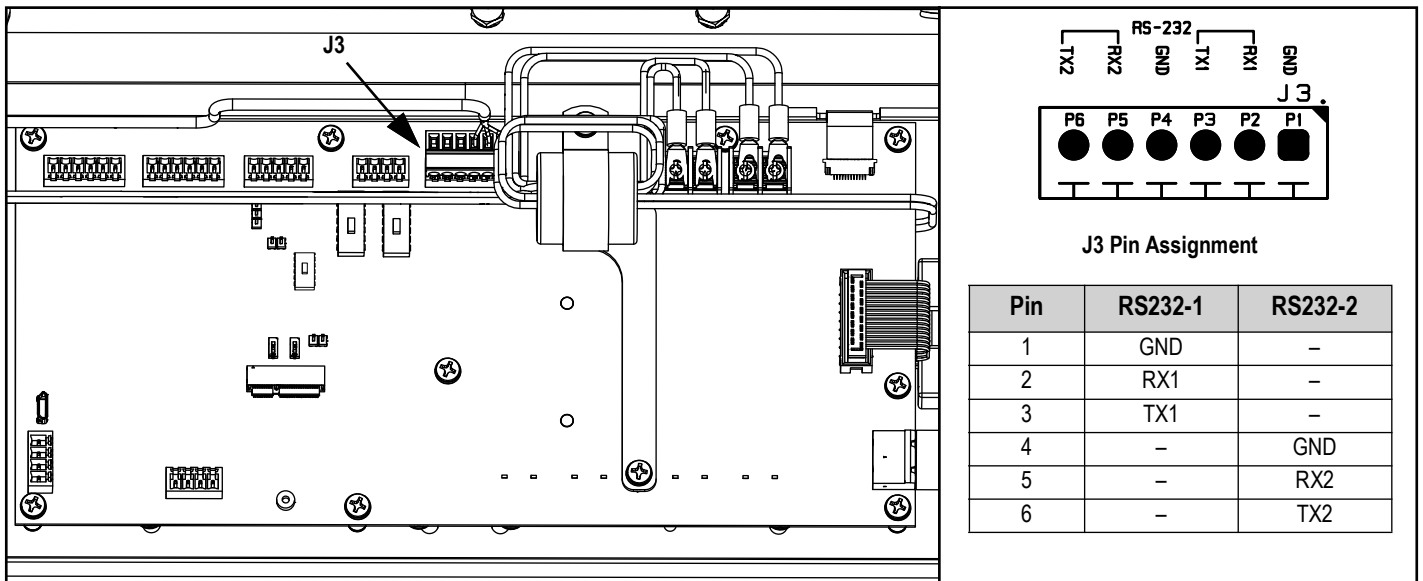

Figure 10. Attach Transceiver 6-Pin Connector to RS-232 Port

14. Attach the transceiver cable 9-pin connector to the ConnexLink I/O port and finger tighten retaining screws.

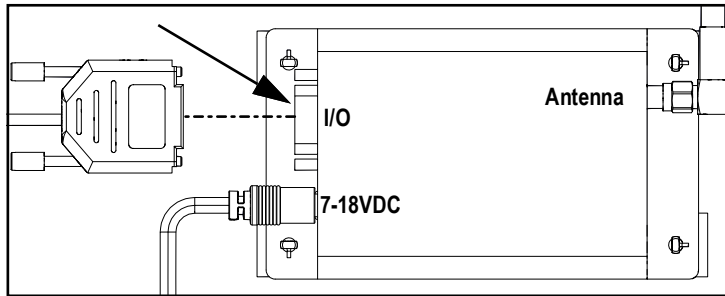

Figure 11. Connect Transceiver Cable 9-Pin Connector to ConnexLink

15. Clean mount surface with Isopropyl Alcohol, and let dry.
 16. Peel protective backing off adhesive standoffs and position ConnexLink with power jack at top (vertically) in left side of LaserLight3 enclosure.



IMPORTANT: Ensure ConnexLink position will not obstruct enclosure door operation or make contact with circuit boards.

17. Apply firm pressure to adhesive pads for 30 seconds.

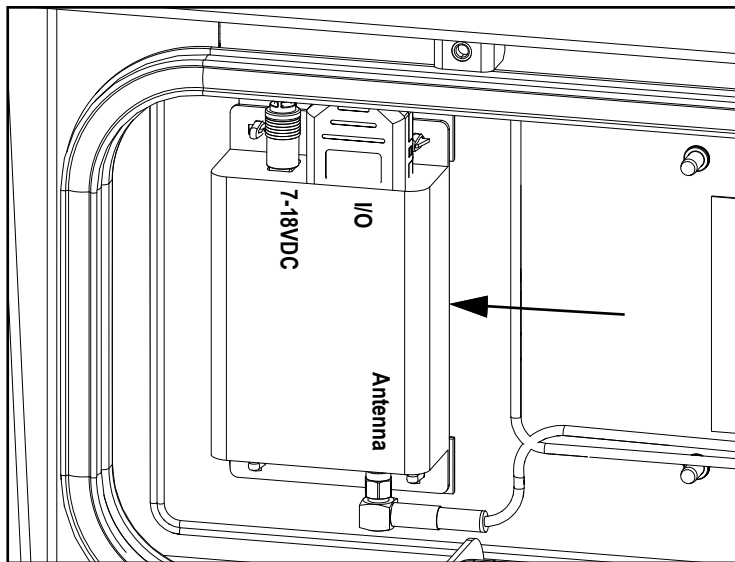

Figure 12. Attach ConnexLink with Adhesive Standoffs to Enclosure

Serial Configuration

After hardware installation, LaserLight3 software must be configured to communicate from its RS-232 port with the ConnexLink. In order to function correctly, the Baud and Bits parameters in the LaserLight3 require setup.

NOTE: By default LaserLight3 is configured with the required parameters to operate the ConnexLink. Ensure that the following settings are configured. If LaserLight3 default serial communication configuration has been altered, the system will not function. For more information about LaserLight3, see LaserLight3 Large-Display Weight Indicator Technical Manual (PN 213589) or LaserLight3 Remote Display Technical Manual (PN 214748).

LaserLight3 Large-Display Weight indicator Serial Menu

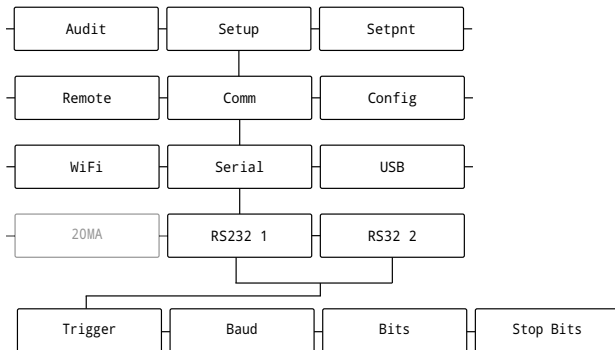

LaserLight3 Remote Display Serial Menu

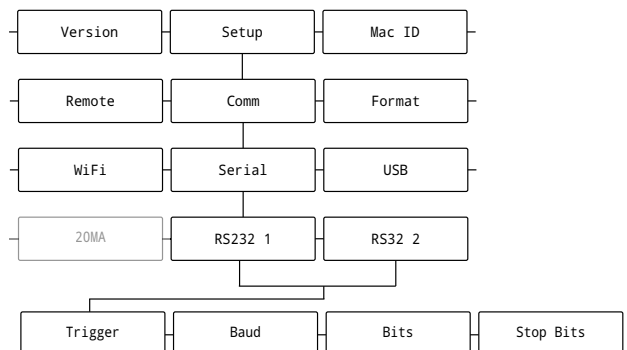



Figure 13. Baud/Bits Parameter Menu Path

1. Enable Setup mode by either pressing the  key (if a shunt is installed on J24 pins two and three) or opening the LaserLight3 and shorting J25 pins momentarily.

NOTE: Enabling Setup mode grants access to various LaserLight3 menus that are restricted in normal operation, including the Setup menu.

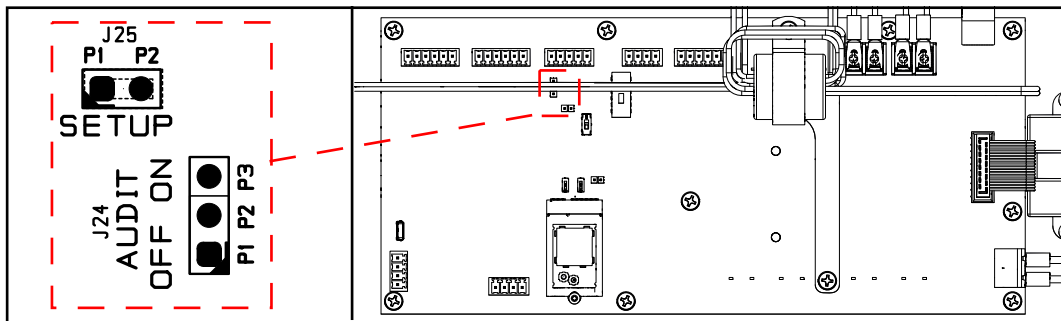















Figure 14. J24 Audit Jumper and J25 Setup Jumper

2. Perform one of the following:
 - For LaserLight3 Remote Display, navigate to **Setup ▼ Comm ▼ Serial ▼ RS232 1/2 ▼ Trigger ► Baud**
 - For LaserLight3 Large-Display Weight Indicator, navigate to **Audit ► Setup ▼ Comm ▼ Serial ▼ RS232 1/2 ▼ Trigger ► Baud**
3. Press . The configured Baud parameter setting displays.
4. Press  or  repeatedly until **9600** is selected.
5. Press . The Bits parameter displays.
6. Press . The configured Bits parameter setting displays.
7. Press  or  repeatedly until **8None** is selected.
8. Press . The Stop Bits parameter displays.

9. Press . The configured Stop Bits parameter setting displays.
10. Press  or  repeatedly until 1 is selected.
11. Press .
12. Press  to exit the menu.

Specifications

This kit features a ConnexLink communication module. Visit www.lairdconnect.com to view the latest list of technical specifications on the communication module.

Frequency Band

- 902-928 MHz

Modulation

- FHSS FSK

Interface

- Standard: RS-232 (DB9 Male)
- ConnexLink Pro: RS-485 (6-Pin Terminal Block)

Serial Interface Data Rate

- Up to 115200 kbps

Output Power

- 5 mW-1000 mW variable

Input Power

- 7-18 VDC

Current Draw (at 12 VDC)

- 400 mA TXD, 40 mA RXD

Channels

- 32 selectable channels

Security

- 1-byte system ID, DES

Sensitivity

- -99dB at full RF data rate

Range (line-of-sight):

- Up to 20 miles (32 km)

Temperature:

- -40°F to 176°F (-40°C to 80°C)

Humidity (non-condensing):

- 10% to 90%

Weight:

- <6 oz (<170 g)

Dimensions:

- 4.75 x 2.75 x 1.17 in (121 x 70 x 30 mm)

Antenna Connector:

- Reverse polarity SMA jack (female)



© Rice Lake Weighing Systems Content subject to change without notice.

230 W. Coleman St. • Rice Lake, WI 54868 • USA
U.S. 800-472-6703 • Canada/Mexico 800-321-6703 • International 715-234-9171 • Europe +31 (0)26 472 1319