

MAS-LM

Stationary Mechanical Animal Scale

Installation Manual



© Rice Lake Weighing Systems. All rights reserved.

Rice Lake Weighing Systems® is a registered trademark of
Rice Lake Weighing Systems.

All other brand or product names within this publication are trademarks or
registered trademarks of their respective companies.

All information contained within this publication is, to the best of our knowledge, complete and
accurate at the time of publication. Rice Lake Weighing Systems reserves the right to make
changes to the technology, features, specifications and design of the equipment without notice.

The most current version of this publication, software, firmware and all other product
updates can be found on our website:

www.ricelake.com

Revision History

This section tracks and describes manual revisions for awareness of major updates.

Revision	Date	Description
D	April 15, 2026	Established revision history

Table i. Revision Letter History



Technical training seminars are available through Rice Lake Weighing Systems. Course descriptions and dates can be viewed at www.ricelake.com/training or obtained by calling 715-234-9171 and asking for the training department.

Contents

1.0	Introduction	5
1.1	Safety Decals	6
1.2	Overview	7
1.3	Lifting and Unloading	7
1.3.1	Slinging the Scale	7
1.3.2	Lifting Instructions	8
1.3.3	Package Removal	8
2.0	Installation	9
2.1	Permanent Installation	9
2.1.1	Install	9
2.1.2	Assemble and Install the Load Cell Assembly Housing	12
3.0	Replacement Parts	14
4.0	Maintenance	20
4.1	Maintenance Schedule	20
4.2	Scale Maintenance Procedures	20
4.3	Replace Flooring	20
4.4	Pipe Lever Repair	20
4.5	Check Bolt	21
4.6	Troubleshooting	21
5.0	Specifications	22



Rice Lake continually offers web-based video training on a growing selection of product-related topics at no cost. Visit www.ricelake.com/webinars

1.0 Introduction

The Stationary Mechanical Animal Scale (MAS-LM) is manufactured with top quality components and is engineered using the latest technology to provide operating features and reliability unmatched for years to come.

Please take the time to read this manual completely through before attempting to install the system. Although the MAS-LM has been designed for easy setup and use, a thorough understanding of this manual will ensure that the user will receive the maximum benefit from the system.



Manuals are available from Rice Lake Weighing Systems at www.ricelake.com/manuals

Warranty information is available at www.ricelake.com/warranties

Safety Definitions:



DANGER: Indicates an imminently hazardous situation that, if not avoided, will result in death or serious injury. Includes hazards that are exposed when guards are removed.



WARNING: Indicates a potentially hazardous situation that, if not avoided, could result in serious injury or death. Includes hazards that are exposed when guards are removed.



CAUTION: Indicates a potentially hazardous situation that, if not avoided, could result in minor or moderate injury.



IMPORTANT: Indicates information about procedures that, if not observed, could result in damage to equipment or corruption to and loss of data.

General Safety



Do not operate or work on this equipment unless this manual has been read and all instructions are understood. Failure to follow the instructions or heed the warnings could result in injury or death. Contact any Rice Lake Weighing Systems dealer for replacement manuals.



WARNING

Failure to heed could result in serious injury or death.

Do not allow minors (children) or inexperienced persons to operate this unit.

Do not operate without all shields and guards in place.

Do not use for purposes other than weighing.

Do not place fingers into slots or possible pinch points.

Do not place hands, feet or any body part underneath the scale at any time. The scale could be lowered at any time, crushing body parts.

Do not use any load bearing component that is worn beyond 5% of the original dimension.

Do not make alterations or modifications to the unit.

Do not remove or obscure warning labels.

Keep hands, feet and loose clothing away from moving parts.

Be sure the gates are latched or tied inward before transporting the scale.

Animal safety is a very serious issue and must be observed when handling any type of animal.

The scale surface may become slippery during use; a build-up of manure on the scale may reduce traction. It is recommended that you take any necessary precautions to maintain an acceptable level of animal footing.

Do not calibrate this scale with a weight cart having a gross weight in excess of 25% of the total capacity of the scale. This device is designed to be calibrated with single block weights spread evenly throughout the floor of the scale. If using a test cart, use 3/4 in plywood for testing and calibration. This will minimize the damage of the x-lug flooring. Shift tests should not be done with more than 4,000 lb or 1,815 kg in a 4 x 4 ft area. Failure to comply with this warning will result in damage to the scale and void the warranty.

1.1 Safety Decals

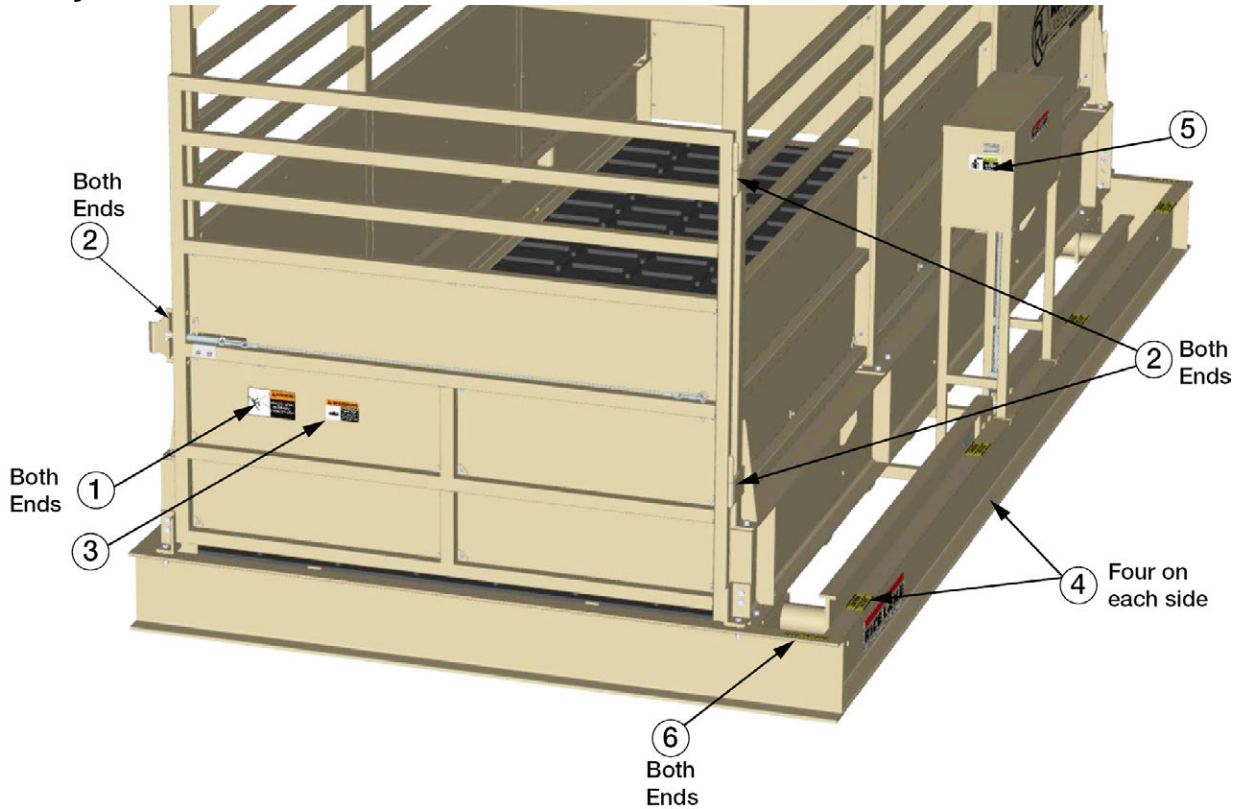

Figure 1-1. Safety Decal Locations

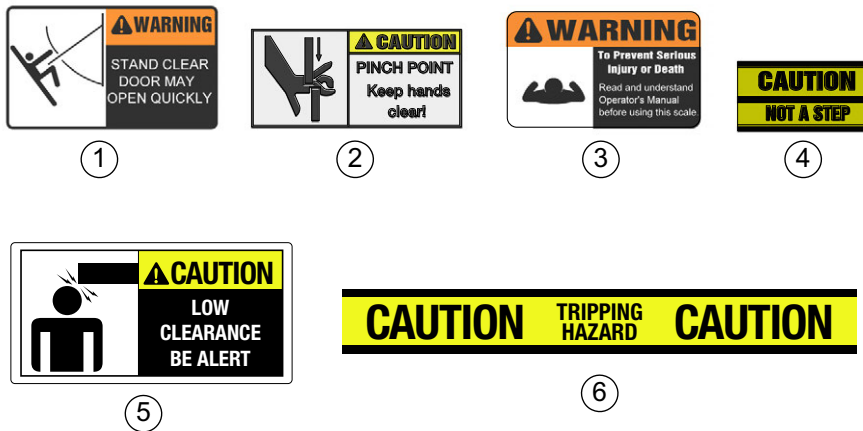

Figure 1-2. Safety Decals

No	PN	Description	Qty
1	151902	Warning, Opens Quickly	2
2	151909	Caution, Pinch Point	6
3	151908	Read Manual	1
4	151901	Caution, Not A Step	8
5	151904	Caution, Low Clearance	2
6	151897	Caution, Tripping Hazard	2

Table 1-1. Safety Decal Descriptions

1.2 Overview

The MAS-LM animal scale, shown in Figure 1-3, consists of a sheeted animal cage suspended by a pipe lever system on top of a stationary base frame. When transporting, the scale system is locked down using overload bolts, protecting the lever system from damage during transport. A digital indicator and S-Beam can be connected to the scale to display the weight.

The MAS-LM animal scale can be used on any firm surface that is straight, plumb and level.



NOTE: Legal for Trade applications often require a concrete slab foundation. Check with local Weights and Measure officials.



Figure 1-3. Rice Lake Stationary Livestock Scale

1.3 Lifting and Unloading



DANGER: The unit is very heavy. Ensure that adequate straps are used for lifting the scale and that straps are in the proper location. See Table 1-2 for strap lengths.

Ensure no one is under the scale when lifting and moving to the location selected.

1.3.1 Slings the Scale

MAS-LM animal scales can be slung with four equal length straps connected from the lifting lugs to a single point in the center.

Model	Min Strap Length (ft)
13 x 9	8
15 x 9	9
17 x 9	9.5
19 x 9	10.5

Table 1-2. Minimum Strap Length Required for Lifting

1.3.2 Lifting Instructions

Lift the scale using the lifting lugs (see Figure 1-4), four straps and a crane or loader. See Table 1-2 for required strap lengths.

1. Lift the scale using adequate lifting straps and device.
2. Place on a prepared location; a firm surface that is straight, plumb and level. Store scale on the same type of surface.

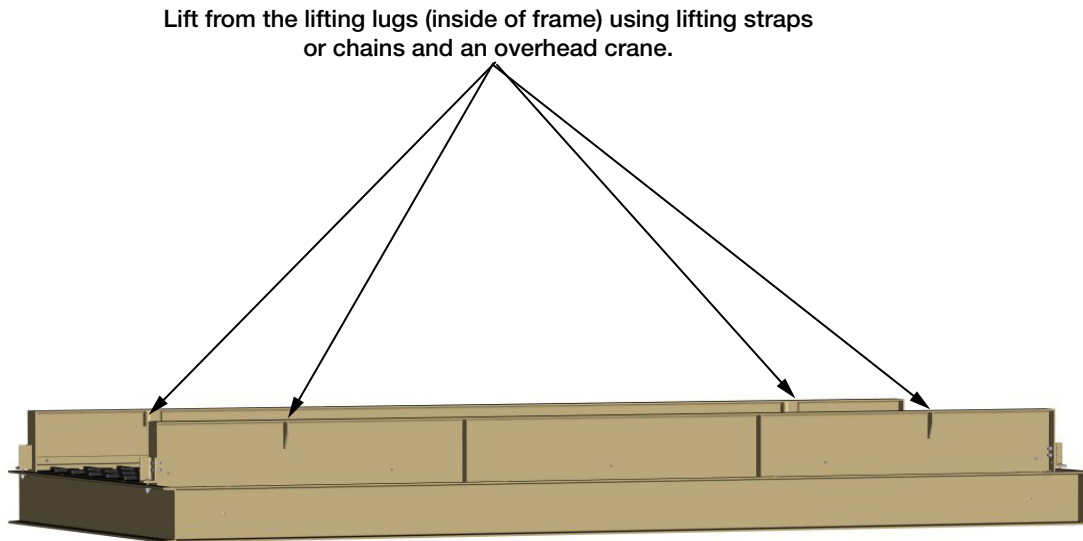

Figure 1-4. Lift Points



DANGER: The unit is very heavy. Ensure that adequate straps are used for lifting the scale and that straps are in the proper location. See Table 1-2 for required strap lengths.

Ensure no one is under the scale when lifting and moving to the location selected.

1.3.3 Package Removal

The weighcenter is boxed and shipped on a separate skid with the scale. Be careful when removing the packaging to avoid damaging the weighcenter.



NOTE: Please recycle the packaging material.

Place the parts safely in a location where they will not be damaged.

2.0 Installation

2.1 Permanent Installation

Assembly of the MAS-LM at its permanent location is recommended. As with any weighing equipment, the accuracy of the scale is dependent on the installation. In all installations, the scale must be level to ensure proper operation.

Rice Lake Weighing Systems recommends a concrete foundation (piles or piers) for permanent installations. The foundation must be able to support the gross weight of the scale (scale dead weight plus scale capacity), and the piles or piers must be situated directly under the pipe lever fulcrum stands.



NOTE: Shim under the fulcrum stand if required to ensure the scale is straight, plumb and level.

The foundation must not be subject to distortion or motion due to frost action. A qualified local professional should be consulted to recommend the proper size foundation for the location. Foundation dimensional requirements are available from the dealer or Rice Lake Weighing Systems. Requirements may vary from one Weights and Measures jurisdiction to another, please contact the local office.

2.1.1 Install

1. Place base frame on a firm surface that is straight, plumb and level.

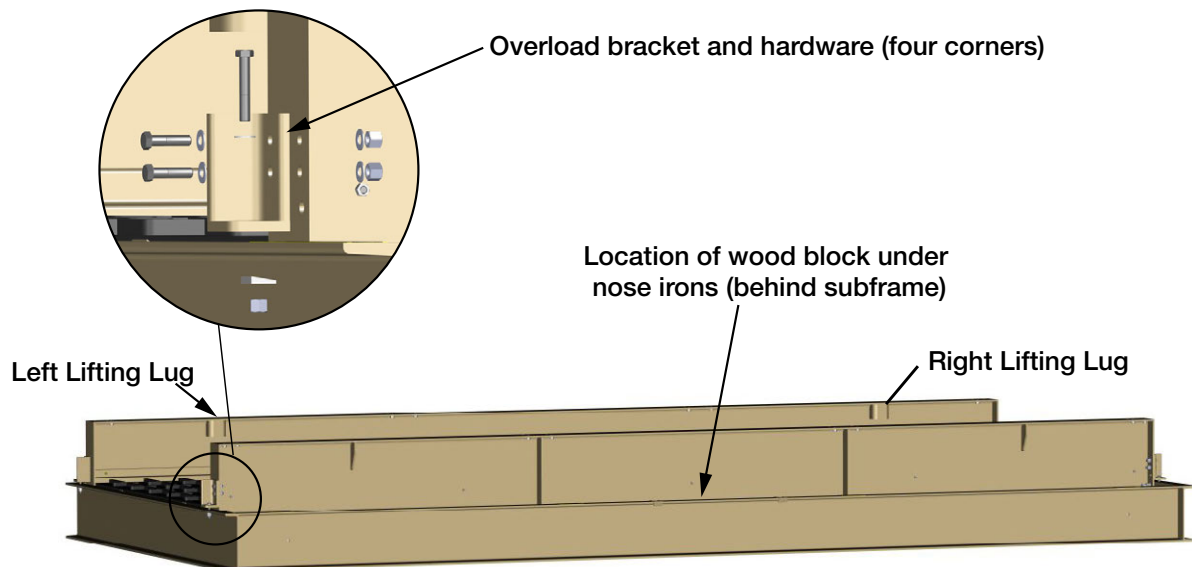

Figure 2-1. Overload Bolts and Wood Block Removal



DANGER: The unit is very heavy. Ensure that adequate straps are used for lifting the scale and that straps are in the proper location. See Table 1-1 for required strap lengths.

Ensure no one is near the scale when lifting and moving into the location selected.

2. Remove four (one set at each corner) overload bolts and brackets.
3. Attach lifting straps to the lift lugs inside the frame and using a crane or similar lifting device, lift the floor slightly.
4. Cut bands securing wood block under the nose irons of the pipe lever assembly and remove the wood block.



NOTE: Concrete drawings available upon request.

Retain overload bolts, brackets and wooden block in case the scale would need to be moved in the future.

5. Install the two internal upright assemblies and the two gate upright assemblies to the base frame using the hardware provided. See Figure 2-2.



IMPORTANT: Do not tighten hardware at this time, it will need to be loose to allow for wall panel installation.

Upright and wall installation should be done with two people or an overhead crane.

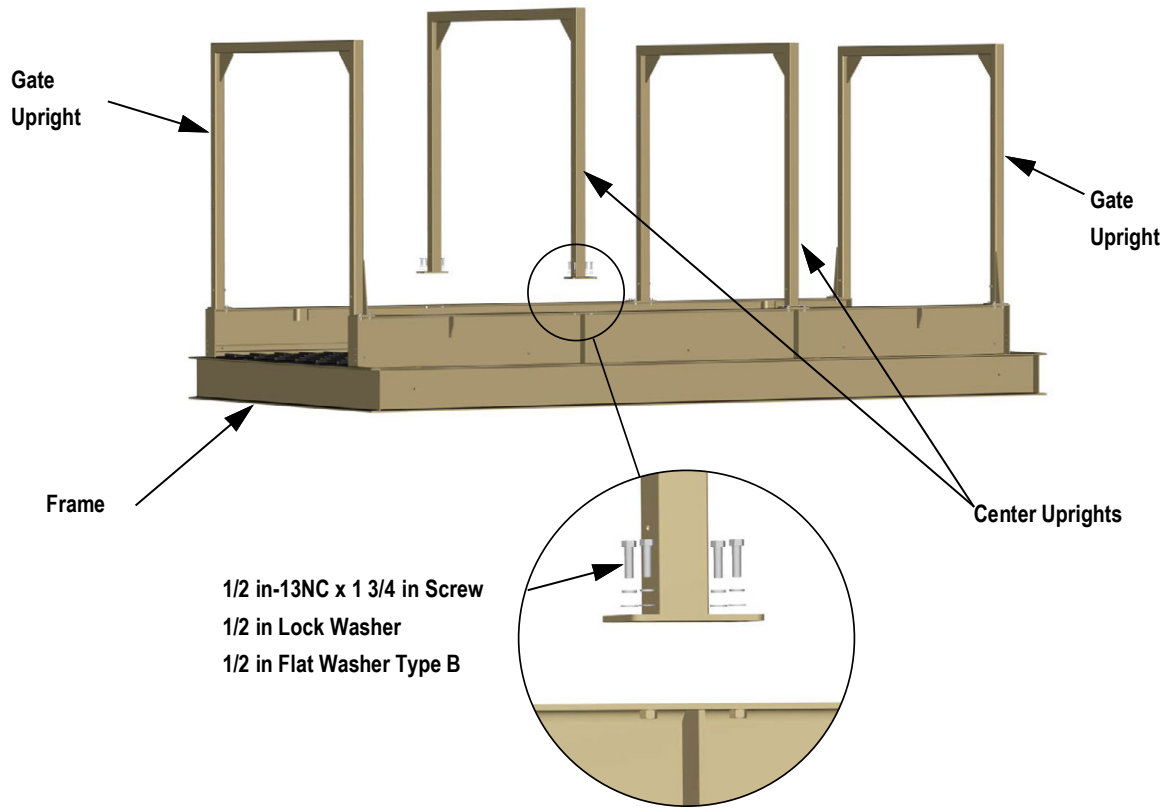

Figure 2-2. Install Internal Overhead Assemblies

6. Align holes in wall panels with holes in uprights and secure in place with provided hardware.
7. Tighten hardware for the wall panels, then tighten hardware securing the uprights to the frame.



IMPORTANT: At center uprights, hardware will go through two wall panels (one on each side of the upright).

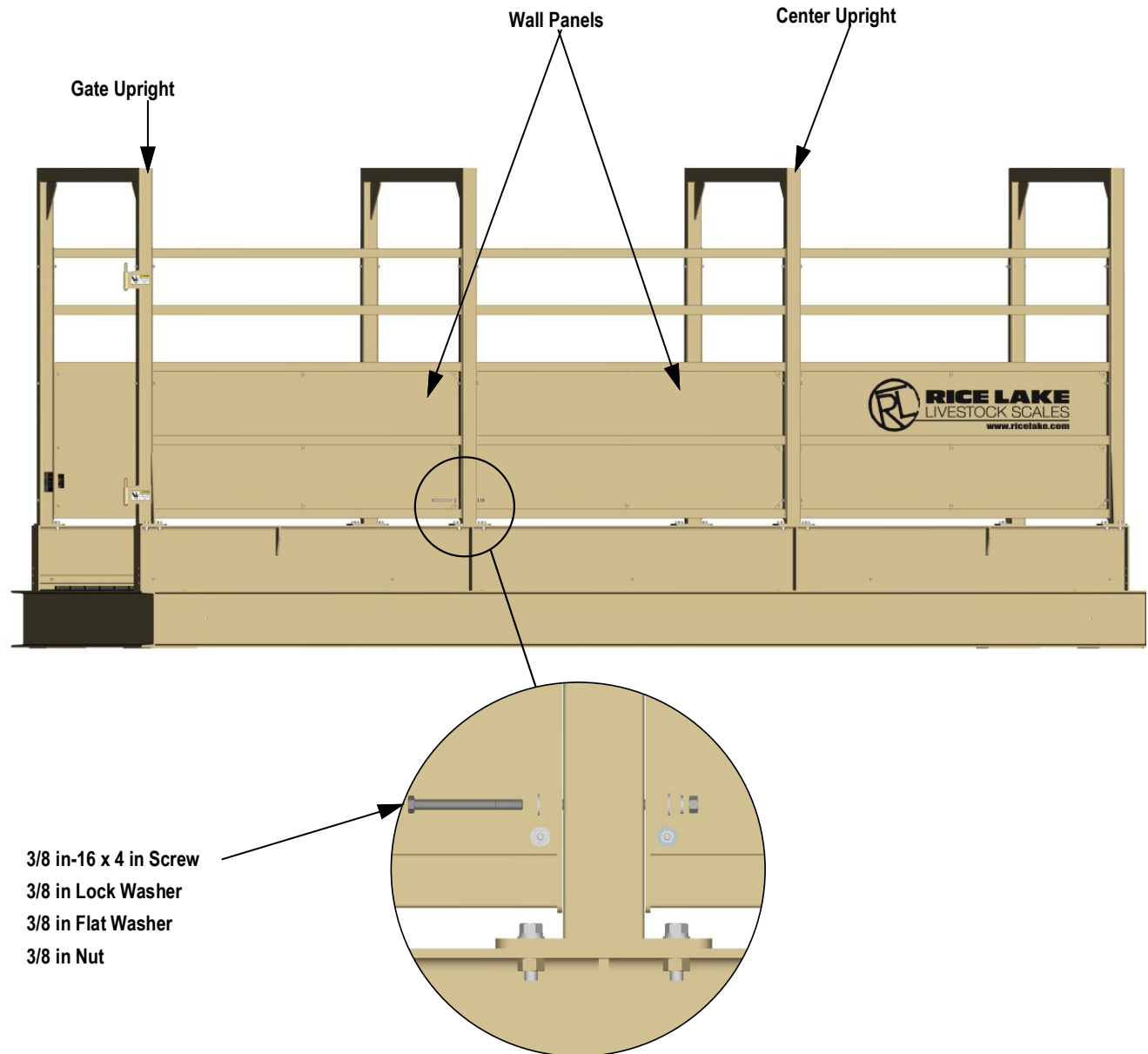

Figure 2-3. Install Wall Panels

8. Align top hinge section on gate with lower hinge section on upright and lower gate onto the bottom hinge section.



IMPORTANT: The latch should line up with the strike plate welded to the end upright. If it doesn't line up, washers are supplied to adjust the gate. Remove gate from hinges and place washers on the upright hinge, then reinstall the gate. Use washers as needed to align the latch to the striker plate.

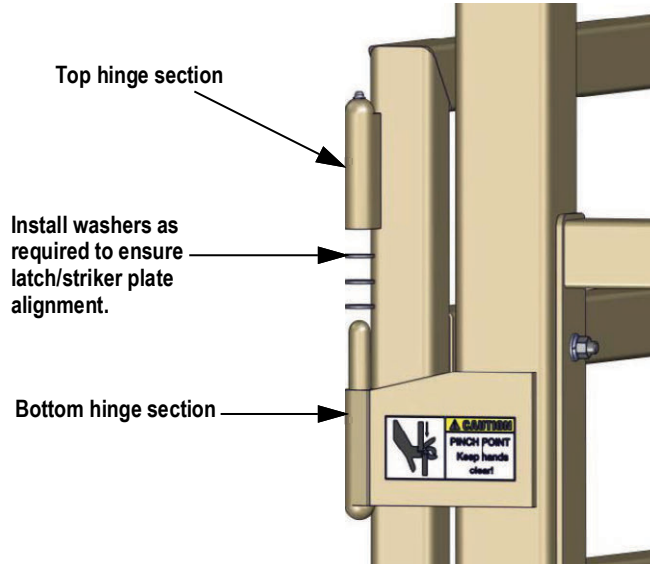

Figure 2-4. Gate Installation and Alignment

2.1.2 Assemble and Install the Load Cell Assembly Housing



NOTE: Install the Load Cell Assembly Housing on the left side (j-box side) of the scale.

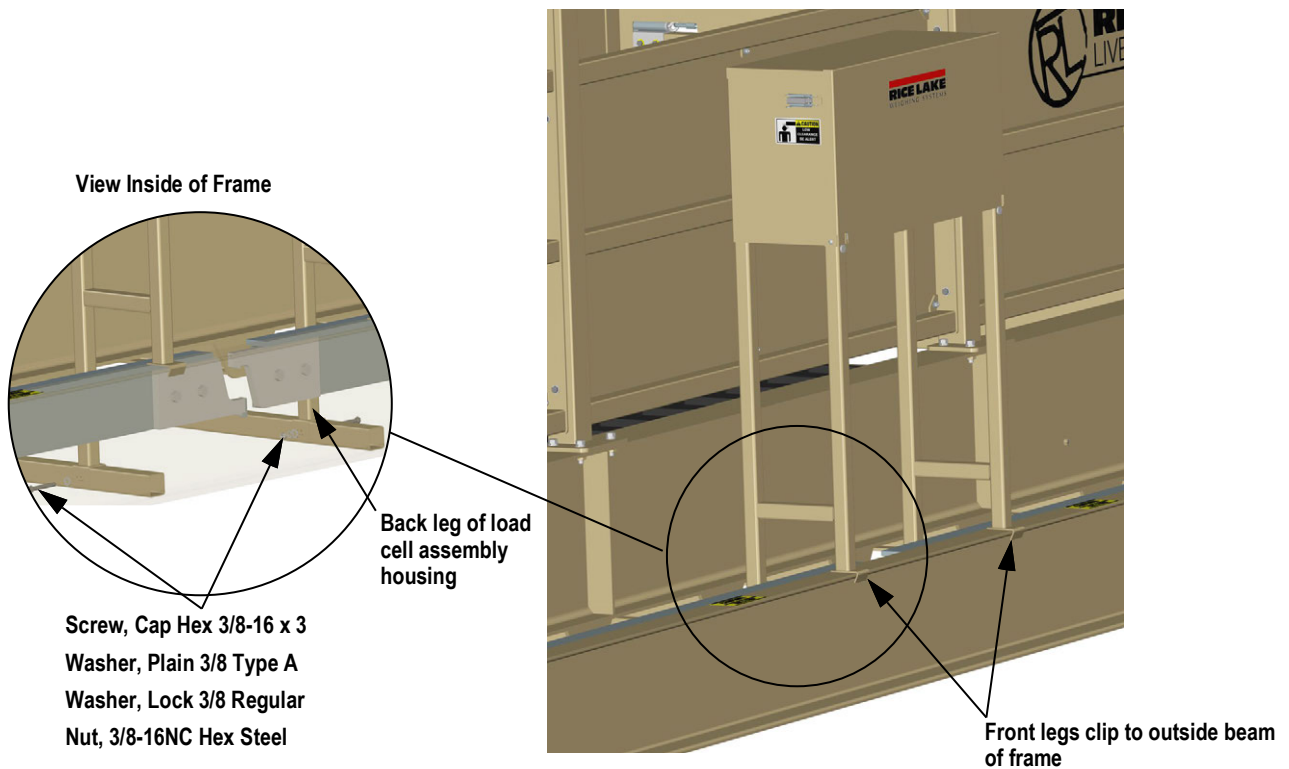

Figure 2-5. Load Cell Assembly Housing Installation

1. Set the load cell assembly housing on the frame in the location shown.
 - The two front legs will secure to front of frame as shown.
 - The back legs will sit on top of the inside frame member as shown.
2. Secure back legs to frame with bolts, washers and nuts.

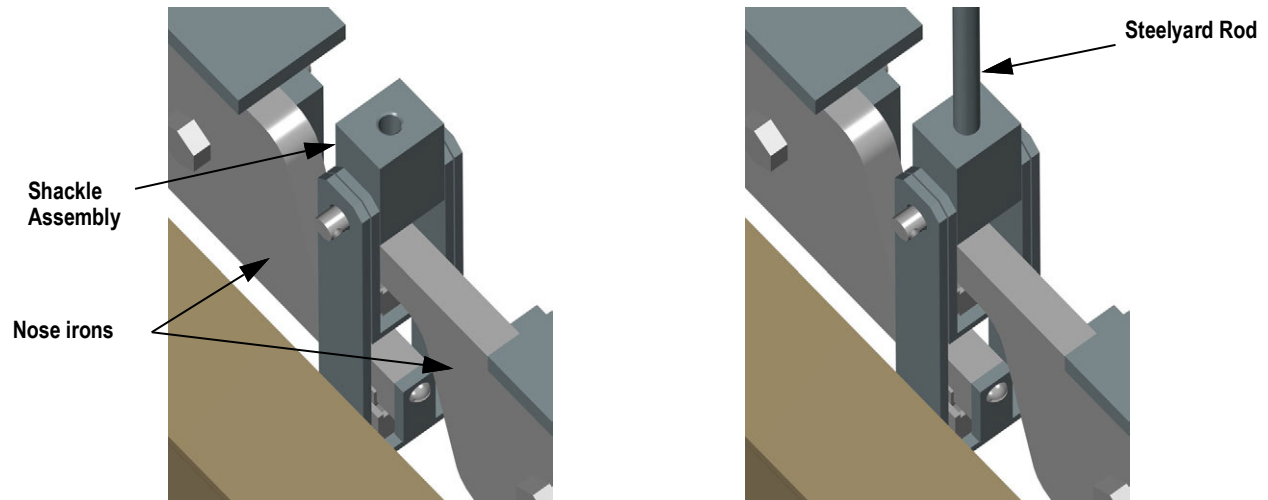

Figure 2-6. Assembly Shackle

3. Place the shackle assembly between the nose irons of the pipe lever assembly.
4. Place the long threaded steelyard rod through the hole in the bottom of the load cell assembly housing.
5. Screw the steelyard rod into the shackle assembly.

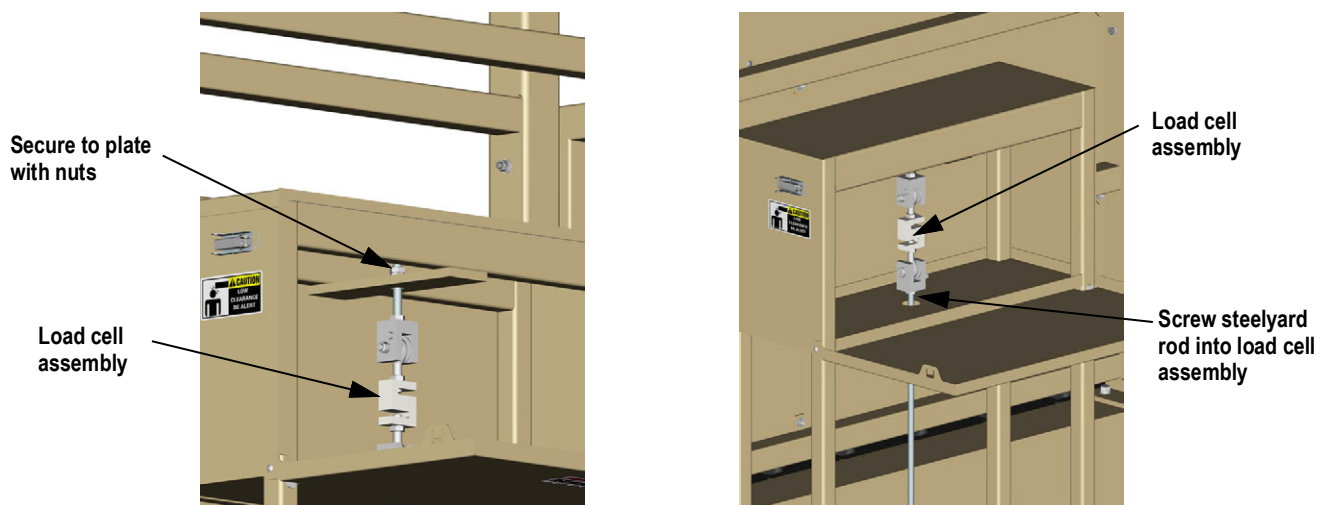

Figure 2-7. Load Cell Assembly

6. Open the cover of the load cell assembly housing and place the load cell assembly inside, secure to plate with nuts.
7. Screw the threaded steelyard rod into the bottom of the load cell assembly.
8. The load cell can be wired into the indicator.
9. Level the pipe lever arms by turning the threaded rod.
10. The scale can now be calibrated by a certified service provider.



NOTE: To remove the load cell assembly housing reverse the above steps.

3.0 Replacement Parts

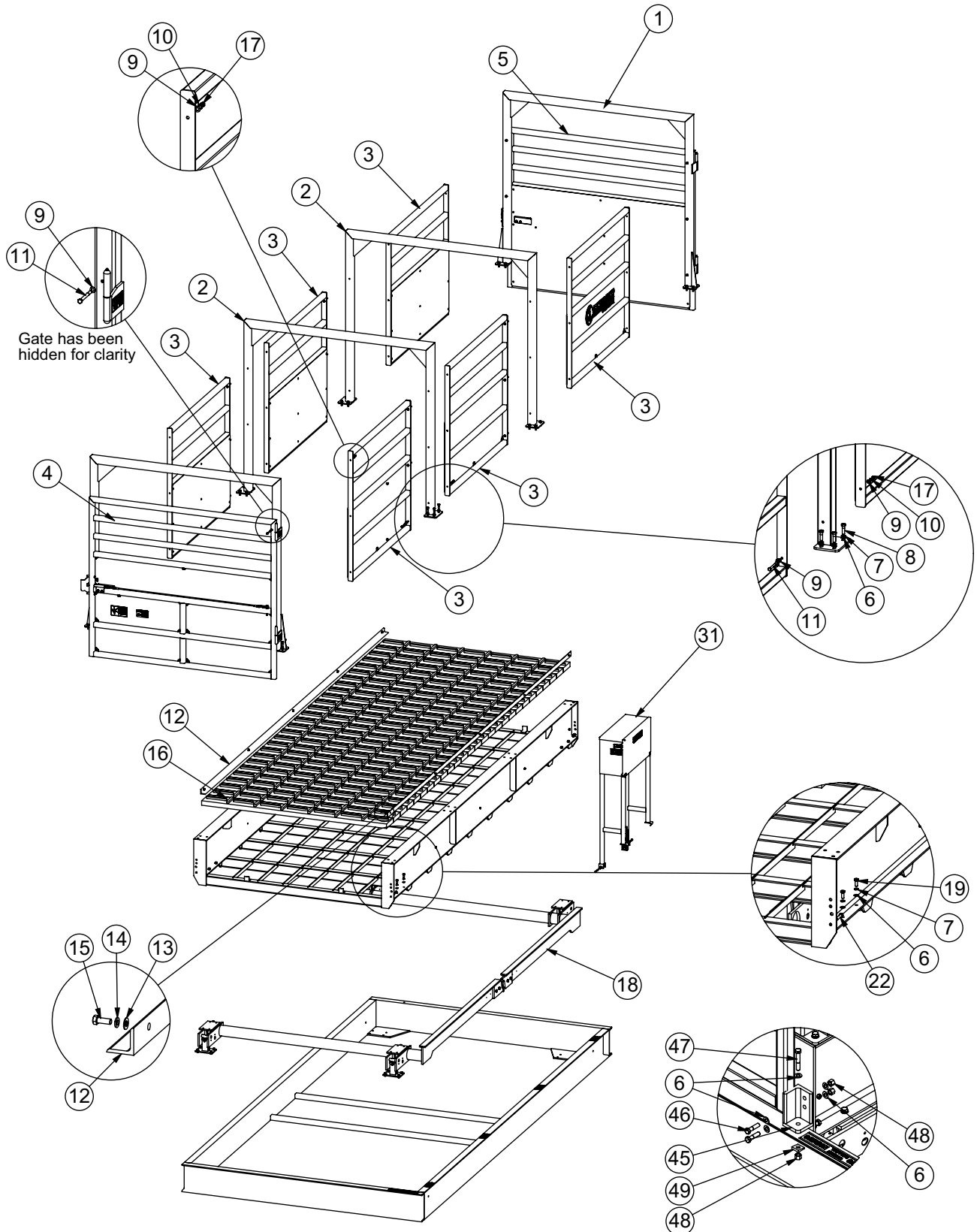

No	PN	Description
1	151192	End Overhead, 7 ft LC/LM
	154680	End Overhead, 10 ft LC/LM
2	151169	Internal Overhead, 7 ft
	154678	Internal Overhead, 10 ft
3	151174	Wall Segment 18 x 2197 LC AG
4	151190	Gate Assembly, LH 7 ft (Includes Item #1)
	154682	Gate Assembly, LH 10 ft (Includes Item #1) See Figure 3-2 for Gate Parts
5	151194	Gate Assembly, RH 7 ft (Includes Item #1)
	154681	Gate Assembly, RH 10 ft (Includes Item #1) See Figure 3-2 for Gate Parts
6	15173	Washer, Plain 1/2 in Type B
7	15167	Washer, Lock 1/2 in Regular
8	114014	Screw, Cap 1/2-13NC x 1-3/4 in
9	21938	Washer, Plain 3/8 in Type A
10	15159	Washer, Lock 3/8 in Regular
11	127003	Screw, Hex Cap 3/8-16
12	155750	Angle, X-Lug hold-down (13 ft)
	154140	Angle, X-Lug hold-down (14 ft)
	155820	Angle, X-Lug hold-down (17 ft)
	151296	Angle, X-Lug hold-down (18 ft)
	154117	Angle, X-Lug hold-down (20 ft)
13	111737	Washer, Plain 3/8 in Type A
14	111736	Washer, Lock 3/8 in Regular
15	151352	Bolt, 3/8-16NC x 1 in Hex
16	151307	Flooring, X-Lug Rough (9 ft)
	154676	Flooring, X-Lug Rough (11.5 ft)
17	132684	Nut, Hex 3/8-16NC GR5 Zinc
18		Pipe Lever Assembly (see Figure 3-3)
19	15054	Screw, Cap 1/2-13NC x 1-1/4 in
22	15080	Screw, Cap 1/2-13NC x 2-1/2 in
31	153249	Weighcenter (see Figure 3-4)
45	157754	R LM Frame Anchor
	157753	L LM Frame Anchor
46	157759	Screw, Cap 1/2-13NC x 2 in Hex
47	157762	Screw, Cap 1/2-13NC x 3 in Hex
48	157769	Nut, Lock 1/2-13NC Hex
49	106091	Washer, 1/2 in Square Beveled

Table 3-1. MAS-LC Scale Parts List

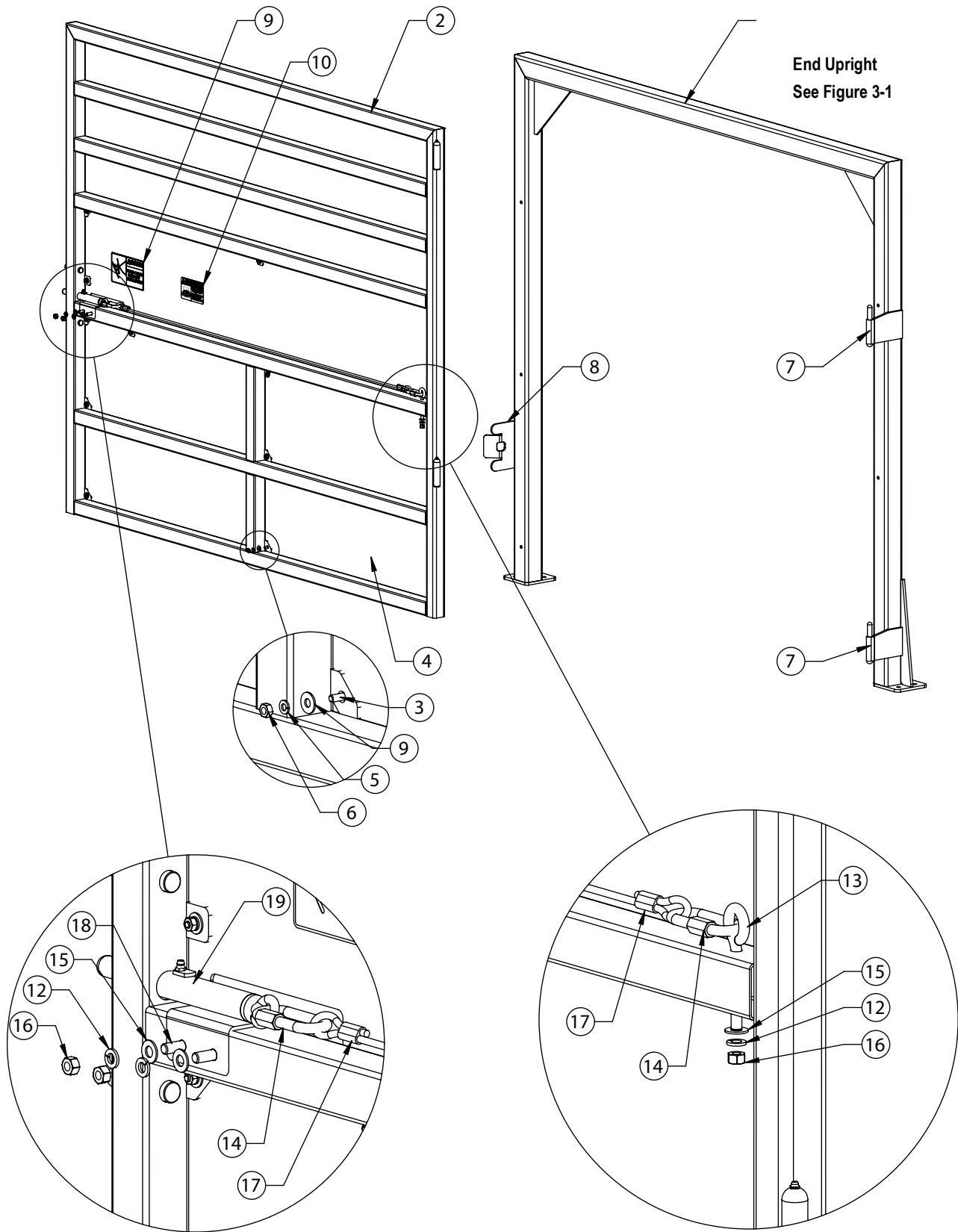

Figure 3-2. MAS-LM Parts Illustration – End Gates

No	PN	Description
1	164363	Bracket, Gate Lift Stop
2	151209	Washer, 0.0747 Thick
3	132917	Carriage Bolt, 1/4-20 x 1 in
4	159783	Kick Panel, LC and LM 7 ft
	164153	Kick Panel, LC and LM 9 ft
5	14641	Nut, 1/4-20NC HEX Steel
6	15147	Washer, Lock 1/4 in Regular
7	81427	Washer, Flat 1/4 in Steel
8	132684	Nut, Hex 3/8-16NC GR5 Z in
9	15159	Washer, Lock 3/8 in Regular
10	21938	Washer, Plain 3/8 in Type A
11	150715	Link, Quick 3/8 in
12	150820	Eye Bolt, 3/8-16NC x 3 in
13	151193	Panel, Gate, 7 ft, LC/LM
	154689	Panel, Gate, 9 ft, LC/LM
14	150716	Cable, Latch 1/4 in OD, 7 ft
	154690	Cable, Latch 1/4 in OD, 9 ft
15	127013	Screw, Cap Hex 3/8-16 x 3 in
16	141394	Latch, LS/LM AG Scale
	131702	Gate Latch Spring
	160302	Hairpin, 0.08 x 1 9/16
17	151191	Gate, LH No Panel 7 ft
	154687	Gate, LH No Panel 10 ft
	151195	Gate, RH No Panel 7 ft
	154686	Gate, RH No Panel 10 ft
18	151192	Overhead End, 7 ft
	154680	Overhead End, 10 ft

Table 3-2. MAS-LM Repair Parts List – End Gates

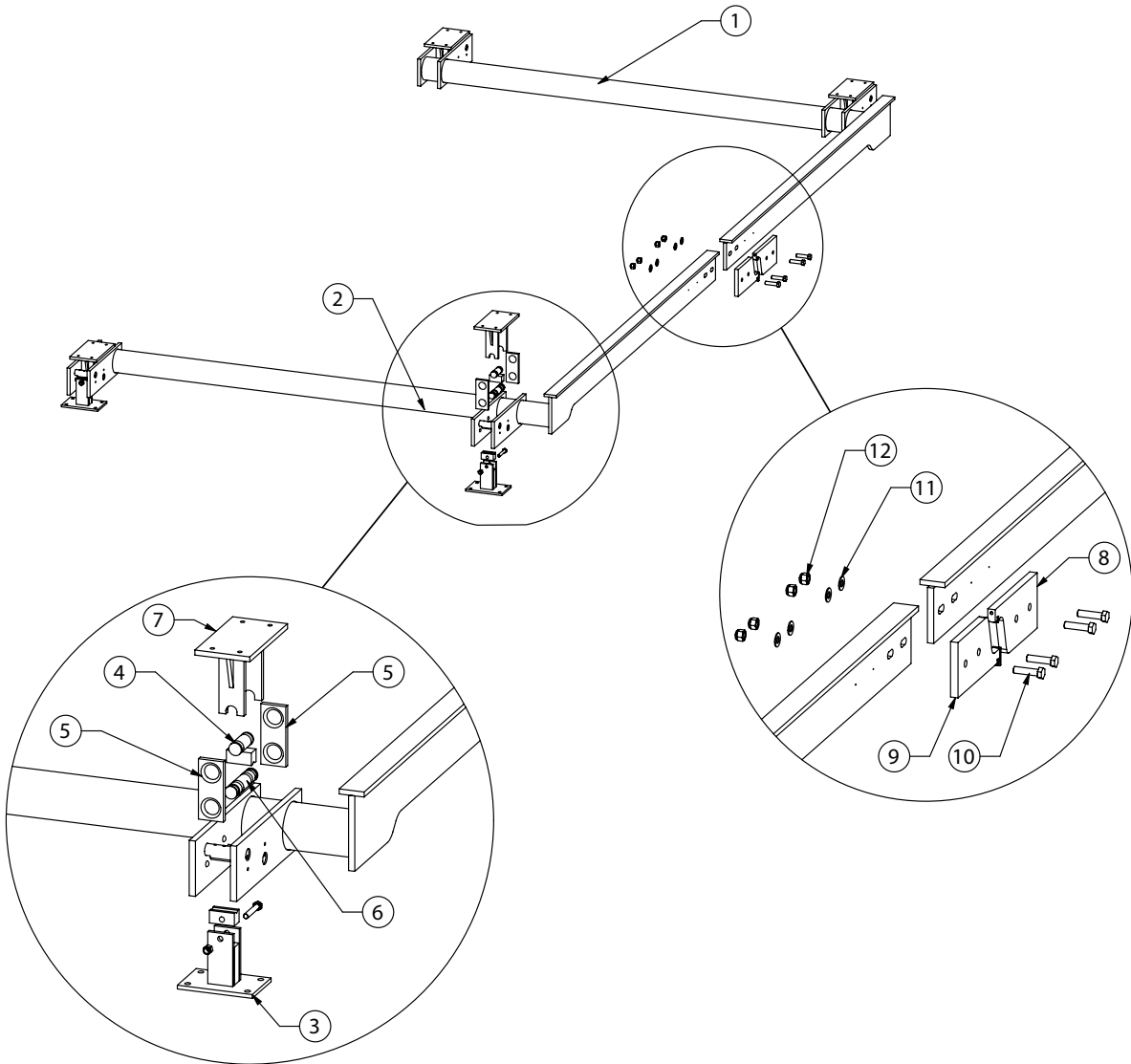

Figure 3-3. Pipe Lever Assembly Parts Illustration

No	PN	Description
1	152994	Main Lever WLDT, Right
2	152995	Main Lever WLDT, Left
3	153004	Fulcrum Stand Assembly, LM AG
4	153011	Bearing Saddle WLDT, LM
5	153015	Link, Suspension
6	153014	Pin, Trunion 1.25 in Dia
7	153000	Girder Chair WLDT, LM AG
8	39975	Right Nose Iron Assembly, 20k
9	39972	Left Nose Iron Assembly, 20k
10	26344	Screw, Cap 5/8-11NC x 2 1/2 in
11	15177	Washer, Plain 5/8 in Type A
12	40181	Nut, Lock 5/8-11NC HEX

Table 3-3. Pipe Lever Assembly Parts List

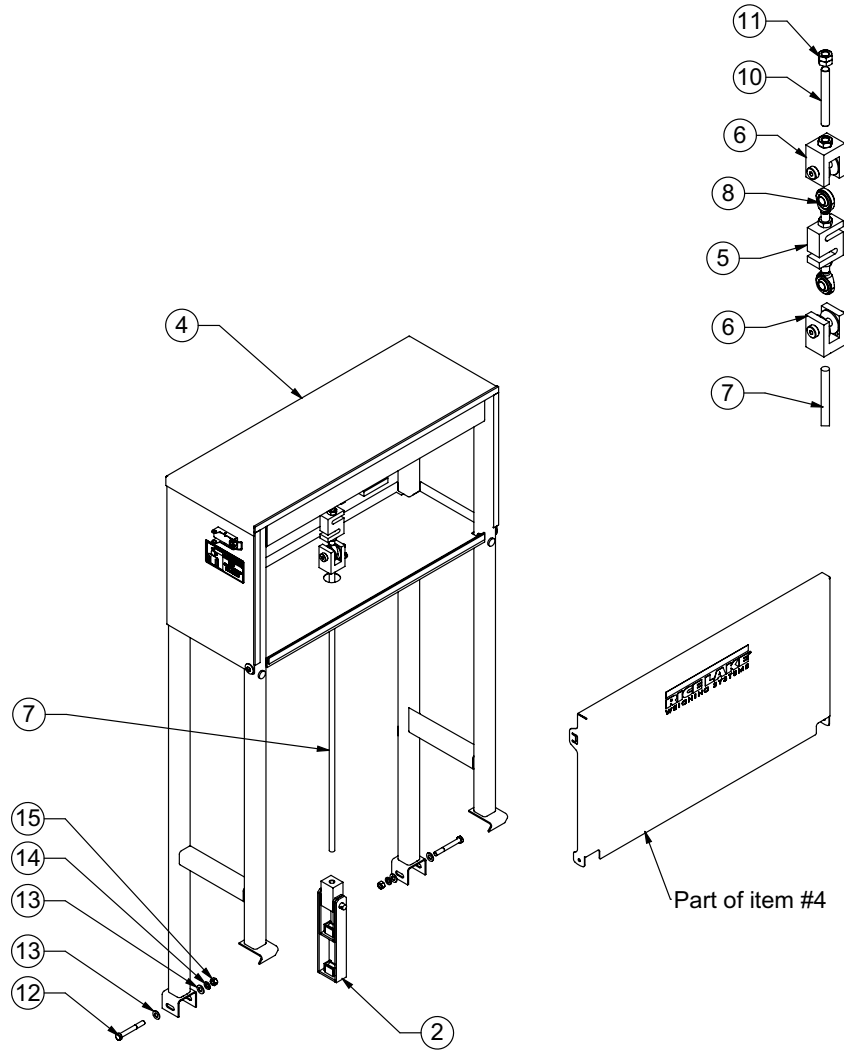

Figure 3-4. Weighcenter Assembly Parts

No	PN	Description
2	39969	Shackle ASSY, 20k
3	23113	Printer, Ticket TMU 295 (Optional)
4	153249	Enclosure ASSY, Weigh
5	21440	Load Cell, SBM RL20000B-2k
6	17787	Clevis ASSY, 1/2-13NC
7	153260	Steelyard Rod, 1/2 in Dia
8	17740	Rod End, 1/2-20NF 1-1/2 in
9	132919	IQ+ 590-AG Indicator (Optional)
10	153261	Rod, Threaded 1/2-13NC x 4 in
11	14664	Nut, Jam 1/2-20NF HEX
12	127013	Screw, Cap Hex 3/8-16 x 3 in
13	21938	Washer, Plain 3/8 in Type A
14	15159	Washer, Lock 3/8 in Regular
15	14656	Nut, 3/8-16NC HEX Steel

Table 3-4. Weigh Center Assembly Parts List



NOTE: If printer and indicator are purchased, cable (PN 15547) needs to be purchased as well.

4.0 Maintenance

4.1 Maintenance Schedule

Weekly

1. Check entire scale for buildup of debris. Remove any debris found on, under or around the scale.
2. Check for dirt and debris in the load cell stands and clean accordingly.
3. Check all external cables and conduit for damage.

Monthly

Grease hinges and latch assembly.

4.2 Scale Maintenance Procedures

Cleaning Load Cell Stands

It is very important to keep any excess debris from building up in the load cell stand. Lift scale, block it up and clean dirt out of the load cell stands through the drain holes located at the bottom of the stand.

4.3 Replace Flooring

1. Remove the hold down angle on both sides of the floor by loosening the bolts.
2. Remove section(s) of flooring that are to be replaced.
3. Install new flooring.
4. Reinstall the hold-down angles.

4.4 Pipe Lever Repair



DANGER: The unit is very heavy. Ensure that adequate straps are used for lifting the scale and that straps are in the proper location. See Table 1-1 for strap lengths.

Ensure no one is near the scale when lifting and moving into the location selected.

1. Remove the weighcenter, see Section 2.1.2 on page 8.
2. Attach lifting straps to the lift pockets inside the frame.
3. Using a crane or similar lifting device, lift the floor slightly.

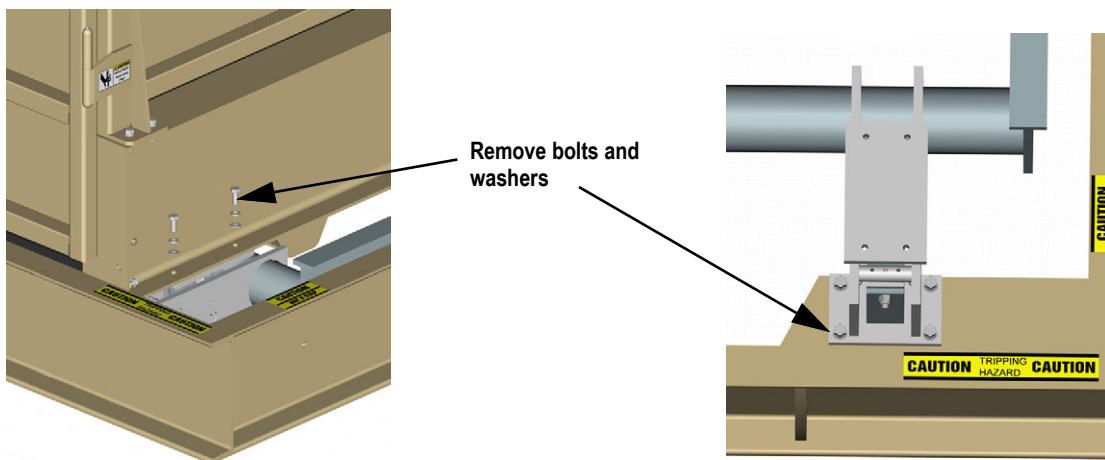

Figure 4-1. Pipe Lever Repair

4. Remove four bolts and washers at each corner, two are located inside the scale under the flooring.
5. Remove four bolts with washers securing the fulcrum to the bottom plate of the frame.
6. To install, reverse the above steps.



NOTE: The corner assemblies will need to be held in place when installing, tape can be used. Remove after assembly is complete.

4.5 Check Bolt

There is a check bolt at each corner of the scale. After installation or repairs, ensure that the bolt is screwed in so that 3/8 in of threads extrude beyond the frame. Tighten jam nuts to secure the bolt.

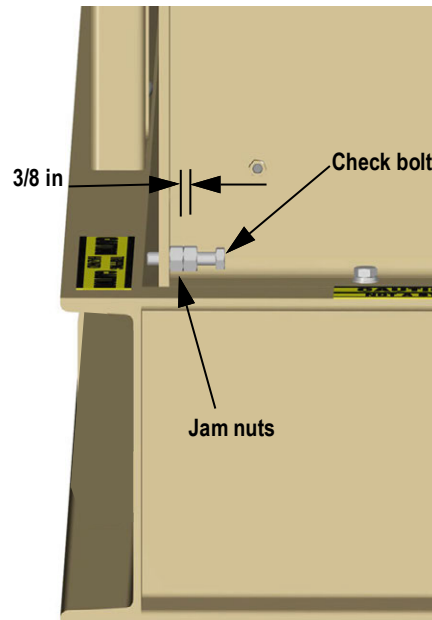

Figure 4-2. Check Bolt

4.6 Troubleshooting

Symptom	Probable Cause	Action
The weight reading on the indicator is unstable.	The circuit board in the control panel may be wet or the load cell may have moisture in it.	Dry any areas that are contaminated with moisture. Check for leaks and reseal.
	A load cell cable may be pinched or damaged.	Contact RLWS or a qualified dealer for support. Cutting the load cell cable will void the warranty. Special repair techniques are required.
The scale has a positive error when loading or a negative error when unloading.	Mechanical binding problem on scale.	Check for debris around or under the scale. Check each load cell location for foreign material. Check all items that run from on the scale to off the scale. Check all gates or gathering panels for contact.
Scale will not ZERO.	Weight on scale larger than the allowable ZERO window.	Clean the scale deck of debris, then Zero the scale.
		Zero Window parameter set incorrectly.



NOTE: If a problem with the scale is suspected, contact Rice Lake Weighing Systems or a qualified local scale dealer.

5.0 Specifications

Full Scale Capacity:

20,000 lb, 5 lb increments

Racks and Gates:

Constructed of three-inch steel main tubes;
two-inch steel support tubes
Two end swing gates with latch (gates swing
outward from scale)

Load Cells:

Single tool steel S-beam

Warranty:

Two-year limited warranty on the weighbridge
Two-year parts and electronics warranty

Approvals:



NTEP

94-126

Measurement
Canada
Approved

Measurement Canada

AM-4847



© Rice Lake Weighing Systems Content subject to change without notice.

230 W. Coleman St. • Rice Lake, WI 54868 • USA USA: 800-472-6703 • International: +1-715-234-9171